

CAST IRON PRESSURE-FIRED WET BASE HOT WATER BOILERS



C.S.A. Certified
For Natural Gas Or Propane



Tested For 100 LBS.
ASME
Working Pressure



⚠ CAUTION ⚠

Do not use this vent pipe or fittings for venting incinerators of any kind.

⚠ WARNING ⚠

For correct installation of your venting system, read all of these instructions and refer to the vent pipe manufacturer's instructions.

Failure to use a proper venting system will void the manufacturer's warranty and may result in rapid deterioration of the venting system, a potential health hazard.

Faulty vent installation can allow toxic fumes to be released into living areas. This may cause serious bodily injury or property damage. Vent performance may also be affected by improper assembly.

Install separate vents for forced exhaust appliances and natural draft appliances. A common vent between natural draft and forced exhaust appliances may cause toxic gases to exhaust through the natural draft appliance rather than to the outside air. Breathing exhaust gases will cause serious personal injury or death.

⚠ WARNING ⚠

*All installations of boilers and venting should be done **ONLY** by a qualified expert and in accordance with the appropriate manual. Installing or venting a boiler or any other gas appliance with improper methods or materials may result in serious injury or death due to fire or asphyxiation from poisonous gases such as carbon monoxide which is odorless and invisible.*

VENTING INSTRUCTIONS

P/N# 240005665, Rev. 1.1 [05/06]

FRESH AIR FOR COMBUSTION - CHIMNEY VENTED BOILERS



Be sure to provide enough fresh air for combustion. Enough air ensures proper combustion and assures that no hazard will develop due to the lack of oxygen.

Ventilation of the boiler room must be adequate to provide sufficient air to properly support combustion per the latest revision of the National Fuel Gas Code, ANSI Z223.1, Section 5.3.

When a boiler is located in an unconfined space in a building or conventional construction frame, masonry or metal building, infiltration normally is adequate to provide air for combustion and ventilation. However, if the equipment is located in a building of unusually tight construction (See the National Fuel Gas Code, ANSI Z223.1, Section 1.7), the boiler area should be considered as a confined space. In this case air for combustion and ventilation shall be provided according to Part 5. If there is any doubt, install air supply provisions in accordance with the latest revision of the National Fuel Gas Code.

You must provide for enough fresh air to assure proper combustion. The fire in the boiler uses oxygen. It must have a continuous supply. The air in a house contains only enough oxygen to supply the burner for a short time. Outside air must enter the house to replace that used by the burner. Study following two examples to determine your fresh air requirements.

BOILER IN UNCONFINED SPACE

If your boiler is in an open area (unpartitioned basement) in a conventional house, the air that leaks through the cracks around doors and windows will usually be adequate to provide air for combustion. The doors should not fit tightly. Do not caulk the cracks around the windows.

An unconfined space is defined as a space whose volume is not less than 50 cubic feet per 1,000 Btu per hour of the total input rating of all appliances installed in the space.

BOILER IN CONFINED SPACE

ALL AIR FROM INSIDE BUILDING: The confined space shall be provided with two permanent openings communicating directly with an additional room(s) of sufficient volume so that the combined volume of all spaces meets the criteria for an unconfined space. The total input of all combustion equipment installed in the combined space shall be considered in making this determination. Each opening shall have a minimum free area of one square inch per 1,000 Btu per hour of the total input rating of all combustion equipment in the confined space but not less than 100 square inches. One opening shall be within 12 inches of the top and one within 12 inches of the bottom of the enclosure. See **Figure #1**.

FIG. 1 – AIR OPENINGS FOR CLOSET OR UTILITY ROOM INSTALLATIONS

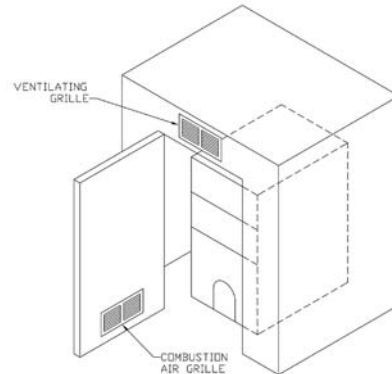

Example: Your boiler is rated at 100,000 Btu per hour. The water heater is rated at 30,000 Btu per hour. The total is 130,000 Btu per hour. You need two grilles, each with 130 square inches of FREE opening. Metal grilles have about 60% FREE area. To find the louvered area needed, multiply the FREE area required by 1.7 ($130 \times 1.7 = 221.0$ sq. in. louvered area). In this example, two grilles, each having an 8" x 30" (240 sq. in.) louvered area would be used. Figure 1 shows the grille locations.

ALL AIR FROM OUTDOORS: The confined space shall be provided with two permanent openings, one commencing within 12 inches of the top and one commencing within 12 inches of the bottom of the enclosure. The openings shall communicate directly,

or by ducts, with the outdoors or spaces (crawl or attic) that freely communicate with the outdoors.

1. When communicating with the outdoors directly or through vertical ducts, each opening shall have a minimum free area of one square inch per 4,000 Btu per hour of total input rating of all equipment in the enclosure.

NOTE: If you use a fireplace or a kitchen or bathroom exhaust fan, you should install an outside air intake. These devices will rob the boiler and water heater of combustion air.

2. When communicating with the outdoors through horizontal ducts, each opening shall have a minimum free area of one square inch per 2,000 Btu per hour of total input rating of all equipment in the enclosure.

3. When ducts are used, they shall be of the same cross-sectional area as the free area of the openings to which they connect. The minimum dimension of rectangular air ducts shall be not less than three inches.

FRESH AIR DUCT CAPACITIES

The following table shows fresh air duct capacities (in Btu) for ducts supplying fresh air to boilers in tightly

constructed houses (based on openings covered by 1/4" mesh screen, wood louvers, or metal louvers):

Fresh Air Duct Size	Duct Covering		
	1/4" Mesh Screen	Wood Louver	Metal Louver
3 1/2" x 12"	144,000	36,000	108,000
8" x 8"	256,000	64,000	192,000
8" x 12"	384,000	96,000	288,000
8" x 16"	512,000	128,000	384,000

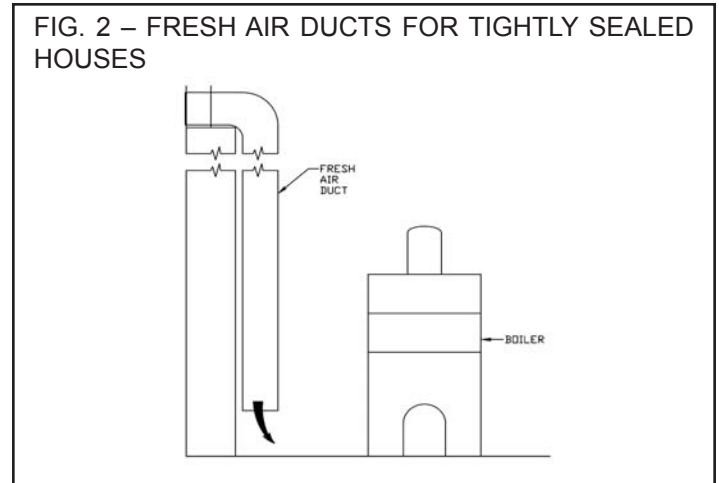

FLUE CONNECTIONS

APPLICABLE FEDERAL CODES

NFPA 54/ANSI Z223.1, National Fuel Gas Code (Part 7) and NFPA/ANSI211, Chimneys, Fireplaces, Vents, and Solid Fuel Burning Appliances. These codes contain information on special gas vents for Category II, III and IV appliances, vent sizing, location, air space clearances to combustibles and safe installation practices. The gas vent installer should be familiar with these Federal Codes as well as Local Codes and Regulations.

GENERAL INFORMATION - GAS VENTS & APPLIANCES

By federal codes, gas appliances are categorized by the pressure and temperature of the flue gas vented from the appliance. Category I and II appliances are natural draft (draft hood) vented, with high flue gas temperatures (Category I) and low flue gas temperatures (Category II). Category III and IV appliances are fan forced vents with high temperature (Category III) and low temperature (Category IV) flue gasses. Appliance efficiency is directly related to flue gas temperature. Higher efficiency appliances remove more heat from the gas, so they will have lower temperature flue

products. When flue gas temperatures are lowered, corrosive condensates may form in Category II, III, IV appliance vents, so special, corrosive resistant venting systems are required for higher efficiency appliances.

⚠ WARNING ⚠

Vents for Category I appliances may not be suitable for use with Category II, III, or IV appliances because condensate may corrode the vent.

Vents for Category III appliances may not be suitable for use with Category I appliances because flue gas temperatures may be too high.

Proper operation of the vent system and appliance is dependent upon the use of all parts specified by the manufacturer for use in the particular installation. Appliance and vent system performance may be affected by improper assembly.

See this manual for vent pipe installation and components.

IMPORTANT

For gas-fired boilers for connection to gas vents or chimneys, vent installations shall be in accordance with Part 7, "Venting of Equipment," of the *National Fuel Gas Code, ANSI Z223.1/NFPA-54*, or Section 7, "Venting Systems and Air Supply for Appliances," of the *CAN/CSA B149.1, Natural Gas and Propane Installation Code*, and applicable provisions of local building codes.

For oil-fired boilers for connections to vents or chimneys, vent installations shall be in accordance with applicable provisions of "Installation of Oil, Burning Equipment" *NFPA-31* – latest revision, and applicable provisions of local building codes.



Boiler is to be vented by natural draft and shall not be connected into any portion of a mechanical draft system operating under a positive pressure.

Inspect chimney to make certain it is constructed according to the latest revision of the NFPA211. Local codes may differ from this code and should be checked. Where there is a conflict, the local code will prevail. In Canada refer to the National Building Code or CSA-A405 as applicable.

When the boiler is removed from the common venting system, test to see if the vent system is too large for the remaining appliance. At the time of removal of an existing boiler, the following steps shall be followed with each appliance remaining connected to the common venting system placed in operation, while the other appliances remaining connected to the common venting system are not in operation.

1. Seal any unused openings in the common venting system.

2. Visually inspect the venting system for proper size and horizontal pitch and determine there is no blockage or restriction, leakage, corrosion and other deficiencies which could cause an unsafe condition.

3. Insofar as is practical, close all building doors and windows and all doors between the space in which the appliances remaining connected to the common venting system are located and other spaces of the building. Turn on clothes dryers and any appliance not connected to the common venting system. Turn on any exhaust fans, such as range hoods and bathroom exhausts, so they will operate at maximum speed. Do not operate a summer exhaust fan. Close fireplace dampers.

4. Place in operation the appliance being inspected. Follow the lighting instructions. Adjust thermostat so appliance will operate continuously.

5. Test for spillage at the draft hood relief opening after 5 minutes of main burner operation. Use the flame of a match or candle, or smoke from a cigarette, cigar or pipe.

6. After it has been determined that each appliance remaining connected to the common venting system properly vents when tested as outlined above, return doors, windows, exhaust fans, fireplace dampers and any other gas-burning appliance to their previous condition of use.

7. Any improper operation of the common venting system should be corrected so the installation conforms with the *National Fuel Gas Code, ANSI Z223.1/NFPA 54* and/or *CAN/CSA B149.1, Natural Gas and Propane Installation Code*. When resizing any portion of the common venting system, the common venting system should be resized to approach the minimum size as determined using the appropriate tables in Part 11 of the *National Fuel Gas Code, ANSI Z223.1/NFPA 54* and/or *CAN/CSA B149.1, Natural Gas and Propane Installation Code*.

INDOOR CHIMNEY VENTED BOILERS

NOTE: If boiler is to be direct exhausted through a wall of the boiler room, please see next page.

⚠ WARNING ⚠

All installations of boilers and venting should be done only by a qualified expert and in accordance with the appropriate manual. Installing or venting a boiler or any other gas appliance with improper methods or materials may result in serious injury or death due to fire or asphyxiation from poisonous gases such as carbon monoxide, which is odorless and invisible.

CHIMNEY VENT INSTALLATION (CATEGORY I)

⚠ WARNING ⚠

This boiler shall not be connected to any portion of a mechanical draft system operating under positive pressure.

- Horizontal portions of the venting system shall be supported rigidly every 5 feet and at the elbows. No portion of the vent pipe should have any dips or sags.
- This boiler series is classified as a Category I and the vent installation shall be in accordance with chapters 7 and 10 of the National Fuel Gas Code noted above or applicable provisions of the local building codes.
- Inspect chimney to make certain it is constructed according to NFPA 211. The vent or vent collector shall be Type B or metal pipe having resistance to heat and corrosion not less than that of galvanized sheet steel or aluminum not less than 0.016 inch thick (No. 28 Ga).
- Connect flue pipe from draft hood to chimney. Bolt or screw joints together to avoid sags. Flue pipe should not extend beyond inside wall of chimney. Do not install manual damper in flue pipe or reduce size of flue outlet except as provided by the latest revision of ANSI Z223.1. Protect combustible ceiling and walls near flue pipe with fireproof insulation. Where two or more appliances vent into a common flue, the area of the common flue must be at least equal to the area of the largest flue plus 50 percent of the area of each additional flue.

⚠ WARNING ⚠

Do not connect this Category 1 boiler to a vent system used by a Category III and IV appliance. Do not connect it to vents with mechanical draft systems operating at positive pressure. Improper venting could allow combustion products to collect in the structure during use, resulting in damage, injury, or death.

CHIMNEY LINING

Use a suitably sized Type B1 vent liner or suitable corrugated liner.

⚠ WARNING ⚠

Support vent liner in a masonry chimney. Maintain at least 1" clearance on all sides to reduce the possibility of condensate in vent. Condensate may cause vent to deteriorate, allowing combustion products to collect in the structure, which could result in injury or death.

Vent liner must not block opening where vent connectors from other appliance enter the chimney. Blocked openings will cause combustion products to collect in the structure, resulting in damage, injury, or death.

Do not use unlined masonry chimneys. These increase risk of condensate formation, which may cause the chimney to deteriorate, allowing combustion products to collect in the structure, resulting in damage, injury, or death.

- The following chart shows recommended minimum chimney sizes based the *I=B=R Testing and Rating Standard for Heating Boilers*.

Firing Rate (gph)	Chimney Height*	Nominal Chimney Area	Round Liner Inside Diameter	Square Liner Inside Dimensions
0.6 - 1.3	15'	8" x 8"	6"	6¾" x 6¾"
1.31 - 1.8	15'	8" x 8"	7"	6¾" x 6¾"
1.81 - 2.0	20'	8" x 8"	8"	6¾" x 6¾"
2.1 - 3.0	20'	8" x 12"	10"	6½" x 10½"

* For elevations above 2,000 feet above sea level, add 3 feet to chimney heights.

For additional chimney design and sizing information, consult the ASHRAE HVAC Systems and Applications Handbook, "Chimney, Gas Vent, and Fireplace Systems," of the *National Standard for Chimneys, Fireplaces, Vents and Solid Fuel Burning Appliances, ANSI/NFOA 211*.

2. A draft regulator is recommended with or without a neutral pressure point adjuster in all cases where there is chimney draft present. When flue is under positive pressure, such as with a through-the-wall vent, a draft regulator is not used. When a draft regulator is used, it should be the same diameter as the smoke pipe.

For gas units, a double-acting draft regulator is preferable to a draft diverter. All vent pipe joints and seams operating under positive pressure must be sealed gas tight with minimum 400 F RTV Silicone Rubber Adhesive Sealant. Category III Special Venting System is required.

3. Where draft is present, adjust draft regulator to maintain .01 in breeching. See "*Controlling Excessive Draft*" and **Figure #3** on this page for instructions on controlling excessive draft by means of a neutral pressure point adjuster.

4. Slope pipe up from boiler to chimney not less than 1/4" per foot.

5. Run pipe as directly as possible with a minimum number of elbows.

6. Do not connect to fireplace flue.

7. The end of flue pipe must be flush with the inside face of chimney flue.

8. Support the flue pipe rigidly with substantial hangers plus three sheet metal screws at each pipe joint.

9. The chimney should extend at least two feet above any object within 10 feet and extend at least three feet higher than roof at point of exit.

10. Particular attention should be paid to the point where the flue passes through a wall or ceiling. Such penetration should always be made in accordance with prevailing code requirements.

CONTROLLING EXCESSIVE DRAFT

A neutral pressure point adjuster will reduce excessive draft-regulator air flow which can cause condensation and chimney damage. If draft regulator must be more than slightly open to maintain draft at .01 at breeching, a neutral pressure point adjuster should be installed between the boiler flue collar and the draft regulator. Insert adjuster so that draft regulator is not more than slightly open to maintain draft at .01 in breeching. The adjuster should be constructed so that it is permanently locked in place and cannot be moved accidentally in a manner that will interfere with normal operation of the burner. Do **not** lock adjuster in place until burner firing rate has been established and burner has been adjusted to normal operating conditions.

FIG. 3 – CONTROLLING EXCESSIVE DRAFT WITH A NEUTRAL PRESSURE POINT ADJUSTER

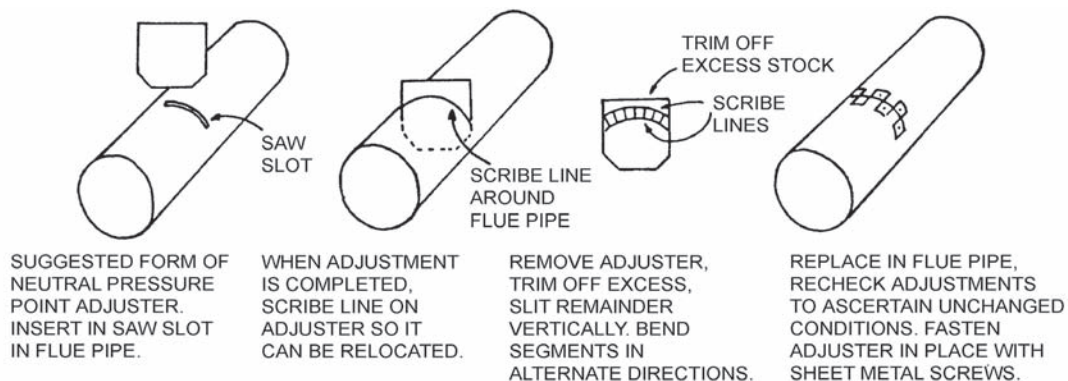

**INDOOR DIRECT EXHAUST BOILERS
— FOR OIL-FIRED BOILERS ONLY!! —**

⚠ WARNING ⚠

Do not vent a gas-fired boiler through a side wall. Gas-fired boilers may only be vented into a chimney (Category I).

Consult with local authorities to ensure compliance with all building, plumbing, and electrical codes.

NOTE: Use standard single wall galvanized metal vent pipe for the vent and air intake piping. A B-Vent shall not be used in the vent system.

The exhaust terminal included in the FDVS kit is a model FDVS stainless steel vent hood. Located on an exterior wall of the building, the exhaust terminal is one of the most important elements of a direct-vent installation. Planning the location of the terminal is the first step. See **Figures #4 and #5**.

The model FDVS vent hood is designed for use on combustible walls up to 8" thick. For combustible walls over 8" thick, consult the boiler manufacturer. The FDVS vent hood may be used on non-combustible walls of any thickness.

IMPORTANT: The FDVS side-wall vent hood requires a 1/2" clearance to combustibles for flue gas temperatures of 450°F or lower and a 1" clearance for temperatures between 450° and 550°F. For flue gas temperatures in excess of 550°F, use of a power venter with the vent hood is recommended.

The optional DES is to be used in conjunction with the boiler for indoor installations requiring through-the-wall venting. The DES is designed as an integral part of the boiler, eliminating the need for a power venter.

Boiler	Kit	Duct Dia.	Wall Opening
3 sections	FDVS 4	4"	6½"
4 to 9 sections	FDVS 6	6"	8½"

Oil boiler DES kits include an oil burner with adjustable post purge timer and solenoid valve. For through-the-wall venting, the post purge burner must be used in place of the standard burner that is furnished with the boiler.

FIG. 4 – TYPICAL DIRECT EXHAUST INSTALLATION (W/BECKETT AFG OIL BURNER)

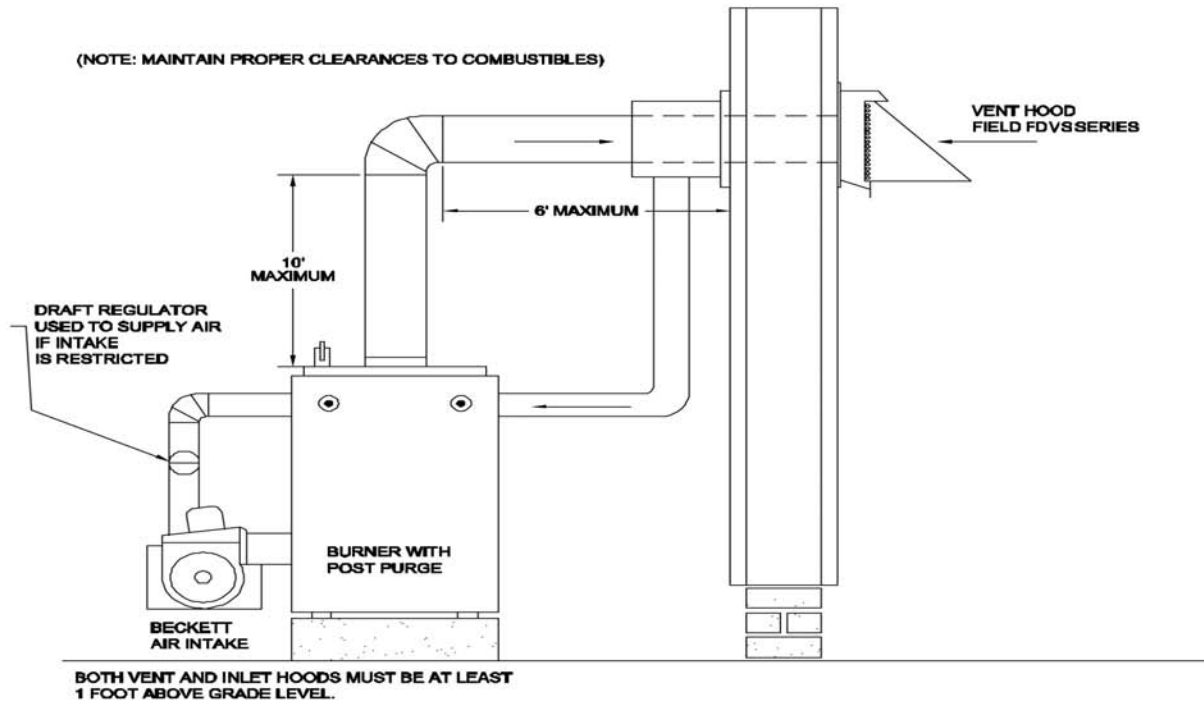
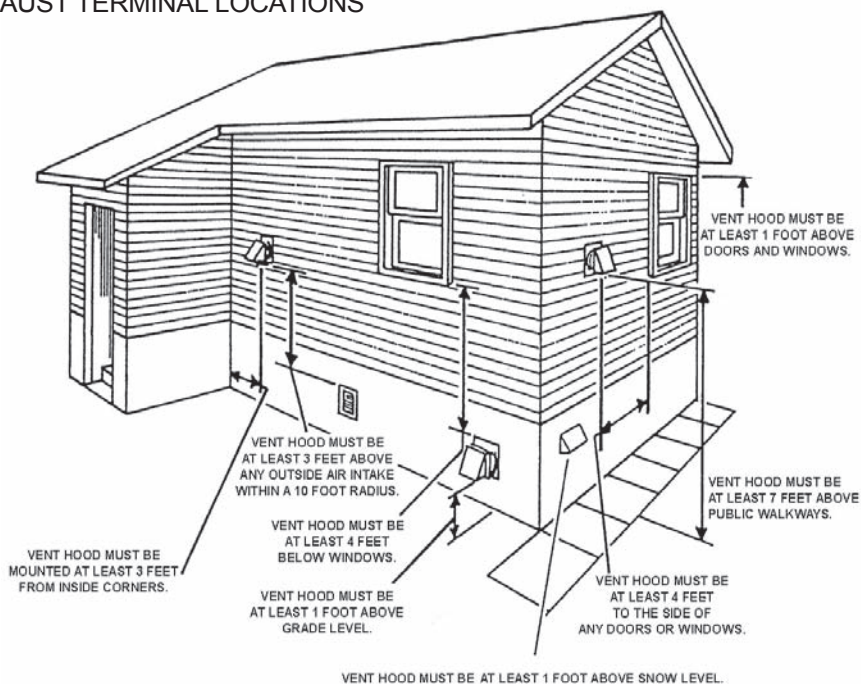

FIG. 5 – EXTERIOR EXHAUST TERMINAL LOCATIONS



NOTES: Location of the termination of the vent pipe shall be in accordance with the National Fuel Gas Code; A.N.S.I., Z223.1 (see requirements below) and any local codes which are applicable. Only one boiler may be exhausted through each vent hood.

- a. The exit terminals of mechanical draft systems shall not be less than 7 feet above grade when located adjacent to public walkways.
- b. A venting system shall terminate at least 3 feet above any forced air inlet located within 10 feet.
- c. The venting system shall terminate at least 4 feet below, 4 feet horizontally from or 1 foot above any door, window or gravity air inlet into any building.

d. An appliance with an input of over 50,000 BTU per hour shall require a 12 inch vent termination clearance from any opening. The bottom of the vent terminal and any air intake shall be located at least 12 inches above grade level.

e. Forced draft systems shall be designed and installed so as to prevent leakage of vent gasses into building.

f. The vent termination point shall not be installed closer than 3 feet from an inside corner of an L-shaped structure.

g. Terminate the vent above normal snow line. Avoid locations where snow may drift and block the vent. Ice or snow may cause the boiler to shut down if the vent becomes obstructed.

LOCATION

The exhaust terminal must be positioned:

- so that spent gases will freely disperse without re-entering the building.
- to permit smoke pipe from the boiler to slope upward not less than 1/4" per foot with no more than a 6' horizontal run.
- in correct relationship to the combustion air inlet. See paragraph 3 in the section titled "Intake Air" for more information.

The exhaust terminal must not be located beneath a porch or crawl space.

CAUTION

The importance of the exhaust terminal location cannot be overemphasized. The exhaust terminal must be located so that prevailing winds cause exhausted flue products to disperse away from the building. A stagnant area where exhaust products can gather or a wind blowing exhaust products back towards the building may cause undesirable odors to enter the building through any available seams or openings, including the vent itself. Exhaust products blown back towards the building may also cause discoloration of building materials. In certain conditions, flue gas will condense and form moisture. When this occurs, steps should be taken to prevent building materials at the exhaust terminal from being damaged by exhausted flue gas.

INSTALLATION

1. Use inside wall end plate as a template to mark hole location. Cut hole 1 inch larger than marked hole to facilitate easy installation.
2. Mount furnished 18" x 18" stainless steel plate on the exterior side of the wall with appropriate type mounting screws. Install vent hood through opening from outside. Fasten the vent hood to the stainless steel plate with appropriate type mounting screws. Caulk as necessary.
3. Fasten wall end plate to the inside wall with appropriate type mounting screws.

INTAKE AIR

1. Intake air is required to support combustion. It must enter the same side of building as the exhaust vent in order to balance wind pressure against the flow of gases.
2. The bottom of the intake duct must be at least 1' above grade level.
3. The intake duct and exhaust vent must be not less than 4' apart unless intake is at least 1' below the level of exhaust, in which case the intake may be at a radius of 2' or more from exhaust.
4. Provide a 4" wall opening and mount 4" intake duct on a flat surface on exterior of wall in the same manner as the exhaust terminal.
5. To supply intake air to the burner:
 - A. When a Beckett Model AFG oil burner is used, run an air duct of 4" smoke pipe (not supplied) from wall inlet directly to burner intake boot with vacuum relief (draft regulator) installed in duct. Use a 4" wrap-around coupling as provided to connect duct to intake boot.
 - B. When a Beckett Model SMG oil burner or a gas burner is used, run intake air duct (without vacuum relief) from wall inlet down to an open end approximately 1' from boiler room floor.

C. When a vacuum relief is not used, note that exhaust fans in use might create a vacuum within the building which can cause improper combustion. Consult factory for assistance as required.

D. See **Figure #4** for typical installation with a Beckett Model AFG post purge oil burner.

EXHAUST FLUE PIPE

The exhaust flue pipe from the boiler must be 6' or less in length in order to minimize condensation. Plan flue pipe configuration to ensure easy disassembly for cleaning of boiler interior.

1. Using silicone rubber, permanently cement a stub of flue pipe 6" to 12" in length to the boiler flue collector. For ease in later disassembly, use a wrap-around coupling as provided to connect the stub to the next section of flue pipe. Connect the remainder of flue pipe in normal fashion.
2. Run flue pipe as directly as possible with a minimum number of elbows. Two 45° elbows will cause less resistance than one 90° elbow.
3. Particular attention should be paid to any point where the flue pipe passes through a wall or ceiling. Such penetrations should always be made in accordance with existing code requirements.
4. At reduced flue pipe sizes, do not use more than two 90° elbows or four 45° elbows, and do not reduce pipe to less than:

Firing Rate	Min. Pipe Diameter
less than 1.00 gph	4"
more than 1.00 gph	6"

5. Support flue pipe rigidly with substantial pipe hangers plus three sheet metal screws at each joint.
6. Seal pipe joints carefully with minimum 400°F RTV silicone sealant or its equal so that no leakage can be detected by the movement of smoke or a small flame held near the joints with burner in operation.

IMPORTANT: Advise owner keep air intake free of obstruction, both indoors and outdoors. Ventilating and combustion air must enter boiler room and burner without restriction.

ALTERNATE UNDERGROUND VENT

When the structure of the house or the exterior grade does not allow location of the vent terminal in compliance with the instructions in this manual, an alternative is to vent into a clay pipe system installed underground. Refer to notes in Figure 6 (below).

FIG. 6 – TYPICAL UNDERGROUND VENT INSTALLATION

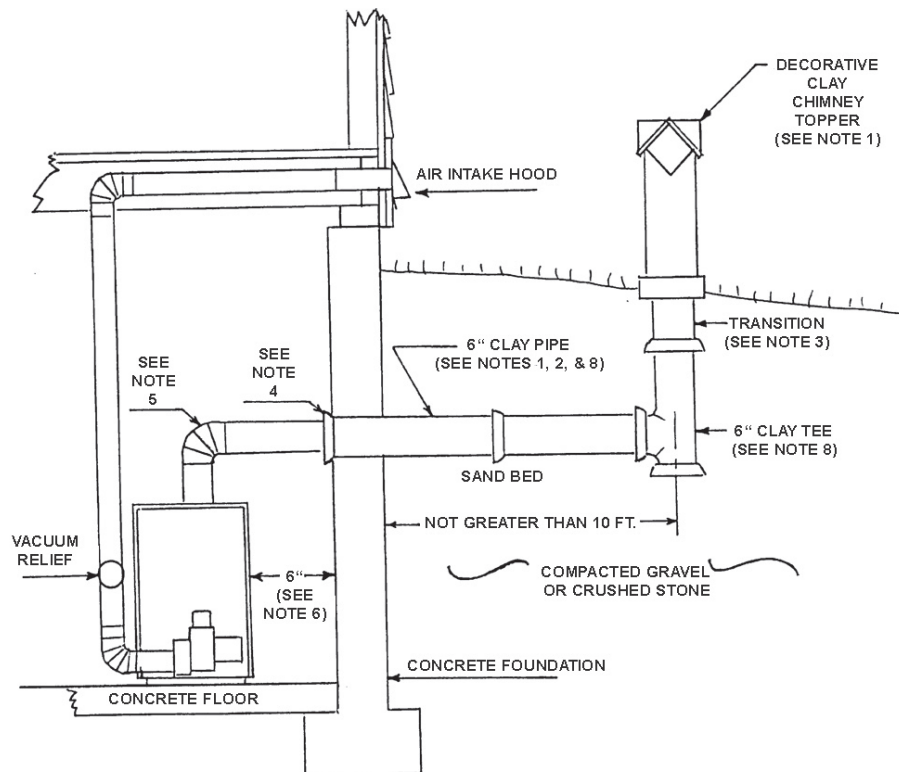

NOTES:

- | | |
|--|--|
| <p>1. Clay chimney topper, tee, and pipe are manufactured by Superior Clay Corp., P.O. Box 352, Uhlrichsville, Ohio, 44683. Clay chimney top devices and pipe from other sources may be used.</p> <p>2. Clay pipe must pitch downward away from foundation $\frac{1}{8}$" to $\frac{1}{4}$" per foot.</p> <p>3. Configuration of transition from tee to topper is dependent on the type of the topper selected and the level of the finished grade. Topper must be removable for cleaning.</p> | <p>4. Seal opening in foundation around clay pipe with hydraulic cement.</p> <p>5. Seal all joints and seams in smoke pipe with silicone rubber.</p> <p>6. When tankless side of boiler must be next to wall, allow enough distance (approx. 18") to remove coil.</p> <p>7. Do not use a draft regulator in flue pipe.</p> <p>8. 6" flue sizes shown on diagram are appropriate for input up to 1.5 gph. 8" flue components may be used for larger firing rates.</p> |
|--|--|