



DCBF-75  
DCBF-100  
DCCF-115  
DCBF-125  
DCCF-150  
DCBF-165  
DCCF-150  
DCCF-205

## CONDENSING GAS FIRED BOILER



**Manufactured by:**  
ECR International Inc.  
2201 Dwyer Avenue, Utica, NY 13501  
Tel. 800 325 5479  
[www.ecrinternational.com](http://www.ecrinternational.com)

DCCF-150



# CONTENTS :

---

*INSTALLATION, OPERATION,  
AND MAINTENANCE MANUAL*  
(240013509)

---

APPLICATION GUIDE  
(240012875)

---

COMMISSIONING  
GUIDE  
(240011376)

---

REQUIRED  
INSPECTION SPECIAL  
(240011561)  
BACK COVER

# DCBF-125







CONDENSING GAS FIRED

## INSTALLATION, OPERATION & MAINTENANCE MANUAL

Models:

**COMBI**

DCCF-115

DCCF-150

DCCF-205

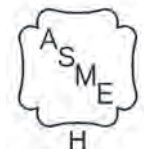
**HEATING ONLY**

DCBF-75

DCBF-100

DCBF-125

DCBF-165



Manufactured by:  
ECR International Inc.  
2201 Dwyer Avenue, Utica, NY 13501  
Tel. 800 325 5479  
[www.ecrinternational.com](http://www.ecrinternational.com)  
PN 240013509 REV. A [03/15/2022]

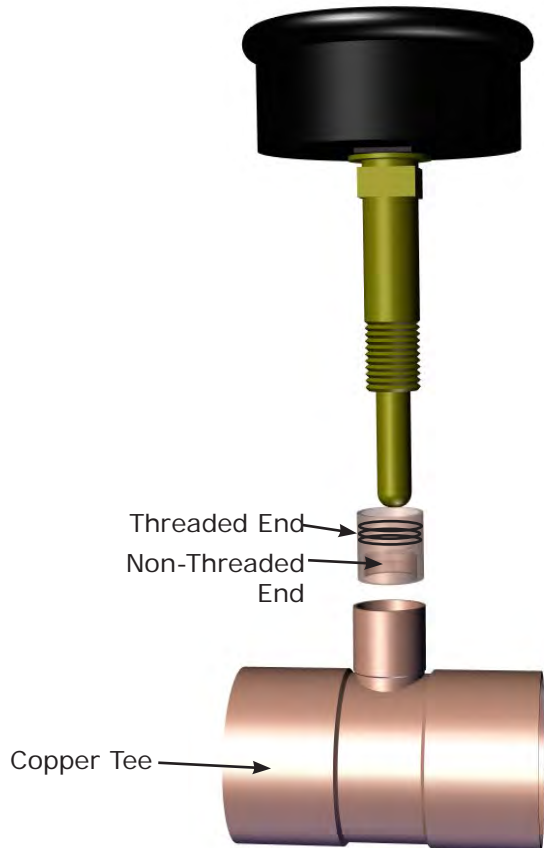
			
<b>Fully Assembled Boiler</b>	<b>30 PSI Safety Relief Valve</b>	<b>Temperature Pressure Gauge (2" Shank)</b>	<b>3/4 NPT Ball Gas Shutoff Valve</b>
			Includes Essential Documents and Warranty 11x17 Wire Diagrams
<b>DHW Optional Pipe Heat Only Boiler</b>	<b>Copper Flush Bushing 1/2" x 1/4" NPT</b>	<b>Copper Tee 1-1/4" x 1-1/4" x 1/2"</b>	

\* Verify proper model size before use.

For Parts lists see manual 240013510 included with your boiler literature package.

**NOTICE**

Using proper brazing or soldering technique, insert copper flush bushing into copper tee with threading up and non-threaded end down. If the threaded end is not UP the TP gauge cannot engage the threads in the bushing.



## TABLE OF CONTENTS

Verify Contents Received.....	2	<b>9 - Start Up Procedure.....</b>	<b>48</b>
Table Of Contents.....	3	9.1 Central Heating System Connections - Heat Only ...	48
Physical Data.....	4	9.2 Central Heating System Connections - Combi.....	48
<b>1 - Important Information.....</b>	<b>7</b>	9.3 System Start Up.....	49
<b>2 - Introduction.....</b>	<b>8</b>	9.4 Fill Condensate Trap With Water .....	49
2.3 Requirements For Commonwealth Of Massachusetts:	8	9.5 Control Panel.....	50
2.4 Use Of Carbon Monoxide Monitor.....	8	9.6 Prior To Commissioning .....	51
2.5 Designated Use .....	8	9.7 Commissioning For The First Time .....	51
2.6 The Unit Must Not:.....	8	9.8 Automatic Calibration Function .....	51
2.7 Operational Features.....	8	9.9 Manual Calibration Function: .....	52
<b>3 - Component Listing .....</b>	<b>9</b>	9.10 De-Aeration Function.....	52
<b>4 - Locating Boiler .....</b>	<b>15</b>	9.11 Changing The Type Of Gas .....	52
4.1 Boiler Location Considerations .....	15	9.12 Chimney Sweep Function .....	53
4.2 Floor Location.....	15	9.13 Combustion Adjustment Function (CO2%).....	53
4.3 Clearances .....	16	9.14 Check Firing Rate.....	54
<b>5 - Combustion Air And Vent Piping.....</b>	<b>17</b>	9.15 Parameter Settings .....	54
5.1 General .....	17	9.16 Description Of Parameters: Factory Settings.....	55
5.2 Removal Of Existing Boiler From Common Vent System .....	18	9.17 Adjusting Maximum Heating Power .....	57
5.3 Definitions .....	18	<b>10 - Operating Instructions .....</b>	<b>58</b>
5.4 Approved Venting Materials .....	19	10.1 Testing For Gas Leaks And Purging Gas Supply .....	58
5.5 Vent Termination .....	19	10.2 Boiler Operation.....	58
5.6 Coaxial Venting Instructions.....	21	10.3 Central Heating Mode .....	58
5.7 Coaxial Vent Screw Placement .....	22	10.4 Domestic Hot Water Mode.....	59
5.8 Twin Pipe Systems.....	23	10.5 Frost Protection .....	59
5.9 Twin Pipe Polypropylene Adapter Kit Installation.....	24	10.6 Pump .....	59
5.10 Twin Pipe CPVC Adapter Kit Installation.....	24	10.7 Low Water Pressure Sensor (Internal) .....	59
5.11 Twin Pipe Polypropylene Adapter Kit Installation.....	25	<b>11 - General Maintenance And Cleaning .....</b>	<b>60</b>
5.12 Twin Pipe CpvC Adapter Kit Installation .....	25	11.1 Beginning Of Each Heating Season.....	60
5.13 Securing Twin Pipe Polypropylene Venting.....	26	11.2 Maintenance And Routine Servicing.....	61
5.14 Flexible Vent System .....	29	11.3 Component Replacement And Cleaning .....	61
5.15 Condensate Piping .....	31	11.4 Draining The Boiler .....	62
<b>6 - Hydronic Piping.....</b>	<b>32</b>	11.5 Draining The Heating Circuit.....	62
6.1 General .....	32	11.6 Hydraulic Unit (DHW) .....	63
6.2 Special Conditions .....	32	11.7 Cleaning The Cold Water Filter.....	63
6.3 Safety Relief Valve And Air Vent .....	33	11.8 Final Commissioning .....	63
6.4 Trim Piping.....	33	11.9 Final Assembly .....	63
6.5 System Piping .....	33	11.10 User Information.....	64
6.6 External Optional Low Water Cut Off .....	35	11.11 Safety Flue Thermostat.....	64
6.7 Manufacturer Recommendation - Strainer.....	36	11.12 Flue Pressure Switch. ....	64
6.8 Central Heating System.....	37	11.13 Replacement Parts .....	64
6.9 Frost Protection Mode.....	37	<b>12 - Ratings And Capacities.....</b>	<b>65</b>
6.11 Pump Protection .....	37	12.1 Ratings And Capacity.....	65
<b>7 - Gas Supply Piping .....</b>	<b>38</b>	12.2 Domestic Hot Water Specifications.....	65
7.1 General .....	38	12.3 High Altitude Ratings.....	66
7.2 Gas Pipe Recommendations .....	39	12.4 High Altitude Chart.....	66
7.3 Leak Check Gas Piping .....	41	12.5 Available Boiler Pump Head.....	67
7.4 Gas Orifice .....	41	<b>13 - Trouble Shooting.....</b>	<b>68</b>
<b>8 - Electrical Connections .....</b>	<b>42</b>	13.1 Error Messages And Resetting The Boiler .....	68
8.1 General .....	42	13.2 Anomalies Table For The Installer - Use This Table To Report The Anomaly Values.....	70
8.2 Electrical Connections .....	42	<b>14 - Glossary .....</b>	<b>71</b>
8.3 Access To Connection Block.....	43	<b>Appendix A - Wiring Diagrams.....</b>	<b>73-78</b>
8.4 Main Supply Connection .....	43		
8.5 Install Room Thermostat .....	44		
8.6 Outdoor Air Sensor (OAS) Electrical Connections.....	44		
8.7 Indirect Storage Tank.....	46		
8.9 Management Of 0-10v Input.....	46		

## PHYSICAL DATA

### DIMENSIONS

DIMENSIONS		75 / 100 / 125	115 / 150	165 / 205
<b>A</b>	Height (Bottom of boiler top of safety Valve)	43.65" [1.09 m]		
<b>B</b>	Overall Width with Manifold	24.70" [628 mm]		
<b>C</b>	Depth	17.46" [444 mm]	23.55" [598 mm]	
<b>D</b>	Condensate Trap Connection	3/4" [19.1 mm] NPT		
<b>E</b>	System Supply	1 1/4" [31.75 mm] Sweat Connection		1 1/2" [38.1 mm] Sweat Connection
<b>F</b>	DHW Outlet (100 & 125 optional)	3/4" [19.1 mm] Copper Sweat	1/2" [15.9 mm] Copper Sweat	165-NA 205 - 3/4" [19.1 mm]
<b>G</b>	Gas Connection	3/4" NPT [19.1 mm]		
<b>H</b>	DHW (Cold Water) Inlet	N/A	1/2" [12.7 mm] Copper Sweat	165 - N/A 205 - 3/4" [19.1 mm]
<b>I</b>	Boiler Return	3/4" [19.1 mm]		1" [38.1 mm]
	Boiler Filling Connection	External to Boiler		
	Primary Water Content	0.95 gal [3.60 L]	1 gal [3.80 L]	1 1/4 gal [4.73 L]

### SYSTEM

Central Heating (Sealed System)	75 / 100 / 115 / 125 / 150 / 165 / 205	
Heat Exchanger Max Allowable Working Pressure	50 psi [3.45 bar]	
Max System Pressure	43 psi [2.96 bar]	
Min System Pressure	7.25 psi [0.50 bar]	
Max System temperature	176°F [80°C]	
Pressure Relief Valve Setting	30 psi [2.11 bar]	
Expansion Tank Minimum Size (pre-charge press.)	(75/100/115) 1.5 gal at 11.6 psi [7.0 L at 0.8 bar]	(125/150/165/205) 2.2 gal at 11.6 psi [10.0 L at 0.8 bar]
Recommended System Pressure (cold)	12 psi [0.83 bar]	

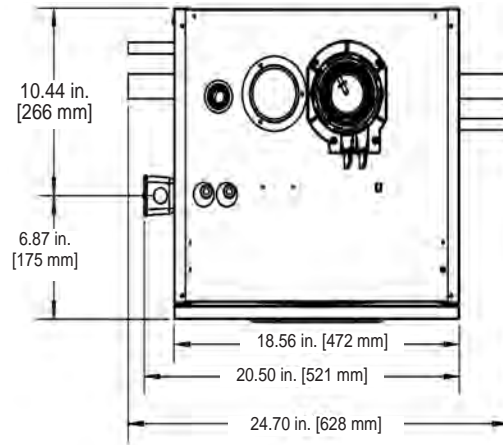
Domestic Hot Water	115	150	205
Max Inlet Water Pressure	116 psi [8 bar]		
Min Inlet Water Pressure	2.9 psi [0.2 bar]		
Min DHW Flow Rate to Activate	0.65 gpm [2.10 L/min]		
Max DHW Temperature	140°F [60°C]		
DHW Flat Plate Water Content	0.035 gal [0.13 L]	0.053 gal [0.23 L]	0.10 gal [0.37 L]

When boiler is operating at maximum operating temperature, providing heating with all heat emitters operating, pressure gauge should not indicate more than 26.11 psi / 1.80 bar. If reading exceeds this figure larger expansion tank is required.

PHYSICAL DATA

MODELS - 75/100/115/125/150

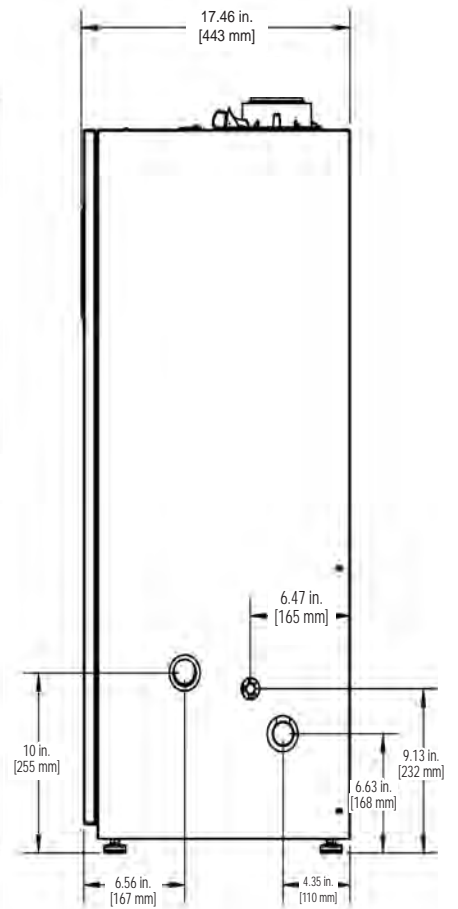
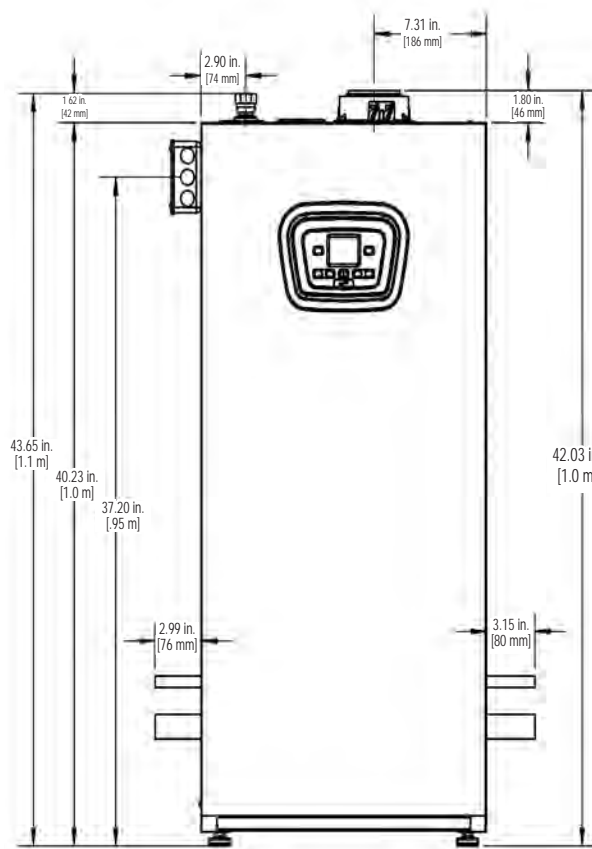
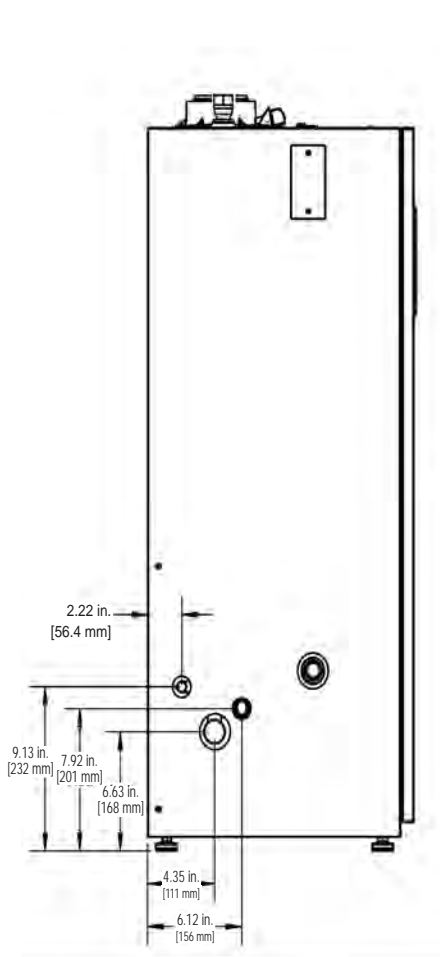
Top View



Left Side View

Front View

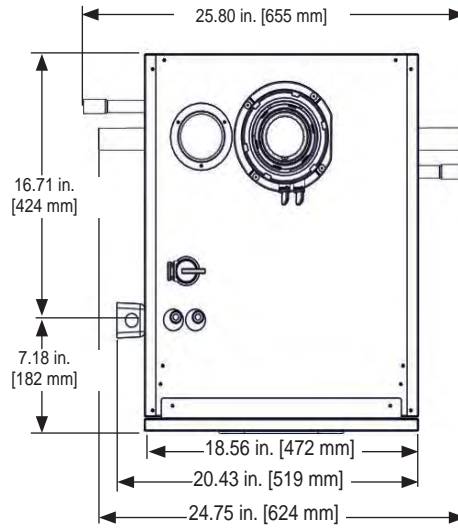
Right Side View



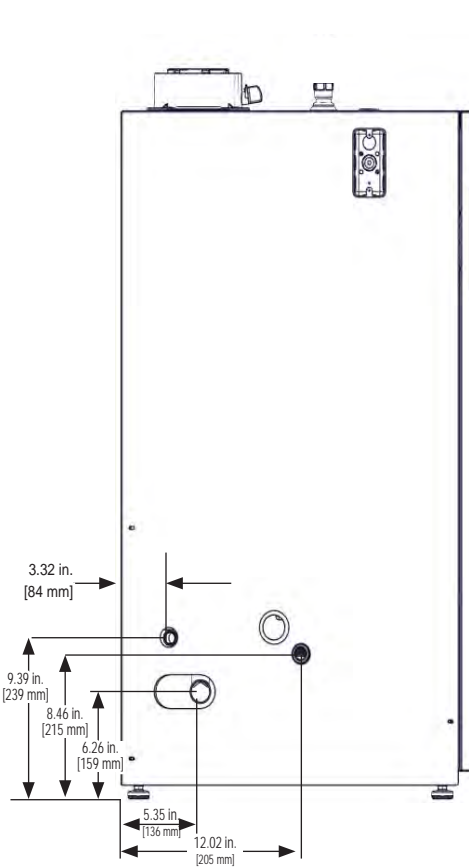
**PHYSICAL DATA**

**MODELS - 165 & 205**

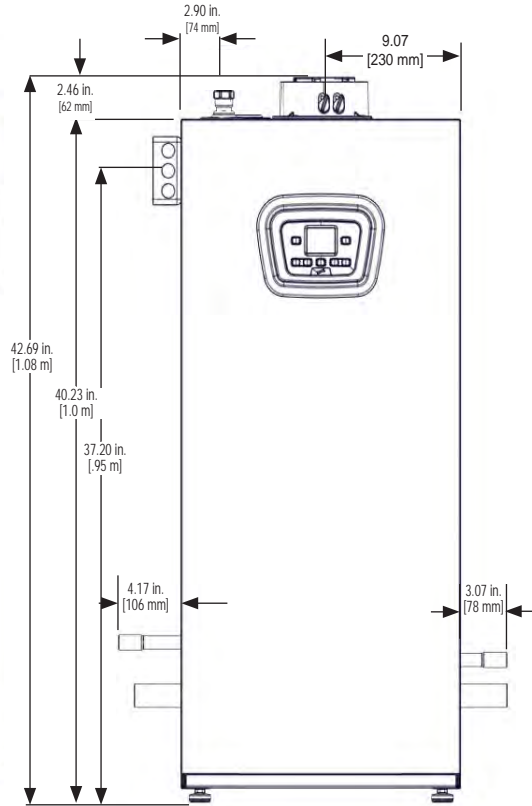
**Top View  
165 & 205**



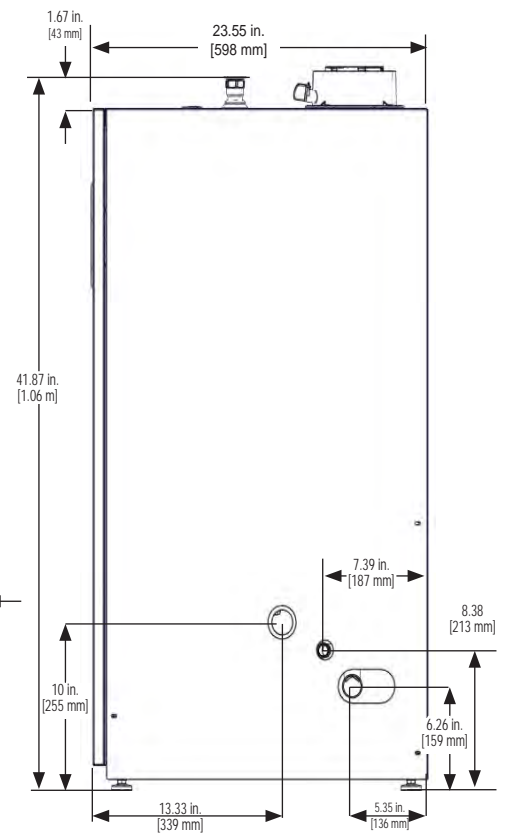
**Left Side View  
165 & 205  
Models**



**Front View  
165 & 205  
Models**




**Right Side View  
165 & 205**





## 1 - IMPORTANT INFORMATION

Become familiar with symbols identifying potential hazards.

 This is the safety alert symbol. Symbol alerts you to potential personal injury hazards. Obey all safety messages following this symbol to avoid possible injury or death.

### **DANGER**

Indicates a hazardous situation which, if not avoided, **WILL** result in death or serious injury.

### **WARNING**

Indicates a hazardous situation which, if not avoided, could result in death or serious injury.

### **CAUTION**

Indicates a hazardous situation which, if not avoided, could result in minor or moderate injury.

### **NOTICE**

Used to address practices not related to personal injury.

### 1. Safety Information

Boiler installation shall be completed by qualified agency. See glossary for additional information.

### **WARNING**

Fire, explosion, asphyxiation and electrical shock hazard. Improper installation could result in death or serious injury. Read this manual and understand all requirements before beginning installation.

### **WARNING**

Do not tamper with or use this boiler for any purpose other than its intended use. Failure to follow these instructions could result in death or serious injury. Use only manufacturer recommended parts and accessories.

### **WARNING**

Fire, Explosion, Asphyxiation, Electrical shock hazard! Flooding will result in damages such as electrical problems, corrosion, inoperative parts, mold and other unforeseen issues which can occur over time. Any equipment determined by a professional as damaged by a flood, defined as excess of water or other liquid, shall be replaced. Failure to follow these directions will result in a Hazardous Situation.

### **CAUTION**

Laceration, burn hazard. Metal edges and parts may have sharp edges and/or may be hot. Use appropriate personal protection equipment to include safety glasses and gloves when installing or servicing this boiler. Failure to follow these instructions could result in minor or moderate injury.

FOR YOUR SAFETY READ BEFORE OPERATING

# **DANGER**



### **Hot Water Can Scald!**

Water heated to temperature for clothes washing, dish washing and other sanitizing needs can scald and cause permanent injury.

Children, elderly, and infirmed or physically handicapped persons are more likely to be permanently injured by hot water. Never leave them unattended in bathtub or shower. Never allow small children to use a hot water tap or draw their own bath.

If anyone using hot water in the building fits the above description, or if state laws or local codes require certain water temperatures at hot water taps, you must take special precautions:

- Use lowest possible temperature setting.
- Install some type of tempering device, such as an automatic mixing valve, at hot water tap or water heater. Automatic mixing valve must be selected and installed according to manufacturer's recommendations and instructions.
- Water passing out of drain valves may be extremely hot. To avoid injury:
  - Make sure all connections are tight.
  - Direct water flow away from any person.

Water Temperature Setting	1st Degree Burn Exposure Time For An Adult	2nd and 3rd Degree Burn Exposure Time For An Adult
120° F	1 minute	5 minutes
130° F	5 seconds	30 seconds
140° F	2 seconds	5 seconds
150° F	1 second	1.5 seconds
160° F	Instantaneous	0.5 seconds

**Note:** Warning for Infants, Children, and Elderly: Great care must be taken when exposing the aforementioned groups to warm or hot water as they can be badly burned in exposure times less than half of the time for an adult.

### 2 - Introduction

**2.1** Installation shall conform to requirements of authority having jurisdiction or in absence of such requirements:

#### UNITED STATES

- National Fuel Gas Code, ANSI Z223.1/NFPA 54.
- National Electrical Code, NFPA 70.

#### CANADA

- Natural Gas and Propane Installation Code, CAN/CSA B149.1.
- Canadian Electrical Code, Part I, Safety Standard for Electrical Installations, CSA C22.1

**2.2** Where required by authority having jurisdiction, installation shall conform to Standard for Controls and Safety Devices for Automatically Fired Boilers, ANSI/ASME CSD-1. Boiler internal low water cutoff device does not qualify for CSD1

Additional manual reset low water cutoff may be required.

#### **2.3 Requirements for Commonwealth of Massachusetts:**

Boiler installation must conform to Commonwealth of Massachusetts code 248 CMR which includes but is not limited to:

Installation by licensed plumber or gas fitter.

#### **2.4 Manufacturer recommends use of Carbon Monoxide monitor may be requirement of local jurisdiction.**

#### **2.5 Designated Use**

- **DCCF-115**, **DCCF-150** and **DCCF-205** provide both central heating and domestic hot water.
- **DCBF-75**, **DCBF-100**, **DCBF-125** and **DCBF-165** central heating only.
- Indoor installation.
- Closet or alcove installation. Direct Vent Boiler does not require air vents when installed in closet or room.
- Direct vent boiler.
- For use with natural gas or liquefied petroleum gases (LP/propane).

#### **2.6 The unit MUST NOT:**

- Directly heat potable water. Indirect heating is acceptable.
- Heat water with non-hydronic heating system chemicals present (example, swimming pool water).
- Toxic chemicals, such as those used for boiler treatment, shall not be introduced into potable water.
- Exceed 43 psig (2.96 bar) maximum system pressure, or drop below minimum system pressure 7.25 psig (.50 bar)
- Exceed 176°F (80°C) system design temperature.

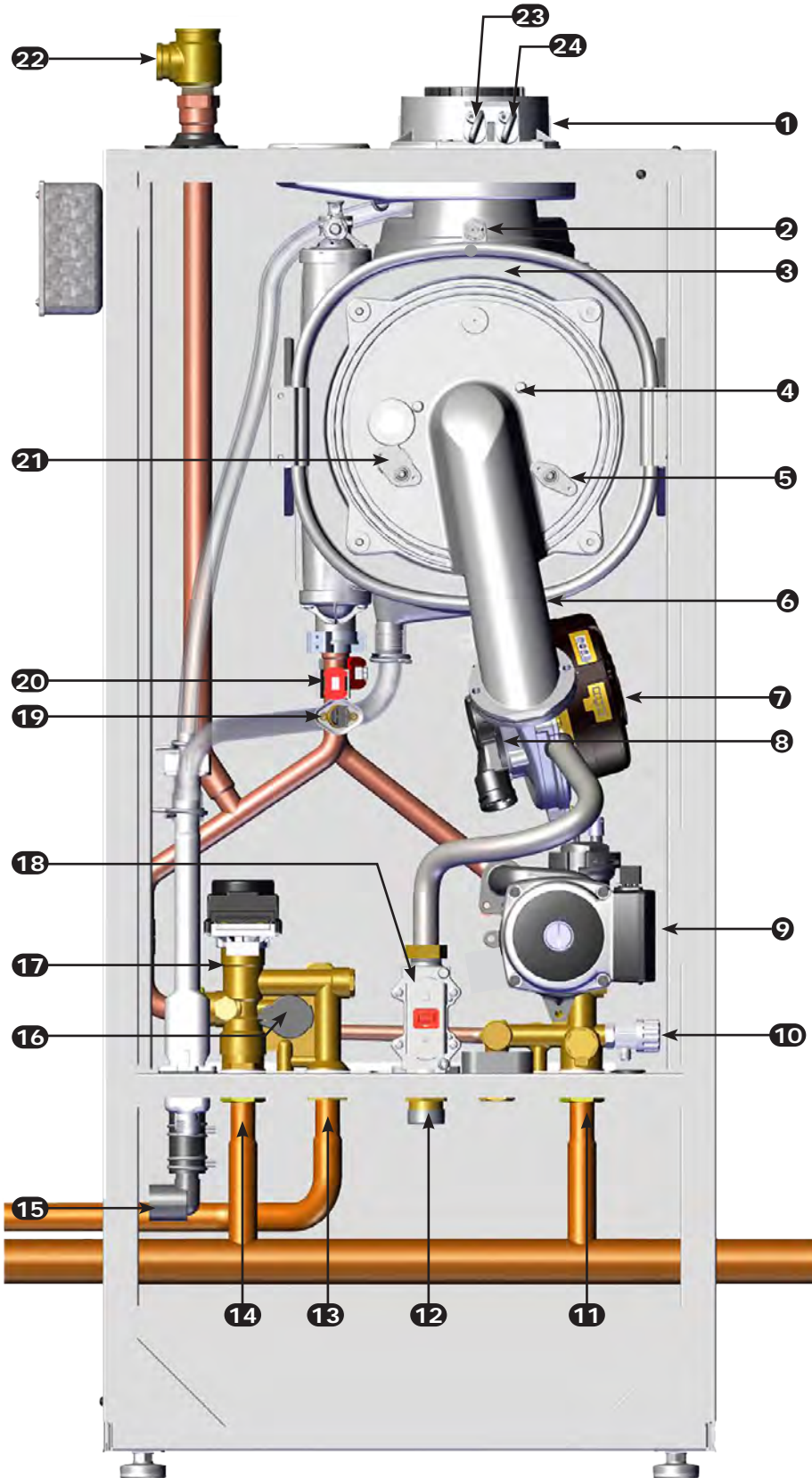
#### **2.7 Operational Features**

- **DCBF-75** Modulates input to provide CH Turndown 4.5:1.
- **DCBF-100** Modulates input to provide CH Turndown 5.6:1
- **DCCF-115** Modulates input to provide CH Turndown 5.6:1, DHW Turndown 6.9:1
- **DCBF-125** Modulates input to provide CH Turndown 5.7:1
- **DCCF-150** Modulates input to provide CH Turndown 5.7:1, DHW Turndown 7:1
- **DCBF-165** Modulates input to provide CH Turndown 5.5:1
- **DCCF-205** Modulates input to provide CH Turndown 5.5:1, DHW turndown 7:1
- Maximum output available for domestic hot water:
  - DCCF-115** - 105,500 btu/hr (33.8 kW) capable of providing 2.5 (U.S.) gpm (11.4 liters/min) with a temperature rise of 70°F/39°C.
  - DCCF-150** - 136,000 btu/h (40 kW), capable of providing 3.5 (U.S.) gpm (13.2 liters/min) with a temperature rise of 70°F/39°C.
  - DCCF-205** - 180,000 btu/h (53 kW), capable of providing 5.0 (U.S.) gpm (18.9 liters/min) with temperature rise of 70°F/39°C.
- Integral Low Water Pressure Cutoff.
- Optional Outdoor Temperature Reset.
- Heat exchanger over heat protection.
- Boiler operating at maximum operating temperature, providing heat, pressure gauge should not indicate more than 26.11 psi / 1.80 bar. If reading exceeds this figure larger expansion tank is required.

Check our website frequently for updates: [www.ecrinternational.com](http://www.ecrinternational.com)

**Information and specifications outlined in this manual in effect at the time of printing of this manual. ECR International reserves the right to discontinue, change specifications or system design at any time without notice and without incurring any obligation, whatsoever.**

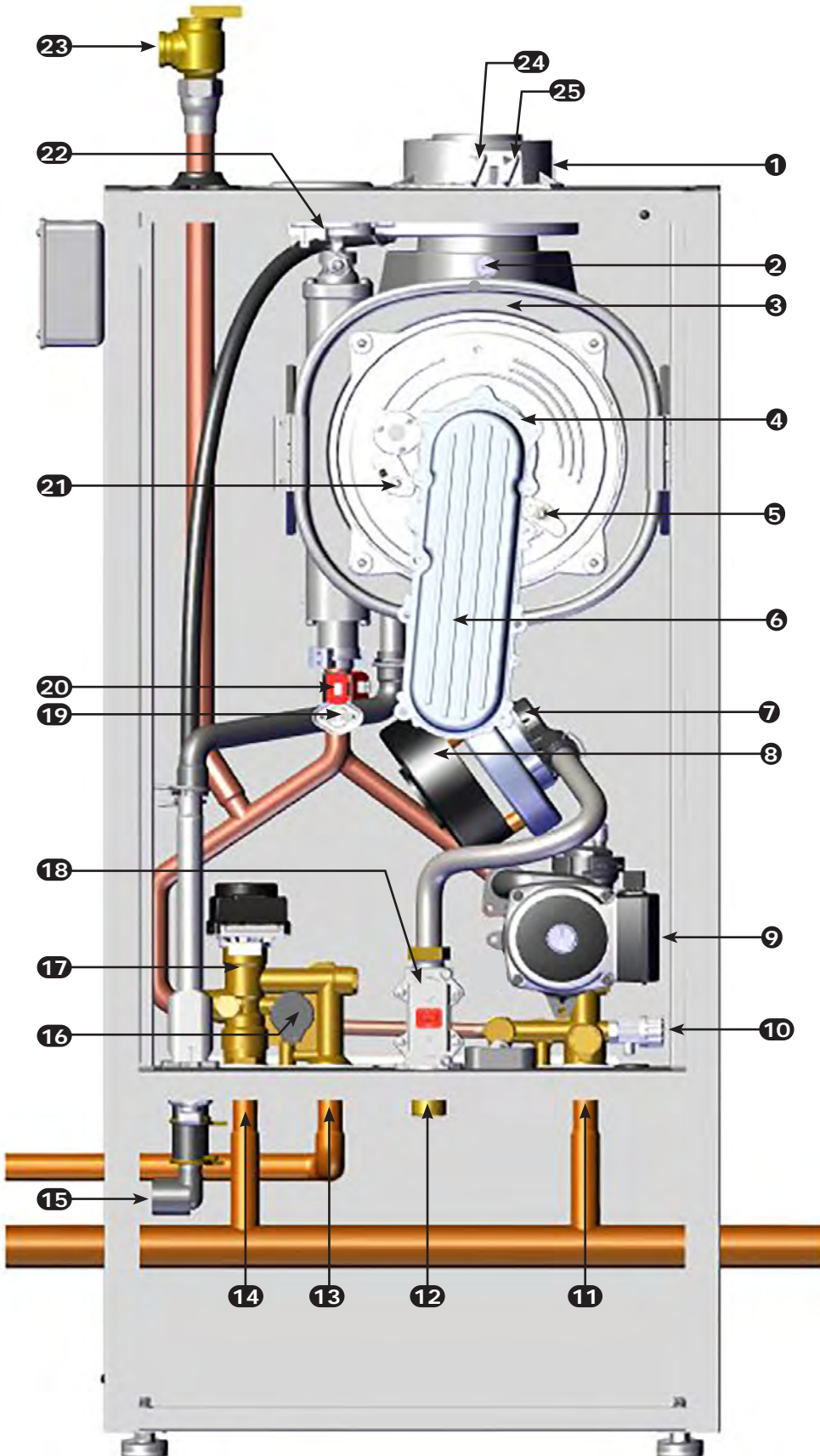
# DUNKIRK DCBF 75 & 100



ITEM NO.	Dunkirk DCBF-75 & 100
1	Coaxial Connector
2	Flue Sensor
3	Heat Exchanger
4	Burner (not shown)
5	Flame Detection Electrode
6	Air/Gas Blend Manifold
7	Fan
8	Venturi
9	Pump with Air Separator
10	Boiler Drain Tap
11	Heating Return
12	Gas Inlet
13	Optional Indirect Tank Connection
14	Heating Supply Connection
15	Condensate Connection
16	Low Water Pressure Cutoff
17	3-Way Valve with Motor
18	Gas Valve
19	Over Temperature Thermostat
20	NTC Heating Sensor
21	Ignition Electrode
22	Pressure Relief Valve
23	Exhaust Test Port
24	Intake Test Port



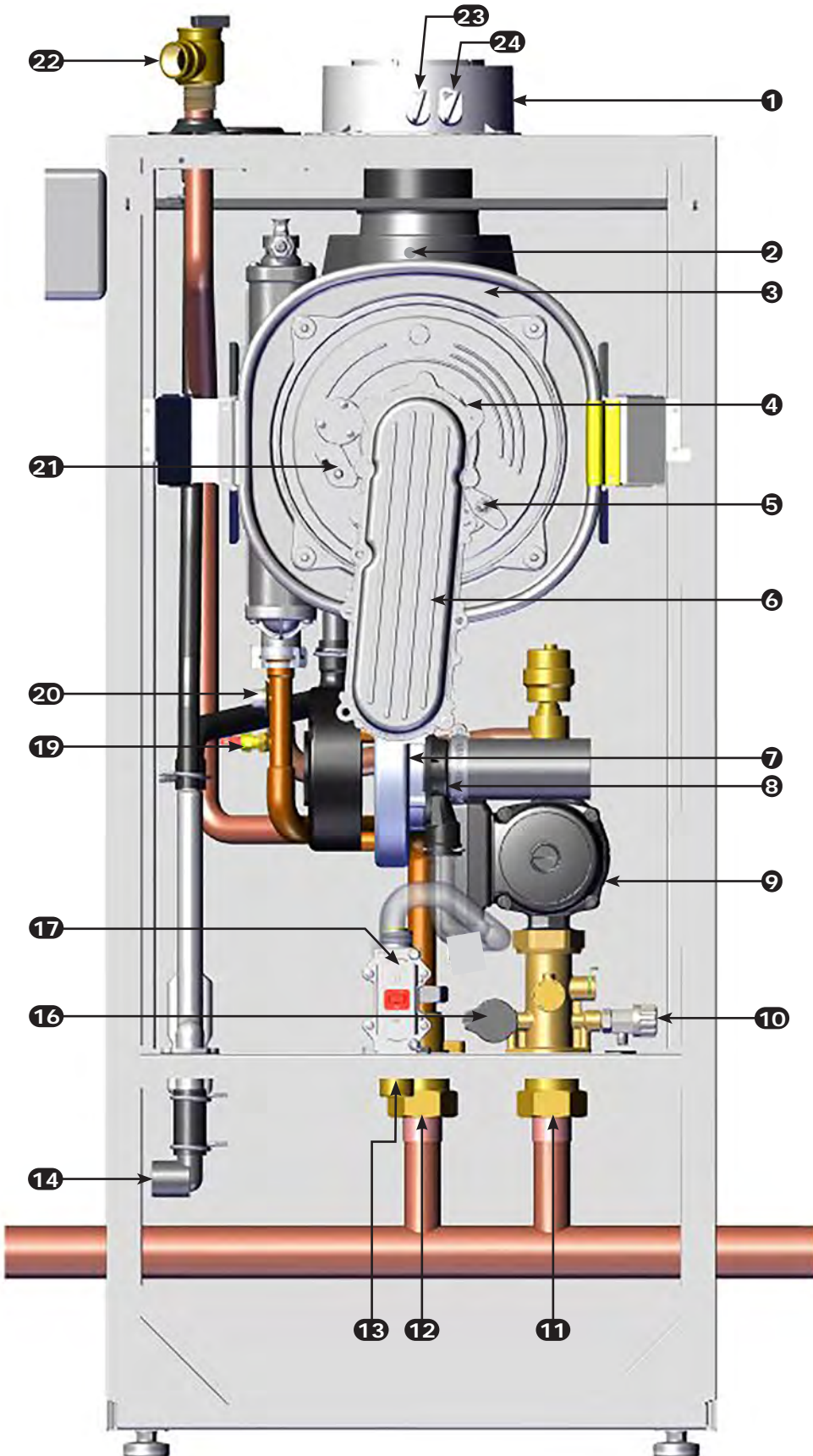
# DUNKIRK DCBF-125



ITEM NO.	Dunkirk DCBF-125
1	Coaxial Connector
2	Flue Sensor
3	Heat Exchanger
4	Burner (not shown)
5	Flame Detection Electrode
6	Air/Gas Blend Manifold
7	Venturi
8	Fan
9	Pump with Air Separator
10	Boiler Drain Tap
11	Heating Return
12	Gas Inlet
13	Optional Indirect Tank Connection
14	Heating Supply Connection
15	Condensate Connection
16	Low Water Pressure Cutoff
17	3-Way Valve with Motor
18	Gas Valve
19	Water Safety Thermostat
20	NTC Heating sensor (Return) QTY 2, (1 Shown for clarity)
21	Ignition Electrode
22	Pressure Switch
23	Pressure Relief Valve
24	Exhaust Test Port
25	Intake Test Port

Illustrations are a depiction of the boiler for general location of parts and may vary depending on model.

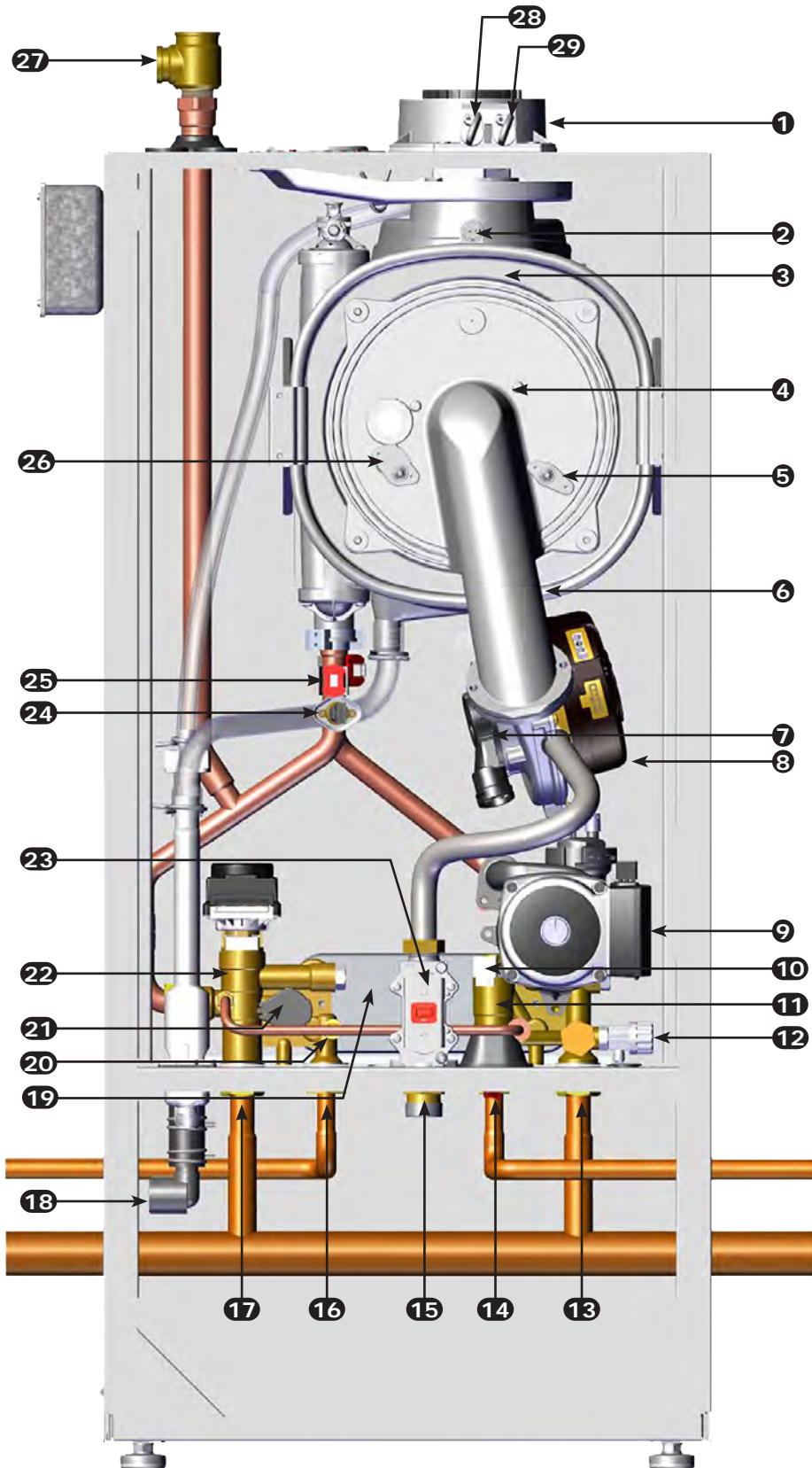
# DUNKIRK DCBF-165



ITEM NO.	Dunkirk DCBF-165
1	Coaxial Connector
2	Flue Sensor
3	Heat Exchanger
4	Burner (not shown)
5	Flame Detection Electrode
6	Air/Gas Blend Manifold
7	Fan
8	Venturi
9	Pump with Air Separator
10	Boiler Drain Tap
11	Heating Return
12	Heating Supply Connection
13	Gas Inlet
14	Condensate Connection
15	Low Water Pressure Cutoff
16	Inlet Element
17	Gas Valve
19	Over Temperature Thermostat
20	NTC Heating Sensor
21	Ignition Electrode
22	Pressure Relief Valve
23	Exhaust Test Port
24	Intake Test Port

Illustrations are a depiction of the boiler for general location of parts and may vary depending on model.

# DUNKIRK DCCF-115

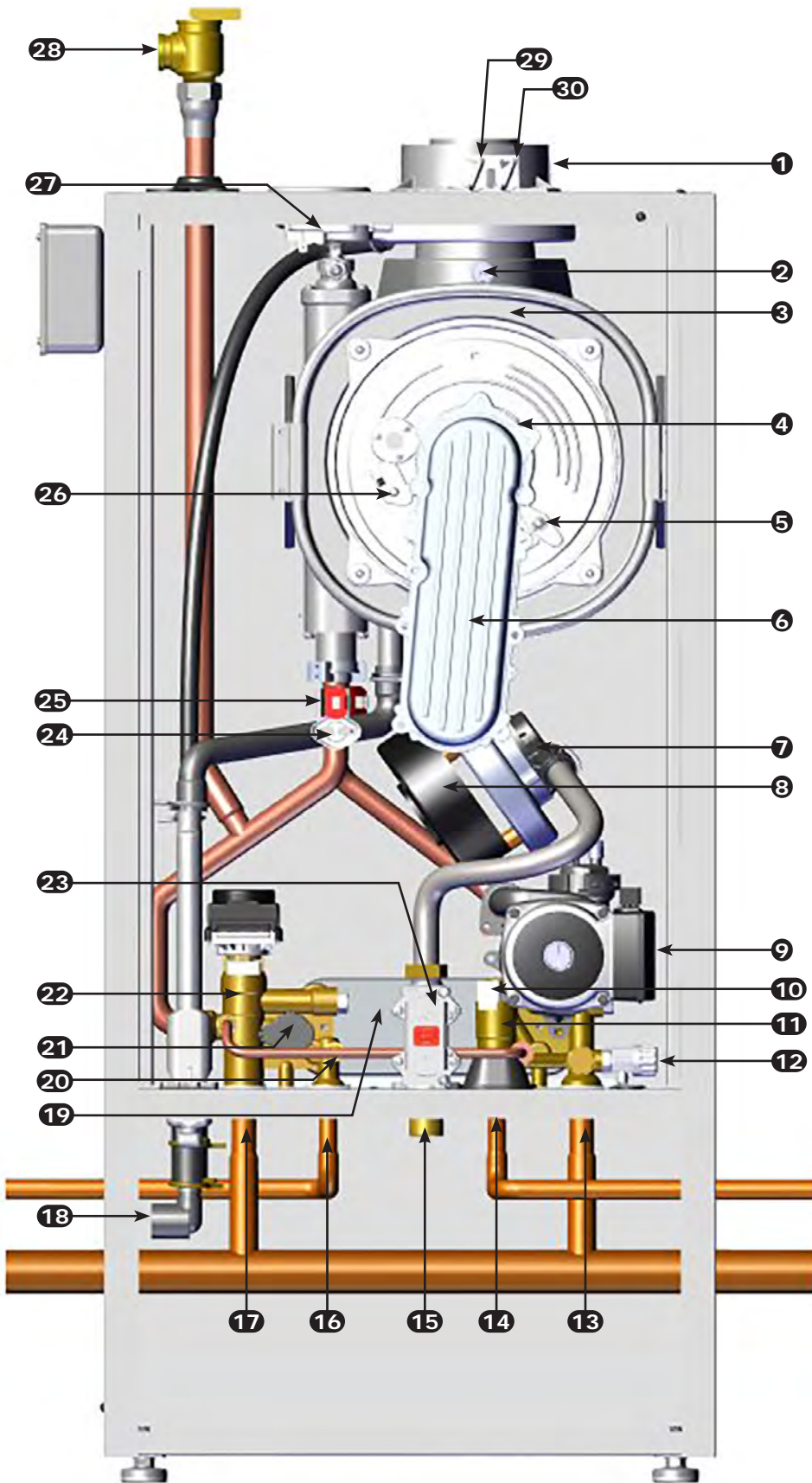


ITEM NO.	Dunkirk DCCF-150
1	Coaxial Connector
2	Flue Sensor
3	Heat Exchanger
4	Burner (not shown)
5	Flame Detection Electrode
6	Air/Gas Blend Manifold
7	Venturi
8	Fan
9	Pump with Air Separator
10	DHW Priority Sensor
11	Flow Sensor with Water Filter and Flow Restrictor
12	Boiler Drain Tap
13	Heating Return
14	Cold Water DHW Inlet
15	Gas Inlet
16	DHW Outlet
17	Heating Supply
18	Condensate Connection
19	DHW Heat Exchanger
20	NTC DHW Sensor
21	Low Water Pressure Cutoff
22	3-Way Valve with Motor
23	Gas Valve
24	Water Safety Thermostat
25	NTC Heating sensor (Return) QTY 2, (1 Shown for clarity)
26	Ignition Electrode
27	Pressure Relief Valve
28	Exhaust Test Port
29	Intake Test Port

Illustrations are a depiction of the boiler for general location of parts and may vary depending on model.



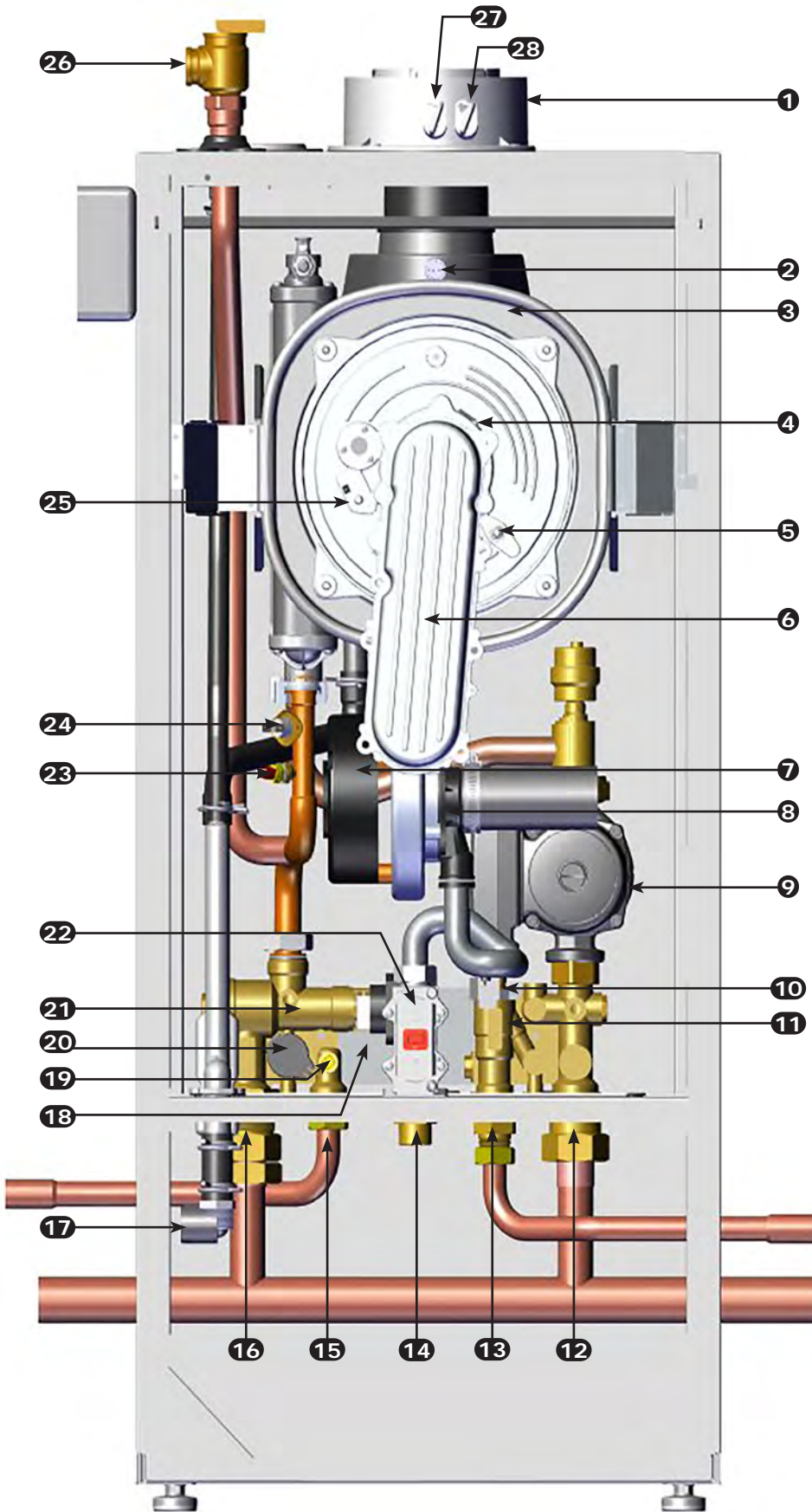
# DUNKIRK DCCF-150



ITEM NO.	Dunkirk DCCF-150
1	Coaxial Connector
2	Flue Sensor
3	Heat Exchanger
4	Burner (not shown)
5	Flame Detection Electrode
6	Air/Gas Blend Manifold
7	Venturi
8	Fan
9	Pump with Air Separator
10	DHW Priority Sensor
11	Flow Sensor with Water Filter and Flow Restrictor
12	Boiler Drain Tap
13	Heating Return
14	Cold Water DHW Inlet
15	Gas Inlet
16	DHW Outlet
17	Heating Supply
18	Condensate Connection
19	DHW Heat Exchanger
20	NTC DHW Sensor
21	Low Water Pressure Cutoff
22	3-Way Valve with Motor
23	Gas Valve
24	Water Safety Thermostat
25	NTC Heating sensor (Return) QTY 2, (1 Shown for clarity)
26	Ignition Electrode
27	Pressure Switch
28	Pressure Relief Valve
29	Exhaust Test Port
30	Intake Test Port

Illustrations are a depiction of the boiler for general location of parts and may vary depending on model.

# DUNKIRK DCCF-205



ITEM NO.	Dunkirk DCCF-205
1	Coaxial Connector
2	Flue Sensor
3	Heat Exchanger
4	Burner (not shown)
5	Flame Detection Electrode
6	Air/Gas Blend Manifold
7	Fan
8	Venturi
9	Pump with Air Separator
10	DHW Priority Sensor
11	Flow Sensor with Water Filter and Flow Restrictor
12	Heating Return
13	Cold Water DHW Inlet Tap
14	Gas Inlet
15	DHW Outlet
16	Heating Supply Connection
17	Condensate Connection
18	DHW Heat Exchanger
19	NTC DHW Sensor
20	Low Water Pressure Cutoff
21	3-Way Valve with Motor
22	Gas Valve
23	NTC Heating sensor (Flow/Return) QTY 2, (1 Shown for clarity)
24	Water Safety Thermostat
25	Ignition Electrode
26	Pressure Relief Valve
27	Exhaust Test Port
28	Intake Test Port

Illustrations are a depiction of the boiler for general location of parts and may vary depending on model.

**⚠ WARNING**

Fire hazard. Do not install boiler on combustible flooring or carpeting. Failure to follow these instructions could result in death or serious injury.

**⚠ WARNING**

Fire, explosion, and asphyxiation hazard. Improper installation could result in death or serious injury. Read these instructions and understand all requirements before beginning installation.

**4.1 Boiler Location Considerations**

- Ambient room temperature always maintain above 32°F (0°C) to prevent freezing of liquid condensate.
- Approved for installation in closets or alcove provided it is correctly designed for that purpose and minimum clearances are met.
- Protect gas ignition system components from water (dripping, spraying, rain, etc.) during operation and service (circulator replacement, condensate trap, control replacement, etc.).
- Access to outdoors to meet minimum and maximum pipe lengths for combustion air and vent piping. See section 5.
- Disposal of condensate. See section 5.
- Drainage of water (or water - antifreeze solution) during boiler service or from safety relief valve discharge. See section 6.
- Access to system water piping, gas supply, and electrical service. See sections 6, 7 and 8.
- Clearances to combustible materials and service clearances. See Table 1 and Figures pg. 16.
- Room-sealed boiler installed in room containing bath or shower shall be installed so person using bath or shower cannot touch any electrical switch or boiler control utilizing line voltage electricity.
- Multiple Boilers can be placed side by side, or back to back.
- Observe service clearances in all installations.
- For Direct Vent installations, air vents are not required in room boiler is installed in, or when installed in closet or compartment.
- Requires fresh air intake piped from outdoors.
- Install filter on air intake if boiler is installed in dusty or dirty environment. A high flow air filter with minimum air filtration of 800 CFM can be placed on air intake section of vent pipe.
- Use of unregulated gas (well gas) is not manufacturer recommended with this boiler.

**4.2 Floor Location**

- Place crated boiler as close to selected location as possible and uncrate boiler. Boiler may be moved into position with appliance dolly or (2) two wheel hand truck. Insert dolly or hand truck under left hand side of boiler. It is possible to slide boiler for short distance on smooth floor or surface.
- Adjust the position of the boiler, verify it is level and plumb.
- Select level location central to piping systems served and as close to vent and air intake terminals as possible.
- Accessibility clearances, if more stringent (i.e. larger clearances) than required fire protection clearances, shall be used for boiler installation. Accessibility clearances may be achieved with the use of removable walls or partitions.
- Boiler is approved for installation in closets and on combustible floors. ***This boiler shall NOT be installed on carpeting.***
- Install equipment in location which facilitates operation of venting and combustion air intake piping systems as described in this manual.
- Advise owner to keep venting and combustion air intake passages free of obstructions. Both venting and combustion air intake piping systems connected to outdoors must permit flow through piping systems without restrictions for boiler operation.
- Keep boiler area clean of debris and free of flammable and combustible materials, vapors and liquids.

## 4 - LOCATING BOILER

### 4.3 Clearances

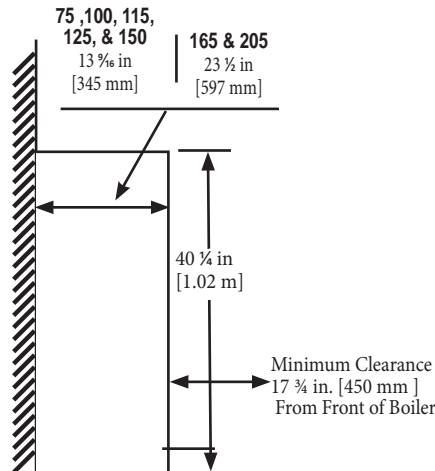
<b>TABLE 1: BOILER CLEARANCES</b>		
Dimension	Combustible Materials <sup>(1)</sup>	Manufacturer Recommended for Service <sup>(1)(2)</sup>
Top	0" (0 cm)	8-5/8" (220 mm)
Left Side	1-3/4" (45 mm)	12" (305 mm)
Right Side	1-3/4" (45 mm)	1-3/4" (45 mm)
Front	0" (0 mm)	17-3/4" (450 mm)
Back	0" (0 mm)	0" (0 mm)
Bottom	0" (0 mm)	0" (0 mm)
Combustion Air/Vent piping	0" (0 mm)	6" (160 mm)

<sup>(1)</sup> Required distances measured from boiler jacket.  
<sup>(2)</sup> Service, proper operation clearance recommendation.  
 \* Allowance for piping and venting not included.

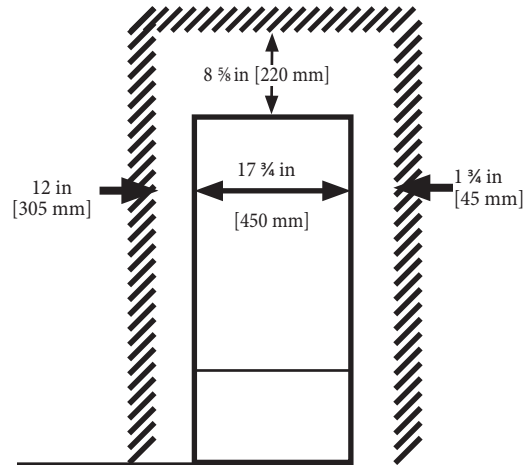
NOTE: Greater clearances for access should supersede fire protection clearances.

### Service Clearances

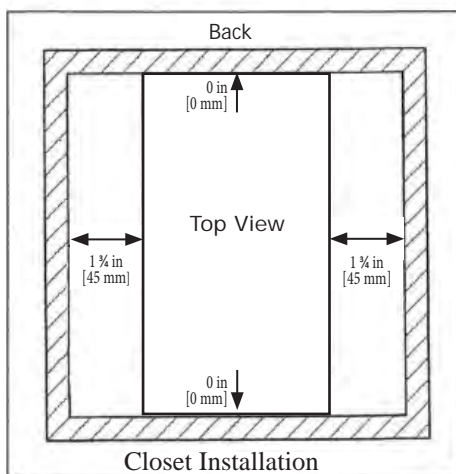
Left Side View of Boiler



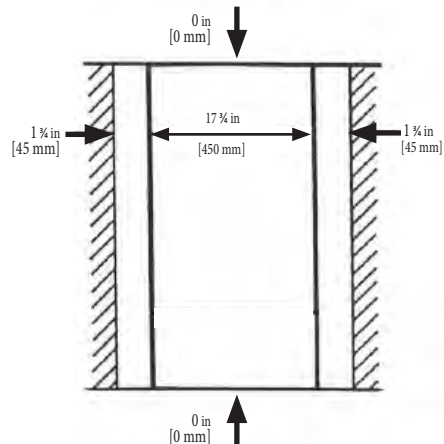
Front View of Boiler



### Combustible Clearances



0 in / 0 mm between Back of Unit and wall



Front View of Boiler



**! WARNING**

Fire, explosion, and asphyxiation hazard. Improper installation could result in death or serious injury. Read these instructions and understand all requirements before beginning installation.

**! WARNING**

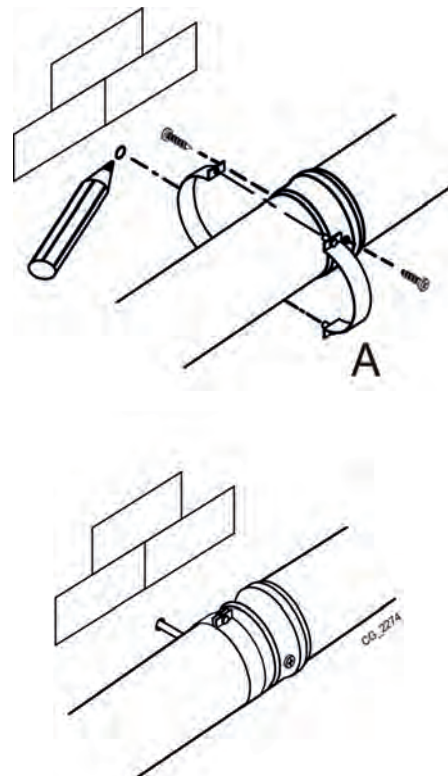
ABS/PVC venting shall not to be used this product. Use of DWV plumbing pipes to vent this boiler shall be prohibited. Use of cellular core PVC (ASTM F891), cellular core CPVC, or Radel® (polyphenolsulfone) in venting systems shall be prohibited. Covering non-metallic vent pipe and fittings with thermal insulation shall be prohibited. Failure to follow these instructions could result in death or serious injury.

- Support piping in accordance with pipe manufacturer's instruction and authority having jurisdiction. In absence of manufacturer's instruction use pipe hooks, pipe straps, brackets, or hangers of adequate and strength located at intervals of 3 ft (1 m) or less. Allow for expansion/ contraction of pipe.
- Venting shall be supported adjacent to each joint using steel strapping or equivalent. See Figure 5-1.
- Support horizontal sections of vent pipe to prevent sags capable of accumulating condensate.
- Assemble vent materials in accordance with venting manufacturer's instructions.
- Slope exhaust pipe minimum of 1/4" per foot, or vent manufacturer's recommendation, whichever is greater; back toward the boiler.
- Any "in line" elbows in flue system must be taken into consideration. First elbow on the top of the boiler is included in equivalent length calculations.
- Use U.V. stabilized polypropylene when it will be exposed to sunlight, wind, or prone to freeze ups.
- Check for proper joint construction when joining pipe to fittings.
- Manufacturer requires use of an approved mechanical fastener, which may vary per vent pipe manufacturer, at every push-fit gasket connection when using a single wall polypropylene vent system.
- Refer to specific vent manufacturer's manual for additional support.

**5.1 General**

- Installations shall comply with Authority having jurisdiction and in absence of such with:
  - » U.S. ANSI Z223.1 /NFPA 54 in the United States
  - » CSA B149.1 in Canada.
- This boiler requires a dedicated direct vent system.
- Vent connections serving appliances vented by natural draft shall not be connected into any portion of mechanical draft systems operating under positive pressure.
- Use only manufacturer approved venting materials or venting materials primer and glue approved to: ULC S636 in Canada, or UL 1738 in the U.S.
- Materials used in the U.S. shall comply with Authority having jurisdiction and in absence of such with: ANSI/ASTM D1785, ANSI/ASTM F441, ANSI/ASTM F493.
- Vent system must have unrestricted movement through walls, ceilings and roof penetrations.
- Check for proper joint construction when joining pipe to fittings.
- If vent is penetrating ceilings and floors, openings must have means of fire stopping in joist areas and proper fire-stop spacer assemblies installed.
- Standard roof flashing methods must be used to install roof flashing.
- Frame wall and roof openings to provide support for attachment of termination assemblies.

**Figure 5-1 - Venting Support**



### 5.2 Removal of Existing Boiler From Common Vent System

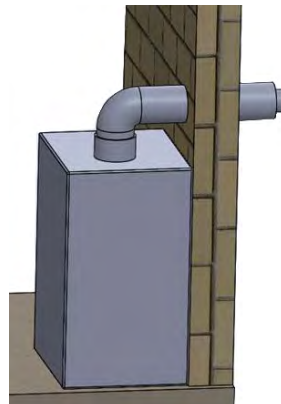
When existing boiler is removed from common venting system, common venting system is likely to be too large for proper venting of appliances remaining connected to it.

After removal of existing boiler, following steps shall be followed with each appliance remaining connected to common venting system placed in operation, while other appliances remaining connected to common venting system are not in operation:

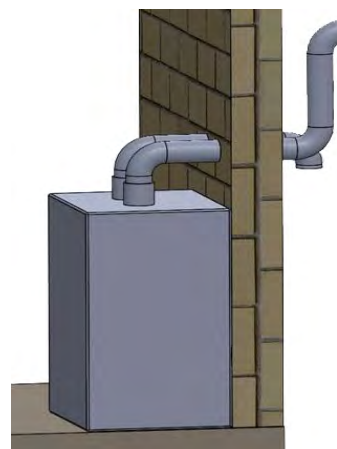
- Seal any unused openings in common venting system.
- Visually inspect venting system for proper size and horizontal pitch. Determine there is no blockage or restrictions, leakage, corrosion and other deficiencies which could cause an unsafe condition.
- When practical, close all building doors, windows, and all doors between space in which appliances remaining connected to common venting system are located and other spaces of building. Turn on clothes dryer and any appliance not connected to common venting system. Turn on exhaust fans, such as range hoods and bathroom exhaust so they will operate at maximum speed. Do not operate summer exhaust fan. Close fireplace dampers.
- Turn on appliance being inspected. Follow lighting instructions. Adjust thermostat so appliances will operate continuously.
- Test for spillage at draft hood relief opening after 5 minutes of main burner operation. Use flame of match or candle, smoke from cigarette, cigar or pipe.
- Determine each appliance remaining connected to common venting system properly vents when tested as outlined above. Then return doors, windows, exhaust fans and any other gas-burning appliance to their previous condition of use.
- Any improper operation of common venting system should be corrected so installation conforms with National Fuel Code, ANSI Z223.1/NFPA 54 and/or Natural Gas and Propane Installation Code, CAN/CSA B149.1. When re-sizing any portion of common venting system, common venting system should be re-sized to approach minimum size as determined using appropriate tables in Chapter 13 of the National Fuel Gas Code, ANSI Z223.1/NFPA 54 and/or Natural Gas and Propane Installation Code, CAN/CSA B149.1.

### 5.3 Definitions

1. **Coaxial piping** – Exhaust and air intake pipe have a common axis.



2. **Twin Pipe** – Exhaust and intake air are separate pipes, can be terminated using single wall terminals from the vent manufacturer or field built configuration using elbows or tees.





### **WARNING**

Manufacturer recommends this condensing boiler be vented with approved polypropylene venting material. Use only materials listed below for vent pipe, intake air pipe, and fittings. Failure to comply could result in death or serious injury.

### **WARNING**

- Covering non-metallic vent pipe and fittings with thermal insulation shall be prohibited.
- Use of cellular core PVC for venting flue gas could result in death, or serious injury.
- Coaxial venting shall be fastened with screws. Dual flue venting is NOT fastened with screws.

### **WARNING**

Do not use cellular core pipe. Only specified sized pipes are to be used. When using venting material other than boiler manufacturer's venting, note the correct installation procedure. Failure to follow these instructions could result in death, or serious injury.

### **WARNING**

Asphyxiation hazard! Pipe outdoor combustion air directly to boiler air connection. Ensure combustion air does not contain contaminants and is not drawn from an area likely to have contaminants. For example, never pipe combustion air from areas near swimming pools or laundry room exhaust vents. Contaminated combustion air will damage boiler resulting in death or serious injury.

### 5.4 Approved Venting Materials

Installation shall conform to requirements of authority having jurisdiction or in absence of such requirements:

- USA - National Fuel Gas Code, ANSI Z223.1/NFPA 54.
- Canada - Natural Gas and Propane Installation Code, CAN/CSA B149.1

1. Venting shall be properly supported.
2. Boiler shall not support any type of vent system.
3. All piping, glue, solvents, cleaners, fittings and components must conform to ASTM and ANSI standards. In Canada ULC S636 and in the USA UL 1738 schedule 40 CPVC are the only approved vent system to be used as an alternative to polypropylene venting for the exhaust pipe.
4. Manufacturer requires use of a mechanical fastener at every push-fit gasket connection when using a single wall polypropylene vent system.

### 5.5 Vent Termination

- Terminate combustion air and vent pipes with fittings or coaxial vent kit. Refer to venting illustrations for details.
- Separate vent terminal from air inlet terminal to prevent flue gas recirculation. If T-Terminal is used on flue pipe at sidewall, air inlet terminal shall be at least 36" or more away from vent terminal.
- Locate combustion air termination as far as possible from swimming pool, swimming pool pump house, and other sources of airborne chlorine.
- Locate combustion air and vent terminals as required by authority having jurisdiction.

### Approved Polypropylene Manufacturers

- \* Natalini
- \* DuraVent®
- \* Centrotherm
- \* Z-Flex®

Note: Maximum equivalent length may vary between manufacturers.

## VENT MATERIAL OPTIONS

(Maximum Equivalent Vent Length Shown)

75/100/115/125/150								
Vent Type	Vent Size	Vent Material	Intake (L1 <sup>***</sup> )		Exhaust (L2 <sup>***</sup> )		Combined Vent (L1+L2)	
			Max	Min	Max	Min	Max	Min
<b>Twin Pipe</b>	2" (60 mm)	Polypropylene	85 ft (25.9 m)	6 ft (1.8 m)	85 ft (25.9 m)	6 ft (1.8 m)	170 ft (51.8 m)	12 ft (3.6 m)
	3" (80 mm)	Polypropylene	49 ft (15 m)	6 ft (1.8 m)	147 ft (45 m)	6 ft (1.8 m)	196 ft (60 m)	12 ft (3.6 m)
		Flexible Exhaust* w/ Rigid 3" PP Intake						
CPVC** (PVC optional on intake ONLY)								
<b>Coaxial</b>	Vent Size	Material	Natalini		DuraVent		Centrotherm	
	Max	Min	Max	Min	Max	Min	Max	Min
	2"/4" (60 mm/100 mm)	Polypropylene	32.8 ft (10 m)	6 ft (1.8 m)	27.88 ft (8.5 m)	6 ft (1.8 m)	24.60 ft (8.5 m)	6 ft (1.8 m)
	3"/5" (80 mm/128 mm)							

\*For vertical runs only  
 \*\* In Canada ULC S636 and in the USA UL1738 schedule 40 CPVC are the only approved Vent Material to be used as an alternative to Polypropylene venting for the exhaust pipe.  
 \*\*\* See Figures 5-8 to 5-10 for L1 & L2 details.

165/205								
Vent Type	Vent Size	Vent Material	Intake (L1 <sup>***</sup> )		Exhaust (L2 <sup>***</sup> )		Combined Vent (L1+L2)	
			Max	Min	Max	Min	Max	Min
<b>Twin Pipe</b>	2" (60 mm)	Polypropylene	85 ft (25.9 m)	6 ft (1.8 m)	85 ft (25.9 m)	6 ft (1.8 m)	170 ft (51.8 m)	12 ft (3.6 m)
	3" (80 mm)	Polypropylene	100 ft (30.5 m)	6 ft (1.8 m)	100 ft (30.5 m)	6 ft (1.8 m)	200 ft (60.9 m)	12 ft (3.6 m)
		Flexible Exhaust* w/ Rigid 3" PP Intake						
CPVC** (PVC optional on intake ONLY)								
<b>Coaxial</b>	Vent Size	Material	Natalini		DuraVent		Centrotherm	
	Max	Min	Max	Min	Max	Min	Max	Min
	2"/4" (60 mm/100 mm)	Polypropylene						
	3"/5" (80 mm/128 mm)		32.8 ft (10 m)	6 ft (1.8 m)	32.8 ft (10 m)	6 ft (1.8 m)	32.8 ft (10 m)	6 ft (1.8 m)

\*For vertical runs only  
 \*\* In Canada ULC S636 and in the USA UL1738 schedule 40 CPVC are the only approved Vent Material to be used as an alternative to Polypropylene venting for the exhaust pipe.  
 \*\*\* See Figures 5-8 to 5-10 for L1 & L2 details.

5.6 Coaxial Venting Instructions

Maximum equivalent flue lengths for Coaxial venting are:

Coaxial Pipe Vent Lengths (Includes First Elbow And Termination)			
Boiler Size	75/100/115 125/150	165/205	ALL
Vent Size	4"/2" [100mm/60mm]	5"/3" [128mm/80mm]	ALL
	Maximum		Minimum
Natalini	32.8 ft [10m]	32.8 ft [10m]	6 ft. [1.8m]
DuraVent	27.88 ft [8.5m]		
Centrotherm	24.60 ft [7.5m]		
Z-Flex/Z-Dens	24.60 ft [7.5m]		

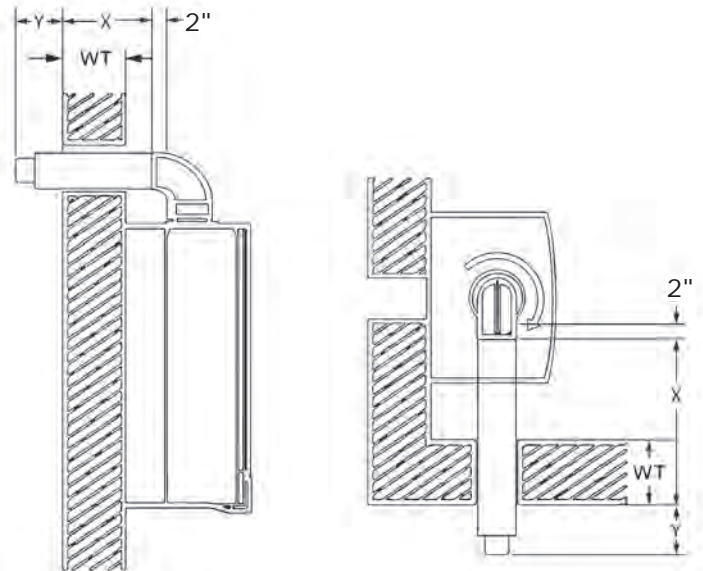
Coaxial Elbows - Equivalent length	
4"/2" [100 mm/60 mm]	
45°	1.64 ft. [0.5 m]
90°	3.28 ft. [1.0 m]
5" / 3" [128 mm/80 mm]	
45°	1.64 ft. [0.5 m]
90°	3.28 ft. [1.0 m]
Coaxial Termination - Equivalent length 3 ft (0.9m)	

**NOTE:** Coaxial venting can run horizontal or vertical.

- Connect flue elbow to top of boiler and adjust direction of elbow to desired orientation (rear, right or left).
- Measure distance from outside wall face to elbow, this dimension will be known as "X", add distance "Y" + 2" (60 mm) to "X" this is the total dimension of the vents. See Figure 5-2.
- Mark dimension from above on outer aluminum intake vent. Measure length of waste material, and transfer dimension to inner grey flue pipe.
- Remove waste from both vents (flue and air). Verify cut ends are square and free from burrs. Insert flue back into intake air vent and pass them through hole in wall.
- Check all measurements before cutting. Clearance to combustible materials is zero when using coaxial vent system.
- After installing venting use calibrated analyzer to verify there is no recirculation of combustion.
- Ensure Horizontal termination is positioned with fresh air slots on the bottom.

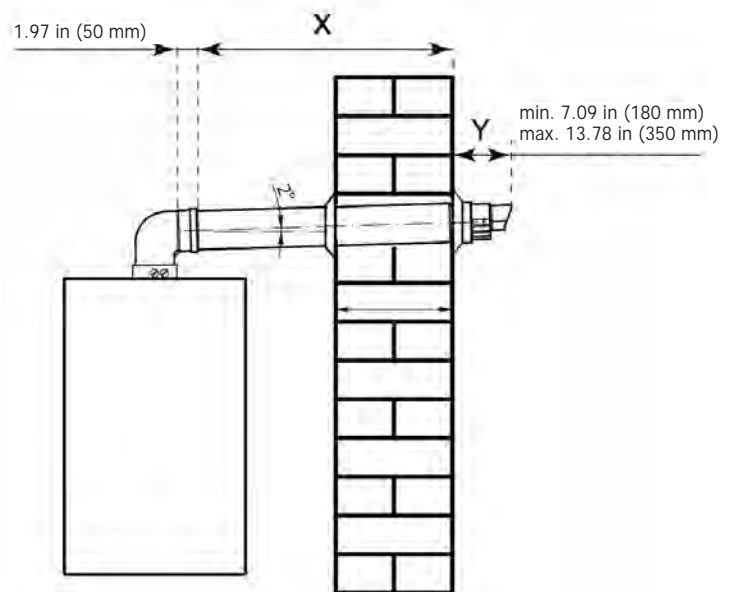
**⚠ WARNING**

Asphyxiation hazard! Before securing screws ensure the pipe has been pushed in a minimum of 1-3/4" (45 mm) into the gasket end of the other pipe. Failure to follow these instructions could result in death or serious injury.



WT = Wall Thickness

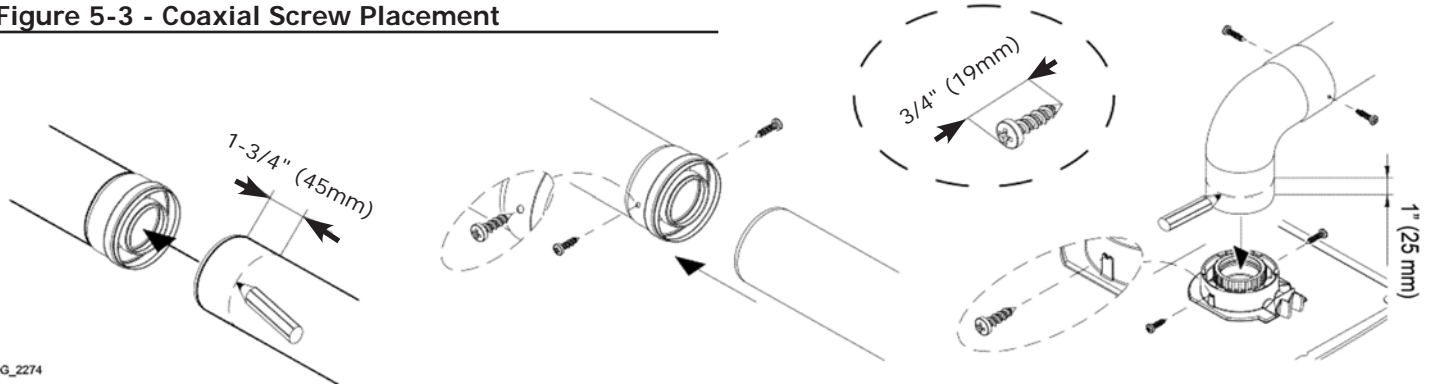
Note: 2" is insertion depth of straight pipe to elbow.



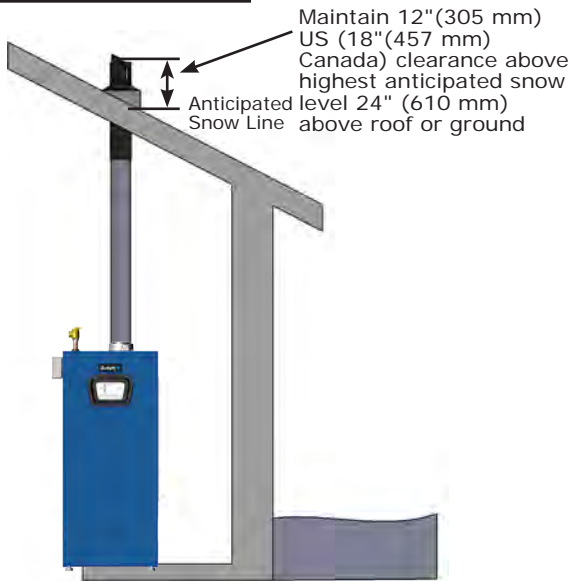
**5.7 Coaxial Vent Screw Placement - See Figure 5-3**

Two (2) screws shall be fastened through the outer intake pipe behind the gaskets at equal distances, approximately 180° apart. Note the screws used must be no larger than No. 8-3/4 sheet metal screws and must be zinc coated.

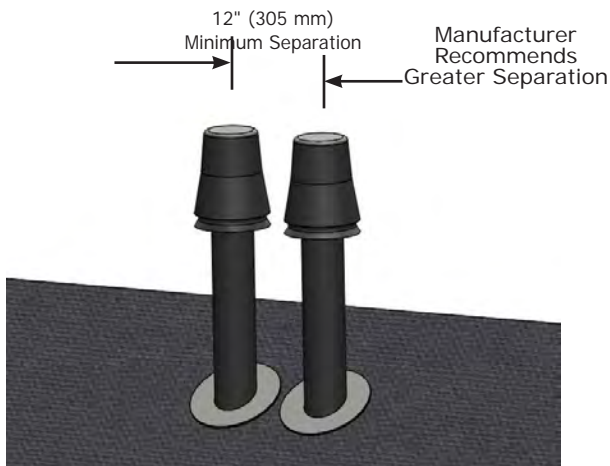
**Figure 5-3 - Coaxial Screw Placement**



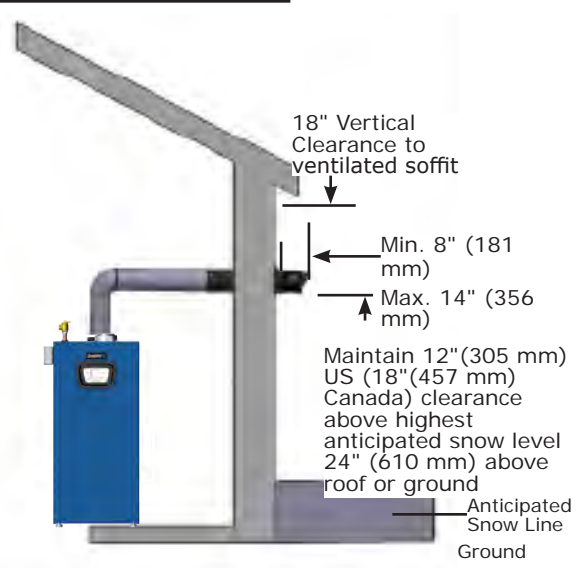
**FIGURE 5-4 Roof Mount Coaxial Venting  
CAN BE USED ON ALL SIZES**



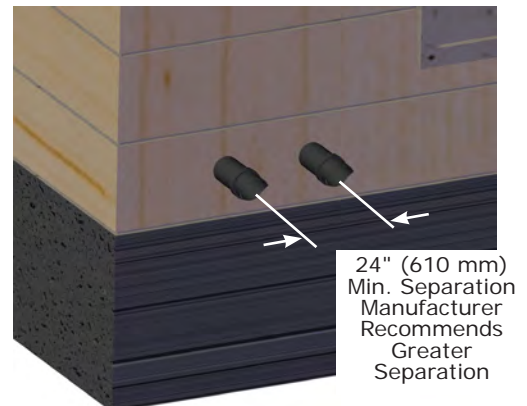
**FIGURE 5-5 - Coaxial Vertical Exhaust - *Multiple Appliances*  
CAN BE USED ON ALL SIZES**



**FIGURE 5-6 Side Wall Coaxial Venting  
CAN BE USED ON ALL SIZES**



**FIGURE 5-7 - Coaxial Horizontal Exhaust - *Multiple Appliances*  
CAN BE USED ON ALL SIZES**



## 5 - COMBUSTION AIR AND VENT PIPING

### ⚠ WARNING

Asphyxiation hazard! Improper installation could result in death or serious injury. Read Twin Pipe Installation Instructions completely and understand all requirements before beginning installation.

#### 5.8 Twin Pipe Systems

Twin pipe venting allows exhaust flue and intake flue to be separated from each other.

Fig 5-8: Horizontal termination required for exhaust pipe, fresh air inlet can use horizontal termination or raw end of straight section of pipe.

PVC can be used on **intake only** on twin pipe applications.

##### A. Twin Pipe CPVC System

CPVC is approved for boiler exhaust. CPVC or PVC are both approved for air intake.

To transition from Coaxial at the top of the boiler to Twin Pipe CPVC/PVC a kit is available. See Figure 5-14.

##### B. Twin Pipe Polypropylene System

Single wall polypropylene is used for both exhaust and air intake piping. PVC can be used on **intake only** on twin pipe applications.

Use the appropriate transition kit to change from polypropylene to PVC. To transition from Coaxial, at the top of the boiler to Twin Pipe polypropylene venting an adapter kit is available. See Figure 5-13.

##### C. Twin Pipe Separated Flue

Exhaust and combustion air intake are not located in same general location. 5-8, 5-9, 5-10, 5-21, 5-22.

##### D. Twin Pipe - Common Atmospheric Zone Termination

Exhaust and combustion air intake are located in same general location and are of equal length. See Figures 5-23 through 5-32.

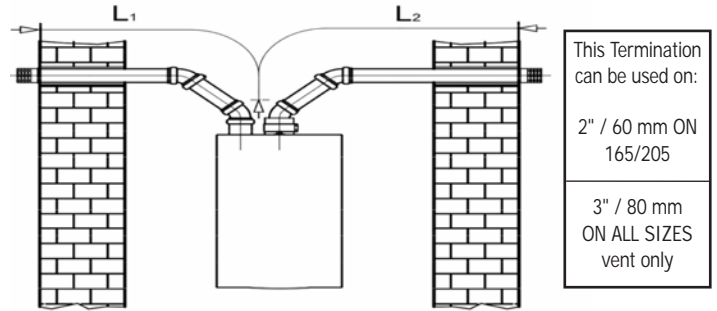
Twin Pipe Maximum Vent Lengths (Includes first elbow and termination)						
Boiler		75/100/115/125/150		165/205		All
Vent Size		3" [80 mm]	2" [60 mm]	3" [80 mm]	2" [60 mm]	All
Maximum						Minimum
Intake Vent	L1	49 ft [15m]	85 ft [25.9m]	100 ft [30.5m]	85 ft [25.9m]	6 ft [1.8 m]
Exhaust Vent	L2	147 ft [45m]				
Combined Vent	L1+L2	196 ft [60m]	170 ft [51.8m]	200 ft [60.9m]	170 ft [51.8m]	12 ft. [3.6 m]

#### Single Wall Elbows - Equivalent Length

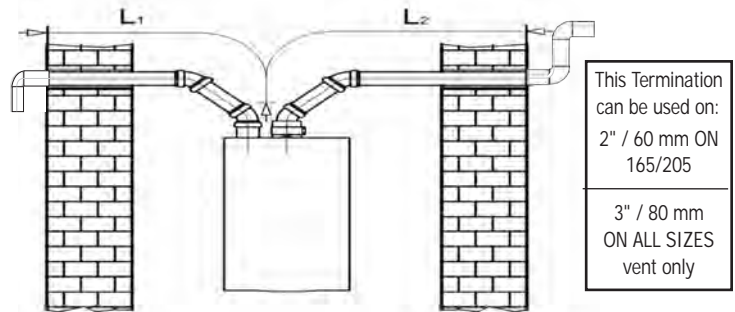
	3" (80 mm)	2" (60 mm)
45° bend	0.82 ft [0.25 m]	3 ft [0.91 m]
90° bend	1.64 ft [0.50 m]	5 ft [1.5 m]

**NOTE:** Two pipe can be installed horizontally or vertically.

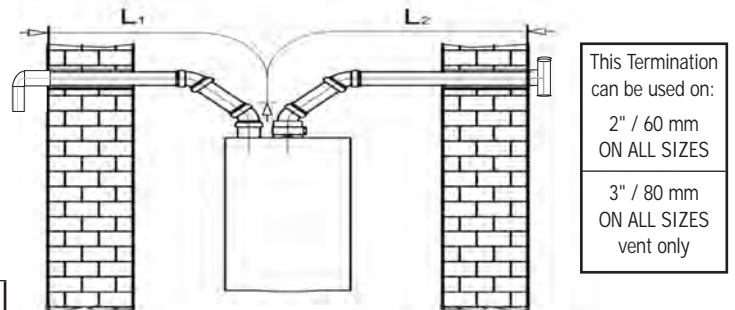
**FIGURE 5-8 - 2"/60 mm & 3"/80 mm Twin Pipe Separated Horizontal Flue Termination**



**FIGURE 5-9 - 2"/60 mm & 3"/80 mm Twin Pipe Separated Horizontal Flue Termination**



**FIGURE 5-10 - 2"/60 mm & 3"/80 mm Twin Pipe Separated Horizontal Flue Termination With Tee On Exhaust - CAN BE USED ON ALL SIZES**



**Grade, Snow & Ice**

Maintain 12" (305 mm) US, 18" (457 mm) Canada clearance above highest anticipated snow level, 24" (610 mm) above roof.

Avoid locations where snow may drift and block vent and combustion air. Ice or snow may cause boiler to shut down if vent or combustion air becomes obstructed.

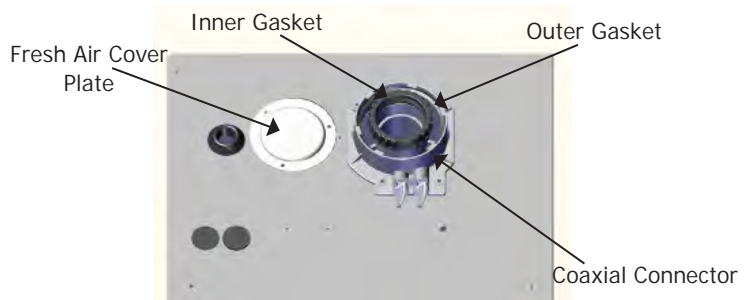


**5.9 Twin Pipe Polypropylene Adapter Kit Installation for 75/100/110/125/150 Boilers**

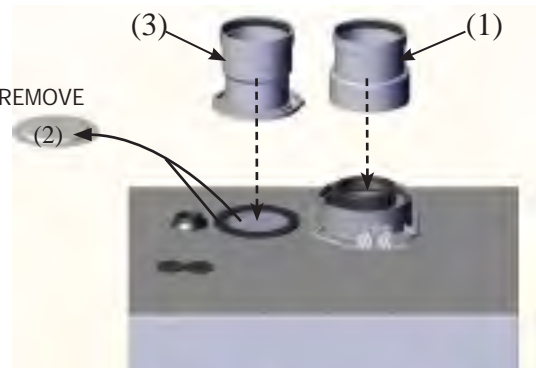
[See Figures 5-11,5-12 & 5-13]

1. Inspect Coaxial Connector on top of boiler. Confirm the factory installed inner and outer gaskets are in place.
2. Insert the Flue adapter (1) into the Coax connector, push down firmly to fully seat it.
3. Remove (3) screws securing the Fresh Air cover plate (2).
4. Remove gasket and discard.
5. Install Fresh Air inlet adapter and new gasket (3), secure with 3 screws.

**Figure 5-11 - Twin Pipe Adapter Kit  
75-150 Model Boilers**



**Figure 5-12 - Twin Pipe CPVC Adapter Kit  
75-150 Model Boilers**



**Figure 5-13 - Twin Pipe Polypropylene Adapter Kit  
75-150 Model Boilers**

**5.10 Twin Pipe CPVC Adapter Kit Installation for 75/100/110/125/150 Boilers**

[See Figures 5-13 thru 5-14]

1. Inspect Coaxial Connector on top of boiler. Confirm the factory installed inner and outer gaskets are in place.
2. Insert the Flue adapter (1) into the Coax connector, push down firmly to fully seat it.
3. Remove (3) screws securing the Fresh Air cover plate (2).
4. Remove the gasket and discard.
5. Install the Fresh Air inlet adapter and new gasket (3), secure with 3 screws.
6. Insert CPVC adapters into Polypropylene flue adapters, firmly seat.



**Figure 5-14 - Twin Pipe CPVC Adapter Kit  
75-150 Model Boilers**



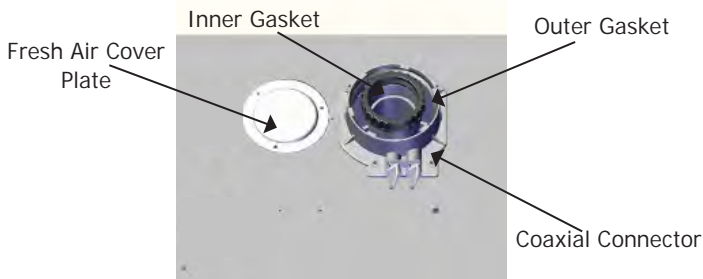


**5.11 Twin Pipe Polypropylene Adapter Kit Installation  
165/205 Boilers**

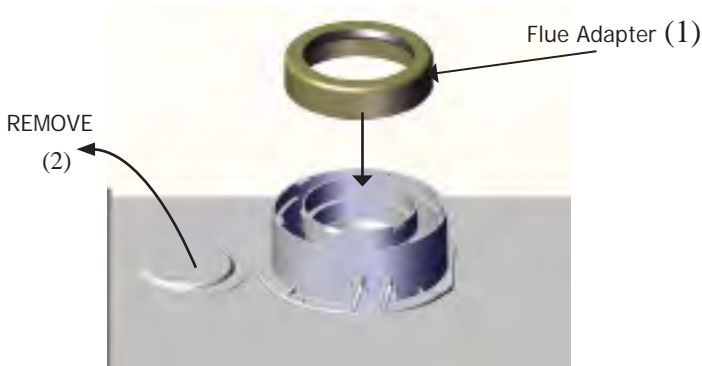
[See Figures 5-15 through 5-17]

1. Inspect Coaxial Connector on top of boiler. Confirm the factory installed inner and outer gaskets are in place.
2. Insert the Flue adapter (1) into the Coax connector, push down firmly to fully seat it.
3. Remove (3) screws securing the Fresh Air cover plate (2).
4. Remove the gasket and discard.
5. Install the Fresh Air inlet adapter and new gasket (3), secure with 3 screws.

**Figure 5-15 - Coaxial to Twin Pipe Adapter Kit  
165-205 Model Boilers**



**Figure 5-16 - Coaxial to Twin Pipe Adapter Kit  
165-205 Model Boilers**



**Figure 5-17 - Twin Pipe Polypropylene Adapter Kit  
165-205 Model Boilers**

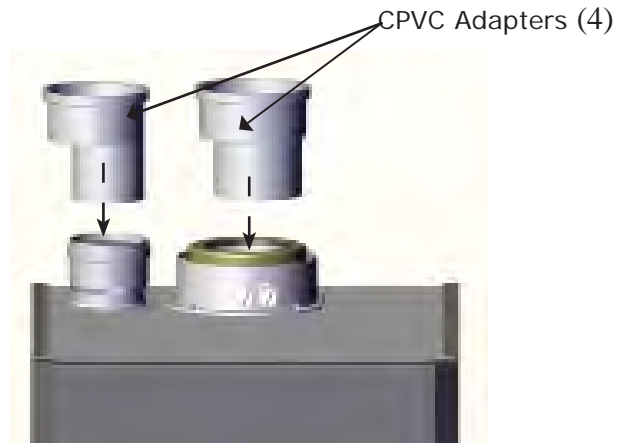


**5.12 Twin Pipe CPVC Adapter Kit Installation  
165/205 Boilers**

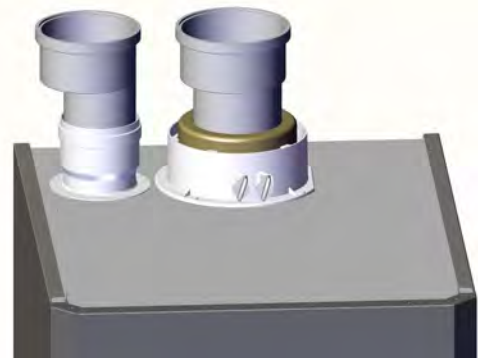
[See Figures 5-11, 5-12, 5-17, 5-18 & 5-19]

1. Inspect Coaxial Connector on top of boiler. Confirm the factory installed inner and outer gaskets are in place.
2. Insert the Flue adapter (1) into the Coax connector, push down firmly to fully seat it. Figure 5-16
3. Remove (3) screws securing the Fresh Air cover plate (2). Figure 5-17
4. Remove the gasket and discard.
5. Install the Fresh Air inlet adapter and new gasket (3), secure with 3 screws. Figure 5-17.
6. Insert CPVC adapters into polypropylene flue adapters and firmly seat. (4) Figures 5-18 & 5-19

**Figure 5-18 - Twin Pipe CPVC Adapter Kit  
165-205 Model Boilers**



**Figure 5-19 - Twin Pipe CPVC Adapter Kit  
165-205 Model Boilers**



**⚠ WARNING**

Asphyxiation hazard! Improper installation could result in death or serious injury. Read Twin Pipe Installation Instructions completely and understand all requirements before beginning installation.

**NOTICE**

Venting manufacturer's use a device to secure single wall twin pipe polypropylene vent pieces to each other. Proper application of the securing mechanism is necessary for any use of twin pipe polypropylene venting on exhaust or air intake. Securing mechanism is for indoor use only and should not be used in outdoor applications. Follow venting manufacturer's instructions for applying the securing mechanism on twin pipe polypropylene venting.

Figure 5-20 - Natalini Clamp

**5.13 Securing Twin Pipe Polypropylene Venting**

**Example for Natalini venting system. See Figure 5-20**

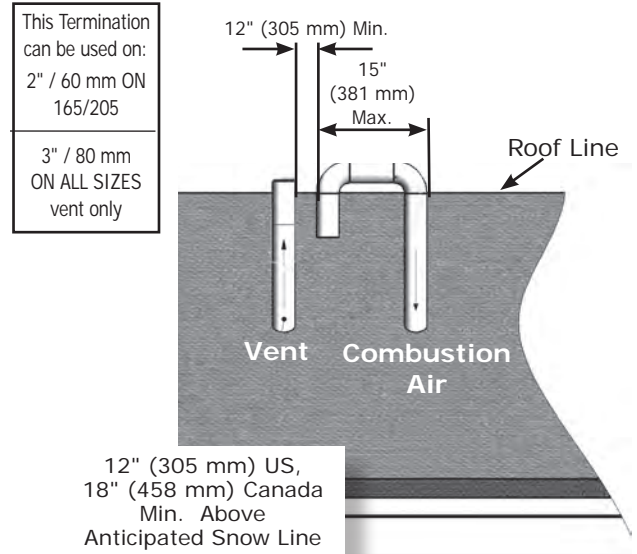
(For other venting system suppliers see their instructions.)

1. Place clamp so etched "UP" is facing up.
2. Open clamp slightly by separating circular areas from each other.
3. Slide male end of first pipe through open clamp so the shoulder of the female end of the pipe stops the clamp from sliding off the pipe.
4. Insert the male end of the second pipe into the clamp on the "up" etched side. Force the two pipes together.
5. Verify the two pipes are secure together with clamp in place.

## 5 - COMBUSTION AIR AND VENT PIPING

<b>Roof Terminations</b>	<ul style="list-style-type: none"> <li>• 12" (305 mm) Min. horizontal separation between combustion air intake and vent of same appliance.</li> <li>• 12" (305 mm) Min. 84" (2.2 m) Max. vertical separation between combustion air intake and vent of different appliances.</li> <li>• 15" (381 mm) Max. horizontal length of vent.</li> <li>• Min. vent/intake between different appliances 12" (305 mm).</li> <li>• Max. allowable total vertical vent length with outside exposure is 10 ft. (3.05 m).</li> <li>• Abandoned unused masonry chimney may be used as chase-way for combustion air and vent. Both combustion air and vent pipe must exit above top of chimney with clearances as shown in Figure 5-14.</li> </ul>
--------------------------	---

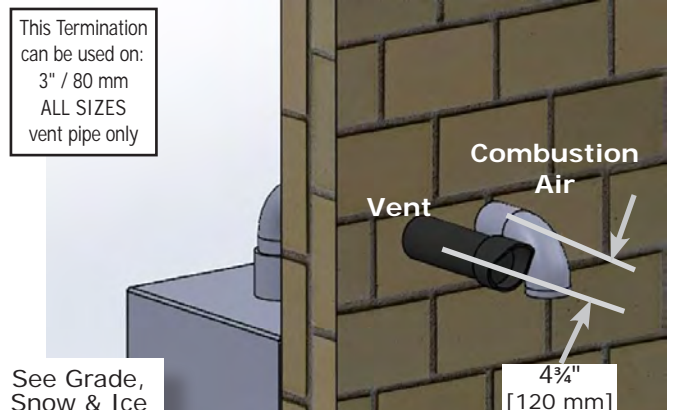
**FIGURE 5-23 - (2" / 60 mm & 3" / 80 mm) Twin Pipe Roof Vent CAN BE USED ON ALL SIZES**



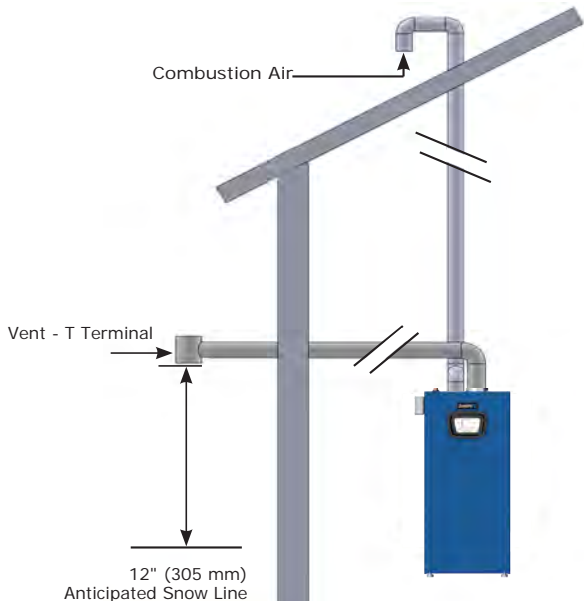
**FIGURE 5-21 - Twin Pipe on Roof Combustion Air On Sidewall CAN BE USED ON ALL SIZES**



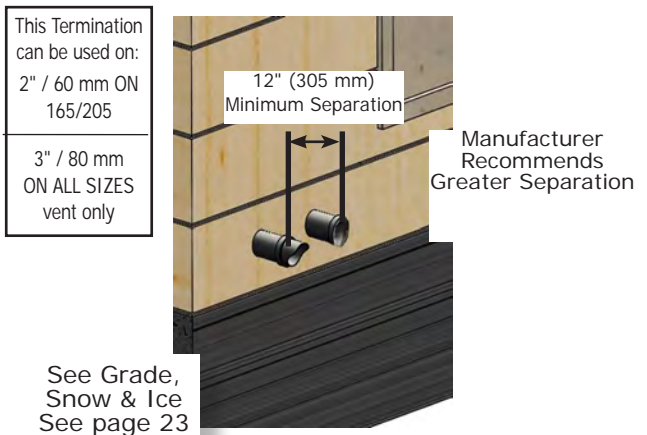
**FIGURE 5-24 - (3" / 80 mm ONLY) Single Wall Exhaust Kit and Air Intake Minimum Distance Center to Center**



**FIGURE 5-22 - Twin Pipe Flue On Sidewall, Combustion Air On Roof CAN BE USED ON ALL SIZES**

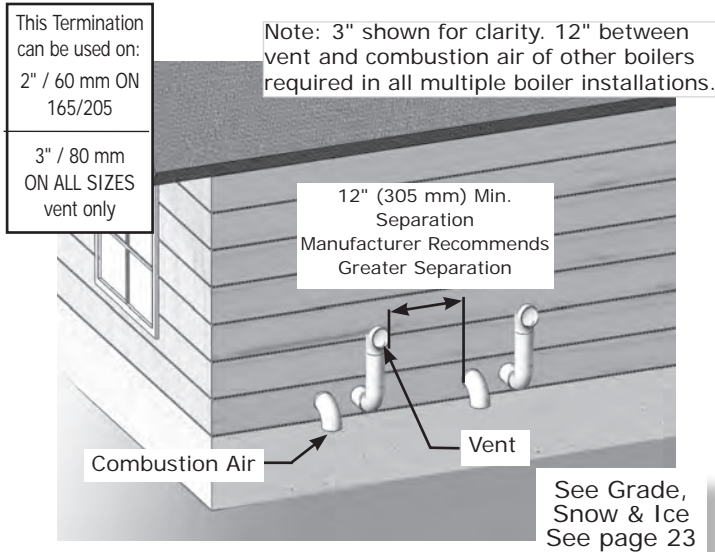


**FIGURE 5-25 - Horizontal Twin Pipe, Exhaust and Intake**

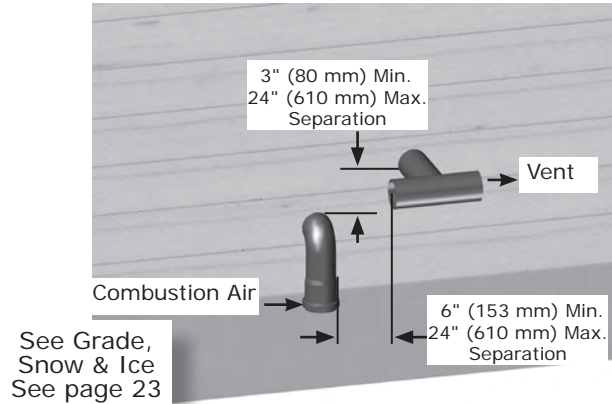


## 5 - COMBUSTION AIR AND VENT PIPING

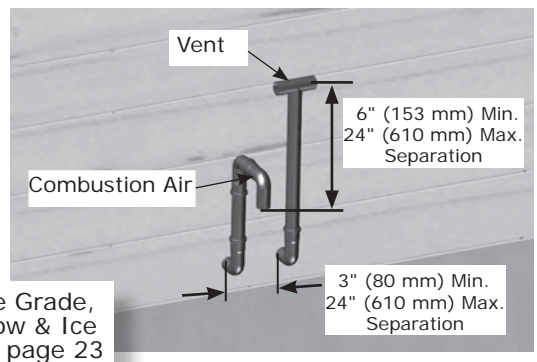
**FIGURE 5-26 - Twin Pipe Side Wall Vent (Multiple Appliances)**



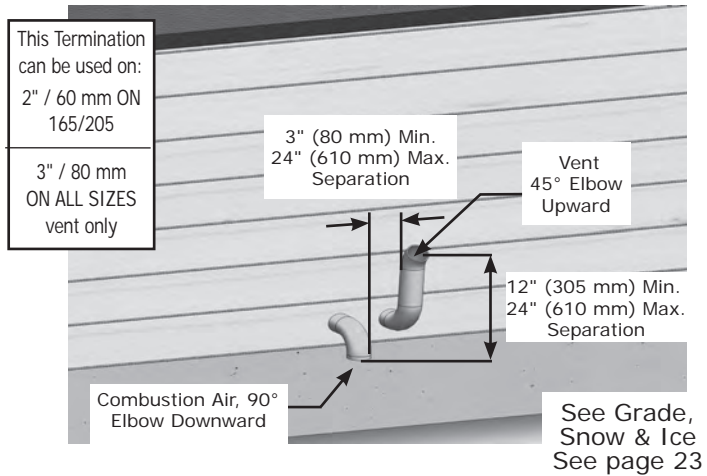
**FIGURE 5-29 - (2" / 60 mm ONLY) Vent Pipe with T CAN BE USED ON ALL SIZES**



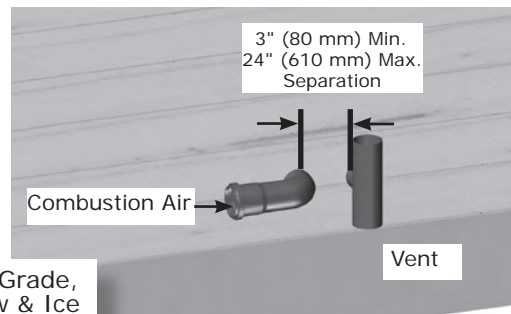
**FIGURE 5-30 - (2" / 60 mm ONLY) Vent Pipe with T CAN BE USED ON ALL SIZES**



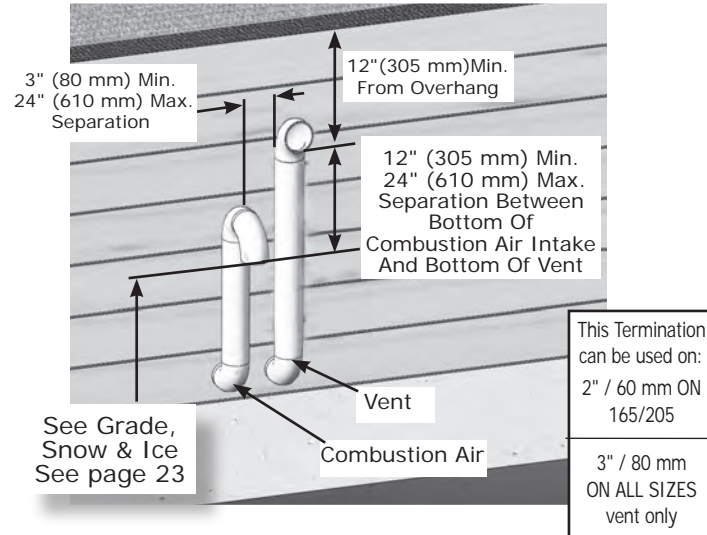
**FIGURE 5-27 - (3" / 80 mm ONLY) Twin Pipe Side Wall with 45° Vent**



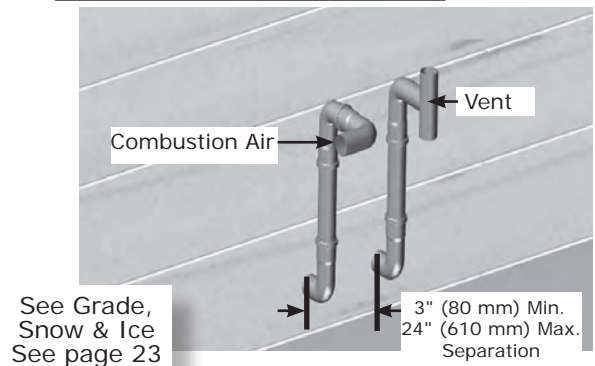
**FIGURE 5-31 - (2" / 60 mm ONLY) Twin Pipe Side Wall Vent CAN BE USED ON ALL SIZES**



**FIGURE 5-28 - (3" / 80 mm ONLY) Twin Pipe Side Wall Vent**



**FIGURE 5-32- (2" / 60 mm ONLY) Twin Pipe Side Wall Vent CAN BE USED ON ALL SIZES**





## 5 - COMBUSTION AIR AND VENT PIPING

### 5.14 (3" / 80 mm Only) Flexible Vent System

**FIGURE 5-33 - (3" / 80 mm Only) Flexible Venting System CAN BE USED ON ALL SIZES**

Flexible Pipe Minimum & Maximum Vent Lengths					
3" [80 mm] Diameter Pipe		75/100/115/125/150		165/205	
		Min	Max	Min	Max
Natalini	Exhaust	6 ft [1.8 m]	75 ft [22.8 m]	6 ft [1.8 m]	50 ft [15.2 m]
	Intake	6 ft [1.8 m]	50 ft [15.2 m]	6 ft [1.8 m]	50 ft [15.2 m]
DuraVent®	Exhaust	6 ft [1.8 m]	82 ft [24.9 m]	6 ft [1.8 m]	50 ft [15.2 m]
	Intake	6 ft [1.8 m]	50 ft [15.2 m]	6 ft [1.8 m]	50 ft [15.2 m]
Centrotherm	Exhaust	6 ft [1.8 m]	52 ft [15.8 m]	6 ft [1.8 m]	50 ft [15.2 m]
	Intake	6 ft [1.8 m]	50 ft [15.2 m]	6 ft [1.8 m]	50 ft [15.2 m]
Z-Dens	Exhaust	NA		6 ft [1.8 m]	50 ft [15.2 m]
	Intake	NA		6 ft [1.8 m]	50 ft [15.2 m]

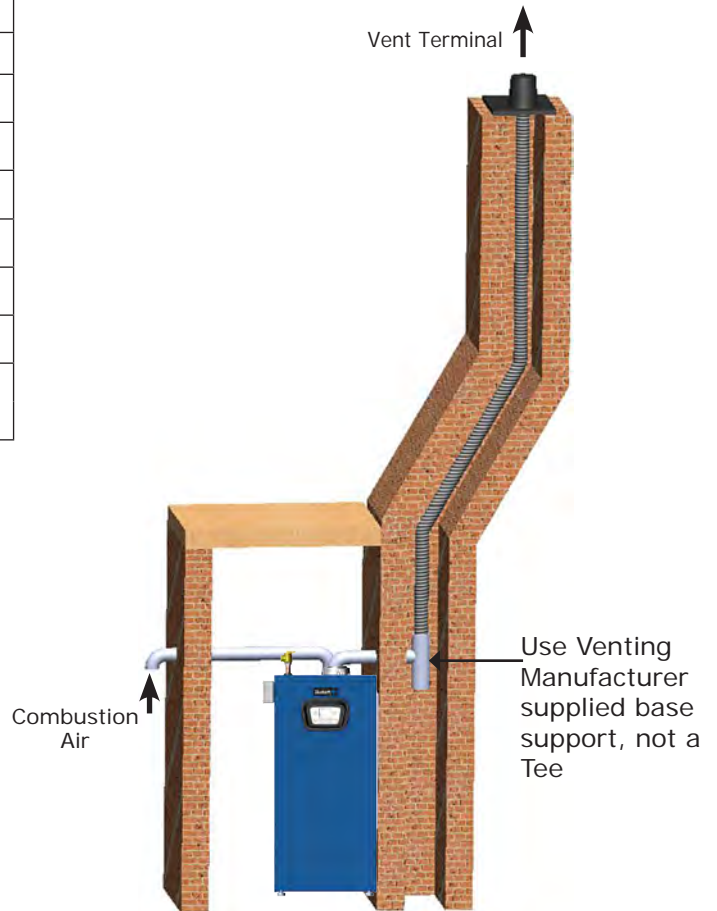
### Single Wall Elbows - Equivalent Length

Vent Dia.	3" [80 mm]
45° bend	0.82 ft [0.25 m]
90° bend	1.64 ft [0.50 m]



Flexible vent systems shall only be run vertical. Horizontal runs before adapting to flexible must be rigid pipe.

- Follow venting manufacturer's instructions on assembly and clearances to maintain.
- Maximum vent lengths based on equivalent straight runs only. Include rigid pipe and fittings in overall equivalent length calculations.
- Flexible venting installations use single wall polypropylene to pass flue gasses to base of chimney, then flexible venting to get them to termination at the top.
- Combustion air is not supplied through masonry chimney. Combustion air must be from outside using 3" [80 mm] single wall polypropylene.
- Position boiler to use minimum of rigid single wall polypropylene venting to the chimney.
- Avoid sharp bends in flexible venting.





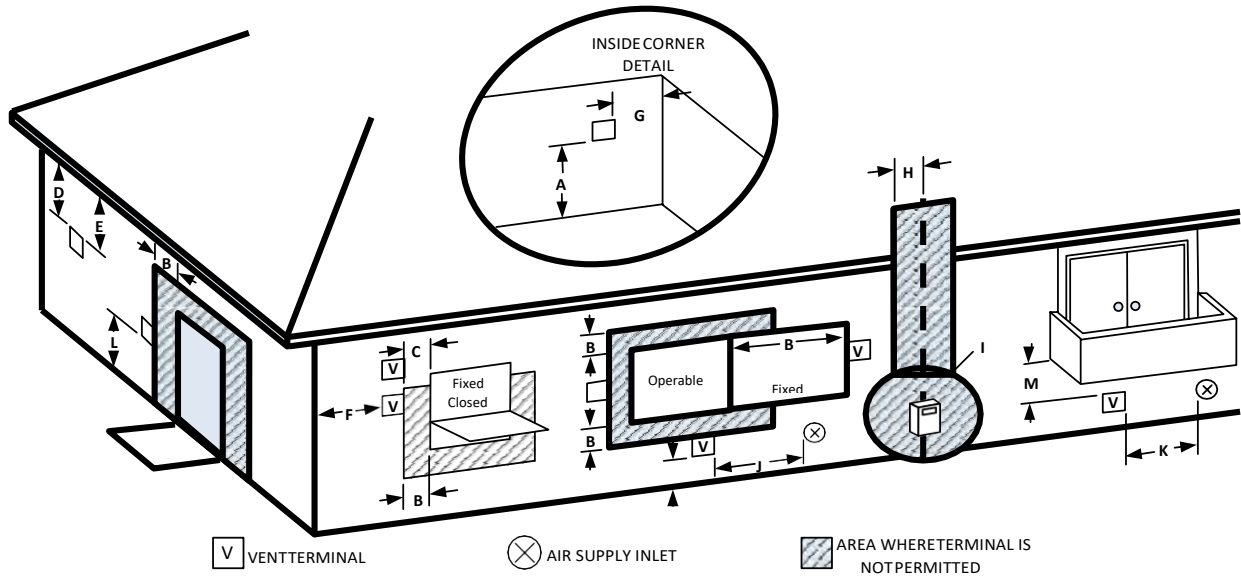
## 5 - COMBUSTION AIR AND VENT PIPING

**FIGURE 5-34 - Flue Terminal Location**

All vent pipe and combustion air pipe and fittings shall comply with the following:

Use only manufacturer approved venting materials or venting materials primer and glue approved to: ULC S636 in Canada, or UL 1738 in the U.S.

Materials used in the U.S. shall comply with Authority having jurisdiction and in absence of such with: ANSI/ASTM D1785, ANSI/ASTM F441, ANSI/ASTM F493.

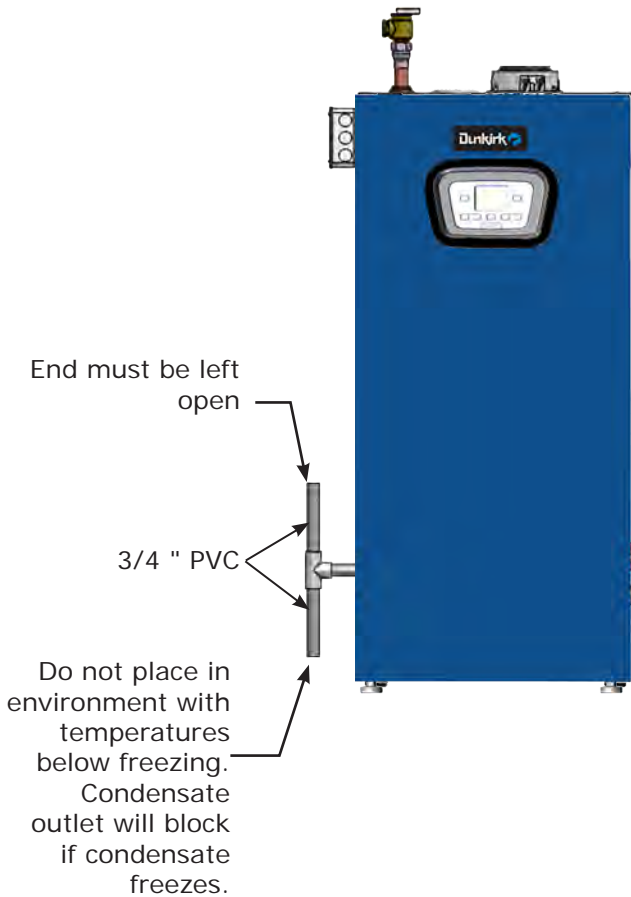


**Vent Termination Minimum Clearances**

		US Installations	Canadian Installations
<b>A</b>	Clearance above grade, veranda, porch, deck, or balcony	12" (305 mm)	12" (305 mm)
<b>B</b>	Clearance to window or door that may be opened	12" (305 mm)	3 ft. (0.9 m)
<b>C</b>	Clearance to permanently closed window	*12" (305 mm)	*12" (305 mm)
<b>D</b>	Vertical Clearance to ventilated soffit located above the terminal within a horizontal distance of 2 feet (610 mm) from the center line of the terminal	18" (457 mm)	18" (457 mm)
<b>E</b>	Clearance to unventilated soffit	18" (457 mm)	18" (457 mm)
<b>F</b>	Clearance to outside corner	9" (229 mm)	9" (229 mm)
<b>G</b>	Clearance to inside corner	36" (456 mm)	36" (456 mm)
<b>H</b>	Clearance to each side of center line extended above meter/regulator assembly	3 ft. (0.9 m) within a height of 15 ft. (4.5 m) above the meter/regulator assembly	3 ft. (0.9 m)
<b>I</b>	Clearance to service regulator vent outlet	3 ft. (0.9 m)	3 ft. (0.9 m)
<b>J</b>	Clearance to non-mechanical air supply inlet to building or the combustion air inlet to any other appliance	12" (305 mm)	3 ft. (0.9 m)
<b>K</b>	Clearance to mechanical air supply inlet	*3 ft. (0.9 m)	6 ft. (1.8 m)
<b>L</b>	Clearance above paved sidewalk or paved driveway located on public property	*7 ft. (2.1 m)	7 ft. (2.1 m) †
† A vent shall not terminate directly above a sidewalk or paved driveway that is located between two single family dwellings and serves both dwellings.		*For clearances not specified in ANSI Z223.1/NFPA 54 or CSA B149.1, clearance will be in accordance with local installation codes and the requirements of the gas supplier and these installation instructions.	

**Note:** Local Codes or Regulations may require different clearances. Flue terminal must be exposed to external air and position must allow the free passage of air across it at all times. In certain weather conditions the terminal may emit a plume of steam. Avoid positioning terminal where this may cause a nuisance.

FIGURE 5-35 - Condensate Drain



5.15 Condensate Piping

- Use materials acceptable to authority having jurisdiction. In absence of such authority:
  - USA - PVC or CPVC per ASTM D1785/D2845 Cement or primer per ASME D2564 or F493.
  - Canada - CSA or ULC certified PVC/CPVC pipe, fittings and cement.
- No external trap needed.
- Connect condensate hose, hose clamps, and coupling to boiler drain trap as shown in figure 5-35.
- Connect condensate piping to 3/4" PVC as shown.
- Slope condensate drain pipe minimum 1/4" per foot (21 mm/m) away from boiler.
- Support condensate pipe to eliminate any sages.
- Use field source condensate pump, designated for use with condensing boiler, if boiler located below disposal point.
- Condensate pump should have overflow switch. Condensate from Boiler is slightly acidic and may cause property damage if overflow.
- Field source condensate neutralizing kit as required by authority having jurisdiction or for environmentally friendly condensate disposal.

**NOTICE**

Manufacturer requires an air vent be used to prevent condensate line vacuum lock.

### ! WARNING

- Poison hazard. Ethylene glycol is toxic. Do not use ethylene glycol.
- Never use automotive or standard glycol antifreeze, even ethylene glycol made for hydronic systems.
- Ethylene glycol can attack gaskets and seals used in hydronic systems.
- Do not use petroleum based cleaning or sealing compounds boiler system.
- Do not fill boiler or boiler system with softened water.
- Use only inhibited propylene glycol solutions certified by fluid manufacturer as acceptable for use with closed water heating system.
- Thoroughly clean and flush any system that used glycol before installing new Boiler.
- Provide user with Material Safety Data Sheet (MSDS) on fluid used.

**Note** Boiler rated at 50 psig (3.45 kPa) maximum allowable working pressure. Boiler provided with 30 psig (2.06 kPa) safety relief valve.

**Note** System pressure above 43 psi [2.96 bar] **WILL** result in boiler shutting down.

### 6.1 General

- Primary/Secondary piping required.
- Install piping in accordance with authority having jurisdiction.
- Support system piping and safety relief valve discharge piping. Boiler's internal piping can be damaged if subjected to excessive weight.

### NOTICE

The intended use of the internal heat exchanger pump is a boiler loop. Do not use as a primary system pump.

- Size central heating pump (and domestic hot water pump, if used) for system requirements only. Internal heat exchanger pump compensates for pressure drop through boiler internal piping and heat exchanger.
- Thoroughly clean and flush system before connecting to boiler.
- If oil is present in system water, use approved detergent to wash system.
- It is necessary to semi-annually check the water quality of central heating systems.

- Manufacturer recommends installation of magnetic dirt separator in the hydronic system where there are cast iron or steel components, or where the previous boiler was a cast iron heat exchanger. The abrasive, extremely fine sediment is difficult to remove and can deposit onto heat exchange surfaces and accumulate in pump cavities causing reduced efficiency and premature wear.
- Flush system to remove any solid objects such as metal chips, fibers, or Teflon tape, etc.
- Flush system until water runs clean and piping is free of sediment.
- Use purge valve to flush zoned systems, each zone separately. If purge valves and isolation valves are not installed, install them to properly clean the system.
- When purging installations that include standing iron radiators and systems with manual vents at high points, start with nearest manual air vent. Open the vent until water flows out, then close vent. Repeat this procedure, working toward furthest air vent.
- Install a basket strainer if large amounts of sediment is present. Keep basket clear of sediment build up.
- Ensure piping in the heating system has an oxygen barrier.

**Note** Do not expose boiler and condensate piping to freezing temperatures.

### 6.2 Special Conditions

- System piping exposed to freezing conditions: Use inhibited propylene glycol solutions certified by fluid manufacturer for use with closed water heating system. Do not use automotive or ethylene glycol.
- Boiler installed above radiation level (or as required by authority having jurisdiction). Integral low water pressure switch is provided in boiler.
- Boiler used in connection with refrigeration system. Install piping in parallel with boiler, with appropriate valves to prevent chilled medium from entering boiler.
- System piping connected to heating coils located in air handling unit exposed to refrigerated air circulation. Install flow control valves or other automatic means to prevent gravity circulation of boiler water during cooling cycle.
- Boiler used to provide heat to fan coil unit, which also contains a refrigeration coil, precautions should be taken to prevent the hot water coil from freezing. Consider items such as a freeze sensor on the hot water coil and/or low ambient controls on the air conditioning unit. It is manufacturer recommended to install a drip pan whenever there is a risk of damage to the area below a fan coil as a result of a water leak.

### ⚠ WARNING

Burn and scald hazard. Safety relief valve could discharge steam or hot water during operation. Use pipe suitable for temperatures of 375°F (191°C) or greater. DO NOT use plastic pipe. Install discharge piping per these instructions.

#### Note

When installing safety relief valve it must be installed in a vertical position with spindle at top.

### 6.3 Safety Relief Valve and Air Vent

- Install safety relief valve using pipe fitting provided with boiler. See Figure 6-1.
- Install safety relief valve with spindle in vertical position.
- Do not install shutoff valve between boiler and safety relief valve.
- Install discharge piping from safety relief valve. Do not use plastic pipe.
- Use ¾" or larger pipe.
- Use pipe suitable for temperatures of 375°F (191°C) or greater. Do not use plastic pipe on safety relief valve.
- Individual boiler discharge piping shall be independent of other discharge piping.
- Size and arrange discharge piping to avoid reducing safety relief valve relieving capacity below minimum relief valve capacity stated on rating plate.
- Run pipe as short and straight as possible to location protecting user from scalding and properly drain piping.
- Install union, if used, close to safety relief valve outlet.
- Install elbow(s), if used, close to safety relief valve outlet and downstream of union (if used).
- Terminate pipe with plain end (not threaded).

### 6.4 Trim Piping

- Temperature - Pressure Gauge. Install temperature pressure gauge using tee and bushing provided in near boiler piping on supply side. See Figure 6-2.
- Some boiler models may have integral drain valve located inside jacket directly underneath pump. Install external drain valve as required.

### 6.5 System Piping

- Ensure plugs are removed from boiler water connections.
- See Figure 6-5 for basic system piping configurations.

- Systems with automatic fill valves require back flow prevention device.
- Single boiler system. See Figures 6-2, 6-5, for general guidance. Additional considerations:
  - Boiler control only supports integrated pump. Installer responsible for integration of multiple central heating pumps using field supplied external control.
  - Boiler control allows domestic hot water prioritization.
- Thoroughly flush all hydronic piping.
- Secure all valves/fittings to boiler.
- Manufacturer recommends installing an isolation and purge valve to use during commissioning to ensure the boiler does not shut down due to over-temperature. See figure 6-2 for details.
- Do not install isolation valve between boiler and any field installed LWCO.
- If soldering piping to boiler, avoid over heating and damaging seals and gaskets.
- Connect system valve pipe work to the boiler.
- Route pressure relief valve discharge piping to the floor. Follow local code with respect to necessary distance to the floor. See Figure 6-1.
- Verify all drain valves are closed.

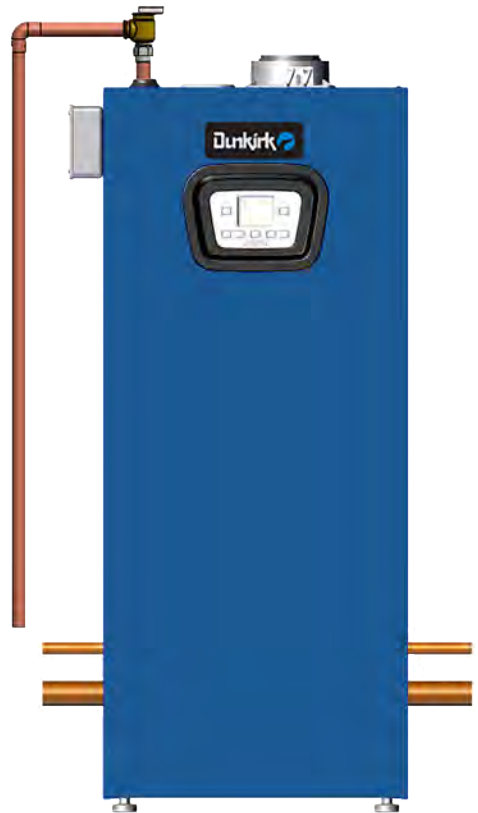
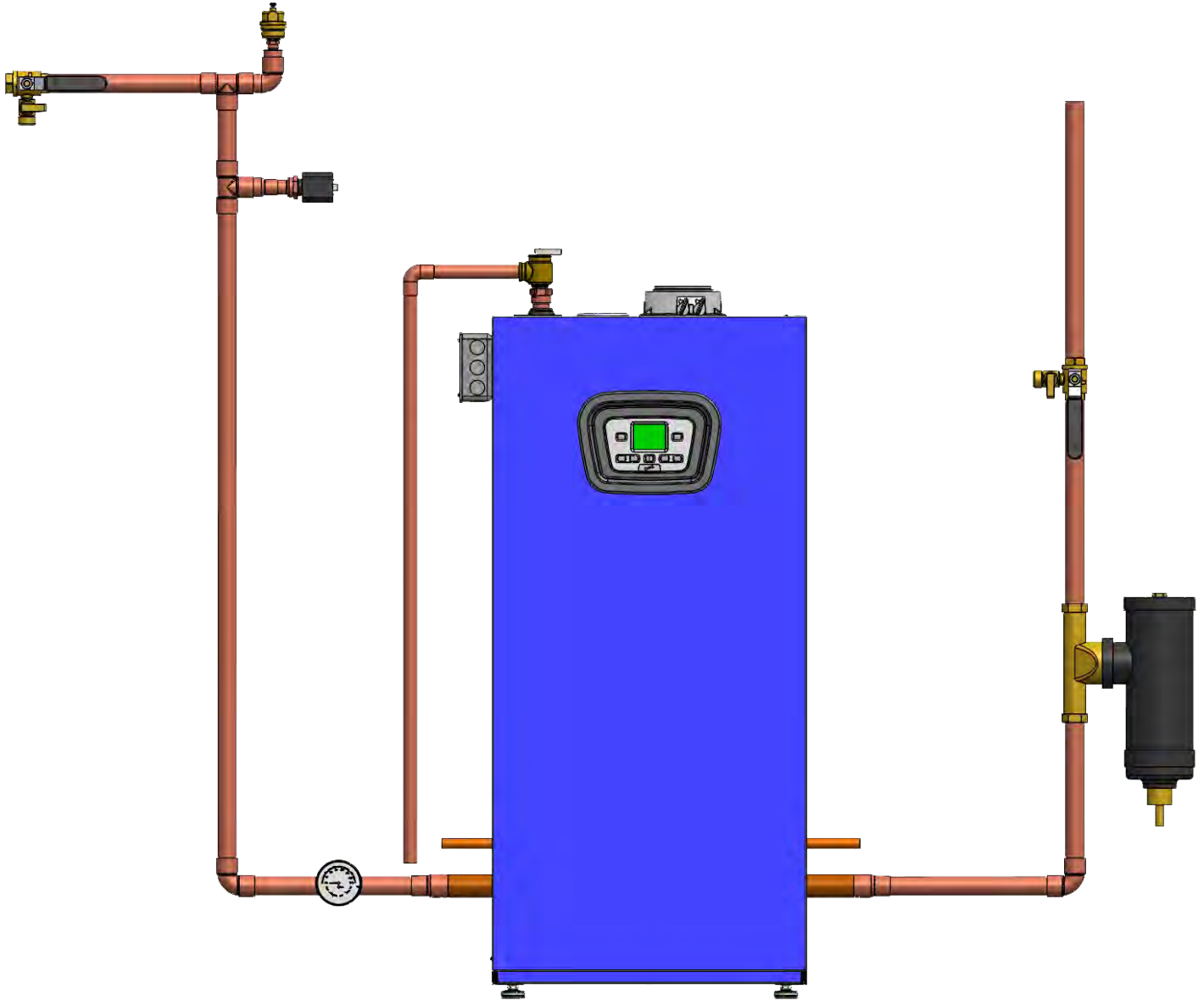


FIGURE 6-2 - Piping Diagram - LWCO Location





**6.6 External Optional Low Water Cut Off**

These guidelines are supplied when necessary to install an additional Low Water Cut Off (LWCO), for sensing a low water level condition in a boiler, as required by the Authority Having Jurisdiction.

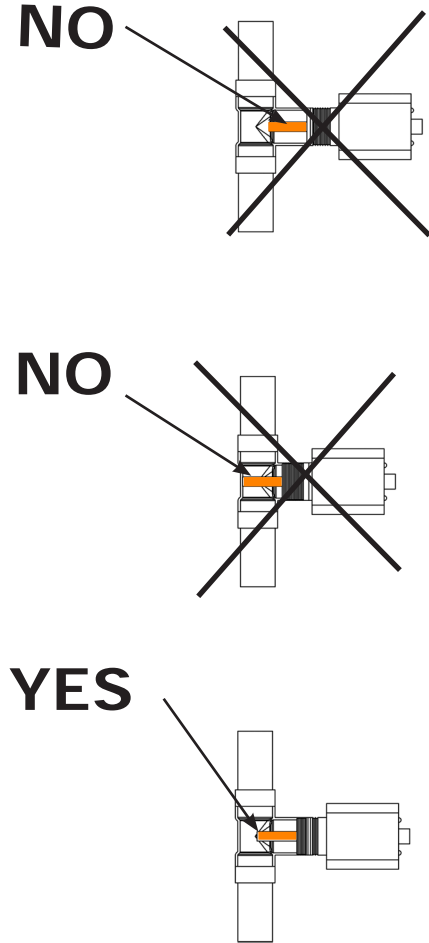
Follow LWCO manufacturer installation instructions for type of LWCO selected in addition to these instructions.

LWCO shall be 120V/60HZ control and dry contacts sized for load being connected. Wire control to boiler. See Figure 6-3.

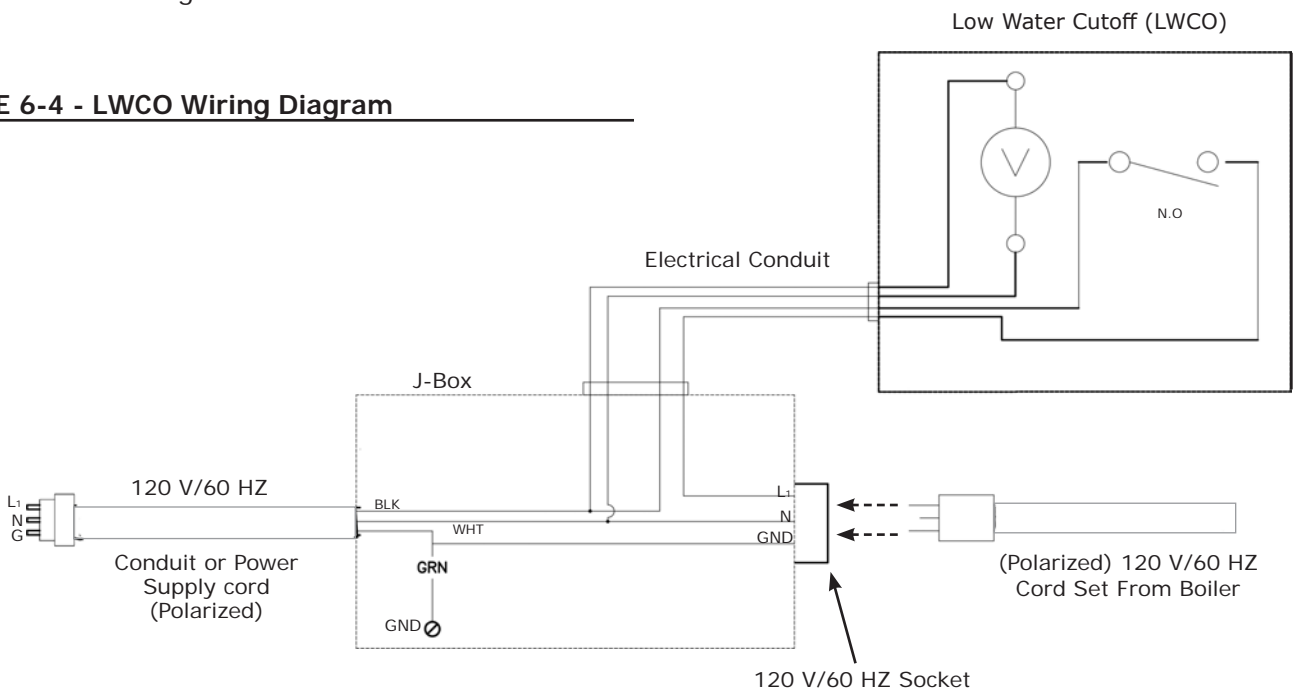
Connect LWCO device to the system ground. Ground in accordance with the requirements of the authority having jurisdiction or, in the absence of such requirements, with the National Electrical Code (NEC) or Canadian Electrical Code CEC.

- Locate LWCO sensing device in the supply piping, above the minimum height of boiler. See Figure 6-2, Piping Diagram.
- Position control in HORIZONTAL piping to assure proper boiler protection (upright or 90° rotation).
- For proper operation, sensing element of the LWCO control shall be positioned in the tee to sense the main water stream. Maintain minimum 1/4" spacing from pipe walls. Element shall NOT contact the rear, or side walls of the tee. See Figure 6-3.
- Install an air vent using a tee to avoid nuisance shutdowns.
- Apply small amount of pipe sealant to threaded connections. Use LWCO manufacturer suggested sealant.
- Arrange piping to prevent water dripping onto boiler.
- DO NOT install water shutoff valve between boiler and LWCO sensing device.

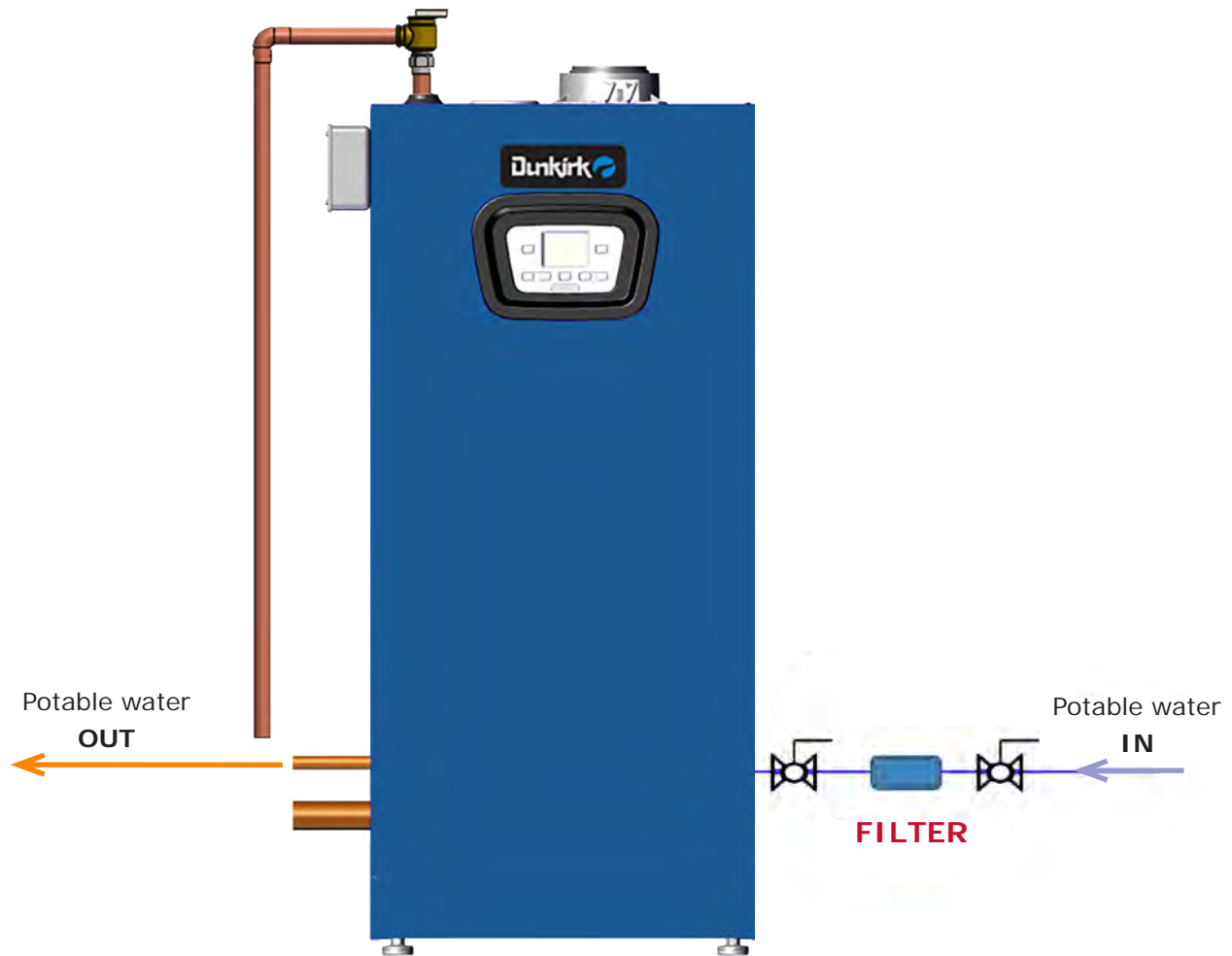
**FIGURE 6-3 - Low Water Cutoff - Detail**



**FIGURE 6-4 - LWCO Wiring Diagram**



## 6.7 Manufacturer Recommendation - Strainer on DHW Inlet



### Manufacturer Recommendation

Manufacturer strongly recommends the use of a filter filtering potable water before entering the boiler. The strainer prevents any sedimentation and debris from your water supply piping from entering the boiler. Debris carried from the water supply will clog DHW water flow sensor, potentially resulting in significant operation issues.

Locate the strainer as close to the boiler as possible and place on DHW (domestic hot water) inlet connection located at bottom of the boiler.

### 6.8 Central Heating System

Boiler is designed for use in a sealed central heating system. Design the system to operate with flow temperatures of up to 176°F (80° C), take pump head, expansion tank size, mean radiator temperature, etc. into account.

Boiler is supplied with the following components:

**Pressure relief valve** - 30.0 psi (2.1 bar). Boiler internal pressure switch will shut boiler off below 7.5 psi / 0.5 bar and above 43.5 psi / 3.0 bar.

**Pressure gauge** - to indicate the system pressure to be maintained.

**By-pass (75, 100,125)**- Boiler incorporates an automatic by-pass, However, where all radiators are fitted with thermostatic radiator valves, an external by-pass must be fitted.

### 6.9 Frost Protection Mode

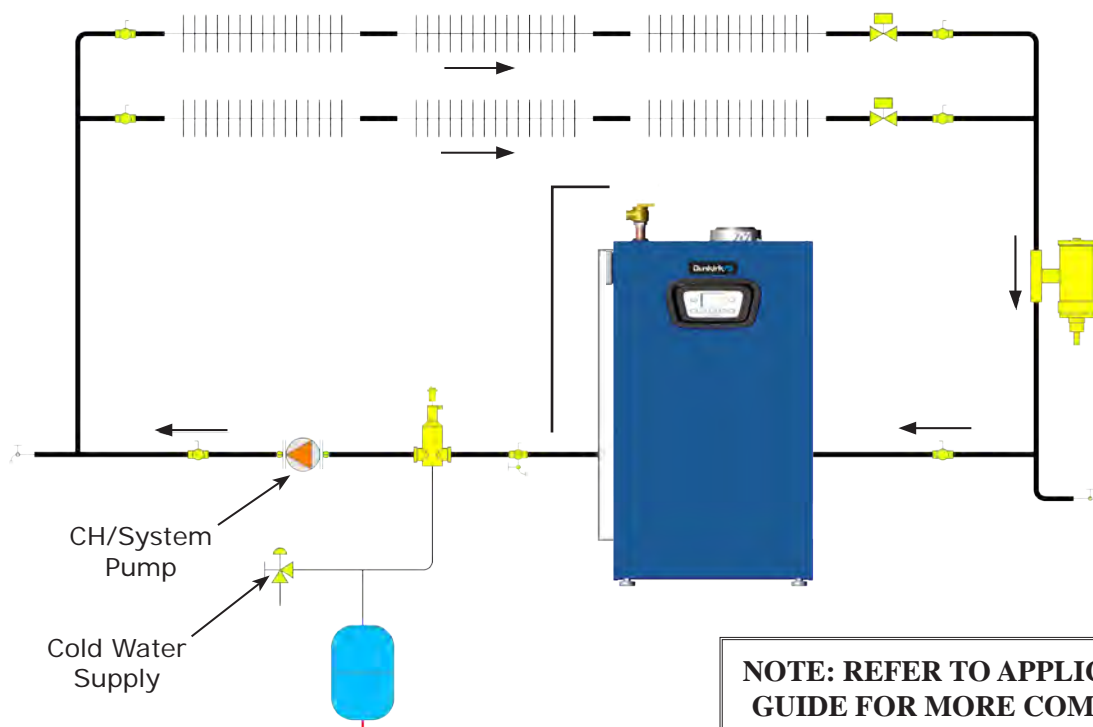
Frost protection mode is integrated into the appliance when electricity is connected to the boiler, regardless if power is "on" or "off".

If boiler water temperature falls below 41°F / 5° C boiler will fire on its minimum setting until flow temperature of 86°F / 30° C is reached.

### 6.11 Pump Protection

Pump and 3 way valve protection will automatically operate for 1 minute in every 24 hours of inactivity to prevent seizing.

**FIGURE 6-5**



## 7 - GAS SUPPLY PIPING

### ! DANGER

Fire Hazard. Do not use matches, candles, open flames, or other methods providing ignition source. Failure to comply will result in death or serious injury.

### ! WARNING

Fire, explosion, asphyxiation and burn hazard. Boiler piping and gas connections shall be leak tested before placing boiler in operation. Failure to follow these instructions and or improper installation could result in death or serious injury.

### ! CAUTION

#### WHAT TO DO IF YOU SMELL GAS

- Do not try to light any appliance.
- Do not touch any electrical switch; do not use any phone in your building.
- Immediately call your gas supplier from a neighbor's phone. Follow gas supplier's instructions.
- If you cannot reach your gas supplier, call the fire department.

### NOTICE

If overheating occurs or gas supply fails to shut off, do not turn off or disconnect electrical supply to pump. Shut off gas supply at location external to the boiler.

### NOTICE

Use of CSA approved corrugated, semi-rigid stainless steel tubing with polyethylene jacketing is approved for use with boilers following tubing manufacturer's instructions.  
Use of flexible "appliance whip" gas tubing is not allowed per NFPA 54.

**Required Gas Supply Pressure  
at Maximum Firing Rate**

Natural Gas		Liquid Propane	
Min.	Max.	Min.	Max.
3.5" w.c.	10.5" w.c.	8.0" w.c.	13.0" w.c.
(0.87 kPa)	(2.61 kPa)	(1.99 kPa)	(3.23 kPa)

### 7.1 General

- Use piping materials and joining methods acceptable to authority having jurisdiction. In absence of such requirements:
  - USA - National Fuel Gas Code, ANSI Z223.1/ NFPA 54.
  - Canada - Natural Gas and Propane Installation Code, CAN/CSA B149.1
- Install external field sourced manual main gas shutoff valve, ground joint union, and sediment trap upstream of gas controls in accordance with state and local requirements. See Figure 7-1.
- Size and install gas piping system to provide sufficient gas supply to meet maximum input at not less than minimum supply pressure.
- Boiler shall be isolated from the gas supply piping system by closing its individual manual shutoff valve during any pressure testing of gas supply piping system at test pressures equal to or less than 1/2 psi (3.40 kPa - 34.47 mbar).

**GAS SUPPLY REQUIRED:**

MODEL	NATURAL GAS (A)	LIQUID PROPANE (E)
DCBF-75	92 ft <sup>3</sup> /h (2.60 m <sup>3</sup> /h)	38 ft <sup>3</sup> /h (2.61 m <sup>3</sup> /h)
DCBF-100		
DCCF-115	114 ft <sup>3</sup> /h (3.22 m <sup>3</sup> /h)	47 ft <sup>3</sup> /h (1.32 m <sup>3</sup> /h)
DCBF-125	118 ft <sup>3</sup> /h (3.30 m <sup>3</sup> /h)	51 ft <sup>3</sup> /h (1.48 m <sup>3</sup> /h)
DCCF-150	143 ft <sup>3</sup> /h (4.00 m <sup>3</sup> /h)	61 ft <sup>3</sup> /h (1.72 m <sup>3</sup> /h)
DCBF-165	153 ft <sup>3</sup> /h (4.30 m <sup>3</sup> /h)	66 ft <sup>3</sup> /h (1.85 m <sup>3</sup> /h)
DCCF-205	191 ft <sup>3</sup> /h (5.40 m <sup>3</sup> /h)	82 ft <sup>3</sup> /h (2.30 m <sup>3</sup> /h)

- Install boiler so that gas ignition system components are protected from water (dripping, spraying, rain, etc.) during appliance operation and service (circulator replacement, condensate trap, control replacement, etc.).
- Gas meter and supply pipes must be capable of delivering the listed quantity of gas in addition to demand from any other appliances in the house. Boiler requires a minimum 3/4" (19.5 mm) gas supply pipe.
- Support piping with hooks, straps, bands, brackets, hangers, or building structure components to prevent or dampen excessive vibrations and prevent strain on gas connection. Boiler will not support piping weight.
- Use thread (joint) compound (pipe dope) suitable for liquefied petroleum gas.
- Leak test boiler and gas line connections before placing boiler into operation.

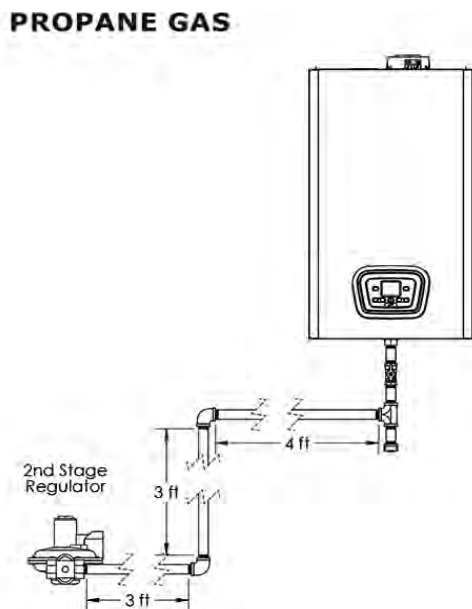
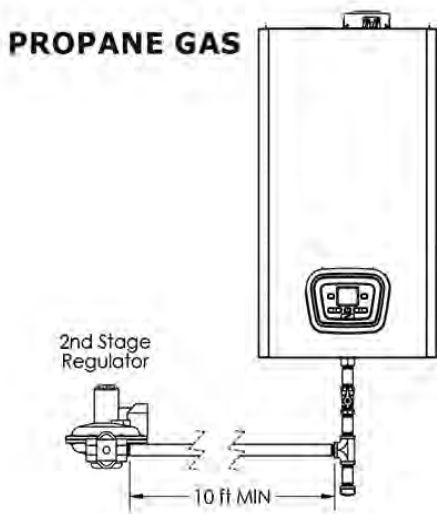
**7.2 Gas Pipe Recommendations**

Configure gas pipe for proper operation and avoid issues with failure to light or maintenance of proper flame during operation, which could cause error codes related to flame signal.

- Incoming pipe size and pressures shall be sufficient for all gas appliances in the building. See Chart next page or reference NFPA-54.
- Use only properly rated and certified materials for gas pipe.
- Use of Schedule 40 metallic pipe and Corrugated Stainless-Steel Tubing (CSST) is manufacturer recommended for best performance.

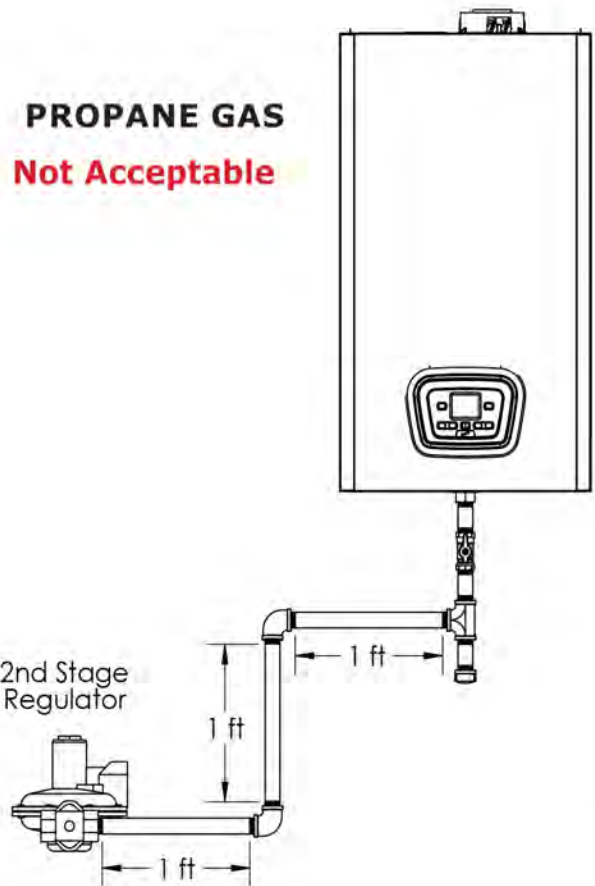
- Use of Gas Appliance Connectors (flexible connectors typically used for gas stoves or water heaters) is prohibited. Refer to national and local building codes.
- Each fitting in the gas supply pipe shall count as 5 equivalent feet.
- There shall be sufficient gas pressure at the boiler per gas used and appliance rating plate.
- For LP applications there shall be no less than 10 linear feet of properly sized gas pipe excluding fittings from the closest regulator or meter in the gas supply piping.

**ACCEPTABLE PIPING FOR PROPANE**



**NOT ACCEPTABLE PIPING**

3 Elbows = 15 ft  
 3 Linear feet = 3 ft  
 Total equivalent = 18 ft





## 7 - GAS SUPPLY PIPING

This chart is sourced from NFPA-54 2015 with the BTU ratings for the material, length, and diameter of gas pipe.  
**INTENDED USE:** Pipe Sizing Between Natural Gas Meter, or Propane Single - or Second-Stage (Low-Pressure) Regulator and Appliance.

<b>INTENDED USE: Pipe Sizing Between Natural Gas Meter, or Propane Single- or Second-Stage (Low-Pressure) Regulator and Appliance.</b>								
<b>Schedule 40 Metallic Pipe</b>								
Gas:	Natural				Undiluted Propane			
Inlet Pressure:	Less than 2 psi				11.0 in. w.c.			
Pressure Drop:	0.5 in. w.c.				0.5 in. w.c.			
Specific Gravity:	0.60				1.50			
Nominal ID (inches):	3/4		1		3/4		1	
Length (ft)	Capacity in Thousands of Btu per Hour				Capacity in Thousands of Btu per Hour			
10	360		678		608		1,150	
20	247		466		418		787	
30	199		347		336		632	
40	170		320		287		541	
50	151		284		255		480	
60	137		257		231		434	
80	117		220		212		400	
100	104		195		197		372	
<b>Corrugated Stainless Steel Tubing (CSST) w/ pressure drop of 0.5 inches w.c.</b>								
Gas:	Natural				Undiluted Propane			
Inlet Pressure:	Less than 2 psi				11.0 in. w.c.			
Pressure Drop:	0.5 in. w.c.				0.5 in. w.c.			
Specific Gravity:	0.60				1.50			
Tube Size (inches):	3/4		1		3/4		1	
Flow Designation (EHD):	23	25	30	31	23	25	30	31
Length (ft)	Capacity in Thousands of Btu per Hour				Capacity in Thousands of Btu per Hour			
10	161	192	330	383	254	303	521	605
20	116	137	231	269	183	216	365	425
30	96	112	188	218	151	177	297	344
40	83	97	162	188	131	153	256	297
50	75	87	144	168	118	137	227	265
60	68	80	131	153	107	126	207	241
80	60	69	113	132	94	109	178	208
100	54	62	101	118	85	98	159	186

**NOTICE**

Sediment trap shall be located upstream of gas controls.

**7.3 Leak Check Gas Piping**

Pressure test boiler and gas connection before placing boiler in operation.

- Pressure test over 1/2 psig (3.5 kPa). Disconnect boiler and its individual gas shutoff valve from gas supply system.
- Pressure test at 1/2 psig (3.5 kPa) or less. Isolate boiler from gas supply system by closing manual gas shutoff valve.
- Locate leakage using gas detector, noncorrosive detection fluid, or other leak detection method acceptable to authority having jurisdiction. Do not use matches, candles, open flames, or other methods that can provide ignition source.
- Correct leaks immediately and retest.

**7.4 Gas Orifice** - See Figure 7-2

- Models 75, 100, 115 = 4.6 mm ( Natural & LP)
- Models 125, 150 = 5.8 mm ( Natural & LP)
- Models 165, 205 = 9.0 mm ( Natural & LP)

Figure 7-1 - Gas Piping

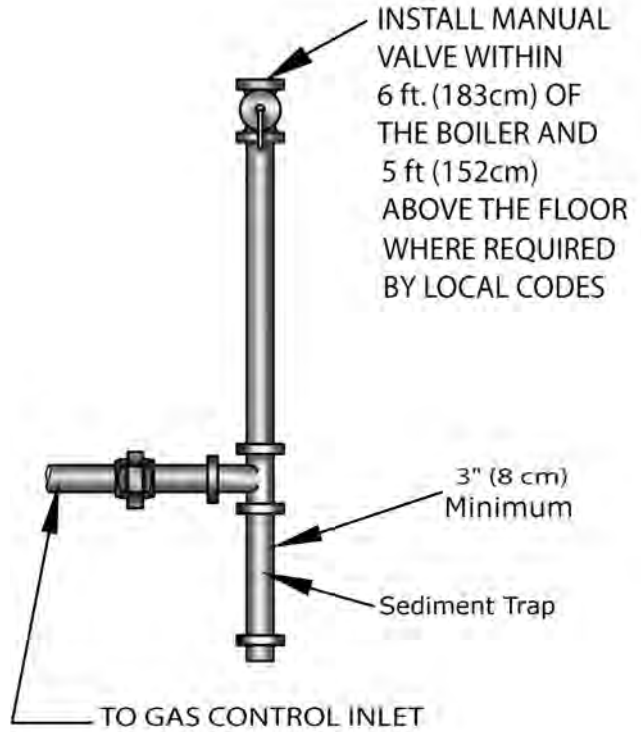
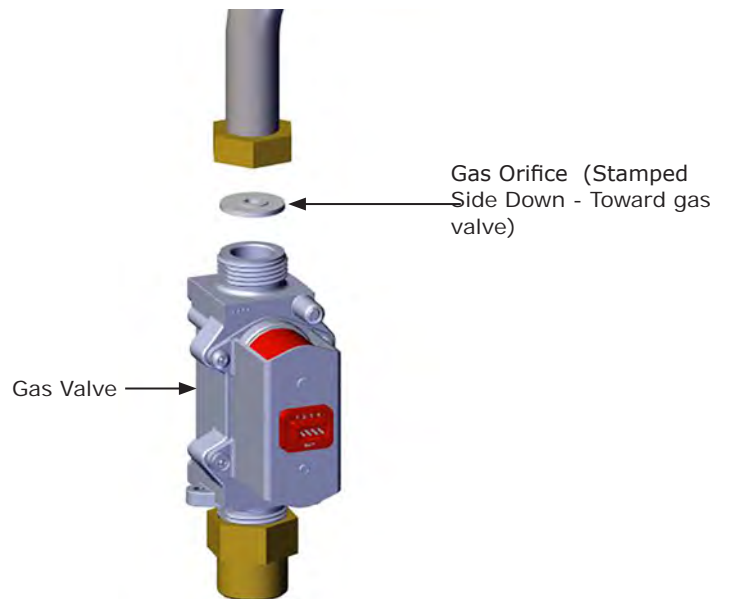


FIGURE 7-2 Gas Orifice Location



## 8 - ELECTRICAL CONNECTIONS

### ⚠ DANGER

Electrocution Hazard! HIGH VOLTAGE - Connections in terminal block M1 are high voltage (120V / 60Hz). Before making connections, verify appliance is disconnected from power supply. Respect the input polarity on terminal block M1: L (LINE) - N (NEUTRAL). Failure to follow these instructions WILL result in death or serious injury.

### ⚠ WARNING

Electrical shock hazard. Turn OFF electrical power supply at service panel before making electrical connections. Failure to do so could result in death or serious injury.

Model Size	75 & 100	115	125	150	165	205
Power Supply	120V - 60Hz					
Power Consumption	118 W	125 W	133 W	142 W	173 W	182 W
Internal Fuse (Qty. 2)	F3.15 A					
Electrode Spark Gap	1/8" to 3/16" [3.1 mm to 4.7 mm]					

**Note** Wiring diagrams can be found in Appendix A of this Manual.

### 8.1 General

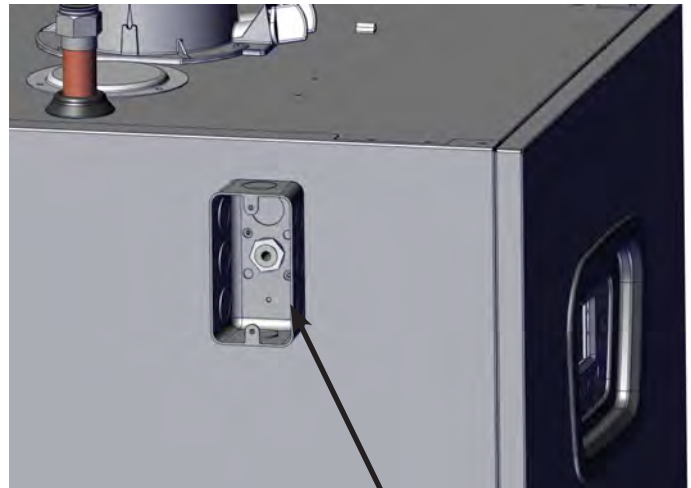
Electrically bond boiler to ground in accordance with requirements of authority having jurisdiction. Refer to:

- USA- National Electrical Code, ANSI/NFPA 70.
- Canada - Canadian Electrical Code, Part I, CSA C22.1: Safety Standard for Electrical Installations.
- Install all wiring in accordance with requirements of National Electrical Code and any additional national, state, or local code requirements having jurisdiction.
- In Canada, installation must conform to CSA C22.1 Canadian Electrical Code Part 1 and any local codes.
- All wiring shall be N.E.C. Class 1.
- Boiler shall be electrically grounded in accordance with the National Electrical Code, ANSI/NFPA No. 70-latest edition.
- Boiler requires a 120V 60Hz power supply. Ensure electrical supply is polarized.
- There shall only be one common isolator, providing complete electrical isolation, for boiler and any external controls. Using PVC insulated cable 12 AWGx3C 221°F (105 °C).

### 8.2 Electrical Connections

- Boiler requires 120V 60Hz power supply. Verify electrical supply is polarized.
- Boiler shall be grounded and on dedicated circuit.
- Shall be one common isolator, providing electrical isolation for boiler and any external controls. Using PVC insulated cable 18 AWGx3C 221°F (105°C).
- All wiring must be installed in accordance with requirements of the National Electrical Code and any additional national, state, or local code requirements having jurisdiction. All wiring must be N.E.C. Class 1.
- Canada, installation must conform to CSA C22.1 Canadian Electrical Code Part 1 and any local codes.
- If replacing original boiler wiring use only TEW 105°C or equivalent.
- If appliance is connected to in floor system, install limit thermostat to prevent latter from overheating.

**FIGURE 8-1 Junction Box Left side of Boiler**



Junction Box with Knockouts and grommets

### ⚠ DANGER

Electrocution Hazard! HIGH VOLTAGE - Connections in terminal block M1 are high voltage (120V / 60Hz). Before making connections, verify appliance is disconnected from power supply. Respect the input polarity on terminal block M1: L (LINE) - N (NEUTRAL). Failure to follow these instructions WILL result in death or serious injury.

### 8.3 Access To Connection Block

1. Ensure there is no line voltage at boiler.
2. Lift and remove front cover. Remove screws (2) from cover on junction box located on boiler's left side. Remove junction box cover.
3. Guide controller or thermostat wire through round grommet(s) located on top panel of boiler.
4. Tilt control box forward by opening holding clip located on left side of control housing.
5. Expose M1 and M2 terminal blocks by removing screw from plastic cover on left. See Figure 8-3.
6. Remove plastic from channel in plastic cover. Run wires through new opening.
7. Connect wires to appropriate terminals on connection block.
8. Tilt control box back to original position. Ensure clip on left side of control box is fully engaged.
9. Replace front cover and cover to junction box.
10. Turn power to boiler on.

Dry contact end switches from various manufacturers can be attached to boiler control PCB.

### 8.4 Main Supply Connection

Main supply is connected to terminal block **M1** which is high voltage (120V / 60Hz).

Fuses, 3.15 A, are incorporated in the power supply terminal block. To check or replace fuse pull out black fuse carrier.

#### TERMINAL BLOCK M1

(L) = Live (brown)

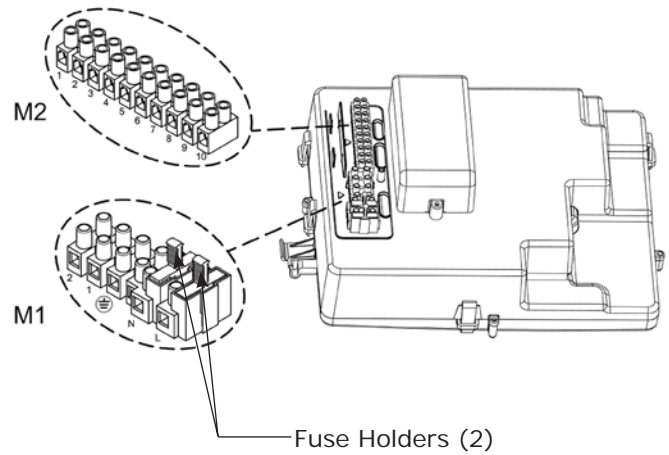
(N) = Neutral (light blue).

= Ground (yellow-green).

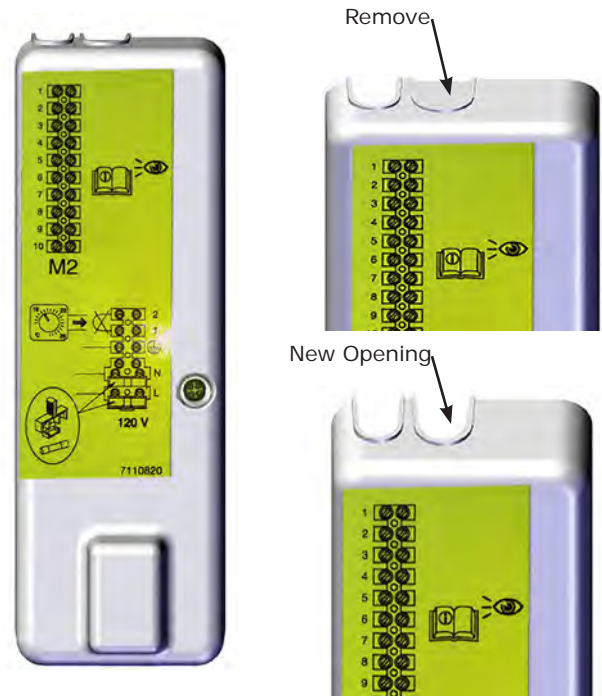
(1) (2) = contact for 120V Room Thermostat.

Place jumper back on terminals 1-2 of boiler terminal block **M1** if room thermostat is not used

**FIGURE 8-2 Terminal Block Locations**



**FIGURE 8-3 Terminal Plastic Cover with Knockouts**



#### TERMINAL BLOCK M2

**Terminals 1 - 2:** Buss connection of Open Therm

**Terminal 3 :** Not used on Combi units

**Terminals 3 - 4:** Indirect storage tank sensor connection for heat-only boilers

**Terminal 4 - 5:** Outdoor temperature sensor connection (supplied as an accessory)

**Terminals 6 - 7 - 8:** 24V room thermostat connection

**Terminals 9 - 10:** 0 - 10V connection

### 8.5 Install Room Thermostat

Install room end switch on inside wall. Do not install where it will be influenced by drafts, hot or cold water pipes, lighting fixtures, television, sun rays or near a fireplace.

**Dry contact only - do not apply 24 volts between 6 and 7.**

#### A. Connect Room Thermostat

- turn power off to boiler;
- access terminal block **M2**;
- connect room end switch to terminals **6(R)**-**7(W)**-**8(C)**; Do not apply dry voltage between 2 terminals. Dry contact only.
- turn boiler power on;
- verify room end switch operates per end switch manufacturer instructions.

**NOTE:** maximum load allowed is 10 mA





Dry contact end switches from various manufacturers can be attached to boiler control PCB.

### 8.6 Outdoor Air Sensor (OAS) Electrical Connections

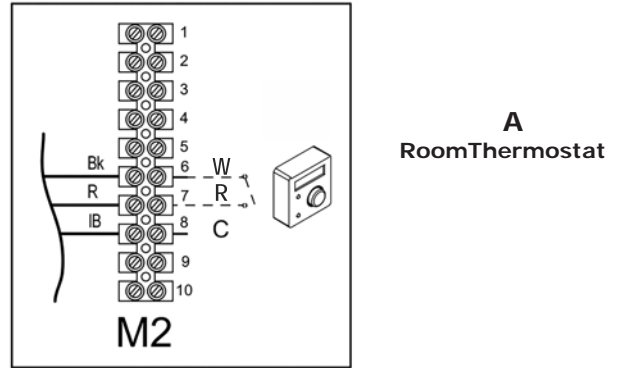
#### A. 1K Ohm (1K $\Omega$ ) Optional Outdoor Air Sensor (OAS)

To connect this accessory, see Figure 8-5, terminals 4-5, and instructions supplied with **1K  $\Omega$**  sensor and instructions supplied with **1K  $\Omega$**  sensor.

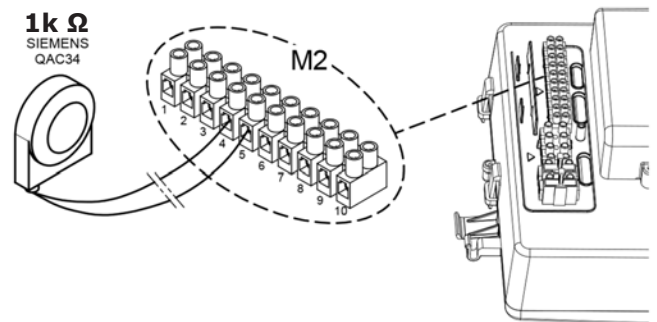
#### B. Setting "Kt" Climate Curve

1. Boiler automatically recognizes OAS sensor when wired to M2 terminal block. Display changes to show current default "**Kt**" value (80). Note display value.
2. When operating in CH mode, boiler setpoint is determined by the **Kt** value selected and actual outside air temperature. Refer to applicable °F (or °C) chart, (pg. 30) for setpoint information.
  - Select **Kt** range which will satisfy the desired boiler delivery temperature based on outdoor temperature range expected for your location. For example: if you need 176°F water when the outside temperature is 20°F and colder, select 35 for your **Kt** setting.
  - To change "default" **Kt** value on boiler control use  or  CH Heating buttons.
  - Restrict the upper limit of the **Kt** curve by using Parameter P16 to set the maximum boiler water temperature. P16 Default is 176°F.
3. When scrolling has stopped, boiler will automatically "SAVE" value as new **Kt** default value and automatically return to CH mode when no **Kt** adjustment activity is sensed. **Kt** values can be changed in +/- 1 point increments.
4. To return, to verify or change current **Kt** "default" value, depress one of the CH setpoint adjustment buttons (once),  or , while in any heating or standby mode. Adjust **Kt** value to obtain desired comfort level.

**FIGURE 8-4 Thermostat Connections**



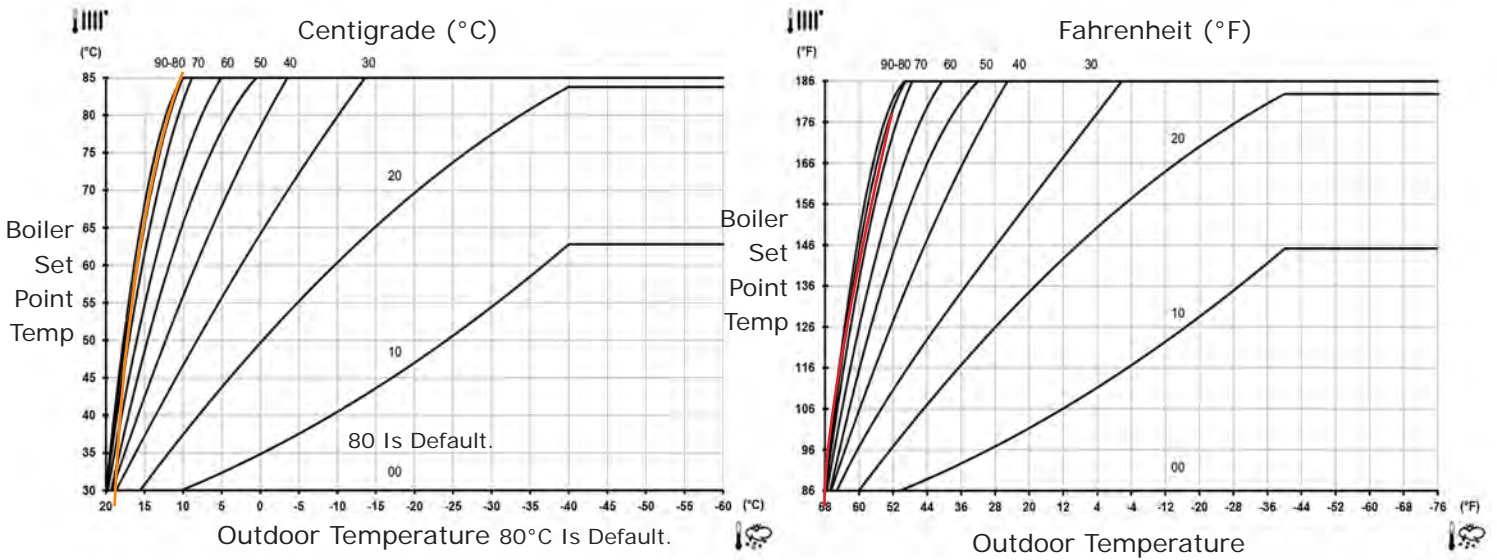
**FIGURE 8-5 Outdoor Sensor Connections**



**Note** Sensors used for this boiler are proprietary to the manufacturer. Use of after market sensors will diminish boiler performance.



**FIGURE 8-6 Kt Climate Curves**





**NOTE:** Temperatures below -40 °F (-40 °C), maximum heating flow temperature set point no longer increases, curves shown on graph become horizontal.

## 8 - ELECTRICAL CONNECTIONS

### 8.7 Indirect Storage Tank

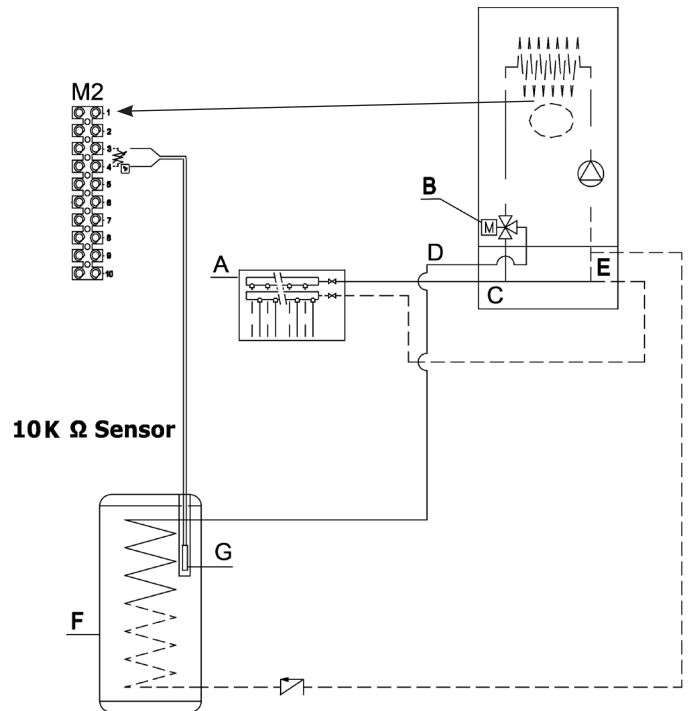
Boilers DCBF - 75, 100, 125 can be electrically connected to indirect storage tank as follows:

- Connect DHW priority **10K Ω** sensor NTC to terminals **3-4** on terminal block **M2**.
- Insert **10K Ω** NTC sensor element in the sensor well of indirect storage tank.
- Verify exchange capacity of the storage boiler coil is appropriate for boiler power.
- Adjust DHW temperature +95 °F...+140 °F (+35 °C...+60 °C) by pressing   on boiler Control.

**Note** Sensors used for this boiler are proprietary to the manufacturer. Use of after market sensors will diminish boiler performance.

**FIGURE 8-7 Kt Indirect Storage Tank**

\*125 Model shown - See Application Guide for sizes 75, 100



<b>A</b>	Heating system
<b>B</b>	Three way diverter valve
<b>C</b>	Heating water flow
<b>D</b>	Heating supply to DHW indirect storage tank coil
<b>E</b>	Heating water return
<b>F</b>	Tank
<b>G</b>	Optional 10k Ω DHW priority sensor

### 8.9 Management of 0-10V Input

The functions with 0...10V regulator are activated by means of their parameters:

To enable 0-10V input change **P82=4** to **P82=3**,

When **P78=1** the input manages the *heating set point temperature directly*.

When **P78=2** the input manages the *heating power input directly*.

Demand is activated above 3V and heating setpoint is calculated in proportion to deviation from 3 to 10 V DC, to give a setpoint that goes from minimum to maximum.

Terminal # 9 is negative (-), terminal #10 is positive (+).

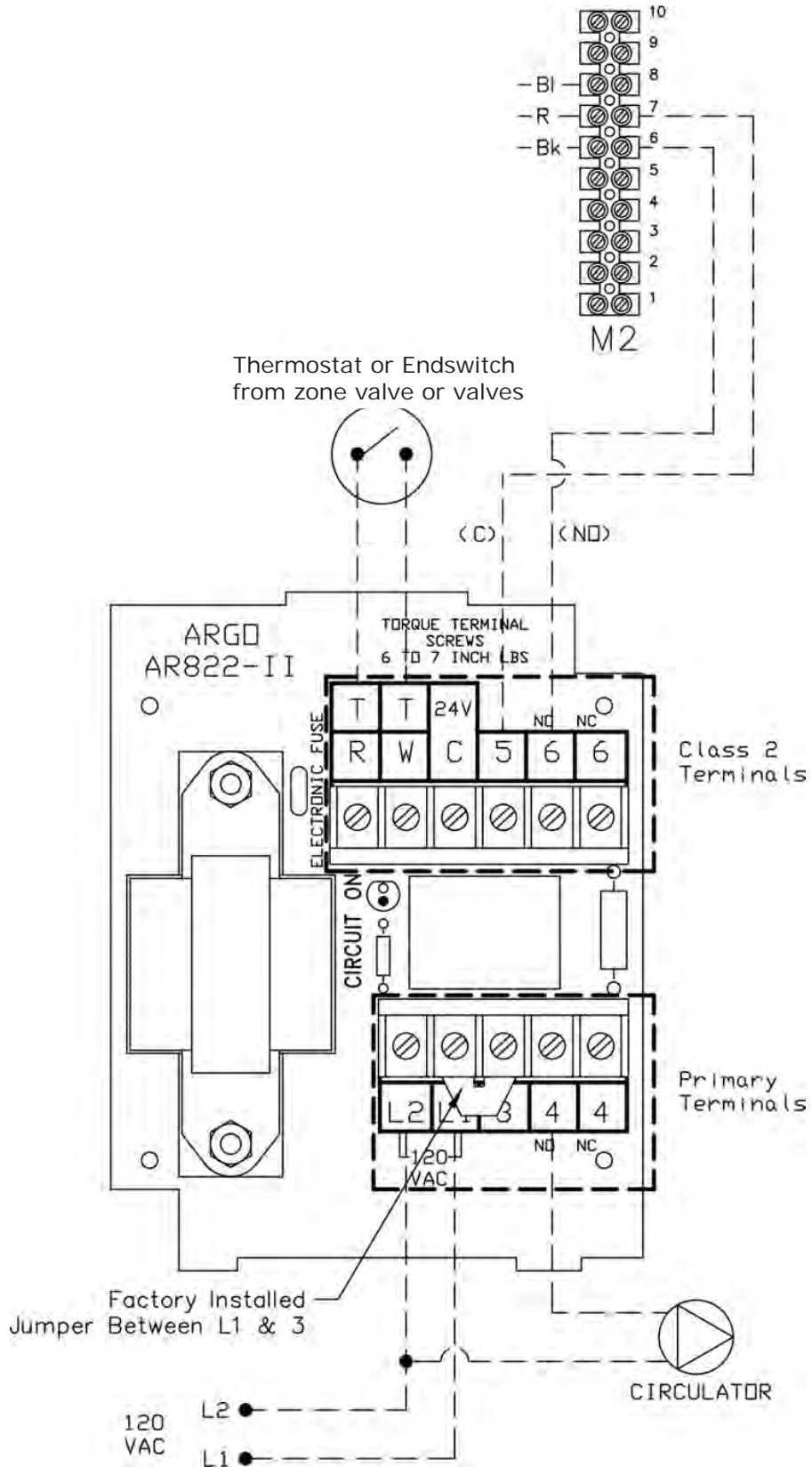
Voltage	<b>P78=1</b>		<b>P78 = 2</b>							
	Temp Setting		<b>75</b>		<b>100/115</b>		<b>125/150</b>		<b>165/205</b>	
	°C	°F	kW	MBH	kW	MBH	kW	MBH	kW	MBH
0-3	OFF									
3	25	77	4.9	16.6	4.9	16.6	6.4	22.0	8.6	29.5
4	32	90	7.3	24.9	8.4	28.9	10.7	36.5	14.4	49.0
5	40	104	9.7	33.3	12.0	40.8	14.9	51.0	19.9	68.0
6	49	120	12.2	41.6	15.4	52.4	19.2	65.5	25.5	87.0
7	57	135	14.7	50.0	18.5	63.1	23.4	80.0	31.1	106.0
8	65	149	17.1	58.3	22.2	75.7	27.7	94.5	36.6	125.0
9	73	163	19.5	66.6	25.3	86.2	31.9	109.0	42.5	145.0
10	80	176	21.2	75.0	27.4	93.6	36.9	125.0	48.1	164.0

## 8 - ELECTRICAL CONNECTIONS

**FIGURE 8-8 Circulator Pump Connections**

For more information please review the application guide received with your boiler.

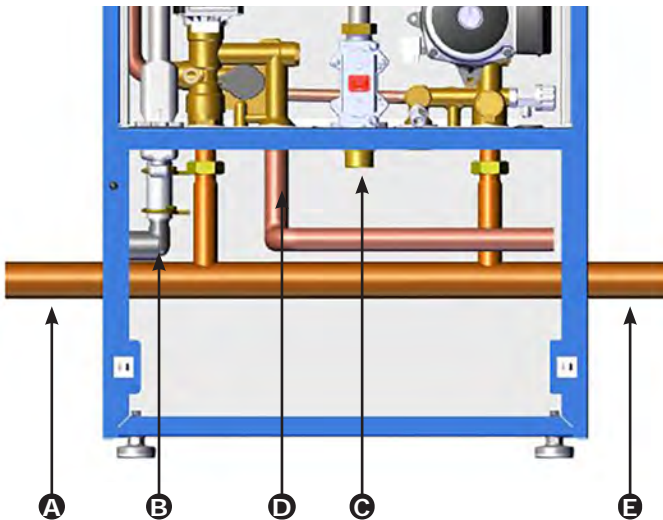
A field supplied pump relay is necessary for system pumps.



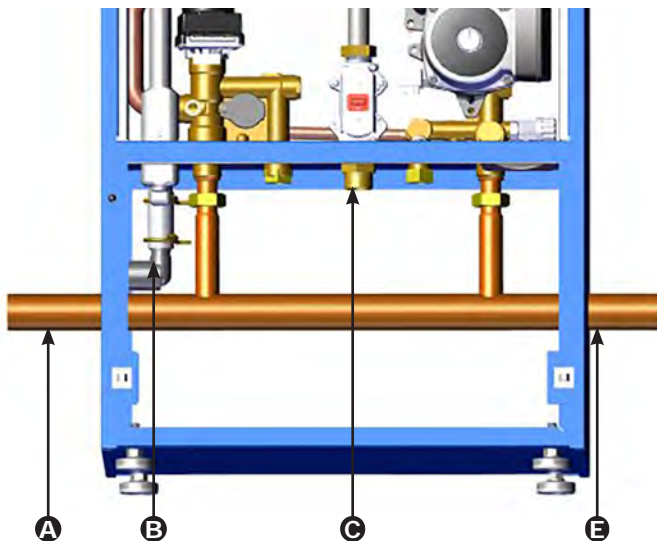
## 9 - START UP PROCEDURE

### 9.1 Central Heating System Connections - HEAT ONLY

#### DCBF-75, 100 & 125 HEATING ONLY WITH OPTIONAL INDIRECT DHW CONNECTION



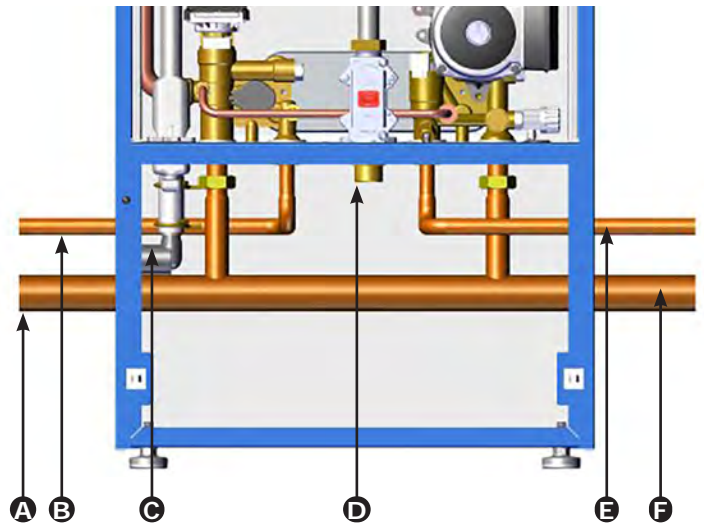
#### DCBF-75, 100, 125 HEATING ONLY WITHOUT OPTIONAL INDIRECT DHW CONNECTION



LEGEND		75/100 / 125	165
A	Heating supply connection	1 1/4" sweat [31.75 mm]	1 1/2" sweat [38.1 mm]
B	Drain Connection for condensate	3/4" NPT [22.2 mm]	
C	Gas shutoff connection	3/4" NPT [22.2 mm]	
D	Optional Indirect DHW connection (may exit right or left)	3/4" sweat [22.2 mm]	NA
E	Heating return connection	1 1/4" sweat [31.75 mm]	1 1/2" sweat [38.1 mm]

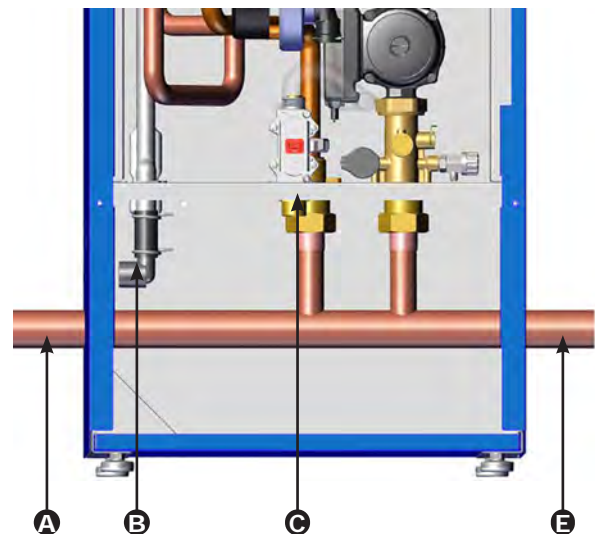
### 9.2 Central Heating System Connections - Combi

#### DCCF- 115, 150, & 205 COMBI (150 shown)



LEGEND		75/100/115/150	205
A	Heating supply connection	1 1/4" sweat [31.75 mm]	1 1/2" sweat [38.1 mm]
B	DHW outlet	1/2" sweat [12.7 mm]	3/4" sweat [19.1 mm]
C	Drain connection for condensate	3/4" NPT [22.2 mm]	
D	Gas shutoff connection	3/4" NPT [22.2 mm]	
E	Cold DHW inlet tap	1/2" sweat [12.7 mm]	3/4" sweat [22.2 mm]
F	Heating return connection	1 1/4" sweat [31.75 mm]	1 1/2" sweat [38.1 mm]

#### DCBF-165 HEATING ONLY WITHOUT INDIRECT DHW CONNECTION





### 9.3 System Start Up

Follow all codes and regulations when filling the boiler. Use drain taps to allow system to completely drain. Thoroughly flush the heating system before boiler is connected and again after first heating season.

- Boiler is fitted with automatic air vent positioned on pump Vent and is fitted with adjustable sealing cap. See Figure 9-1.
- Open central heating flow and return valves. Spindle is flat in-line with valve.
- Open fill point valve on filling system until water begins to flow. To aid venting boiler drain may be open until water flows out. Close drain as soon as water appears.
- During initial system air purge open valve connected to top left of heat exchanger. Open four (4) full turns counterclockwise until steady stream of water is witnessed. Close fully turning clockwise with no tools needed. See Figure 9-1.
- Systems using radiators to remove air - Vent each radiator in turn, starting with lowest in the system.
- It is **IMPORTANT** the pump is properly vented to avoid running it dry and damaging its bearings. Unscrew and remove cap from center of pump. Use screwdriver. Rotate exposed spindle about half turn, replace cap.
- Check operation of heating pressure relief valve. Pull lever on top of valve upwards lifting the seat. This will allow water to escape from system. Check water is escaping from the system.
- Open combi models only domestic cold water inlet valve. Turn on all hot water taps. Allow water to flow until no air is present. Turn off taps. See page 4 - Physical Data and section 2.7 Operational Features.

### 9.4 Fill Condensate Trap with Water

#### ⚠ WARNING

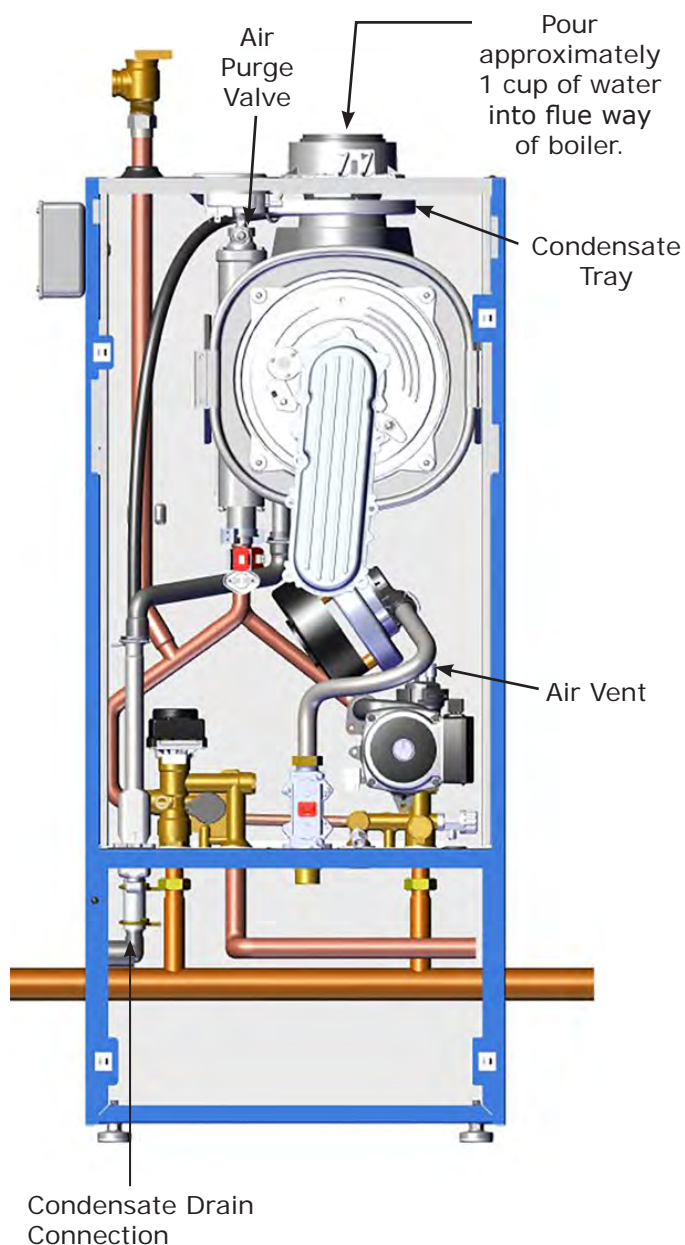
Asphyxiation hazard! Fill condensate trap before starting boiler to avoid combustion products escaping boiler. Failure to follow these instructions could result in death or serious injury.

- To fill the condensate trap pour water into exhaust vent until water begins to flow through the siphon.
- Visually inspect the siphon to ensure it is full with clean water.
- During operation check condensate trap to ensure it drains properly.

**Note** Condensate trap must be manually filled with water at initial start up.

**FIGURE 9-1 Condensate Drain Assembly**

150 Model shown (location similar in all sizes)





## 9 - START UP PROCEDURE

### 9.5 Control Panel

To enter the **INFO** Menu press and hold **iIP** for 1 second.

Press and hold the **iIP** button for 1-2 seconds to increment through the selections as shown in the table below.

Press **⊕/R** to exit.

<b>i</b>	DESCRIPTION	<b>i</b>	DESCRIPTION
<b>00</b>	Secondary fault internal code	<b>09</b>	Setpoint Central Heating (°F/°C)
<b>01</b>	Heating flow temperature (°F/°C)	<b>10/11</b>	Manufacturing information
<b>02</b>	Outdoor temperature (°F/°C)	<b>12</b>	Flue sensor temperature (°F/°C)
<b>03</b>	Indirect Tank DHW temperature (boiler CH only)	<b>13</b>	Manufacturing information
<b>04</b>	Domestic hot water temperature (boiler with plate exchanger)	<b>14</b>	Identification Open Therm communication
<b>05</b>	Water pressure in heating system (PSI/bar)	<b>15</b>	Manufacturing information
<b>06</b>	Heating return temperature (°F/°C)	<b>16</b>	Manufacturing information
<b>07</b>	Thermo fuse status (000/001)	<b>17</b>	Fan speed ("i17"x100)
<b>08</b>	Not used	<b>18</b>	Manufacturing information

### BUTTONS Key

	DHW temperature adjustment (+ to increase the temperature and - to decrease it)
	Heating water temperature adjustment (+ to increase the temperature and - to decrease it)
	Boiler operating information
	Operating mode: DHW – DHW & Heating – Heating Only
	ON/Off – Reset – Exit menu/functions



### SYMBOL Key

	Off: heating and DHW disabled (only boiler frost protection is active)		Burner lit
	Ignition fault		DHW operating mode enabled
	Boiler/system water pressure low		Heating mode enabled
	Call a qualified service technician	<b>P</b>	Programming menu
	Manually resettable fault ()	<b>i</b>	Boiler information menu
	Fault in progress	°C, °F, bar, PSI	Set unit of measurement (SI/US)

### ! WARNING

Asphyxiation hazard! Fill condensate trap before starting boiler to avoid combustion products escaping boiler. Failure to follow these instructions could result in death or serious injury.

### NOTICE

All connections shall be made and water added before performing this function.

#### 9.6 Prior to Commissioning:

- Verify door is ON boiler;
- Check system pressure is correct;
- Power boiler;
- Open gas tap (positioned under boiler);
- Select required heating mode. See section 10.4 Operating Modes.

#### 9.7 Commissioning For The First Time:

1. Turn power to boiler on. Code "000" appears on the display. Appliance is ready for "commissioning" procedure.
2. Press and at the same time. **Hold for 6 seconds.** "On" appears on the display for 2 seconds followed by code "312" indicating "de-aeration" function is active. This function lasts 10 minutes.
3. Burner will ignite after deaeration function is complete. Display will show code "000" alternating with % of ignition power and temperature value (°F / °C).
  - During this **gas recognition function** phase which lasts about 7 minutes, type of gas being used is analyzed.
  - During this function, ensure maximum heat exchange out to the system with all zones and circulators running. Maintain system temperature below 176° F for duration of the process until **NG** or **LPG** are seen on the display.
  - If boiler operates on Gas A (Natural Gas) and display shows **LPG** (Gas E), press and together and hold down for at least 4 seconds to exit without changing factory setting. Boiler will stay set to Natural Gas.
  - If boiler operates on Gas A (Natural Gas), display shows **NG** (Natural Gas) for about 10 seconds. Boiler is now ready for normal operation.
  - If boiler operates with **Gas A** (Natural Gas) and the display shows **LPG** (Gas E), press and together and hold down for at least 4 seconds to exit the function. Change parameter **P02=01** as described in section 9.15 Parameter Settings of boiler Installation, Operation and Maintenance Manual. Perform Automatic Calibration Function. Manual Calibration may be necessary if combustion is not within specified range.
  - If boiler operates on Gas E (LPG) and display shows **LPG**, press for at least 6 seconds to confirm gas used.
  - After fuel type is detected confirm **P02** is set for the desired fuel type by checking parameter see section 9.15.
4. During Gas Recognition Function, firing rate will increase for a short period of time while gas type is being established.

5. If deaeration or gas recognition function is interrupted by power blackout, start function again when power is restored. Press and together and hold at same time for at least 6 seconds.

**Note** **Boiler must not shutoff during calibration. Open all heating zones in heating or DHW mode to ensure boiler does not shutoff.**

#### 9.8 Automatic Calibration Function

Before performing this function verify the door is on the boiler and there are no heat demands in progress.

During this function ensure there is maximum heat exchange to the system in Heating or DHW mode (DHW request) to avoid boiler shutting off due to overheating.

Press and together and hold for about 6 seconds. When display indicates "On" press within 3 seconds after pressing previous buttons.

### NOTICE

**Important:** If display indicates "303" Automatic Calibration function has not been activated. Disconnect boiler from main power supply for few seconds and repeat procedure.

1. When function is enabled, and will flash on the display.
2. After ignition sequence, which can also take place after few attempts, boiler performs three operations. Each operation lasts about 1 minute:
  - maximum power
  - ignition power
  - minimum power
3. Before moving to the next combustion point the **P** and appear on the display as the control is setting values.
4. During this phase, power level reached by boiler and delivery temperature alternate on the display.
5. When , and flash together on the display, automatic calibration function has completed.
6. Press to exit the function. Display will show **ESC**.
7. Verify combustion is within specified range. If not, perform Automatic and then Manual Calibration. (See Sections 9.8 & 9.9)

### NOTICE

















**IMPORTANT:** If Calibration function does not complete, verify unit did not shut down for over-temperature. Repeat Automatic Calibration.

### 9.9 Manual Calibration Function:




Manual Calibration phase starts at the end of the Automatic Calibration.

The Display shows the boiler power and adjustment of the CO<sub>2</sub> value (parameter setting) during Manual Calibration sequence.

The process begins at minimum power.





- A. After Automatic Calibration sequence with    flashing together on the display, you can adjust minimum power combustion by pressing  to lower % CO<sub>2</sub>, and  to raise % CO<sub>2</sub>.
- B. When minimum power combustion is in the specified range, press  and then  to reach ignition power.
- C. Press  to adjust ignition power combustion. Press  to lower % CO<sub>2</sub>, and  to raise % CO<sub>2</sub>.
- D. When ignition power combustion is in the specified range, press  and then  to reach maximum power.
- E. Press  to adjust maximum power combustion. Press  to lower % CO<sub>2</sub>, and  to raise % CO<sub>2</sub>.
- F. When maximum power combustion is in the specified range, press  to exit Manual Calibration Function. **ESC** is displayed on the screen.

### IMPORTANT INFORMATION

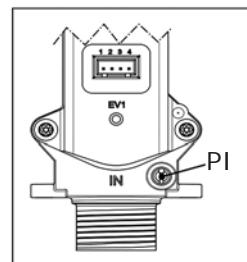
- A. If display shows fault **E118** (low pressure in hydraulic circuit) open filling tap on appliance and restore correct pressure.
- B. If gas recognition function is interrupted due to fault (e.g.: **E133** no gas) press  to reset. Then press  and  (for at least 6 seconds) to restart the function again.  
If gas recognition function is interrupted due to overheating, restart function by pressing and holding down together for at least 6 seconds.
- C. Combustion of this appliance is factory default for operation to Natural gas.
- D. Type is being established.

### 9.10 De-Aeration Function

Used to eliminate air inside the heating circuit when boiler is installed or after maintenance when water is drained from primary circuit.

1. Press buttons   together and hold for 6 seconds. **On** appears on display for a few seconds, followed by program row **312**.
2. The electronic board will activate pump on/off cycle for 10 minutes. Function will automatically stop at end of cycle.
3. To manually exit this function, press   buttons together and hold for 6 seconds.

**FIGURE 9-3 - Gas Inlet Tap - Pi**



PI = Gas Supply Inlet Pressure Tap

### 9.11 Changing The Type Of Gas

If change of gas type is required **after** first installation:

- Change parameter P02. See section 9.6 **Commissioning** and **section 9.15** Parameter Settings.
- Check minimum gas pressure is suitable for selected gas: Minimum gas pressure is determined with boiler operating at high fire and any other appliances connected to same fuel source operational as well (whole house load)
  - Gas A (NG) = 3.5" (8.7 mbar)
  - Gas E (LPG) = 8.0" (19.9 mbar)
- Place supplied label with indication of gas type close to the data plate of boiler replacing the original.
- Perform Automatic Calibration Function - **Section 9.8**.
- Manufacturer recommends verification of CO<sub>2</sub> concentration on the flue.

9.12 Chimney Sweep Function

For correct boiler operation, content of (CO<sub>2</sub> - O<sub>2</sub>) in the combustion flue must be within tolerances indicated in table below.

Combustion Table		Gas A (Natural Gas)						Gas E (LPG)	
		DCBF-75 & 100 DCCF-115 & 150		DCBF-125		DCBF-165 DCCF-205		All	
		CO <sub>2</sub> %	O <sub>2</sub> %	CO <sub>2</sub> %	O <sub>2</sub> %	CO <sub>2</sub> %	O <sub>2</sub> %	CO <sub>2</sub> %	O <sub>2</sub> %
Maximum power (100%)	Nominal value	9.0	4.9	8.7	5.4	9.0	4.9	10.0	5.7
	Permitted value	8.5 – 9.5	4.0 - 5.7	8.2 – 9.3	4.3 – 6.3	8.5 – 9.5	4.0 – 5.7	9.5 – 10.5	4.9 – 6.4
Ignition power (*)	Nominal value	8.7	5.4	8.7	5.4	8.7	5.4	10.8	4.8
	Permitted value	8.2 - 9.3	4.3 – 6.3	8.2 – 9.3	4.3 – 6.3	8.2 – 9.3	4.3 – 6.3	10.3 - 11.3	3.7 – 5.2
Minimum power (0%)	Nominal value	8.8	5.2	8.8	5.2	9.0	4.9	9.8	6.0
	Permitted value	8.2 - 9.3	4.6 – 6.3	8.2 – 9.3	4.3 – 6.3	8.5 – 9.5	4.0 – 5.7	9.3 – 10.3	5.2 – 6.7

(\*) Automatically calculated from the PCB

For correct boiler operation, content of (CO<sub>2</sub> - O<sub>2</sub>) in the combustion flue must be within tolerances indicated in table above.

Chimney Sweep Function enables boiler firing rate to be controlled for diagnostic purposes.

- Press and hold and at the same time for 6 seconds. When the function is enabled, displays shows "On" for few seconds followed by program row "303" alternating with % of boiler power.
- Press or to gradually adjust power (increments of 1%).
- To exit press both buttons and together for at least 6 seconds.
- If value of CO<sub>2</sub>-O<sub>2</sub> is different, check the electrodes and their relative distances. See Figure 11-1.

If necessary, replace electrodes and position them correctly. See Section 11 General Maintenance, Figure 11-1 Electrodes

If problem persists, use "COMBUSTION ADJUSTMENT FUNCTION (CO<sub>2</sub>%)".

If problem continues to persist, follow directions in Section 9.8 Automatic Calibration Function, and Section 9.9 Manual Calibration Function.

**NOTICE**

- Press to display instantaneous flow temperature for 15 seconds.
- Use a regularly calibrated combustion analyzer for combustion analysis.
- During normal operation boiler performs combustion control cycles. In this phase CO values higher than 400 ppm can occur for brief periods of time.

9.13 Combustion Adjustment Function (CO<sub>2</sub>%)

This function sets out to partially adjust the value of CO<sub>2</sub>%. Use the following procedure:

- Press buttons and together for at least 6 seconds. When the function is enabled, displays shows "On" for a few seconds followed by program row "304" alternated with the % of boiler power;
- After burner is lit, boiler shows a flame icon and alternately "304" and current firing power. Press CH+ until "304" & "100" is displayed. It is now possible to partially adjust CO<sub>2</sub> value at 100%.
- If adjustment is needed Press , display shows a blinking flame icon and alternately "304" and "00".
- Press to raise or lower the amount of CO<sub>2</sub> (from -0.3% to +0.3%).
- Press to save new value. Power value "100" will show on display again. Boiler continues operating at maximum DHW power.
- After saving the new value (step 5 above), press to set boiler to ignition power. Wait for value of CO<sub>2</sub> to stabilize. Adjust as described in step 4 of procedure (power value is a number <> 100 and <> 0). Repeat step 5 to save.
- Press to adjust boiler to **minimum power**. Wait for value of CO<sub>2</sub> to stabilize. Go to step 4 to adjust (power value = 00);
- Exit function by pressing and together for at least 6 seconds, see step 1.

## 9 - START UP PROCEDURE

### 9.14 Check Firing Rate

1. Measure input, if a gas meter is installed in the system.
  - Turn off gas to all other appliances.
  - Activate some heating zones to dissipate heat.
  - Set boiler on high fire using Chimney Sweep Function.
  - Use ½, 1 or 2 cu ft dial on gas meter. Measure time required for two or more complete revolutions. Measure time for one or more minutes.
  - Calculate input.

**For Natural Gas :**

$$\text{Input (MBH)} = \frac{3600 \times \text{___ cu ft}}{\text{___ seconds}}$$

Example: Natural Gas - Gas flow from Meter = 2 cu ft

Measured time = 72 seconds

$$= \frac{3600 \times 2 \text{ cu ft}}{72 \text{ seconds}} = 100 \text{ MBH}$$

**For Propane (LP):**

$$\text{Input (MBH)} = \frac{9160 \times \text{___ cu ft}}{\text{___ seconds}}$$

For Metric formulas- See Glossary

2. Compare measured input to table below. If calculated input is not in range given in Table 9-2 check firing rate again after setting the combustion following steps in section 9.12.

### NOTICE










**Important!** Record any changes made to Parameters on chart found on Page 46 of the Application Guide supplied with your boiler.

**Table 9-2 Input Rate @ High Fire (MBH)**

Approximate Rate @ 100% Fire (MBH)	
Size	
75	75
100	93.5
115	115
125	125
150	150
165	164
205	205

### 9.15 Parameter Settings

Program boiler electronic board parameters as follows:

- Press  and  together, hold them down for 6 seconds until program "P01" appears on the display alternated with the set value;
- Press  or  to scroll the list of parameters;
- Press , value of selected parameter begins flashing, press   to change the value;
- Press  to confirm the value or press  to exit without saving.

Further information in regards to parameters listed in the following table are supplied together with required accessories if necessary.



## 9 - START UP PROCEDURE

9.16 Description Of Parameters: Factory Settings		FACTORY SETTINGS		
		75	100,125,165	115,150,205
<b>P01</b>	<b>DHW Fast Modulation</b> 00 = Standard Modulation - on DHW call for heat 10 seconds stabilization time before modulation 01 = Fast Modulation- on DHW call for heat 5 seconds stabilization time before modulation	01		
<b>P02</b>	<b>Gas used</b> 00 = Gas A (Natural Gas) 01 = Gas E (LPG Gas)	00		
<b>P03</b>	Hydraulic system 00 = instantaneous appliance 03 = instantaneous appliance with pre-heat function 04 = heating only appliance with DHW thermostat 05 = appliance with external storage indirect tank 08 = heating only appliance 13 = instantaneous appliance with pre-heat function for solar application	08	00	
<b>P09</b>	Hydraulic Component Setting	Default 01		
<b>P13</b>	Max. heating output (0-100%)	73	100	80
<b>P14</b>	DHW max. output (0-100%)	100		
<b>P15</b>	Min. heating output (0-100%)	00		
<b>P16</b>	Maximum CH set-point (°C) 00 = 176°F (80°C) 01 = 113°F (45°C) <b>Selectable Range 20-80 = (20°C to 80°C) 68°F to 176°F</b>	00		
<b>P17</b>	Pump overrun time in heating mode (01-240 minutes)	03		
<b>P18</b>	Burner on delay with new call for heat (0-10 minutes)	03		
<b>P20</b>	Pump overrun time in DHW mode (seconds)	30		
<b>P21</b>	Anti-legionellosis function 00 = Disabled - 01 = Enabled	00		
<b>P22</b>	Manufacturer information (set "22" to display parameters 42 and above)	00		
<b>P23</b>	Maximum DHW set-point temperature 113°-140°F (45°-60°C), Default 49 = 120°F	49		
<b>P24</b>	Manufacturer information	35		
<b>P26..P31</b>	Manufacturer information	--		
<b>P32..P41</b>	Diagnostics (See SERVICE Instructions)	--		
<b>P44</b>	Temperature unit setting 00 = °C 01 = °F	01		
<b>P67</b>	OT/RT (Open Therm / Room Thermostat) selection. 2=OT (open therm STD)		02	

Parameters continued on next page

## 9 - START UP PROCEDURE

### 9.16 Description Of Parameters: Factory Settings conti.

#### FACTORY SETTINGS

<b>75</b>	<b>100, 125,165</b>	<b>115, 150,205</b>
-----------	-------------------------	-------------------------

The values listed below are factory defaults, there may be differences for each application

Model		75		100		115		125		150		165		205			
Fuel		Natural	LP	Natural	LP	Natural	LP	Natural	LP	Natural	LP	Natural	LP	Natural	LP		
<b>P70</b>	Ignition Fan Speed**	Setting	35	35	35	35	35	35	35	38	38	38	38	44	44	44	44
		RPM	3500	3500	3500	3500	3500	3500	3500	3800	3800	3800	3800	4400	4400	4400	4400
<b>P71*</b>	Maximum Fan Speed**	Setting	85	85	85	85	220	220	115	65	220	170	105	120	225	220	
		RPM	5850	5850	5850	5850	7200	7200	6150	5650	7200	6700	5550	5700	7250	7200	
<b>P72</b>	Minimum Fan Speed**	Setting	50	50	50	50	55	55	40	25	40	35	43	45	40	45	
		RPM	1250	1250	1250	1250	1300	1300	1150	1000	1150	1100	1180	1200	1150	1200	
To calculate fan speeds		(P70 x 100)															
		(P71 x 10) + 5000															
		* For 165 Model: (P71 x 10) + 4500															
		(P72 x 10) + 750															
<b>P73</b>	Boiler Power Selection <b>1</b> = 115 <b>2</b> = 75/100 <b>3</b> = 150 <b>10</b> = 125 <b>11</b> = 205 <b>12</b> = 165													Default depends on firing rate of boiler as listed.			
<b>P74</b>	CH mode burner ignition delay after burner off due to water temperature exceeding limit setting with an interrupted call for heat <b>Range</b> = 0-255 seconds (0-4.25 min.)													0			
<b>P78</b>	<b>0-10V Input</b> <b>0</b> = Disabled <b>1</b> = Temperature Setpoint (3V = minimum setpoint, 10V = maximum setpoint) <b>2</b> = Power Setpoint (3V = minimum power, 10V = maximum power)													0			
<b>P82</b>	<b>4</b> = Disabled <b>3</b> = Enabled 0-10V DC Input													4			

**NOTE :** To scroll to parameter **42 and above** it is necessary to set **P22** to 22 before scrolling up to the parameter.

\*\* See Tables : Section 12.4 -Parameters for High Altitude

**9.17 Adjusting Maximum Heating Power**

Maximum boiler heating power can be reduced to suit requirements of heating system it serves.

Table showing parameter **P13** values according to desired maximum power model is shown for each single boiler.

To access and edit **P13** values, proceed as described in Section 9.15 Parameter Settings.

**Boiler Model - PARAMETER P13 (%) / Heating Output**

Btu/h	kW	DCBF-75	DCBF-100	
16,600	5.0	0	0	0
20,473	6.0	4	4	3
23,885	7.0	7	7	6
27,297	8.0	11	11	9
30,709	9.0	15	15	12
34,121	10.0	18	18	15
40,946	12.0	25	25	21
47,770	14.0	35	35	28
54,594	16.0	45	45	35
61,419	18.0	57	57	45
68,243	20.0	68	68	55
75,067	22.0	73	73	65
81,891	24.0	-	95	75
85,400	25.0	-	100	80

Btu/h	KW	DCBF-125	DCCF-150
20,400	6.0	0	0
23,800	7.0	4	3
27,200	8.0	7	6
30,700	9.0	11	9
34,100	10.0	15	12
40,900	12.0	22	18
47,700	14.0	30	24
54,500	16.0	37	29
61,400	18.0	44	35
68,200	20.0	52	41
75,100	22.0	59	47
81,900	24.0	67	53
88,700	26.0	74	59
95,500	28.0	80	65
102,300	30.0	88	71
109,200	32.0	96	75
112,600	33.0	100	80

Btu/h	kW	DCBF-165	DCCF-205
27,400	8.0	0	0
31,300	9.2	4	3
35,800	10.5	7	6
41,300	12.1	11	9
46,500	13.6	15	12
55,900	16.4	22	18
65,700	19.3	30	24
74,500	21.8	37	29
83,200	24.4	44	35
92,300	27.0	52	41
101,900	29.9	59	47
110,000	32.2	67	53
118,000	34.8	74	59
127,000	37.2	80	65
136,900	40.1	88	71
145,300	42.6	96	75
151,700	44.4	100	80

## FOR YOUR SAFETY READ BEFORE OPERATING

**⚠ WARNING**

**If you do not follow these instructions exactly, a fire or explosion may result causing property damage, personal injury or loss of life.**

- This appliance is equipped with an ignition device which automatically lights burner. **Do NOT try to light this burner by hand.**
- Before operating smell all around appliance area for gas. Be sure to smell next to floor because some gas is heavier than air and will settle to the floor.
- **Use only your hand to turn the gas shutoff valve.** Never use tools. If valve will not turn by hand, do not try to repair it, call a qualified service technician. Force or attempted repair may result in fire or explosion.
- **Do not use this appliance if any part has been under water.** Immediately call a qualified service technician to inspect appliance and to replace any part of control system and any gas control which has been under water.

**⚠ CAUTION****WHAT TO DO IF YOU SMELL GAS**

- Do not try to light any appliance.
- Do not touch any electrical switch; do not use any phone in your building.
- Immediately call your gas supplier from a neighbor's phone. Follow the gas supplier's instructions.
- If you cannot reach your gas supplier, call the fire department.

**10.1 Testing For Gas Leaks And Purging The Gas Supply**

- With boiler gas service valve closed (spindle flats at right angles to valve). Pressure test gas supply and inlet pipe work connection to boiler gas service valve.
- Loosen screw of pressure inlet gas test port on gas valve. See Figure 9-3 Gas Valve. Verify gas supply is ON. Open boiler service valve to purge.
- Retighten test port screw and test for gas leaks. Close boiler gas shutoff valve.

**10.2 Boiler Operation**

Domestic hot water supply always takes priority over central heating.

Demand for hot water required during central heating period, boiler automatically switches to hot water mode until demand is satisfied i.e. storage water is to required temperature.

This interruption in central heating is only when demand for hot water is present and should not be noticed by the User.

**10.3 Central Heating Mode**

1. With demand for heating, pump circulates water through the primary circuit.
2. After a 3 minute anti-short cycling delay the combustion fan comes on at ignition speed, closing the air pressure switch if applicable to model, allowing power to spark generator and gas valve, creating ignition in the combustion chamber.
3. Flame sensor acknowledges presence of flame in combustion chamber sending a signal to the control board.
4. After initial stabilization period the control board monitors supply and return temperatures and modulates fan speed and gas rate accordingly.
5. Once boiler satisfies CH call for heat, the unit will shutdown and enter 3 minute anti-cycling mode. The boiler pump will operate for 3 minutes to dissipate any residual heat. If there is a subsequent CH call for heat, boiler will wait 3 minutes to operate.

**! WARNING**

Burn, Scald Hazard! Water temperature over 125°F (51°C) can cause severe burns and scalding. See User's Manual before setting water temperature. Failure to follow these instructions could result in death or serious injury.

**10.4 Domestic Hot Water Mode****Combi Boilers – Models 115, 150 & 205**

- Domestic hot water call for heat is initiated when a faucet is opened and water flow is sensed by boiler's DHW flow switch.
- 3-way valve diverts boiler water to domestic hot water (DHW) heat exchanger (Braze-plate) to heat incoming domestic water.
- Combustion fan come on at ignition speed, closing the air pressure switch (150 model only), allowing power to flow to the spark generator and gas valve, creating ignition in the combustion chamber.
- Flame sensor senses flame in combustion chamber and sends a signal to the control board.
- Control board monitors boiler water and DHW temperatures, modulates fan speed and gas rate accordingly.
- Domestic call for heat ends when faucet is closed and DHW flow switch does not see water flow.

**Heat Only Boilers – Models 75, 100 & 125 with Indirect Tank**

- When the boiler receives a call for hot water from the Indirect tank Aquastat or Tank Sensor, the 3-Way valve diverts water from the heating system to dedicated Indirect tank supply to heat domestic water in the tank.
- Combustion fan comes on at ignition speed, closing the air pressure switch (125 model only), allowing power to flow to spark generator and gas valve, creating ignition in the combustion chamber.
- Flame sensor will sense flame in combustion chamber and send a signal to the control board.
- Control board monitors boiler water and DHW temperatures and modulates fan speed and gas rate accordingly.
- Call for domestic water heating ends when the aquastat or tank sensor is satisfied.

**Heat Only Boiler 165**

165 boiler does not have a 3-Way Valve. When paired with an Indirect tank, the tank is a separate heat zone. The Indirect tank is controlled by a field supplied multi zone relay, priority is determined by the relay settings.

**10.5 Frost Protection**

Boiler monitors supply and return water temperatures to enable frost protection which automatically turns boiler and pump on.

If water in boiler falls below 41°F (5°C), providing boiler is connected to power, boiler will operate until water temperature in the system reaches approximately 86°F (30°C).

Frost protection is for boiler only and not for complete Central Heating System.

**10.6 Pump**

If electricity is connected to the boiler, regardless if power is "On" or "Off" and has not operated for 24 hours for heating or hot water, boiler pump will operate automatically for one minute every 24 hours.

**10.7 Low Water Pressure Sensor (Internal)**

This device protects primary exchanger from damage. It will not allow boiler to run in a LOW water pressure situation. Low water condition occurs when water pressure drops below 7.0 psi (0.5 bar).



### ⚠ DANGER

Before servicing, turn off electrical power to boiler at service switch. Close manual gas valve to turn gas supply OFF to boiler. Failure to comply will result in death or serious injury.

### ⚠ CAUTION

Label all wires prior to disconnection when servicing controls. Wiring errors can cause improper and dangerous operation.

#### Note

Verify proper operation after servicing.

#### Note

Perform regular service and maintenance by qualified service agency at least once every 12 months to assure safe, trouble free operation and maximum efficiency.

#### Note

A Heat Exchanger cleaning kit is available for annual service of the boiler. See repair parts manual for part number.

### 11.1 Beginning of Each Heating Season

- Check boiler area is free from combustible materials, gasoline, and other flammable vapors and corrosive liquids.
- Visually inspect combustion air and vent piping for proper operation. Check for and remove any obstruction to flow of combustion air or vent gases. Immediately repair or replace pipe showing deterioration or leakage. Reassemble per instructions in section 5. Ensure proper reassembly and resealing of system.
- Visually inspect condensate drain line for proper operation. Checking for deteriorated or plugged condensate drain line. Verify condensate trap drains freely and clean as required.
- Test safety relief valve for proper operation. Refer to valve manufacturer's instructions packaged with relief valve.
- Examine heat exchanger, burner, condensate lines, and clean (if necessary) by following instructions in section 11.3 - Component Replacement And Cleaning.

- Circulator pump and combustion air blower motor furnished with boiler are permanently lubricated from factory and require no further lubrication. Lubricate field sourced pumps and/or motors according to pump and/or motor manufacturer's instruction.
- Check following components are operating properly and are free of blockages or obstructions:
  - air vent;
  - check venturi air inlet for blockage and clean as required;
  - verify pressure test port cap and combustion test port caps are in place;
  - verify supply and return sensors are properly clipped to pipes as close to heat exchanger as possible;
  - Check boiler for any sign of leaks.
- Check external low water cutoff operation (if installed).
  - Check operation by pressing test button on low water cutoff.
    - "Low Water" LED on the external LWCO should illuminate and boiler should shut down.
  - Every 5 years remove low water cutoff. Reinstall after cleaning.
  - Every 10 years replace low water cutoff.
- Visual inspection of flame through sight glass. Burner should be fully illuminated.
- Check heating system expansion tank.

**⚠ WARNING**

Following service procedures must be performed by qualified service agent. Boiler owner shall not attempt these steps. Failure to do so could result in death or serious injury.

**⚠ WARNING**

Combustion chamber insulation in this product contains ceramic fiber material. Ceramic fibers can be converted to cristobalite in very high temperature applications. The International Agency for Research on Cancer (IARC) has concluded, Crystalline silica inhaled in the form of quartz or cristobalite from occupational sources is carcinogenic to humans (Group1). Avoid breathing dust and contact with skin and eyes. Use NIOSH certified dust respirator (N95). This type of respirator is based on the OSHA requirements for cristobalite at the time this document was written. Other types of respirators may be needed depending on the job site conditions. Current NIOSH recommendations can be found on the NIOSH website <http://www.cdc.gov/niosh/homepage.html>. NIOSH approved respirators, manufacturers, and phone numbers are also listed on this website. Wear long-sleeved, loose fitting clothing, gloves, and eye protection. Apply enough water to the combustion chamber lining to prevent dust. Wash potentially contaminated clothes separately from other clothing. Rinse clothes washer thoroughly. NIOSH stated First Aid. Eye: Irrigate immediately. Breathing: Fresh air.

**⚠ WARNING**

Before servicing, turn off electrical power to boiler at service switch. Close manual gas valve to turn gas supply OFF to boiler. Test for gas leaks on any gas carrying components after servicing. Service not complete until appliance operation verified per Installation, Operation & Maintenance Manual provided with boiler.

**⚠ CAUTION**

Label all wires prior to disconnection when servicing controls. Wiring errors can cause improper and dangerous operation. Failure to follow these instructions could result in minor or moderate injury.

**NOTICE**

Perform regular service and maintenance by qualified service agency at least once every 12 months to assure safe, trouble free operation and maximum efficiency.

**11.2 Maintenance And Routine Servicing**

Check and service boiler as necessary.

Frequency of servicing will depend upon installation conditions and usage, manufacturer recommends annually.

- Check combustion is correct using combustion analyzer.
- Check flue terminal outside and ensure it is not blocked.
- Operate boiler. Check operation of boiler's controls.
- Ensure all system connections and fittings are sound. Correct any joints and fittings that maybe leaking.
- Follow safety valve manufacturer recommendations for service.

To ensure boiler operates at peak efficiency, following checks must be performed every year:

- check appearance and tightness of gas and combustion circuit gaskets
- check condition and position of ignition and flame sensing electrodes
- check condition of burner and its connection to aluminum front plate
- check for dirt in combustion chamber. Use vacuum cleaner for this cleaning operation
- check gas valve is calibrated correctly using combustion analyzer
- check there is no dirt in condensate trap
- check central heating system pressure
- check expansion tank pressure
- check vent system, clean if necessary

Record details and maintain service history.

**11.3 Component Replacement And Cleaning**

1. Remove any deposits from heat exchanger using suitable soft brush. *Do not* use brush with metallic bristles.
2. Check condition of the combustion chamber insulation panels. Any damaged panels must be replaced.
3. Check condition of burner. Clean burner with soft brush and check flame ports are clear. Blockages may be removed with stiffer brush. Do not use a brush with metallic bristles this might damage the burner.
4. Remove any fallen deposits from bottom of inner case.
5. Check condition of electrodes.
6. Check spark gap, positioning and height of electrodes.
7. Check fan impeller is clean and free to rotate.

**AFTER ANY COMPONENT REPLACEMENT OR CLEANING AUTO CALIBRATION IS REQUIRED.**

**⚠ DANGER**

Before servicing, turn off electrical power to boiler at service switch. Close manual gas valve to turn gas supply OFF to boiler. Failure to comply will result in death or serious injury.

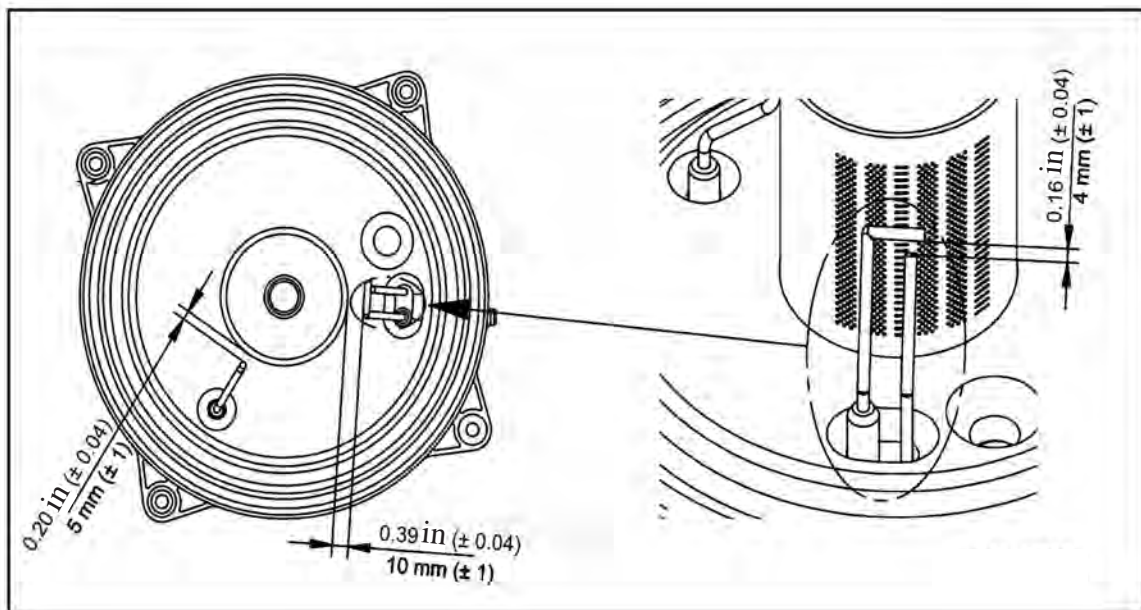
**11.4 Draining the Boiler**

- turn boiler off
- isolate electrical supply
- close boiler gas service cock
- allow boiler to cool
- drain boiler through onboard drain if available or external drain valve.

**11.5 Draining the Heating Circuit**

- Follow all steps in 11.4.
- Close central heating flow and return valves.
- Connect suitable pipe to drain point.
- Route it to suitable container.
- Open drain tap.

**11-1 ELECTRODES**



## 11 - GENERAL MAINTENANCE AND CLEANING

### 11.6 Hydraulic Unit (DHW)

For special areas, where water is harder than 200 ppm or 12 grains/ gallon, install polyphosphate dispenser or equivalent treatment system, compliant with current regulations.

### 11.7 Cleaning The Cold Water Filter

Boiler is fitted with cold water strainer located on DHW hydraulic assembly (B). To clean:

- Drain domestic hot water system. (C - 115 & 150)
- 165 Drain is field supplied/installed.
- Remove nut on DHW priority sensor unit using 18 mm wrench. (B)
- Pull out flow sensor and its filter.
- Soak in white vinegar or replace as necessary.

### NOTICE

When replacing and/or cleaning "O-rings" on hydraulic assembly (DHW), use only Molykote 111 as a lubricant, not oil or grease.

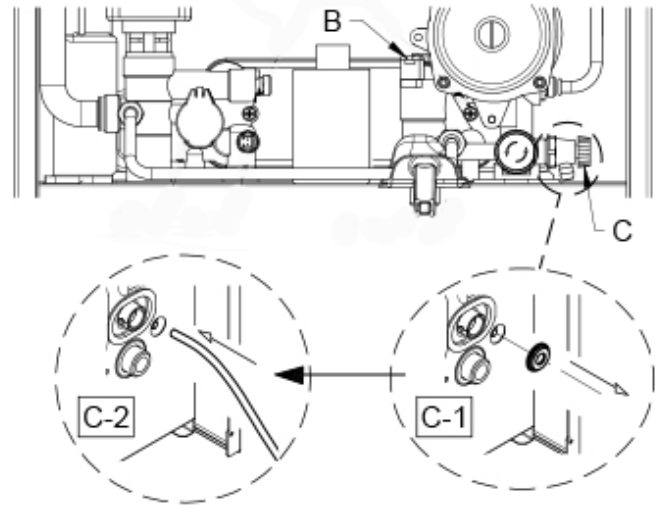
### 11.8 Final Commissioning

- Allow heating system to heat. Balance the system to achieve temperature difference across heating supply and return pipes at the boiler.
- Check system for proper volume and pressure. See page 4 for acceptable volume and pressure.
- Turn off boiler.
- Thoroughly flush water pipe work. Clean filters in heating return and supply water isolating valves.
- Repressurize the system.

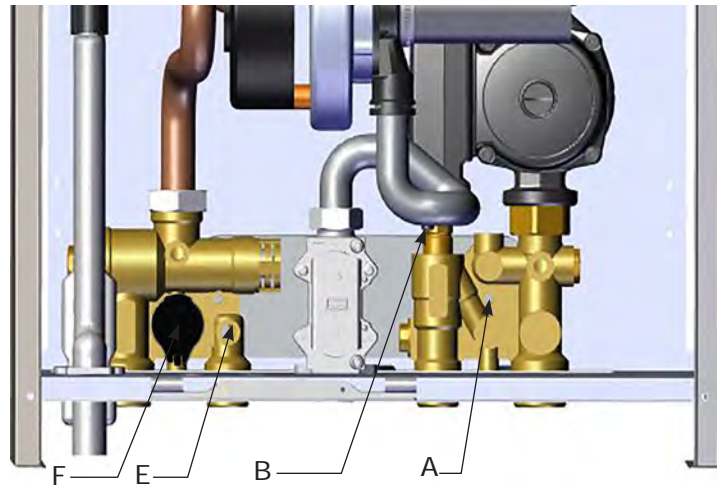
### 11.9 Final Assembly

- Place front jacket in position over boiler. Secure in position using screws previously removed.
- If boiler is to be left in service, set controls and room thermostat.
- If boiler is not to be handed over immediately, close boiler gas service valve and turn off electrical supply.
- If there is possibility of boiler being left during frost conditions drain boiler and system. See section 11.4 Draining the boiler. Manufacturer recommends attaching a label to the boiler drawing attention to the fact that the system has been drained.

### Model DCCF-115 & 150



### Model DCCF-205



#### LEGEND

#### Hydraulic Assembly (B)

<b>A</b>	DHW Exchanger Fixing Screw
<b>B</b>	DHW Priority Sensor With Filter
<b>C</b>	Boiler/System Drain Tap (150 Unit Only) <i>(C-1 &amp; C-2: Access To Tap C - Bottom Of Boiler)</i>
<b>D</b>	Boiler / System Filling Tap (150 Unit Only)
<b>E</b>	DHW Temperature NTC Probe
<b>F</b>	Low Water Cutoff


### 11.10 User Information

Advise and demonstrated to User the following important information:

- A. How to light and turn off boiler. How to operate system controls.
- B. Importance of annual servicing of boiler to ensure safe and efficient operation.
- C. Servicing or replacement of parts shall be carried out by a qualified personnel.
- D. Ensure boiler controls and room thermostat, if fitted, are set to User's requirements.
- E. Explain to User an internal frost thermostat is fitted in boiler, and electrical supply to boiler must be left on for thermostat to operate.
- F. Show User position of pressure relief valve discharge pipe.
- G. Leave this Installation, Operation and Maintenance Manual with User.

### 11.11 Safety Flue Thermostat - *DO NOT disable this safety device.*

Safety Flue Thermostat found on the flue inside the boiler, interrupts flow of gas to the burner if the temperature overheats.

After verifying the cause of the trip, press  for about 2 seconds.

### 11.12 Flue Pressure Switch (125-150 Only) *DO NOT disable this safety device.*

This device, positioned inside the sealed chamber, interrupts flow of gas to the burner if flue pressure exceeds 1.6 in w.c. (4 mbar). Verify if vent is blocked before resetting the boiler.

### NOTICE

When servicing the appliance, check the condition and position of flame sensing electrode and replace it if necessary.

### 11.13 Replacement Parts

Perform Automatic Calibration procedure described in section 9.8 if one or more of the following components are replaced. Check and adjust CO<sub>2</sub>% value as indicated in the Combustion Table.

Components replaced:


- Primary heat exchanger
- Fan
- Gas valve
- Gas orifice
- Burner
- Flame sensing electrode
- Spark electrode



## 12 - RATINGS AND CAPACITIES

### 12 TECHNICAL DATA

#### 12.1 Ratings and Capacity

					
Model Number	CH Input, MBH <sup>(1)</sup>		<sup>(1)(2)</sup> CH Heating Capacity, MBH *	<sup>(1)(3)</sup> Net AHRI Rating Water, MBH	<sup>(2)</sup> AFUE%
	Maximum	Minimum			
DCBF-75	75	16.6	68.2	60	92.0
DCBF-100	93.5	16.6	85.4	74	95.0
DCCF-115	93.5	16.6	85.4	74	95.0
DCBF-125	125	22	113	98	95.0
DCCF-150	125	22	113	98	95.0
DCBF-165	164	29.5	153	133	95.0
DCCF-205	164	29.5	153	133	95.0

(1) 1000 Btu/hr (British Thermal Units Per Hour)  
 (2) Heating Capacity and AFUE (Annual Fuel Utilization Efficiency) are based on DOE (Department of Energy) test procedures.  
 (3) Net AHRI Ratings based on piping and pickup allowance of 1.15. Contact Technical Support before selecting boiler for installations having unusual piping and pickup requirements, such as intermittent system operation, extensive piping systems, etc.

\*Max CH Supply temp 176° F (80°C)

#### 12.2 Domestic Hot Water Specifications

Item		DCCF-115	DCCF-150	DCCF-205
Input Ratings (MBH)	Min	16.6	22	29.5
	Max	115.5	153	205
Output Ratings (MBH)	Min	15.3	19	26
	Max	105.5	136	180
Domestic Water Pressure		2.9 psi (0.2 bar) - 116 psi (8.0 bar)		
Minimum Flow Rate		0.55 GPM	0.50 GPM	
Maximum Flow Rate		2.64 gpm	3.50 gpm	5.00 gpm
Flow Rate 77°F (43°C) Temp. Rise		2.35 gpm	3.25 gpm	4.65 gpm
DHW Supply Connection Size		1/2"BSPT at boiler or 1/2" Copper Sweat**	1/2" NPT	3/4" NPT
Cold Water Input Connection Size			1/2" NPT	3/4" NPT

\*Max DHW temp 140° F (60° C)

\*\*1/2" Copper stub adapters included with boiler

## 12 - RATINGS AND CAPACITIES

### 12.3 High Altitude Ratings

For elevations between 2000 ft (600 m) and 10,000 ft (3048 m), use the following information:

Altitude	Model Number	Input, MBH (KW)		Heating Capacity, MBH*	AFUE, %	Domestic Hot Water (DHW) Circuit**			
		Maximum	Minimum			Max Input, MBH	Min Input, MBH	Max Output, MBH	Min Output, MBH
2,000-4,500 ft (600m-1350m)	DCBF-75	69.5	16.5	62.7	92.0				
	DCBF-100	88.8	16.5	81.1	95.0				
	DCCF-115	88.8	16.5	81.1	95.0	109.7	16.6	100.2	15.3
	DCBF-125	113	22	101	95.0				
	DCCF-150	113	22	101	95.0	137	22	122	19
	DCBF-165	147	26.5	137	95.0				
	DCCF-205	147	26.5	137	95.0	184.5	26.5	157	23
4,501-6,500 ft (1372 m -1981 m)	DCBF-165	135	24.1	126	95.0				
	DCCF-205	135	24.1	126	95.0	168	24.1	143	20
6,501-10,000 ft (1982 m -3048 m)	DCBF-165	113	20.3	105	95.0				
	DCCF-205	113	20.3	105	95.0	141	20.3	120	17
* Max CH Supply temp 176° F (80° C) for DCBF-125 and DCCF-150						** DCCF-150 Max DHW Flow rate 3.5 gpm (13.2 l/min)			
* Max DHW temp 140° F (60° C)						**DCCF-205 Max DHW flow rate 5.0 gpm (18.9 L/min)			

### 12.4 High Altitude Chart

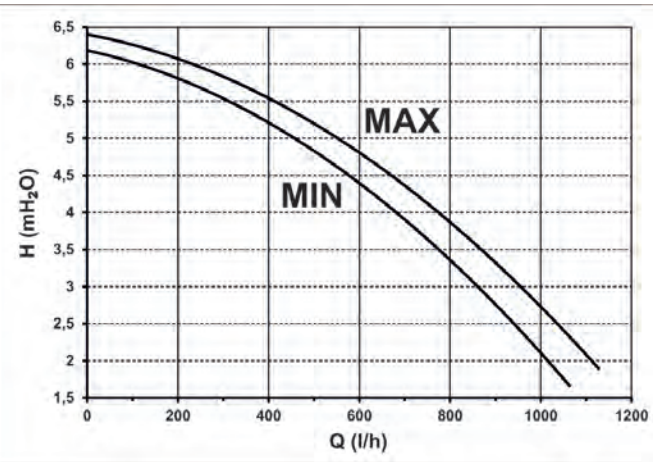
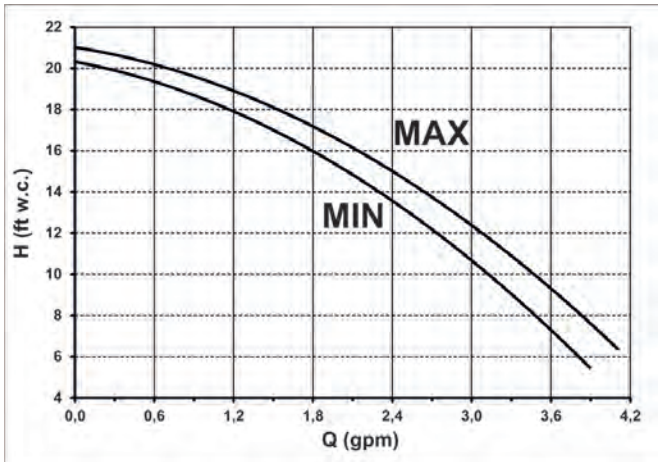
	GAS		Natural		LP	
	Model		Altitude			
			0-2,000 ft. [0-610 m]	2,000- 10,000 ft [610-3,048 m]	0-2,000 ft. [0-610 m]	2,000- 10,000 ft [610-3,048 m]
Parameter P71 High Fire Fan Speed	75	Setting RPM	75 4,600	52 4,500	75 4,600	52 4,600
	100	Setting RPM	85 5,350	75 5,250	85 5,350	75 5,250
	115	Setting RPM	220 7,200	190 6,900	220 7,200	190 6,900
	125	Setting RPM	115 6,150	60 5,600	65 5,650	40 5,400
	150	Setting RPM	220 7,200	170 6,700	170 6,700	150 6,500
	165	Setting RPM	105 6,050		120 6,200	
	205	Setting RPM	225 7,250		220 7,200	
Parameter P72 Low Fire Fan Speed	75 & 100	Setting RPM	50 1,250		70 1,450	
	115	Setting RPM	55 1,300		55 1,300	
	125	Setting RPM	40 1,150		25 1,000	
	150	Setting RPM	40 1,150		25 1,000	
	165	Setting RPM	43 1,180	60 1,350	45 1,200	60 1,350
	205	Setting RPM	40 1,150	60 1,350	45 1,200	60 1,350

CO Limit < 200 ppm

**12.5 Available Boiler Pump Head g**

This is a high static head pump fit for installation on any type of single or double-pipe heating systems. The automatic air valve incorporated in the pump allows quick venting of the heating system.

Q	WATER FLOW RATE	MIN	Minimum speed of modulation
H	HEAD	MAX	Maximum speed of modulation



## 13 - TROUBLE SHOOTING

### 13.1 Error Messages And Resetting The Boiler

<b>E</b>	<b>Error Description</b>	<b>Operation</b>
<b>09</b>	Gas valve connection fault	Check cable PCB/gas valve and gas valve plug
<b>10</b>	Outdoor sensor fault	Check sensor and cable
<b>15</b>	Gas valve command fault	Verify all cables. Replace PCB.
<b>20</b>	Central Heating NTC sensor fault	Check sensor and cable
<b>28</b>	Flue NTC heat exchanger sensor fault	Check sensor and cable
<b>40</b>	Return NTC sensor fault	Check sensor and cable
<b>50</b>	Domestic Hot Water NTC sensor fault	Check sensor and cable
<b>53</b>	Obstruction in flue pipe, Recirculation, Out of Calibration, Poor gas quality	Check for obstruction in flue pipe. Check gas pressure, check gas orifice. Check for recirculation, recalibrate, check gas quality.
<b>55</b>	PCB not programmed	Follow instructions provided with control board replacement kit, call technical service for assistance.
<b>E72/E92</b>	<b>R</b> Combustion test alarm during commissioning / calibration	Check flame sensor, check for obstruction in flue pipe, check for recirculation, check gas pressure, check gas orifice, check gas quality. Perform automatic calibration function and manual calibration function if necessary.
<b>78</b>	Minimum gas valve IMOD current	Check gas supply pressure Check the correct position and integrity of the sensing electrode Check and clean the igniter and sensing electrode if necessary Check flue recirculation Check Combustion is within specifications in IOM Auto calibrate, manual calibrate if necessary Replace components if all else fails
<b>79</b>	Maximum gas valve IMOD current	
<b>E83</b>	OT Communication Failure	Check OT connection, remove power, reconnect OT connections, if problem persists replace service key.
<b>84-85 86-87</b>	Communication problem between boiler board and control unit	Probable short circuit on wiring. Check cable between control unit and boiler
<b>109</b>	Pre-circulation alarm (temporary fault)	Check correct circulation of water and pump. Check supply and return wiring is correct.
<b>110</b>	<b>R</b> Safety thermostat tripped due to over temperature (pump probably blocked or air in heating circuit)	Check safety thermostat and cable; check correct circulation of water and pump
<b>118</b>	Hydraulic pressure too low.	Refill heating system by opening cold water tap
<b>117</b>	Hydraulic pressure too high.	Relieve pressure via relief valve or drain. Ensure water feed is operating correctly.
<b>125</b>	<b>R</b> No circulation of water (control performed via temperature sensor).	Check correct circulation of water and pump. Check correct connection of NTC sensor on pipe
<b>128</b>	<b>R</b> Loss of flame 8 consecutive times after flame proving stage.	Check sensing electrode and cable, flue recirculation, electrical continuity between burner and ground, gas pressure, gas orifice. Perform automatic calibration and manual calibration function if necessary.
<b>130</b>	<b>R</b> NTC flue sensor tripped due to over temperature	Check thermostat, correct circulation of water and pump. Check status of primary exchanger.
<b>131</b>	<b>R</b> Thermo fuse tripped due to over temperature or wire harness disconnected from thermo fuse, off the board, or wire harness may be cut.	Check thermo fuse, correct circulation of water and pump. Check status of primary exchanger. Replace heat exchanger. Verify wire harness installation and continuity.
<b>133</b>	<b>R</b> Ignition failure	Check correct operation of condensate trap. Check sensing electrode, spark electrode and cable. Check flue recirculation, electrical continuity between burner and ground. Check gas orifice and gas pressure. Perform automatic calibration and manual calibration function if necessary.
<b>134</b>	<b>R</b> Gas supply valve blocked	Check gas pressure, sensing electrode, spark electrode and cable, replace PCB if it necessary.

13.1 Error Messages and Resetting the Boiler - continued

<b>E</b>	Error Description	Operation
<b>135</b>	Internal error	Verify all cables. Replace PCB.
<b>160</b>	Fan fault	Check fan and cable
<b>162/317</b>	Incorrect power supply frequency.	Incorrect power supply frequency.
<b>169</b>	Flue pressure switch (contact open)	Check pressure switch and cable. Check obstruction on flue pipe
<b>164/384</b>	<b>R</b> Fault flame (parasitic flame).	Check correct operation of T. gas valve.
<b>165/385</b>	Input voltage too low.	Check power supply
<b>E178</b>	Low return water temperature / anti-freeze function active	Check the return water sensor, check the circulator, check the correct circulation of the water. Boiler will exit status when condition is resolved.

To RESET **R** boiler press  button for at least 2 seconds.

For other error codes not described in table please contact manufacturer at 1(800) 325-5479.

<b>Anomalies Only Displayed in the Fault History</b>		
<b>E62</b>	Anti-wind activation with increase of the minimum fan speed	Check the position of the terminal of the flue duct.
<b>E63/E65</b>	Combustion level out of range	Check flue recirculation and combustion levels.
<b>E65</b>	Maximum value of the speed reached / correction of the flame signal	Check flue recirculation on the flue duct.
<b>E67</b>	Anti-wind activation at maximum power	Check the position of the terminal of the flue duct.
<b>E69</b>	Combustion level out of range	Check flue recirculation and the combustion levels.
<b>E70</b>	Flame signal problem/micro interruption of the flame signal	Check cable and integrity of the sensing electrode, verify the continuity between burner and earth.
<b>E73</b>	Combustion adjustment / modified during operation	Review and monitor other codes such as <b>E53</b> and <b>E92</b>



## 13 - TROUBLE SHOOTING

**13.2 Anomalies Table for the Installer** - Use this table to report the anomaly values.

FAILURE CODE	NUMBER OF TIMES OCCURRED	TEMPERATURE
--------------	--------------------------	-------------

SYSTEM STATUS CODES 0 STANDBY 1 DHW "ON" 2 CHIMNEY SWEEP ACTIVE 3 CH "ON" 4 PREHEAT "ON" 5 CH NO FROST "ON" 6 DHW NO FROST "ON" 8 THERMOSTATIC POST- CIRCULATION
--

		Anomaly Number	Anomaly Code	Consecutive Counter for the Same Anomaly	Number of Days Elapsed From the Anomaly Event	System Status	Phase Status	CH Flow Temperature Value During the Anomaly vent
<b>NO RESET ANOMALY</b>	P32	C00						
	P33	C01						
	P34	C02						
	P35	C03						
	P36	C04						
	P37	C05						
<b>RESET ANOMALY</b>	P38	C06						
	P39	C07						
	P40	C08						
	P41	C09						

C00: LAST FAILURE  
C06: FIRST FAILURE  
C07: LAST LOCKOUT  
C09: FIRST LOCKOUT

PHASE STATUS CODES  
0: STANDBY  
1: PREPURGE  
3: INTERPURGE  
4: SAFETY TIME  
5: RUNNING  
6: LOCKOUT  
11: INTERURGE  
15: POST VENTILATION  
16: THERMOSTATIC POST VENTILATION

## 14 - GLOSSARY

- **APPLIANCE** - Device to convert gas into energy; term includes any component, control, wiring, piping or tubing required to be part of the device.
- **ANSI** - American National Standards Institute, Inc. oversees the creation and maintenance of voluntary consensus standards, including ANSI Z21.13/CSA 4.9: Gas-Fired Low Pressure Steam and Hot Water Boilers.
- **ASME - Association of Mechanical Engineers**  
Establishes rules of safety governing the design, fabrication, and inspection of boilers and pressure vessels, determining the MAWP of such vessels.
- **ASTM** - American Society for Testing and Materials. ASTM International is one of the largest voluntary standards development organizations in the world, trusted source for technical standards for materials, products, systems, and services. Known for their high technical quality and market relevancy, ASTM International standards have an important role in information infrastructure that guides design, manufacturing and trade in the global economy.
- **AUTHORITY HAVING JURISDICTION** - Individual or organization adopting and enforcing codes, rules, and by-laws governing various concerns of a community. Commonly referred to as "final authority" for any matters relating to LIFE SAFETY and BUILDING CONSTRUCTION within a community.
- **BOILER** - Appliance intended to supply hot liquid for space-heating, processing or power purposes.
- **BTU** - Abbreviation for British Thermal Unit. Quantity of heat required to raise the temperature of 1 pound of water 1°F.
- **BURNER** - Device for final conveyance of gas or mixture of gas and air, to the combustion zone.
- **CALIBRATE** - Make fine adjustments or divide into marked intervals for optimal measuring.
- **COAXIAL VENTING** - Sharing the same center.
- **COMBUSTION** - Rapid oxidation of fuel gases accompanied by production of heat or heat and light. Complete combustion of fuel is possible only in the presence of an adequate supply of oxygen.
- **COMBUSTIBLE MATERIAL** - Materials made of or surfaced with wood, compressed paper, plant fibers, or other materials capable of being ignited and burned. Such material shall be considered combustible even though flame-proofed, fire-retardant treated, or plastered.
- **COMBUSTION AIR** - Air that is drawn into an appliance to mix with fuel and support combustion.
- **CONDENSATE** - Liquid separated from flue gas due to reduction in temperature.
- **DIRECT VENT BOILER** - Boiler constructed and installed so all combustion air is derived directly from outdoors and all vent gases are discharged to outdoors.
- **DOMESTIC** - Relating to household usage as opposed to commercial usage.
- **DOMESTIC WATER** - Potable drinking water - tap water.
- **DRAFT** - Pressure difference causes gases or air to flow through a chimney, vent, flue or appliance.
- **FLA** - Full load amps.
- **FLUE** - Enclosed passageway for conveying combustion gases.
- **FLUE GASES** - Products of combustion plus excess air in appliance flues or heat exchanger.
- **GAS SUPPLIER** - Party that sells commodity of Natural Gas (Gas A) or LPG (Gas E).
- **HIGH-VOLTAGE** - Circuit involving potential of not more than 600 volts and having circuit characteristics in excess of those of low-voltage circuit.
- **HYSTERESIS (DIFFERENTIAL)** - Difference between the temperature at which the thermostat switches off - and the temperature at which it switches on again.
- **IGNITER** - Device utilizing electrical energy to ignite gas at main burner.
- **LEAK CHECK** - Operation performed on gas piping system to verify system does not leak.
- **LICENSED QUALIFIED INSTALLER / SERVICE TECHNICIAN** - Any individual, firm, corporation or company that either directly or through a representative is engaged in the installation, replacement, repair or servicing of gas piping, venting systems, appliances, components, accessories, or equipment, and whose representative is experienced and trained in such work and has complied with the requirements of the authority having jurisdiction.
- **LOW WATER CUTOFF** - Device constructed to automatically cut off fuel supply when surface of water in boiler falls to lowest safe water level.
- **LOW-VOLTAGE** - Circuit involving potential of not more than 30 volts.

- **METRIC GAS METERS**

**Natural Gas**

$$\text{MBH} = \frac{127,116 \times \text{cu meters}}{\text{Seconds}}$$

For example: Gas Meter measures 0.1 cubic Meters in 100 seconds

$$\text{MBH} = \frac{127,116 \times 0.1}{100} = 127 \text{ MBH}$$

**Propane Gas (LP)**

$$\text{MBH} = \frac{383,482 \times \text{cu meters}}{\text{Seconds}}$$

- **NATIONAL BOARD OF BOILER AND PRESSURE VESSEL INSPECTORS** - Group composed of boiler and pressure vessel inspectors representing states, cities and provinces enforcing pressure equipment laws and regulations.

- **PRESSURE TEST** - Operation performed to verify gas tight integrity of gas piping following its installation or modification.

- **PURGE** - To free gas conduit of air or gas, or mixture of gas and air.

- **PURGE TIME** - Period of time intended to allow for dissipation of any unburned gas or residual products of combustion.

- **QUALIFIED AGENCY** - Any individual, firm, corporation, or company engaged in and responsible for:

- Installation, testing, or replacement of gas piping, or connection, installation, testing, repair or servicing of appliances and equipment.
- Experienced in such work.
- Familiar with all precautions required.
- Complies with all requirements of authority having jurisdiction.

- **SAFETY RELIEF VALVE** - Valve designed to relieve pressure in hot water supply system when pressure exceeds pressure capability of equipment.

- **SAFETY SHUTOFF DEVICE** - Device that will shut off gas supply to controlled burner in event source of ignition fails.

- **SEDIMENT TRAP** - Gas piping arrangement designed to collect any liquid or solid contaminant before reaching gas valve.

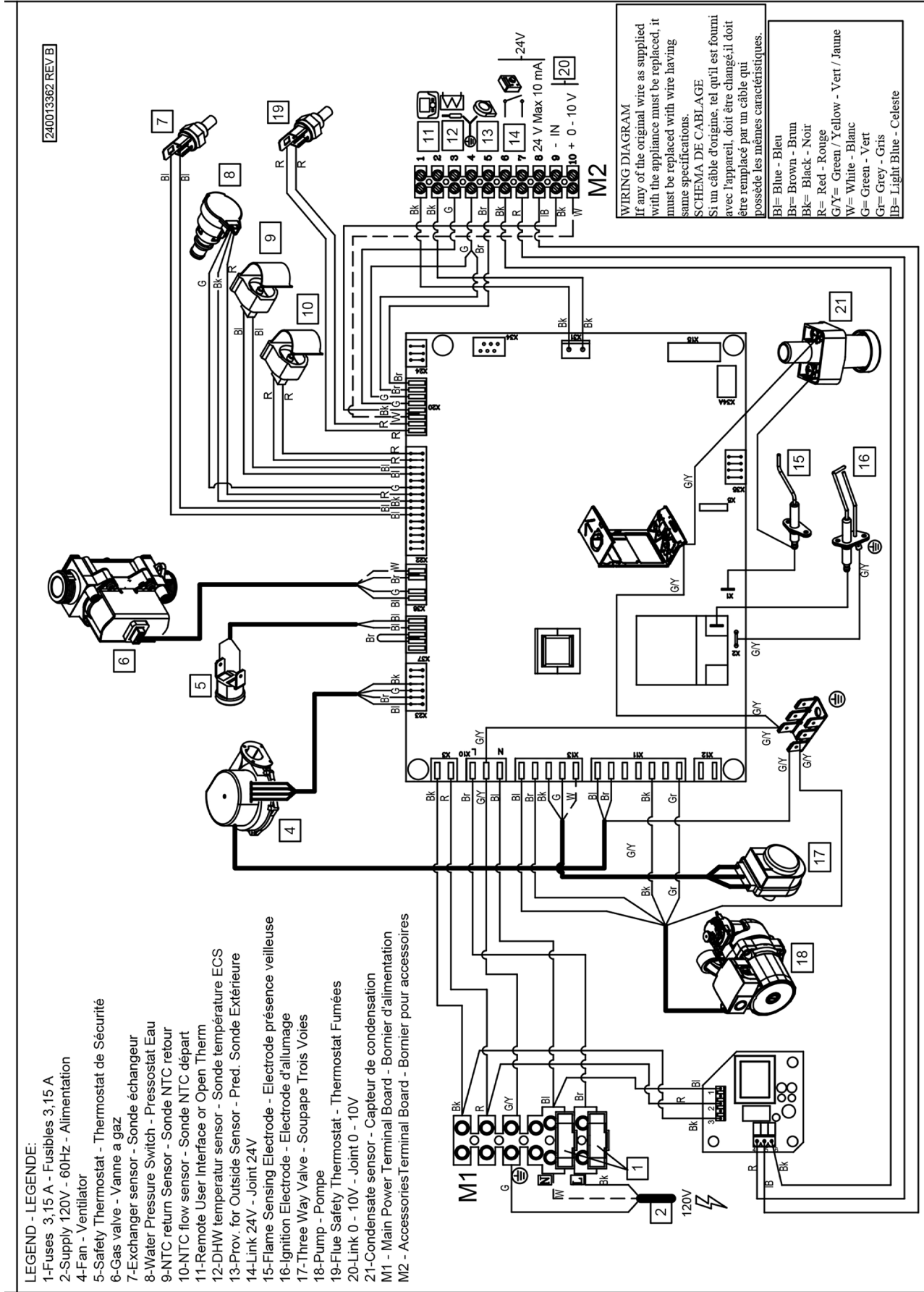
- **SERVICE** -Supply, installation, or maintenance of goods carried out by a Qualified Installer / Service Technician.

- **TWO PIPE SYSTEM** - Type of venting that allows for exhaust flue and intake air piping to be separated from each other. Fresh air may be drawn in at a different area from where flue terminal is located.

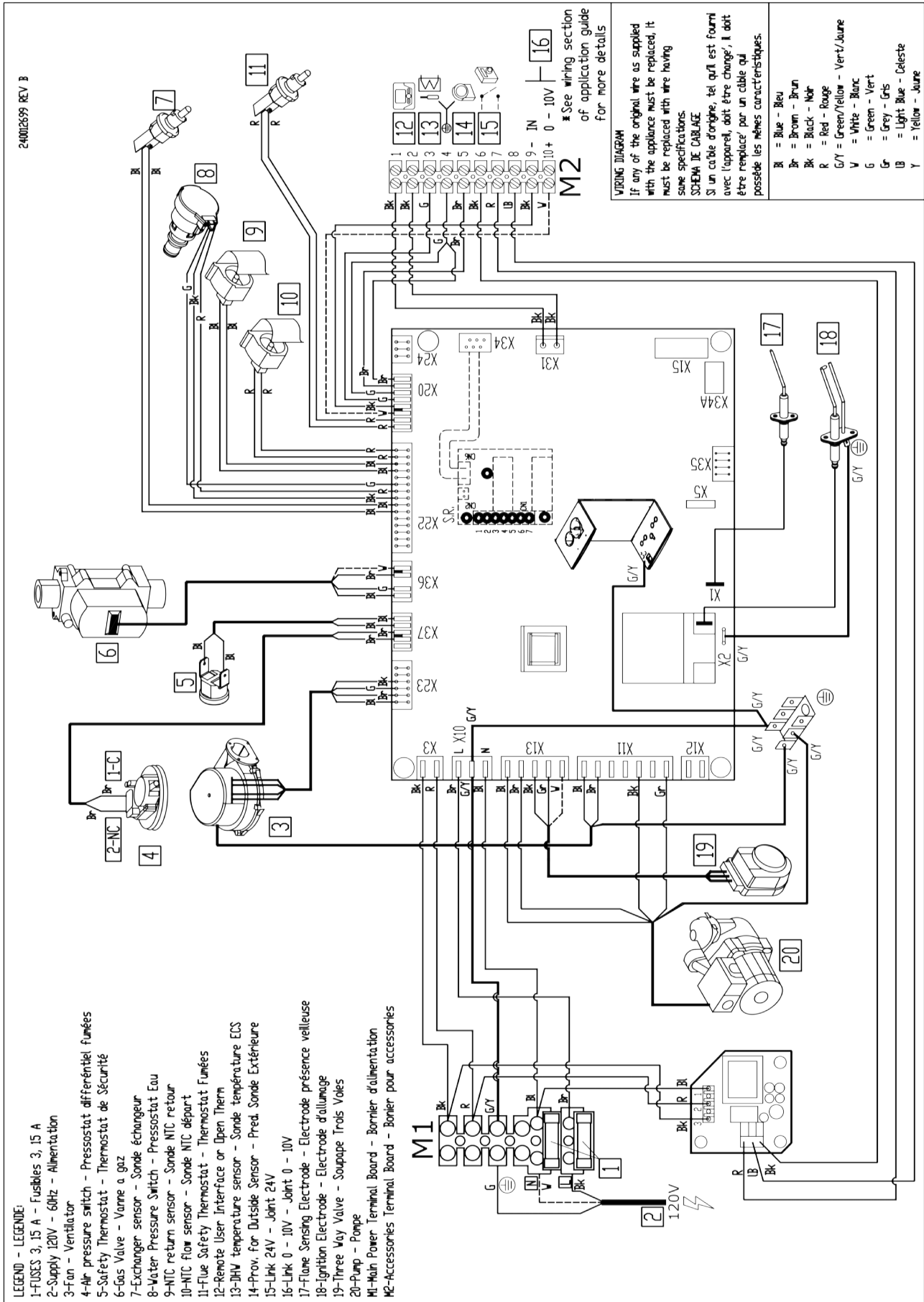
- **VENT** - Passageway used to convey flue gases from appliance vent connector to outdoors.

- **VENTING SYSTEM** - Continuous open passageway from of appliance vent connector to outdoors for purpose of removing flue or vent gases.

A-1 MODEL 75 & 100 - Heat Only

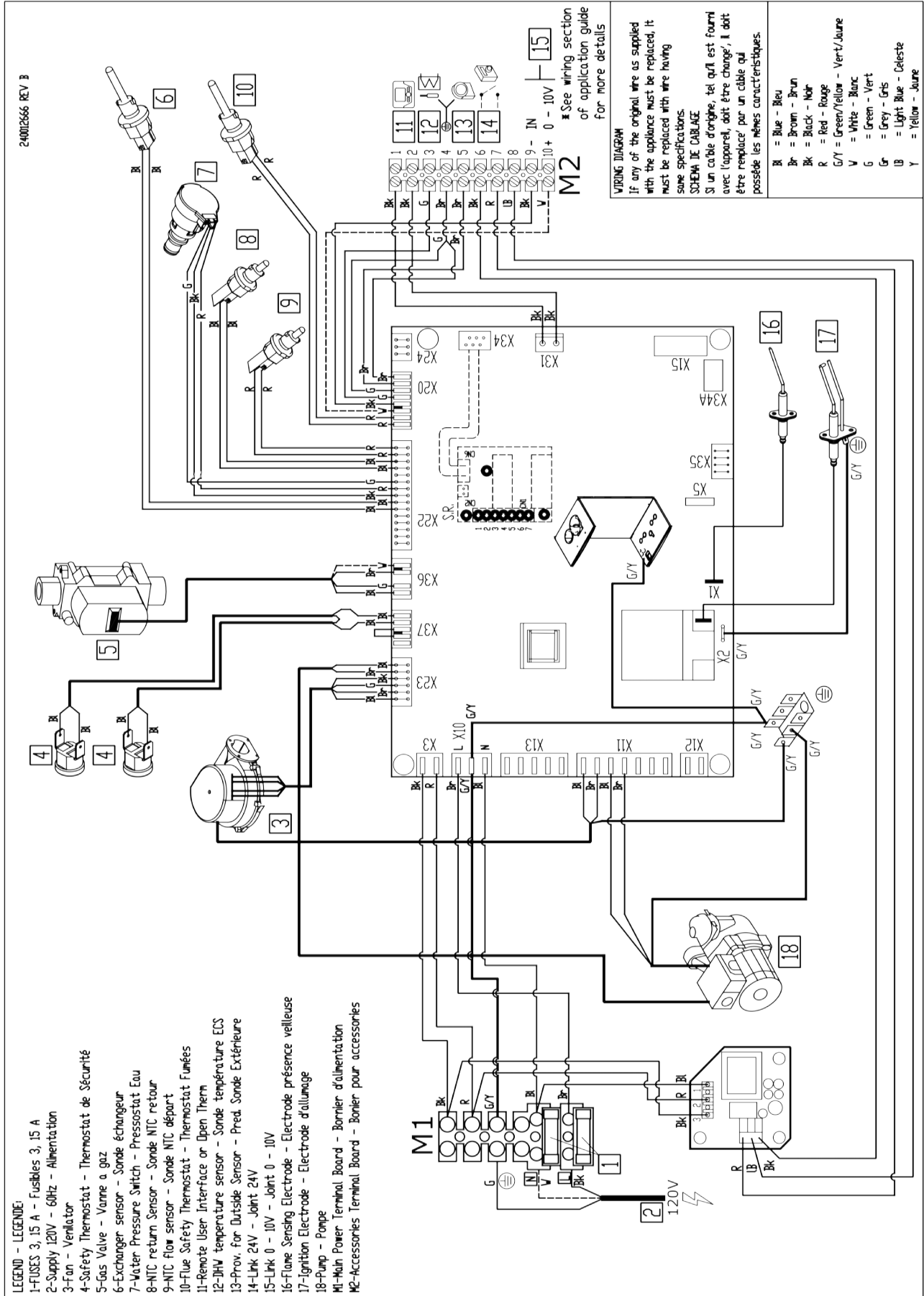


A-2 MODEL 125 - Heat Only

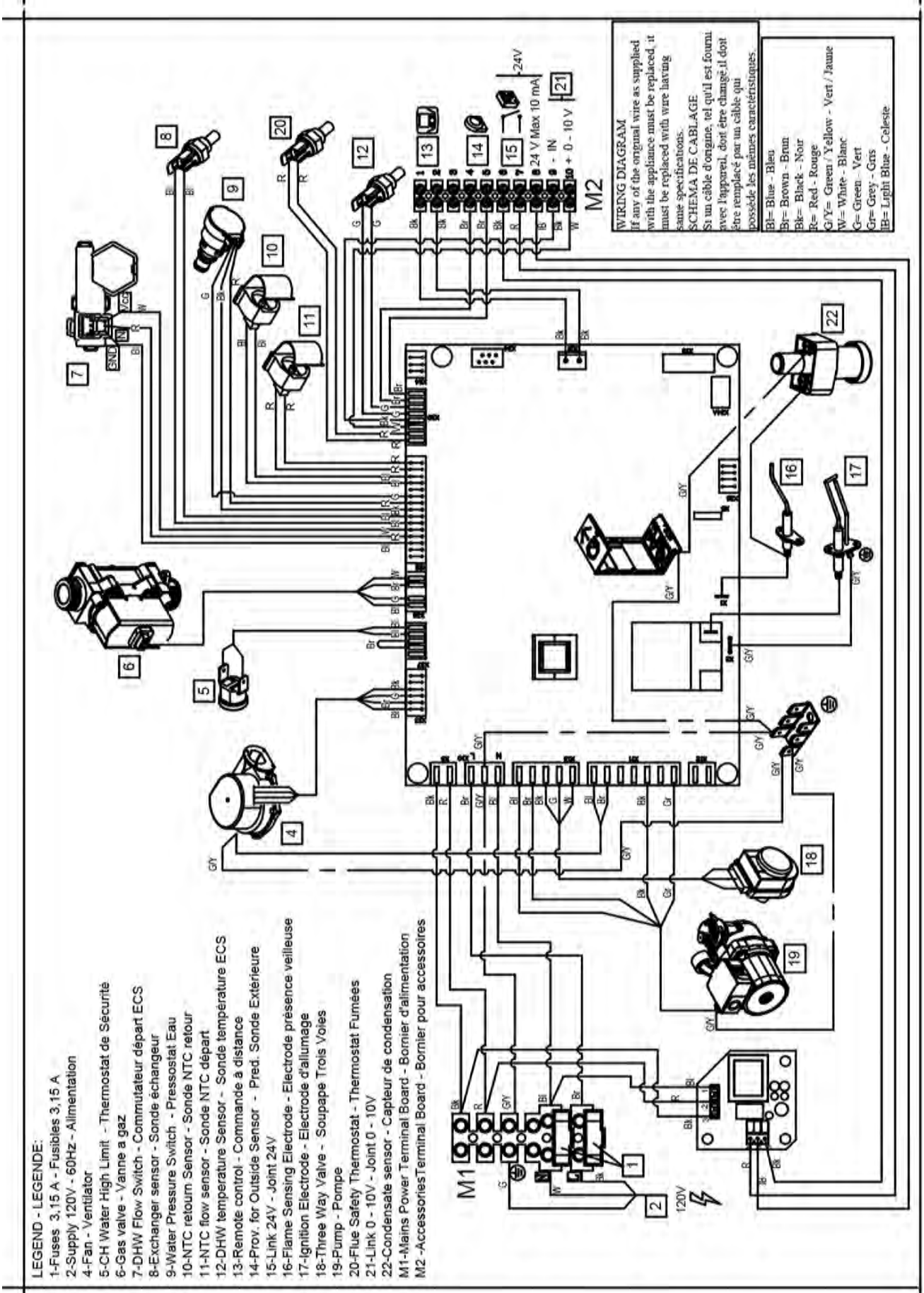




A-3 MODEL 165 - Heat Only



A-4 MODEL 115 - Combi



LEGEND - LEGENDE:

- 1-Fuses 3,15 A - Fusibles 3,15 A
- 2-Supply 120V - 60Hz - Alimentation
- 4-Fan - Ventilator
- 5-CH Water High Limit - Thermostat de Sécurité
- 6-Gas valve - Vanne a gaz
- 7-DHW Flow Switch - Commutateur départ ECS
- 8-Exchanger sensor - Sonde échangeur
- 9-Water Pressure Switch - Pressostat Eau
- 10-NTC return sensor - Sonde NTC retour
- 11-NTC flow sensor - Sonde NTC départ
- 12-DHW temperature sensor - Sonde température ECS
- 13-Remote control - Commande à distance
- 14-Prev. for Outside Sensor - Pred. Sonde Extérieure
- 15-Link 24V - Joint 24V
- 16-Flame Sensing Electrode - Electrode présence veilleuse
- 17-Ignition Electrode - Electrode d'allumage
- 18-Three Way Valve - Soupape Trois Voies
- 19-Pump - Pompe
- 20-Flue Safety Thermostat - Thermostat Fumées
- 21-Link 0 - 10V - Joint 0 - 10V
- 22-Condensate sensor - Capteur de condensation
- M1-Mains Power Terminal Board - Bornier d'alimentation
- M2-Accessories Terminal Board - Bornier pour accessoires

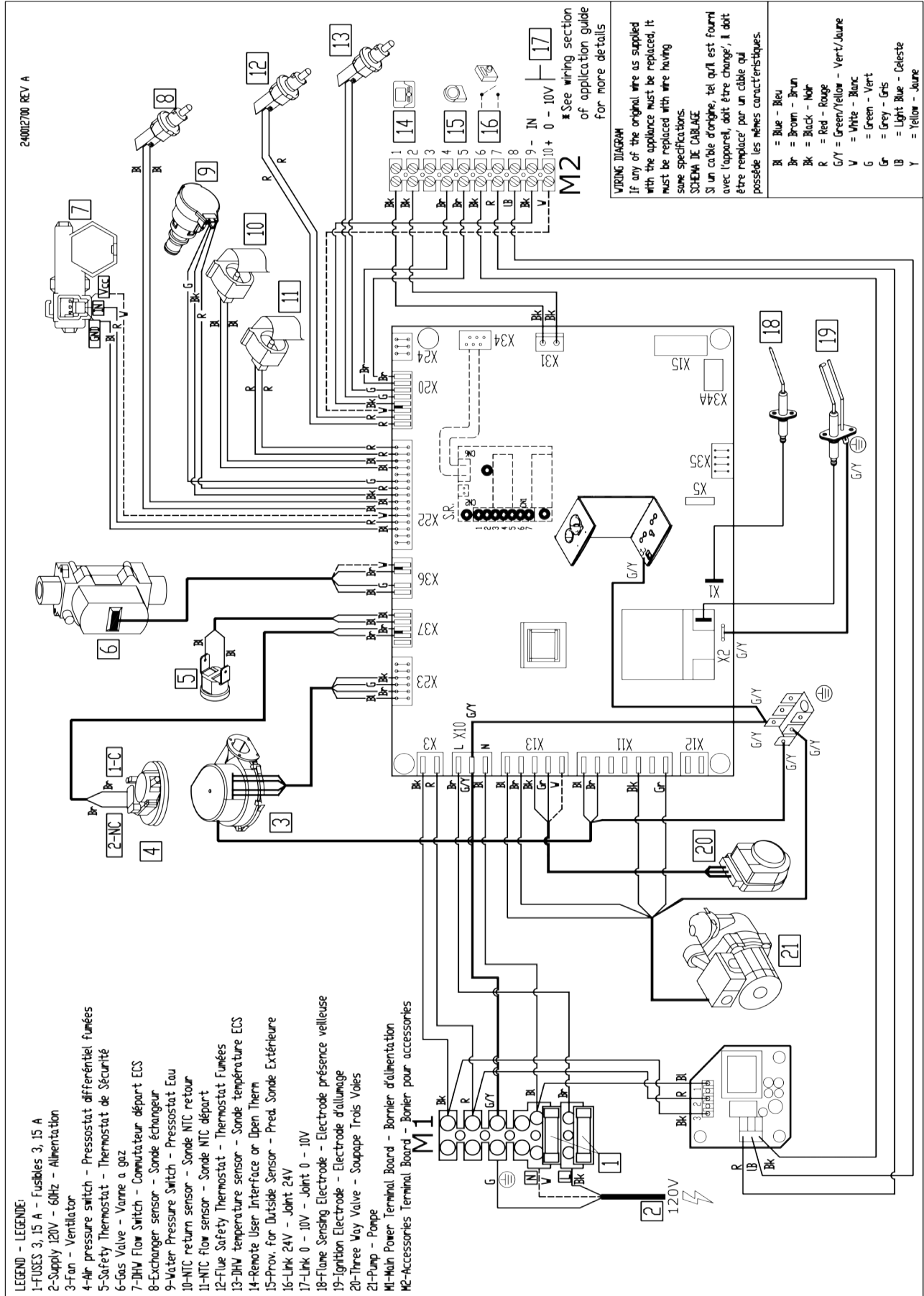
**WIRING DIAGRAM**  
 If any of the original wire as supplied with the appliance must be replaced, it must be replaced with wire having same specifications.

**SCHEMA DE CABLAGE**  
 Si un câble d'origine, tel qu'il est fourni avec l'appareil, doit être changé, il doit être remplacé par un câble qui possède les mêmes caractéristiques.

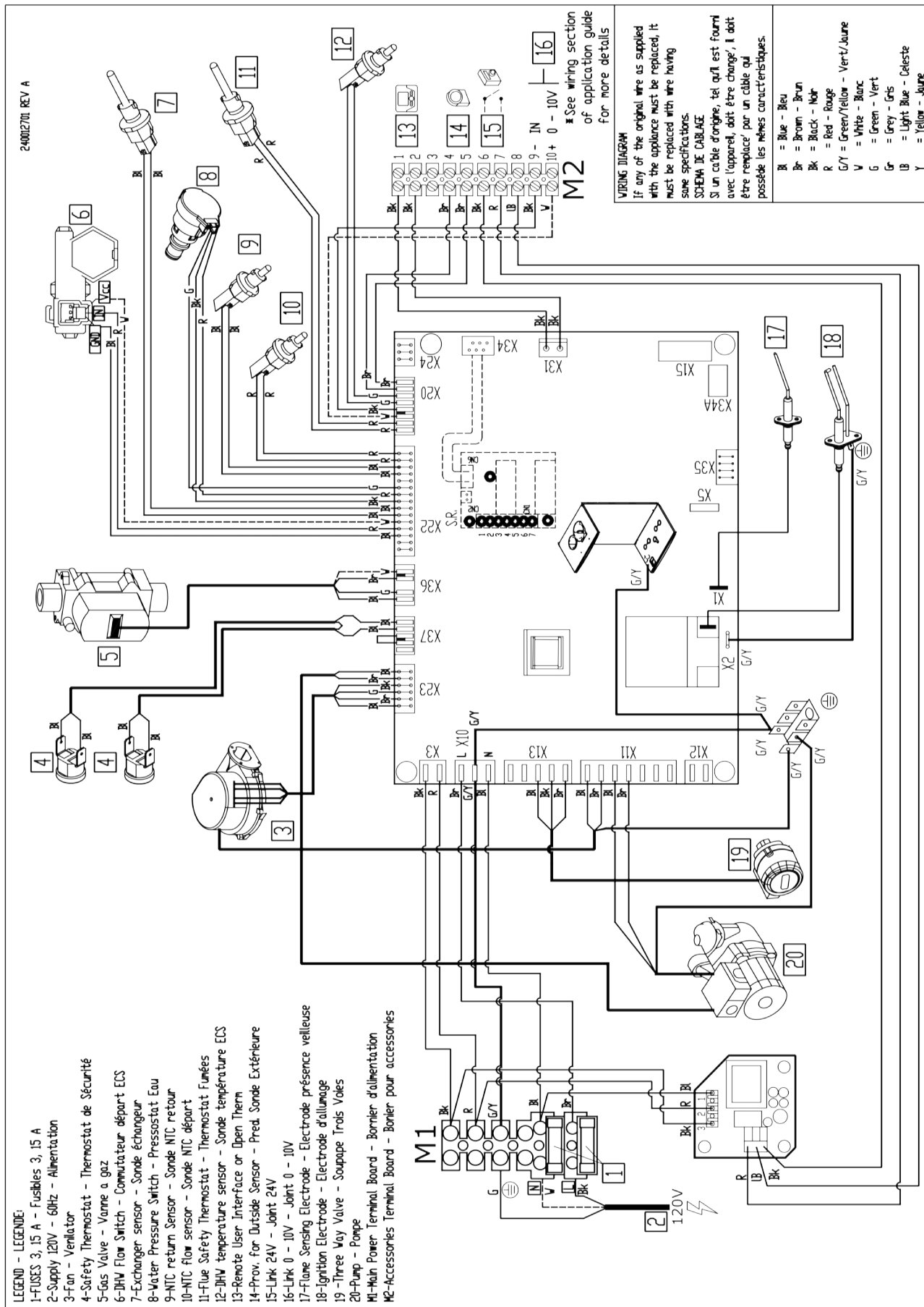
Bl= Blue - Bleu  
 Br= Brown - Brun  
 Bk= Black - Noir  
 R= Red - Rouge  
 G/Y= Green / Yellow - Vert / Jaune  
 G= Green - Vert  
 W= White - Blanc  
 Gr= Grey - Gris  
 Blu= Light Blue - Celeste

# APPENDIX A - WIRING DIAGRAMS

## A-5 MODEL 150 - Combi



A-6 MODEL 205 - Combi



**INSTALLATION AND CHECK-OUT CERTIFICATE**

**Boiler Model** \_\_\_\_\_ **Serial #** \_\_\_\_\_ **Date Installed** \_\_\_\_\_

**Measured BTU/HR input** \_\_\_\_\_

- Installation instructions have been followed**
- Checkout procedure and adjustments performed**
- Maintenance and Service issues reviewed with owner/ maintenance person**
- Installation booklet affixed on or adjacent to boiler**

**Installer (Company)** \_\_\_\_\_

**Address** \_\_\_\_\_

**Phone** \_\_\_\_\_

**Installer's Name** \_\_\_\_\_

**Signature** \_\_\_\_\_



## IMPORTANT

In accordance with Section 325 (f) (3) of the Energy Policy and Conservation Act, this boiler is equipped with a feature that saves energy by reducing the boiler water temperature as the heating load decreases.

This feature is equipped with an override which is provided primarily to permit the use of an external energy management system that serves the same function.

**THIS OVERRIDE MUST NOT BE USED UNLESS AT LEAST ONE OF THE FOLLOWING CONDITIONS IS TRUE:**

- An external energy management system is installed that reduces the boiler water temperature as the heating load decreases.
- This boiler is not used for any space heating
- This boiler is part of a modular or multiple boiler system having a total input of 300,000 BTU/hr or greater.
- This boiler is equipped with a tankless coil.



**APPLICATION GUIDE  
FOR USE WITH  
FLOOR STANDING  
HEATING ONLY - 75F, 100F, 125F, 165F  
&  
COMBI - 115F, 150F, 205F**

This manual has been prepared for use with the appropriate Installation, Operation and Maintenance Manual.



**Manufactured by:**  
ECR International Inc.  
2201 Dwyer Avenue, Utica, NY 13501  
Tel. 800 325 5479  
[www.ecrinternational.com](http://www.ecrinternational.com)  
PN 240012875 REV. D [03/15/2022]

## TABLE OF CONTENTS

<b>Important Safety Information</b> .....	<b>3</b>
<b>Labor Saving Piping Manifolds / Near Boiler Piping Connections</b> .....	<b>4</b>
<b>General Information - Hydronic Piping</b> .....	<b>6</b>
<b>General Information - wiring</b> .....	<b>8</b>
<b>Piping and Wiring Diagrams</b>	
<b>Piping Legend</b> .....	<b>9</b>
75F, 100F, 125F w/Zone circulators & DHW Tank- piping diagram .....	10
75F, 100F, 125F W/Indirect Zone circulators, DHW tank w/Sensor - Wiring Dia. ....	11
75F, 100F, 125F w/Indirect Zone circulators & DHW Tank w/t-stat - WIRING Dia.....	12
75F, 100F, 125F with Zone Valves & DHW Tank - PIPING Diagram .....	13
75F, 100F, 125F with Zone Valves, DHW Tank W/Sensor - Wiring Dia. ....	14
75F, 100F, 125F zone valves, DHW tank w/t-stat - wiring Diagram.....	15
165F with Zone Circulators - PIPING Diagram .....	16
165F indirect Zone Circulators, DHW Tank w/ T-Stat - Wiring Dia. ....	17
165F with zone Valves - PIPING Diagram .....	18
165F with Indirect Zone Valves, DHW Tank, Tank T-Stat - Wiring Dia. ....	19
115F, 150F & 205F with zone circulators - PIPING Diagram .....	20
115F, 150F & 205F with zone Circulators - Wiring Diagram .....	21
115F, 150F & 205F with Zone Valves - PIPING Diagram .....	22
115F, 150F & 205F with Zone Valves - Wiring Diagram .....	23
EXTERNAL buffer TANK - PIPING Diagram .....	24
EXTERNAL buffer TANK - Wiring Diagram .....	26
<b>Optional Equipment</b> .....	<b>29</b>
CHART 1 -1k $\Omega$ OUTDOOR AIR SENSOR DATA .....	29
CHART 2 -10k $\Omega$ INDIRECT TANK SENSOR DATA .....	29
<b>Accessories</b> .....	<b>30</b>
Outdoor Temperature Sensor Kit .....	30
Indirect Storage Tank Sensor .....	31
<b>Wiring Diagrams</b>	
Single Zone Circulator Wiring Using ARGO AR822-II .....	32
75 & 100 - Heat Only Wiring Diagram .....	33
125 - Heat Only Wiring Diagram .....	34
165 - Heat Only Wiring Diagram .....	35
115 - combi Wiring Diagram.....	36
150 - combi Wiring Diagram.....	37
205 - combi Wiring Diagram.....	38
<b>Altitude Effects On Boiler Performance</b> .....	<b>39</b>
<b>Application Table - Indirect Hot Water Tank Sizing</b> .....	<b>41</b>
<b>LWCO Wiring Diagram</b> .....	<b>42</b>
<b>Piping Diagram - LWCO Location</b> .....	<b>43</b>
<b>Low Water Cutoff - Detail</b> .....	<b>44</b>
<b>Error Code Table</b> .....	<b>45</b>
<b>Troubleshooting Chart</b> .....	<b>46</b>
<b>Fault Solution Sections</b> .....	<b>48</b>
<b>PARAMETER CHANGE HISTORY</b> .....	<b>52</b>

## IMPORTANT SAFETY INFORMATION

### 1. Become familiar with symbols identifying potential hazards.



This is the safety alert symbol. Symbol alerts you to potential personal injury hazards. Obey all safety messages following this symbol to avoid possible injury or death.

#### **DANGER**

Indicates a hazardous situation which, if not avoided, WILL result in death or serious injury.

#### **WARNING**

Indicates a hazardous situation which, if not avoided, could result in death or serious injury.

#### **CAUTION**

Indicates a hazardous situation which, if not avoided, could result in minor or moderate injury.

### 2. General

Boiler installation shall be completed by qualified agency. See Installation, Operation & Maintenance Manual for additional information.

#### **WARNING**

Fire, explosion, asphyxiation and electrical shock hazard. Improper installation could result in death or serious injury. Read this manual and understand all requirements before beginning installation.

#### **WARNING**

Fire, Explosion, Asphyxiation, Electrical shock hazard! Flooding will result in damages such as electrical problems, corrosion, inoperative parts, mold and other unforeseen issues which can occur over time. Any equipment determined by a professional as damaged by a flood, defined as excess of water or other liquid, shall be replaced. Failure to follow these directions will result in a Hazardous Situation.

### 3. Installation shall conform to requirements of authority having jurisdiction or in absence of such requirements:

- *United States*
  - National Fuel Gas Code, ANSI Z223.1/NFPA 54.
  - National Electrical Code, NFPA 70.
- *Canada*
  - Natural Gas and Propane Installation Code, CAN/CSA B149.1.
  - Canadian Electrical Code, Part I, Safety Standard for Electrical Installations, CSA C22.1

### 4. Where required by authority having jurisdiction, installation shall conform to Standard for Controls and Safety Devices for Automatically Fired Boilers, ANSI/ASME CSD-1.

Additional manual reset low water cutoff and/or high limit may be required.

### 5. Requirements for Commonwealth of Massachusetts:

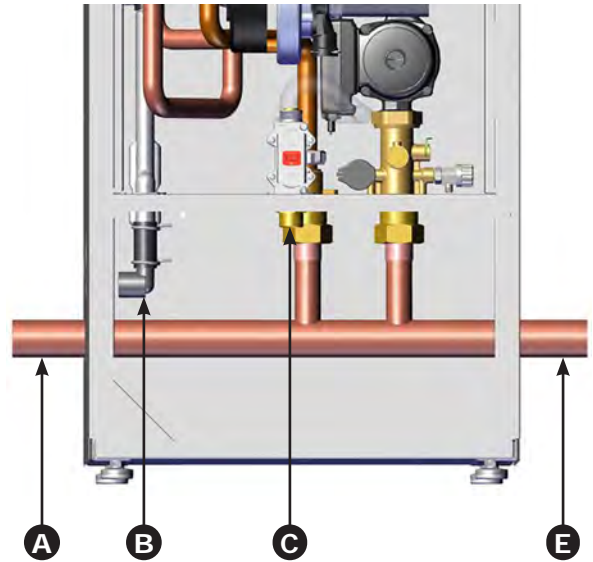
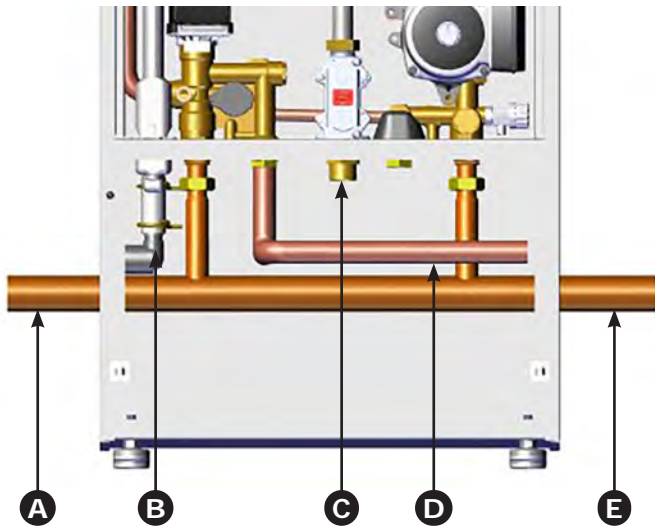
Boiler installation must conform to Commonwealth of Massachusetts code 248 CMR which includes but is not limited to:

- Installation by licensed plumber or gas fitter.

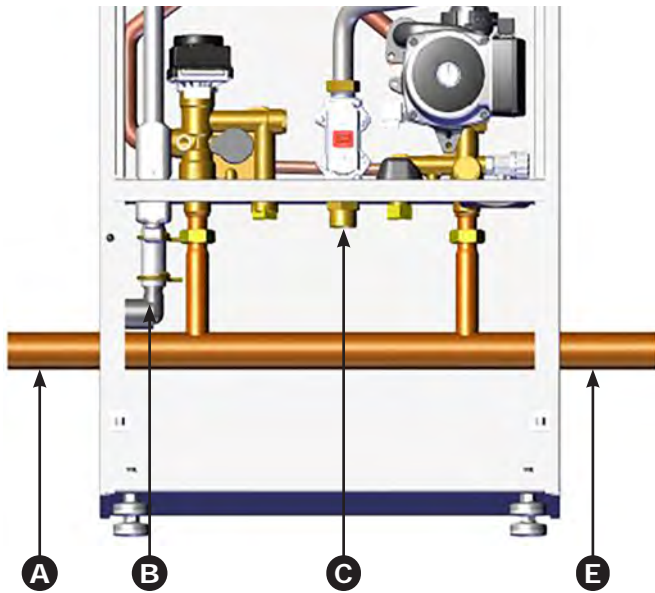
# LABOR SAVING PIPING MANIFOLDS / NEAR BOILER PIPING CONNECTIONS

**75F, 100F & 125F HEATING ONLY**  
**WITH OPTIONAL INDIRECT DHW CONNECTION**

**165F HEATING ONLY**



**75F, 100F & 125F HEATING ONLY**  
**WITHOUT OPTIONAL INDIRECT DHW CONNECTION**

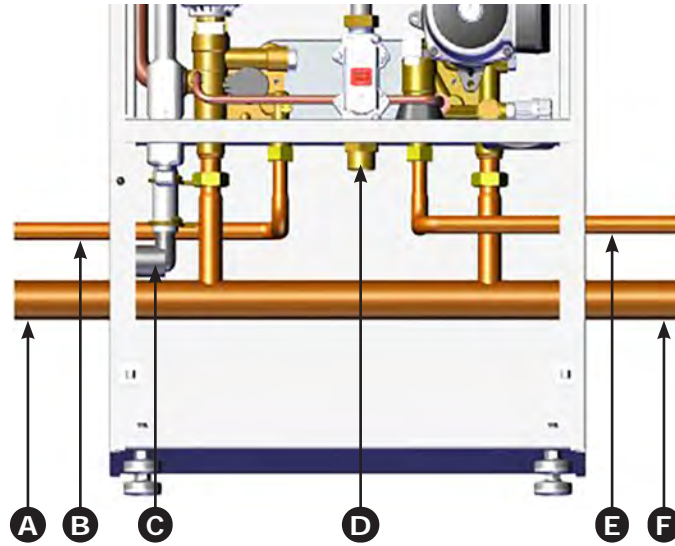


LEGEND		75/100/125	165
A	Heating Supply Connection	1¼" sweat [31.75 mm]	1½" sweat [38.1 mm]
B	Condensate Drain Connection	½" NPT	
C	Gas Shutoff Connection	¾" NPT	
D	Optional Indirect DHW Connection (may exit right or left)	¾" sweat [22.2 mm]	NA
E	Heating Return Connection	1¼" sweat [31.8 mm]	1½" sweat [38.1 mm]



# LABOR SAVING PIPING MANIFOLDS / NEAR BOILER PIPING CONNECTIONS

## 115F & 150F/205F COMBI (150 shown)



LEGEND		115/150	205
A	Heating Supply Connection	1¼" sweat [31.75 mm]	1½" sweat [38.1 mm]
B	Domestic Hot Water Outlet	1/2" sweat [12.7 mm]	3/4" sweat [22.2 mm]
C	Condensate Drain Connection	1/2" NPT	
D	Gas Shutoff Connection	3/4" NPT	
E	Domestic Cold Water Inlet	1/2" sweat [12.7 mm]	3/4" sweat [22.2 mm]
F	Heating Return Connection	1¼" sweat [31.8 mm]	1½" sweat [38.1 mm]

### ⚠ WARNING

Burn and scald hazard! Manufacturer requires installation of field supplied anti-scald valve. Failure to follow these instructions could result in death or serious injury.

#### General Information:

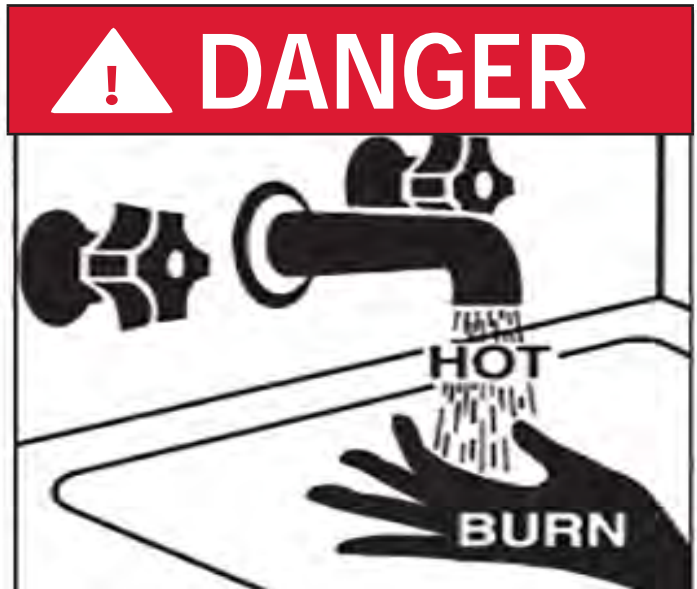
Piping installation, materials, and joining methods shall conform to requirements of authority having jurisdiction or in absence of such requirements:

- **USA** - National Fuel Gas Code, ANSI Z223.1/NFPA 54
- **Canada** - Natural Gas and Propane Installation Code, CAN/CSA B149.1

#### Manufacturer Requirements/Recommendations:

- **Manufacturer requires all domestic hot water (DHW) installations use an anti-scald valve.** Local codes may require additional equipment (expansion tank, relief valves, etc.) Select and size equipment to suit installation and meet code requirements.
- Use a water filter on potable incoming water supply line.
- Manufacturer recommends use of a magnetic dirt separator in the hydronic system where there are cast iron or steel components, or where the previous boiler was a cast iron heat exchanger. The abrasive, extremely fine sediment is difficult to remove and can deposit onto heat exchanger surfaces and accumulate in pump cavities causing reduced efficiency and premature wear.
- If the piping manifold is not used the ASME temperature and pressure relief valve and temperature and pressure gauge shall be installed to conform to requirements of the authority having jurisdiction. Refer to appropriate manufacturer instructions for installation requirements.
- If the piping manifold is not used, a primary / secondary piping arrangement is manufacturer required, unless using Buffer Tank. A maximum of 12 in of separation between the supply and return pipe (closely spaced tees) of the boiler shall be maintained. Limit combined supply and return pipe lengths to maximum linear lengths of 20 ft (6.1 m) between boiler and closely spaced tees, when minimum ¾ in NPT pipe size is used. Linear length may be increased if supply and return pipe size is increased to limit pressure drop.
- Manufacturer recommends installing a shutoff and purge valve to use during commissioning to ensure the boiler does not shut down due to over temperature. Do not install shutoff between boiler and LWCO or pressure relief valve.

**FOR YOUR SAFETY READ BEFORE OPERATING**



#### Hot Water Can Scald!

Water heated to temperature for clothes washing, dish washing and other sanitizing needs can scald and cause permanent injury.

Children, elderly, and infirmed or physically handicapped persons are more likely to be permanently injured by hot water. Never leave them unattended in bathtub or shower. Never allow small children to use a hot water tap or draw their own bath.

If anyone using hot water in the building fits the above description, or if state laws or local codes require certain water temperatures at hot water taps, you must take special precautions:

- Use lowest possible temperature setting.
- Install some type of tempering device, such as an automatic mixing valve, at hot water tap or water heater. Automatic mixing valve must be selected and installed according to manufacturer's recommendations and instructions.
- Water passing out of drain valves may be extremely hot. To avoid injury:
  - ◇ Make sure all connections are tight.
  - ◇ Direct water flow away from any person.

## GENERAL INFORMATION - HYDRONIC PIPING

Water Temperature Setting	1st Degree Burn Exposure Time For An Adult	2nd and 3rd Degree Burn Exposure Time For An Adult
120° F	1 minute	5 minutes
130° F	5 seconds	30 seconds
140° F	2 seconds	5 seconds
150° F	1 second	1.5 seconds
160° F	Instantaneous	0.5 seconds

**Note:** Warning for Infants, Children, and Elderly: Great care must be taken when exposing the aforementioned groups to warm or hot water as they can be badly burned in exposure times less than half of the time for an adult.

**Note** → Provided Wiring and Piping illustrations are meant to show system concepts only. Installer is responsible for all equipment required by authority having jurisdiction.

**Note** → Arrange piping to prevent water dripping onto boiler.

All piping diagrams are shown with optional DHW Indirect Tank where applicable.

The Labor Saver Piping Manifold, which is supplied with each boiler, is shown with most of the following piping diagrams.

### Use of Indirect Water Heater (DHW) Heating Only Boiler:

**Note** → Sensors supplied with this boiler are proprietary to the manufacturer. Use of alternate sensors *WILL* diminish boiler performance.

- Use DHW sensor kit 550003189 to interface with boiler. Wire to M2 terminals #3 and #4. Exception: not applicable for the 165 model, use aquastat for indirect tank control.
- For heating only boilers with DHW outlet connection, see page 4, indirect water heater shall be piped utilizing the internal boiler pump. See pages 10 and 13.
- Locate tank as close to boiler as possible.
- See Indirect Tank Performance chart, page 40 of this manual.
- Change P03 on boiler for application as specified on the applicable wire diagram in this manual or Boiler Control Section 9 of Installation, Operation & Maintenance Manual supplied with the boiler.

### Use of Buffer Tank:

- If using internal boiler pump, manifold shall be cut for use as shown on page 24. Increase pipe size to match Buffer tank connections as shown.
- Locate tank as close to boiler as possible.

## GENERAL INFORMATION - WIRING

### Electrical Wiring Information:

All field wiring shall conform to the authority having jurisdiction or, in the absence of such requirements to:

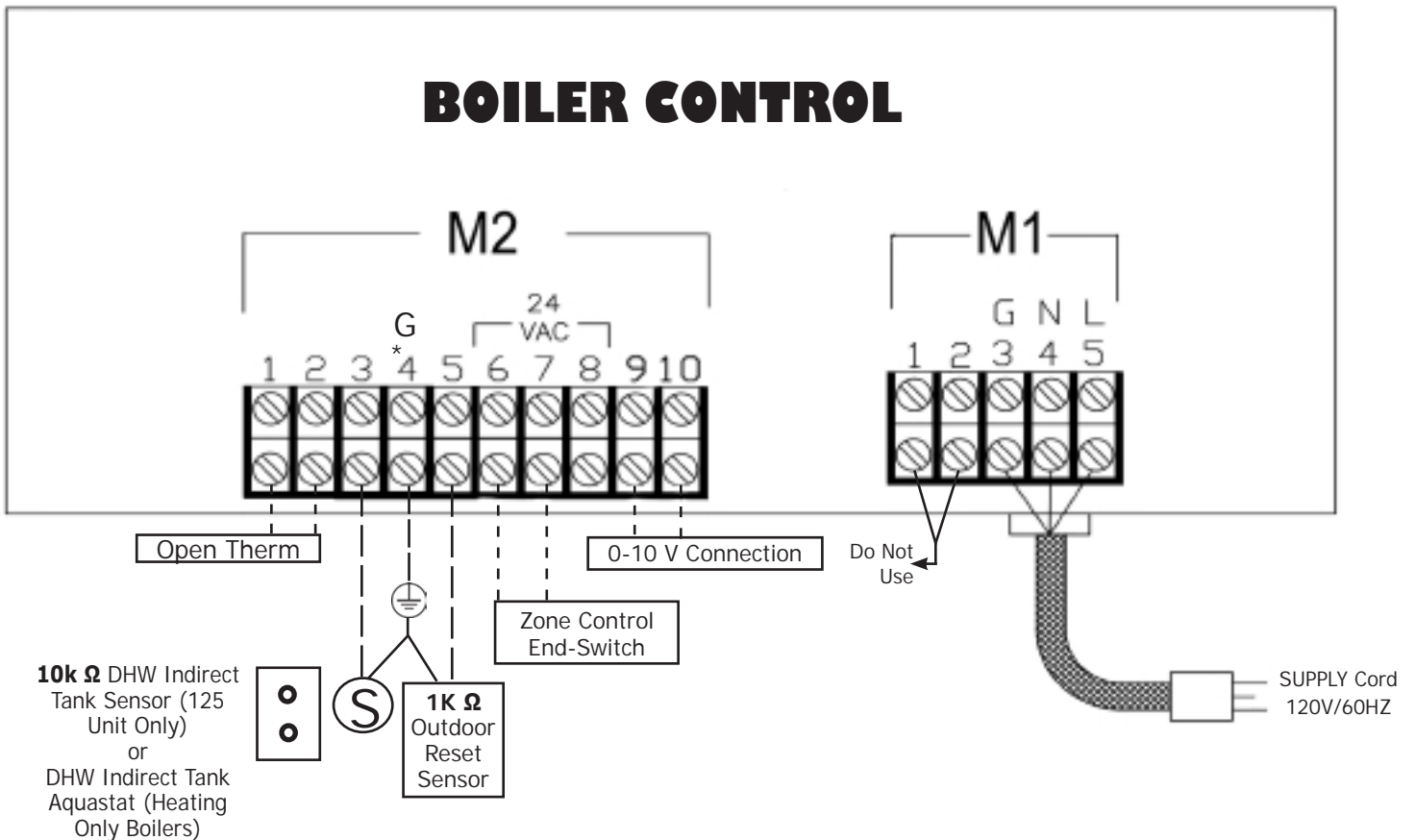
- **USA:** National Electrical Code, ANSI/NFPA 70,
- **Canada:** Canadian Electrical Code, Part I, CSA C22.1: Safety Standard for Electrical Installations.

Wiring diagrams shown in this manual utilize ARGO™ Controls, the **optional** use of an Indirect Domestic Hot Water Tank, and **optional** use of a H2O Buffer Tank.

Reference the zone control manufacturer instruction manual for control operation and priority setting of DHW zones.

**Note** → **DO NOT** use 120 V thermostat terminals (M1- #1 and #2).

**Note** → **Provided Wiring and Piping illustrations are meant to show system concepts only. Installer is responsible for all equipment required by authority having jurisdiction.**



\* Ground Sensors using terminal 4

# PIPING LEGEND

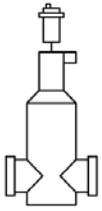
## PIPING LEGEND



ZONE VALVE



BALL VALVE



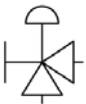
AIR SEPERATOR



CIRCULATOR



DRAIN



COMBINATION FILL



FLOW CHECK VALVE



BYPASS VALVE



DIVERTER VALVE



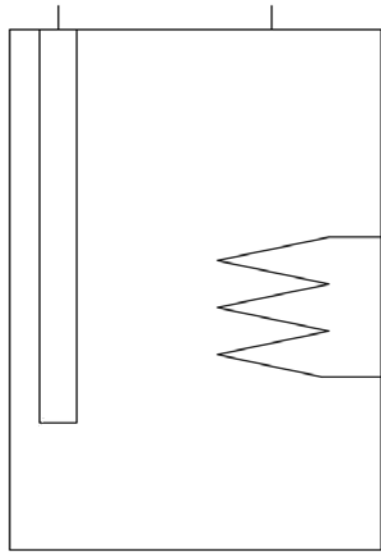
T&P OR RELIEF VALVE



THERMOSTATIC MIXING VALVE



PURGE VALVE



DHW INDIRECT TANK



INDIRECT TANK AQUASTAT



10K  $\Omega$  INDIRECT DHW TANK SENSOR



TEMPERATURE & PRESSURE GAUGE



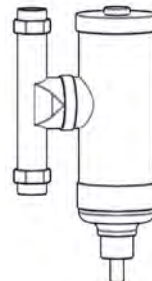
EXPANSION TANK



FLAT PLATE HEAT EXCHANGER  
(COMBI ONLY)



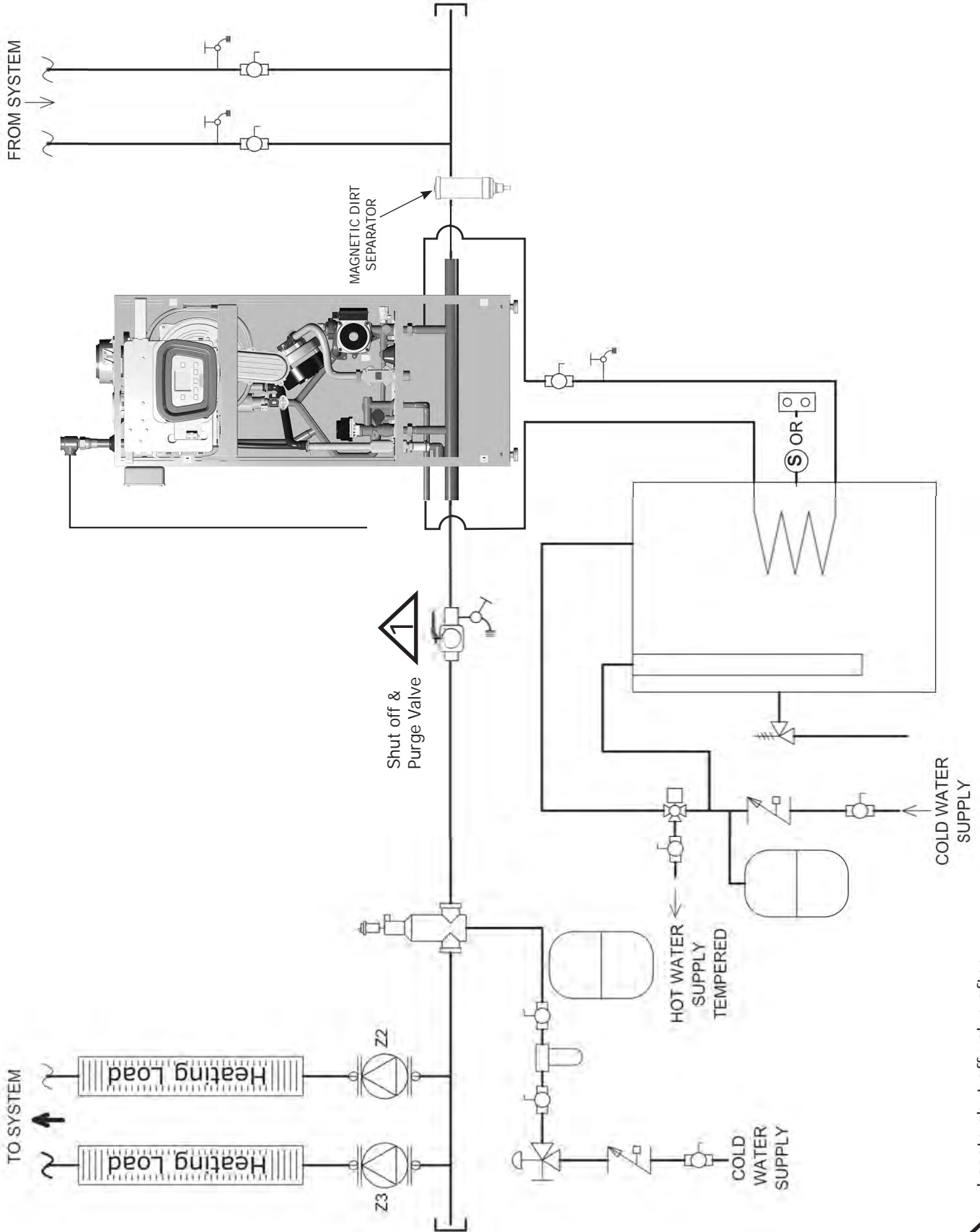
STRAINER



MAGNETIC DIRT SEPARATOR

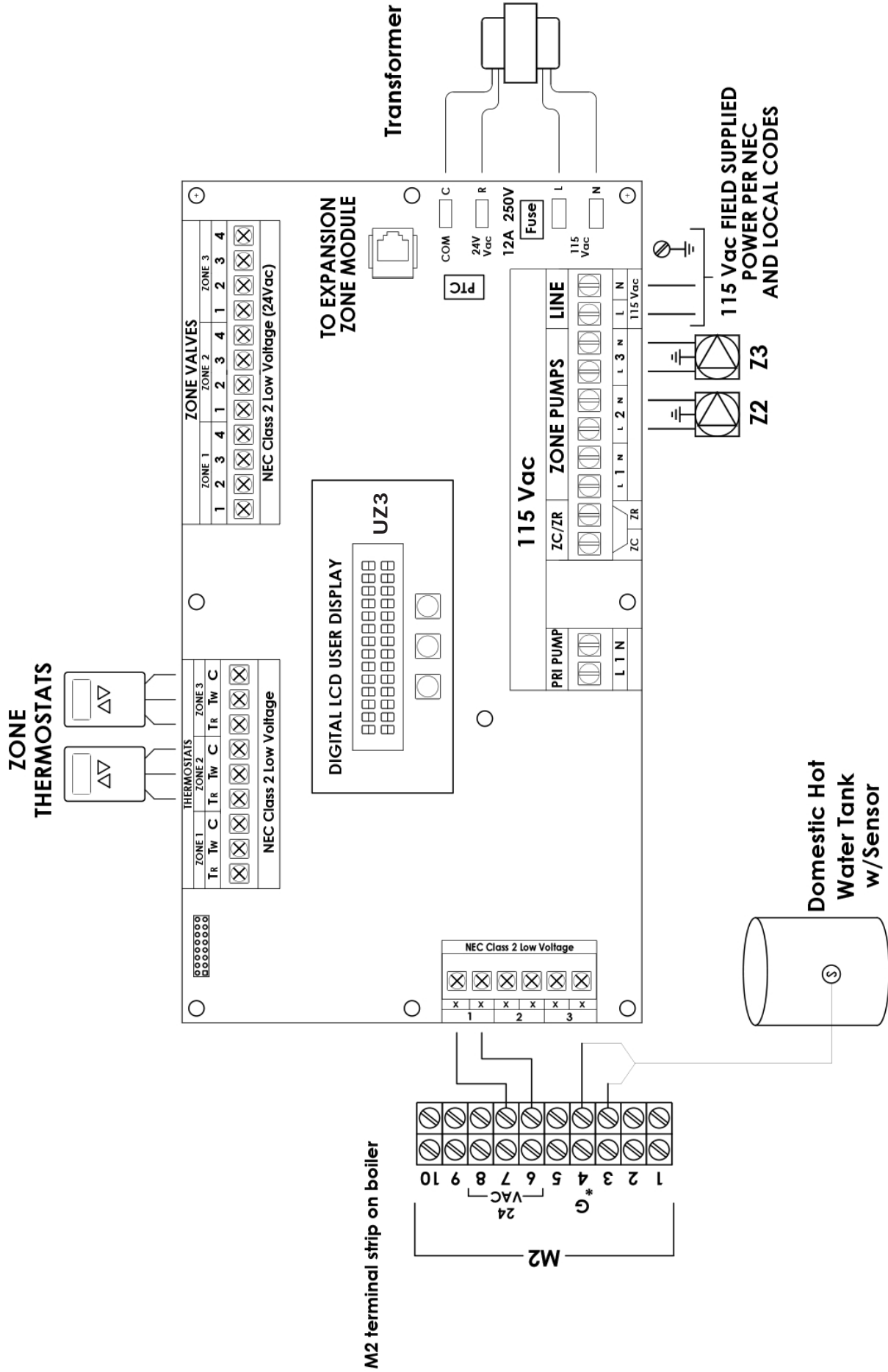


75F, 100F & 125F W/ ZONE CIRCULATORS & DHW TANK- PIPING DIAGRAM



Locate shut off valve after any field installed LWCO.

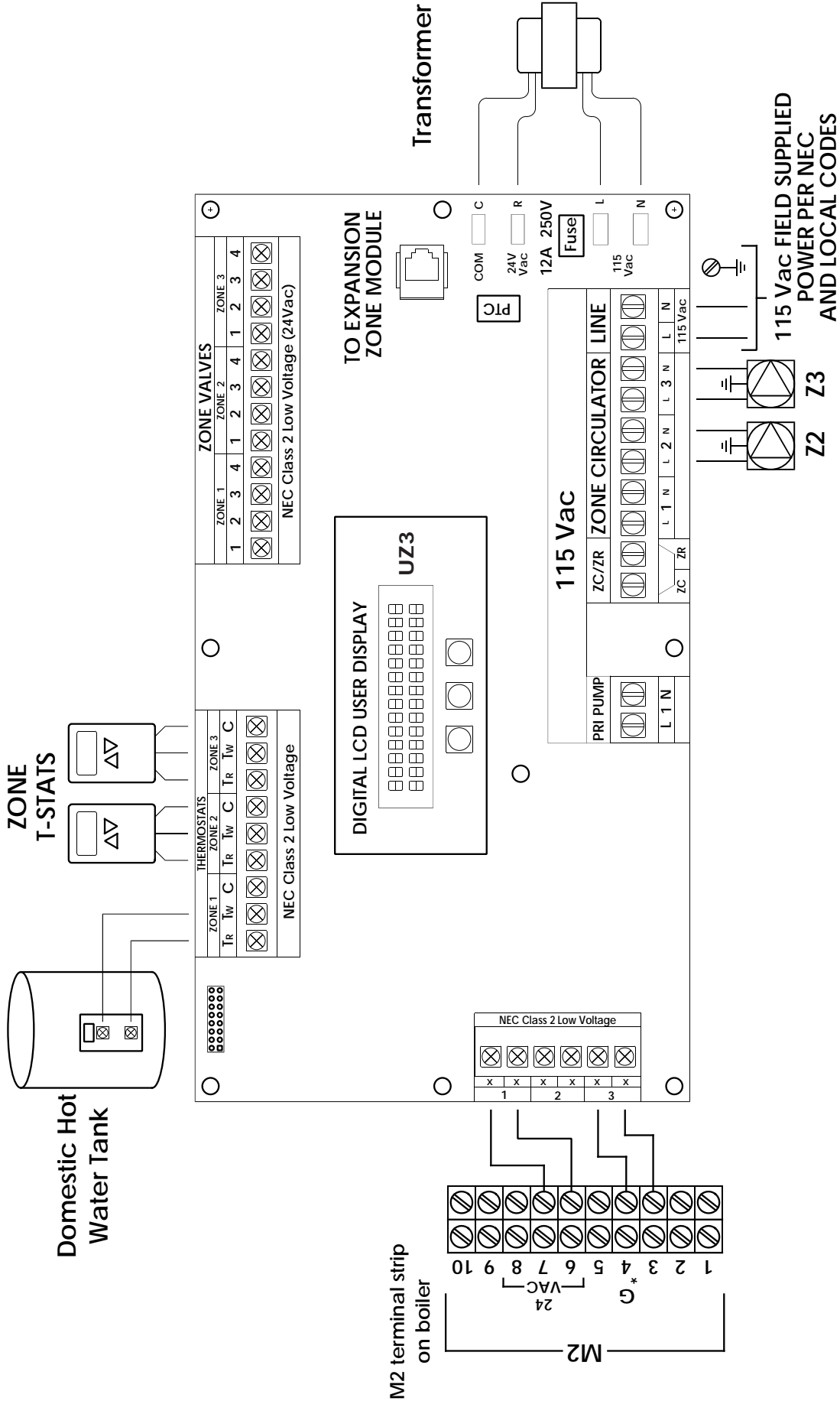
75F, 100F & 125F WITH INDIRECT ZONE CIRCULATORS & DHW TANK W/SENSOR, ARGO UZ3 ZONE CONTROL



If adding an indirect tank with **sensor** to a **Heating Only Boiler**, change P03 from 08 to 05. See Section 9, Parameter Settings in Boiler Installation, Operation & Maintenance Manual for details.

Reference zone control manufacturer instructions for details on setting priority if necessary.

75F, 100F & 125F W/ INDIRECT ZONE CIRCULATORS & DHW TANK W/T-STAT, ARGO UZ3 ZONE CONTROL WIRING DIAGRAM

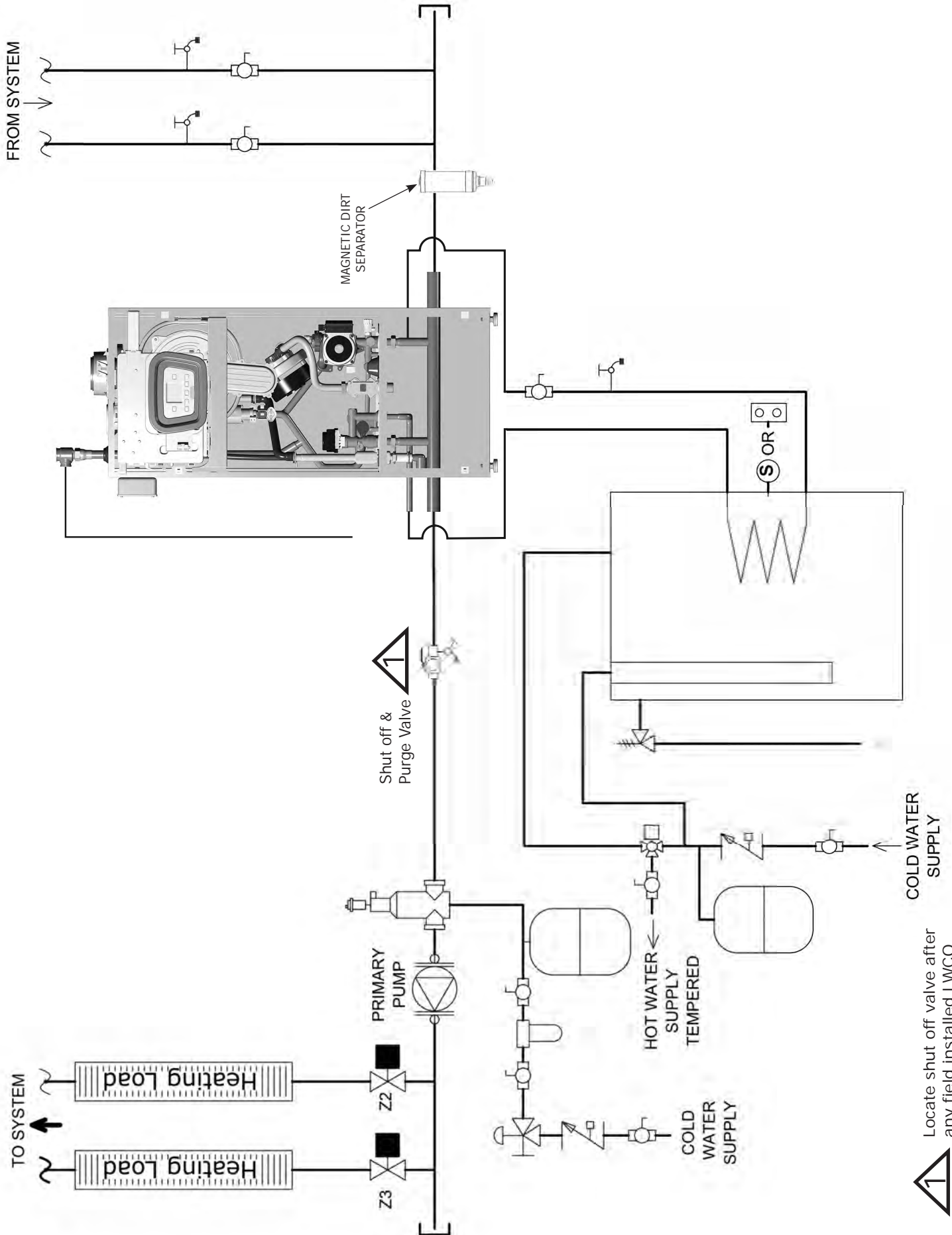


If adding an indirect tank with **Thermostat** to a **Heating Only Boiler**, change P03 from 08 to 04. See Section 9, Parameter Settings in Boiler Installation, Operation & Maintenance Manual for details.

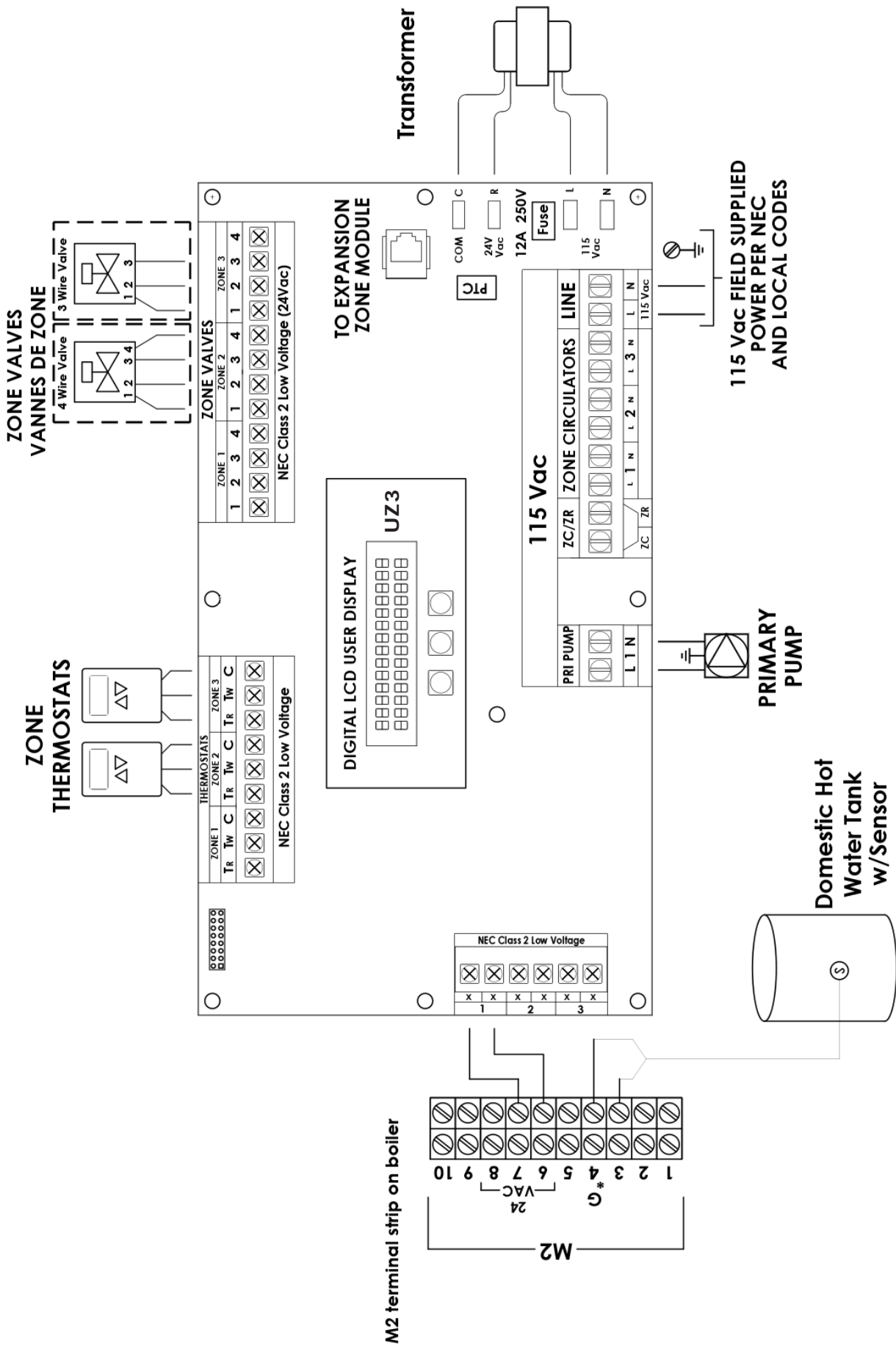
Reference zone control manufacturer instructions for details on setting priority if necessary.

75F, 100F, 125F WITH ZONE VALVES & DHW TANK - PIPING DIAGRAM

75F, 100F & 125F WITH ZONE VALVES & DHW TANK



75F, 100F & 125F WITH ZONE VALVES, DHW TANK W/ SENSOR, ARGO UZ3 ZONE CONTROL

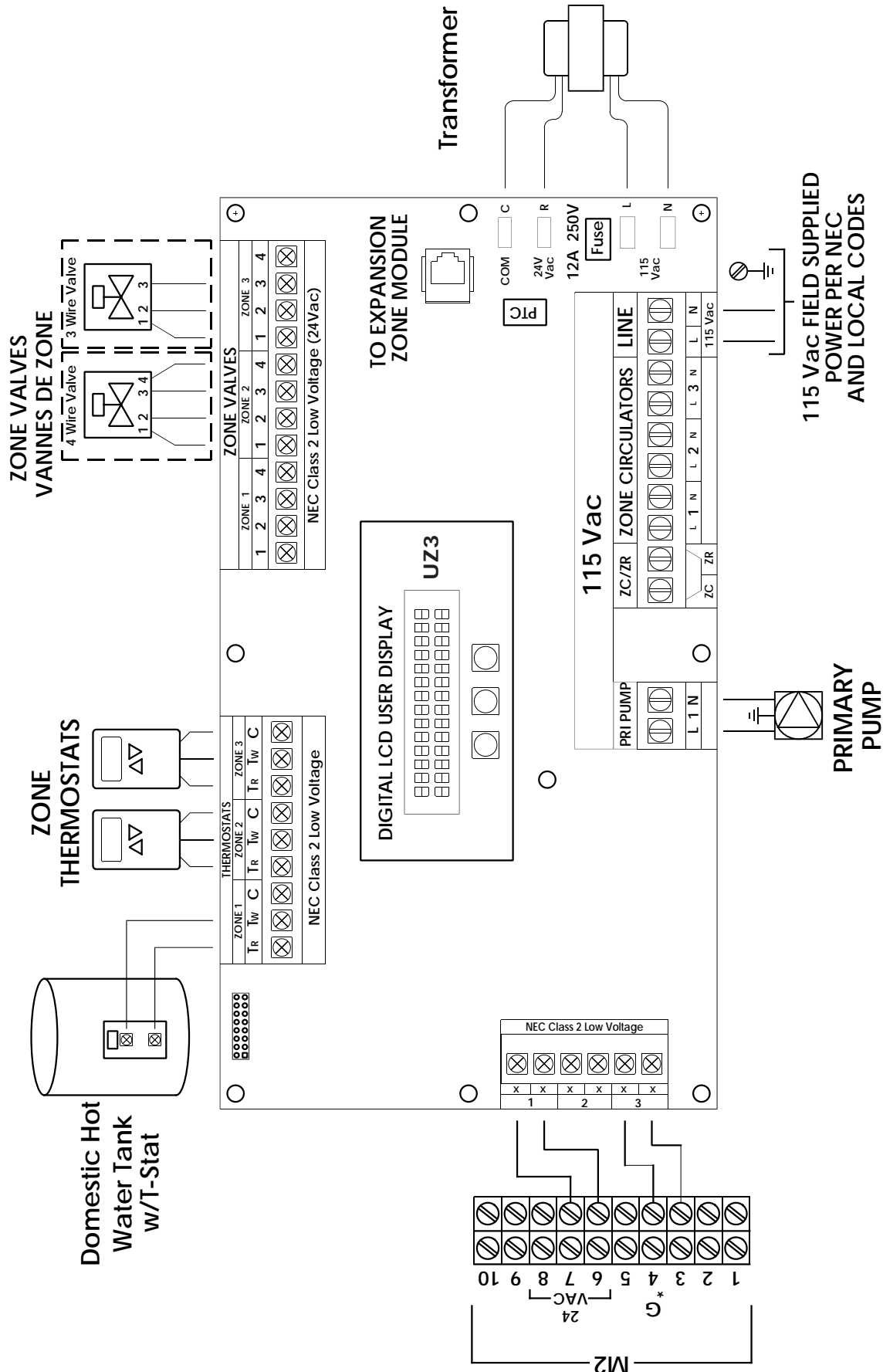


If adding an indirect tank with **sensor** to a **Heating Only Boiler**, change P03 from 08 to 05. See Section 9, Parameter Settings in Boiler Installation, Operation & Maintenance Manual for details.

Reference zone control manufacturer instructions for details on setting priority if necessary.



75F, 100F & 125F WITH ZONE VALVES, DHW TANK , & TANK T-STAT, ARGO UZ3 ZONE CONTROL

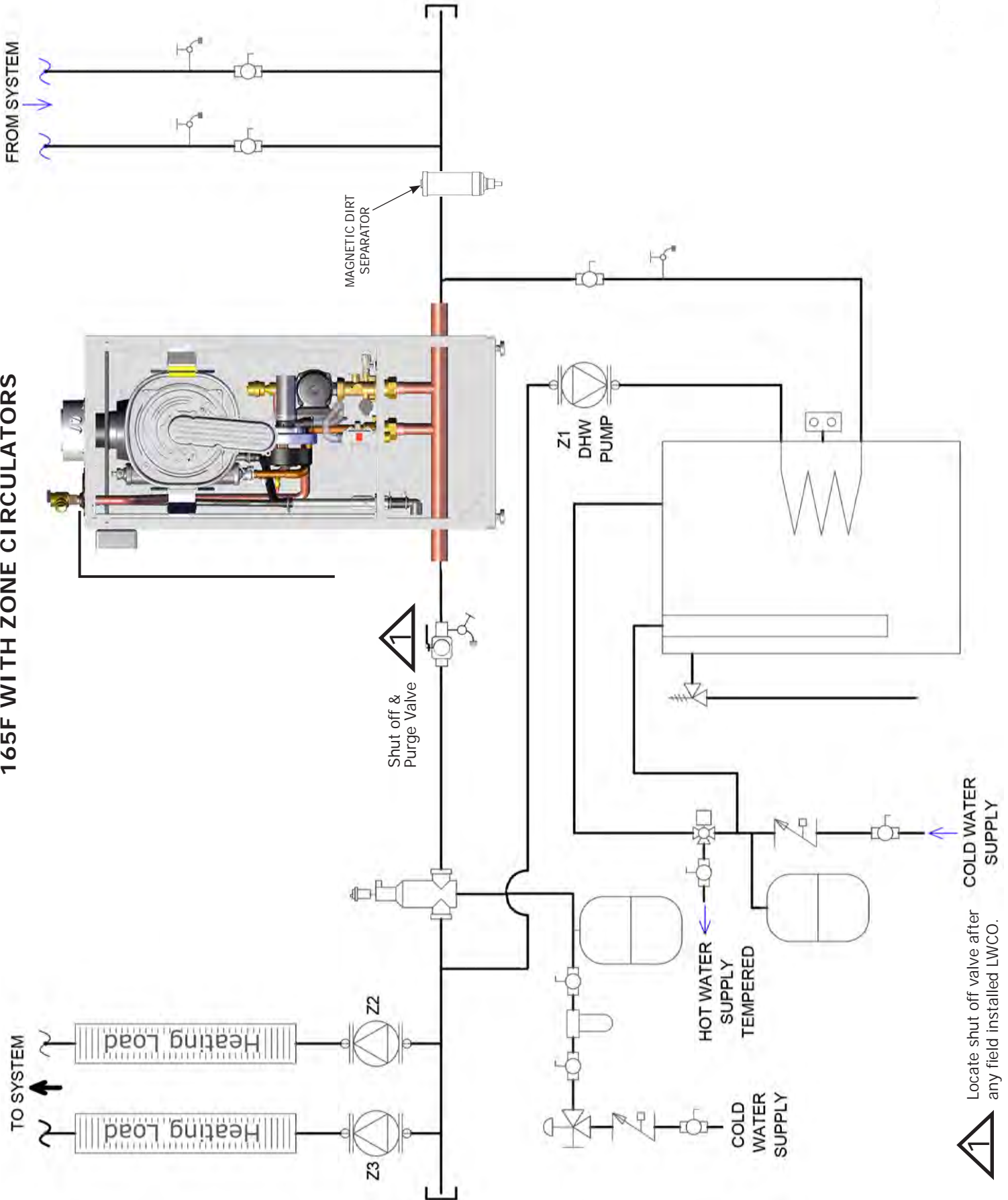


If adding an indirect tank with **Thermostat** to a **Heating Only Boiler**, change P03 from 08 to 04. See Section 9, Parameter Settings in Boiler Installation, Operation & Maintenance Manual for details.

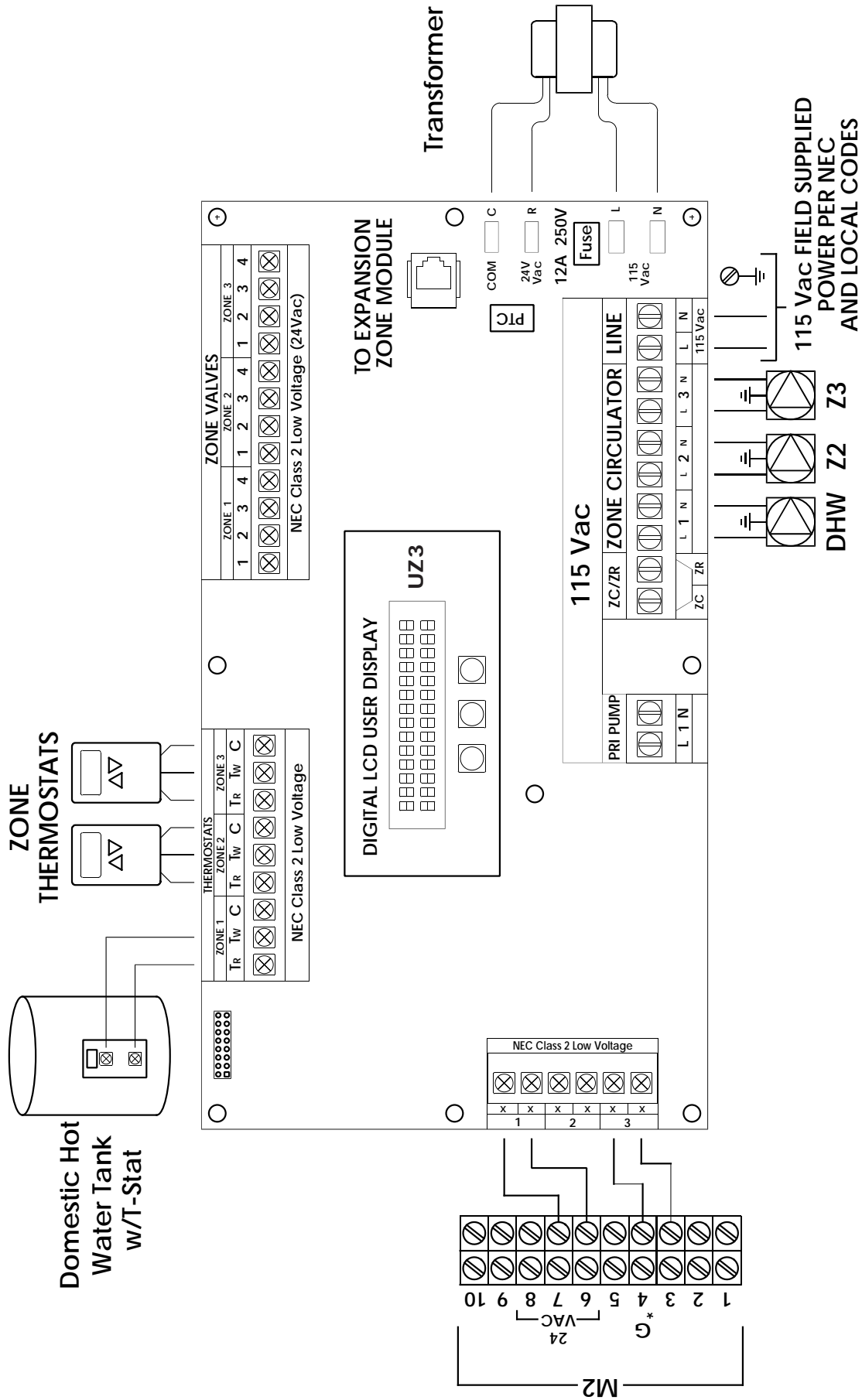
Reference zone control manufacturer instructions for details on setting priority if necessary.

# 165F WITH ZONE CIRCULATORS - PIPING DIAGRAM

## 165F WITH ZONE CIRCULATORS



165F ZONE CIRCULATORS, DHW TANK, & TANK T-STAT, ARGO UZ3 ZONE CONTROL

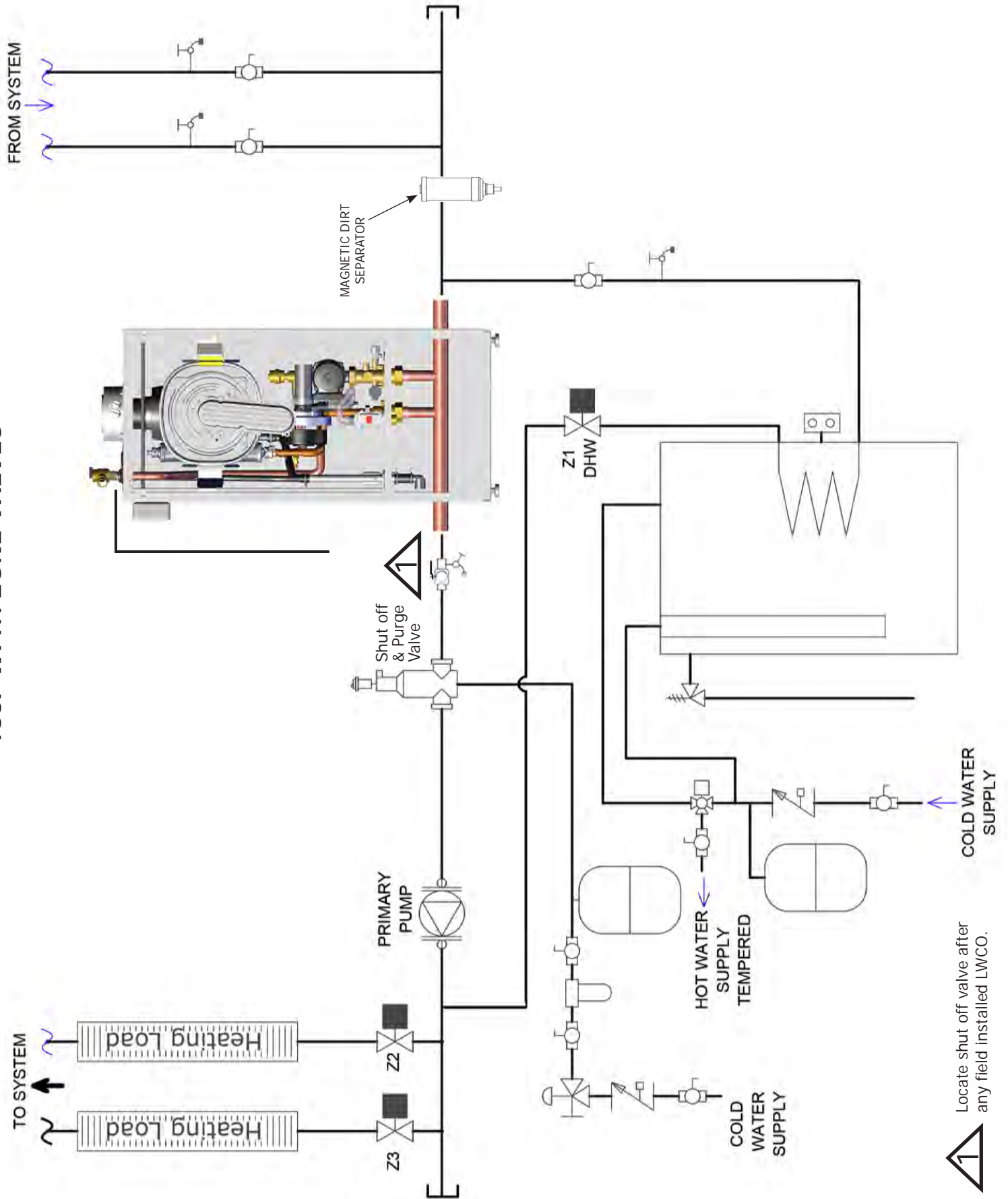


If adding an indirect tank with **Thermostat** to a **Heating Only Boiler**, change P03 from 08 to 04. See Section 9, Parameter Settings in Boiler Installation, Operation & Maintenance Manual for details.

Reference zone control manufacturer instructions for details on setting priority if necessary.

# 165F WITH ZONE VALVES - PIPING DIAGRAM

## 165F WITH ZONE VALVES



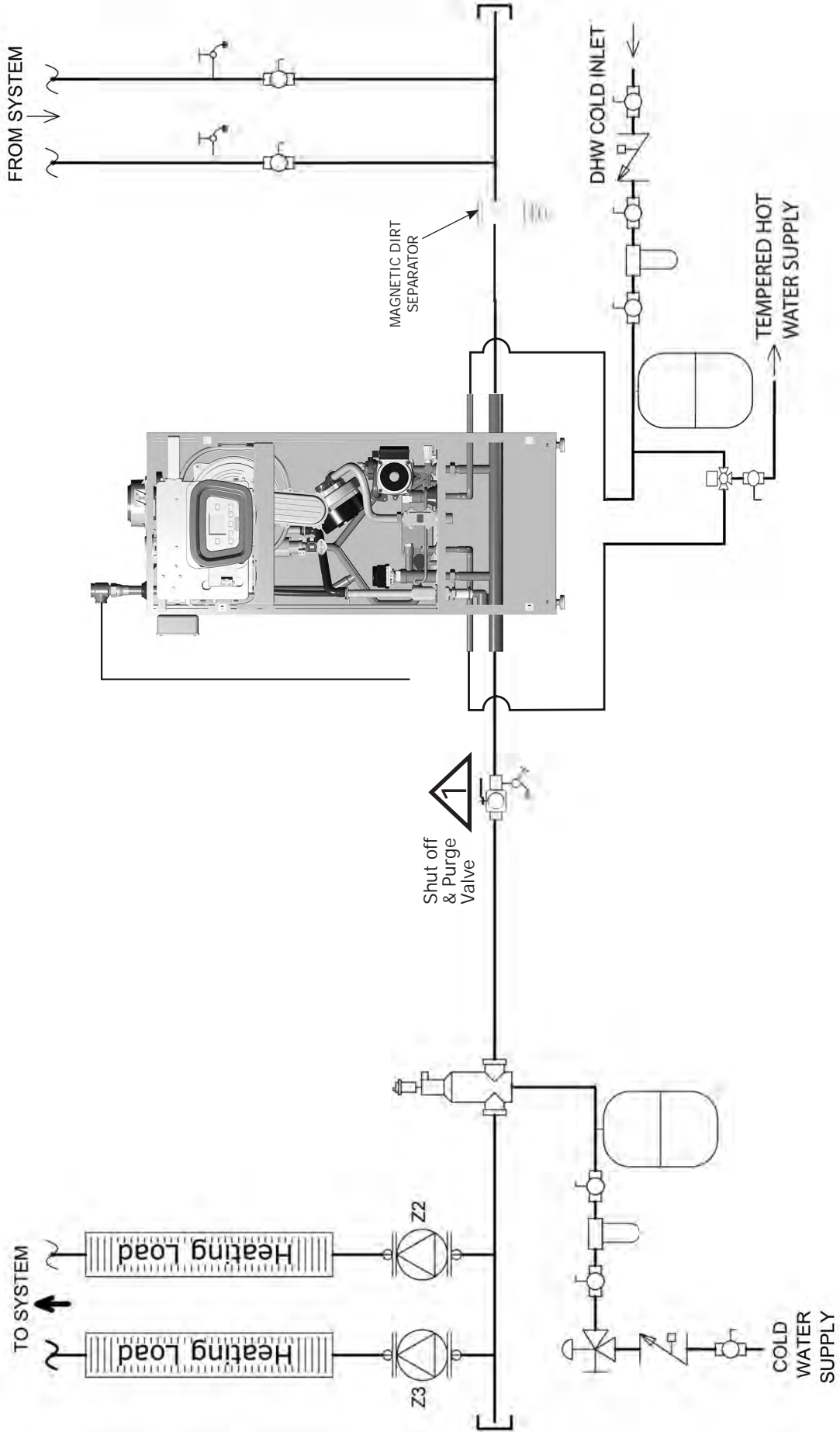
Locate shut off valve after any field installed LWCO.







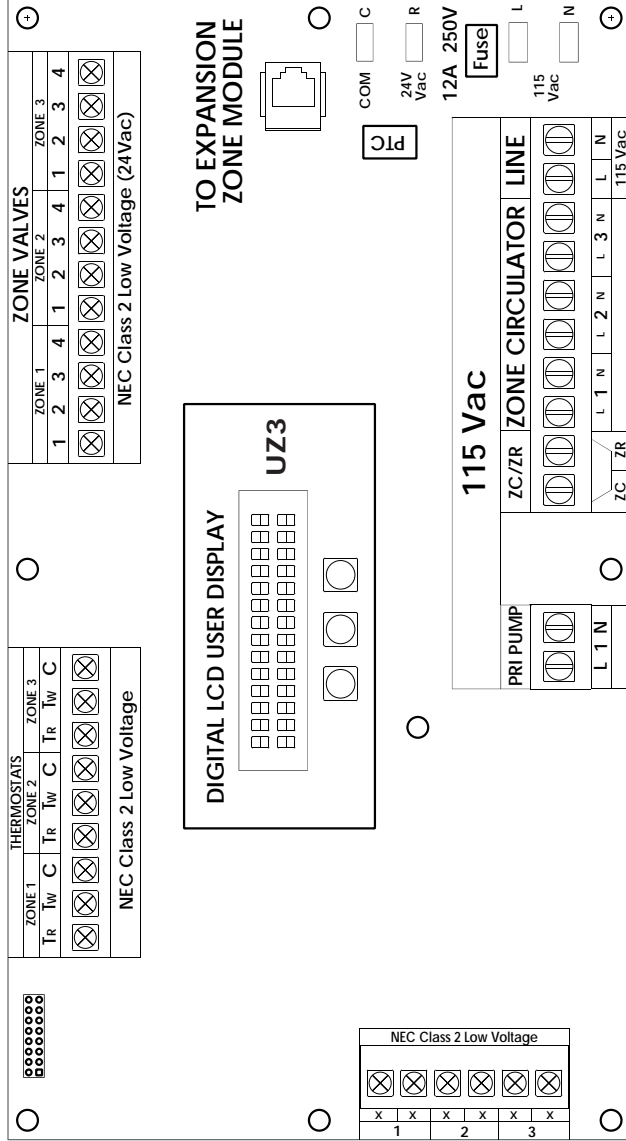
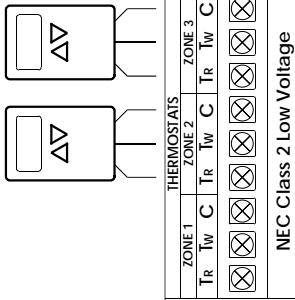
115F, 150F & 205F WITH ZONE CIRCULATORS



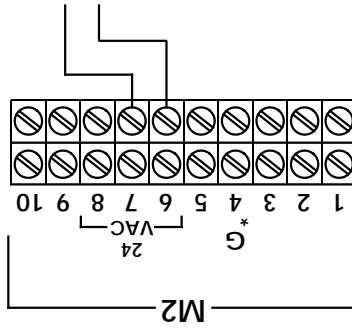
Locate shut off valve after any field installed LWCO.

115F, 150F & 205F WITH ZONE CIRCULATORS, ARGO UZ3 ZONE CONTROL

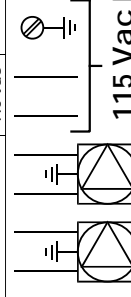
ZONE THERMOSTATS



M2 terminal strip on boiler

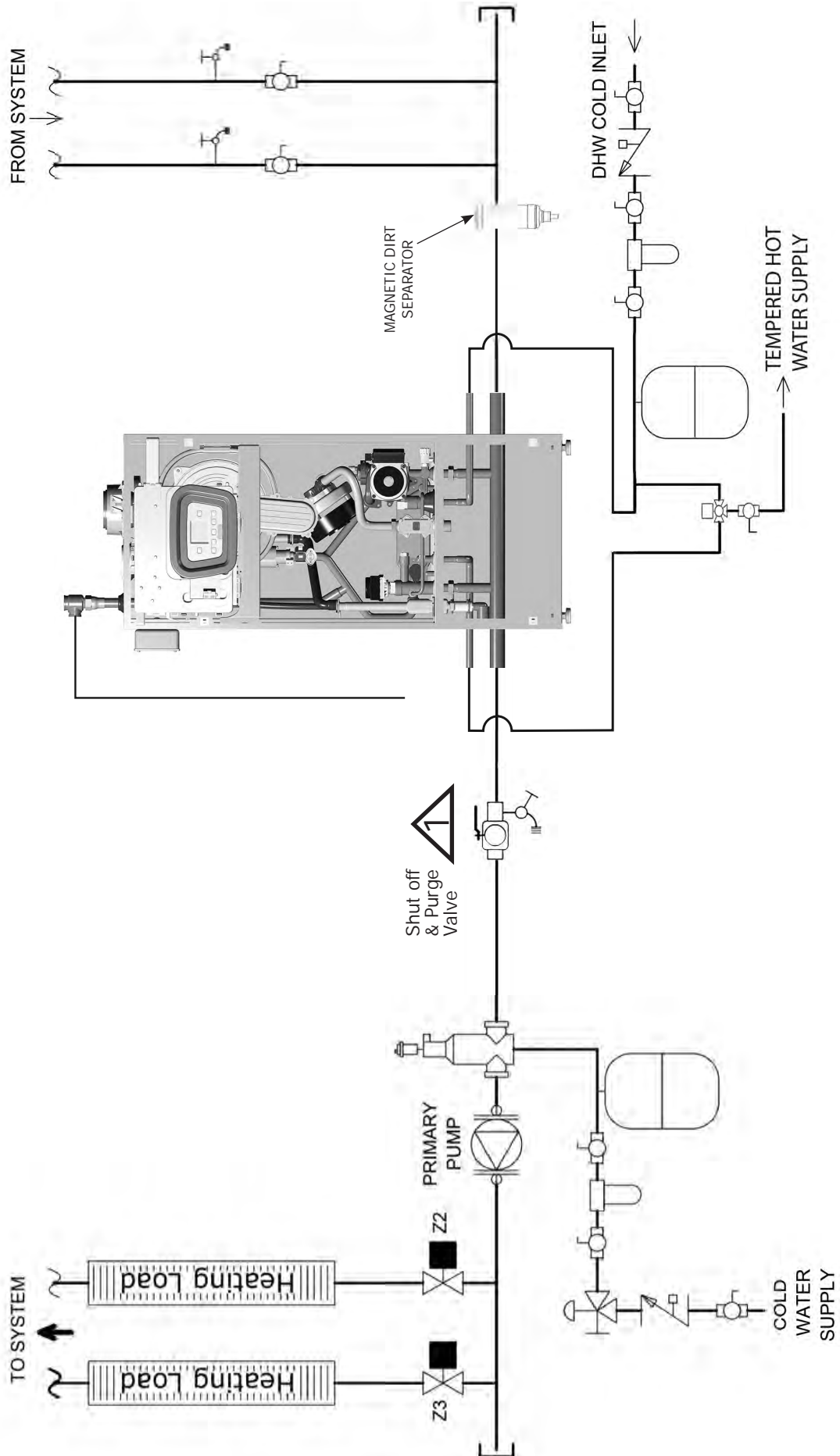


115 Vac FIELD SUPPLIED  
POWER PER NEC  
AND LOCAL CODES



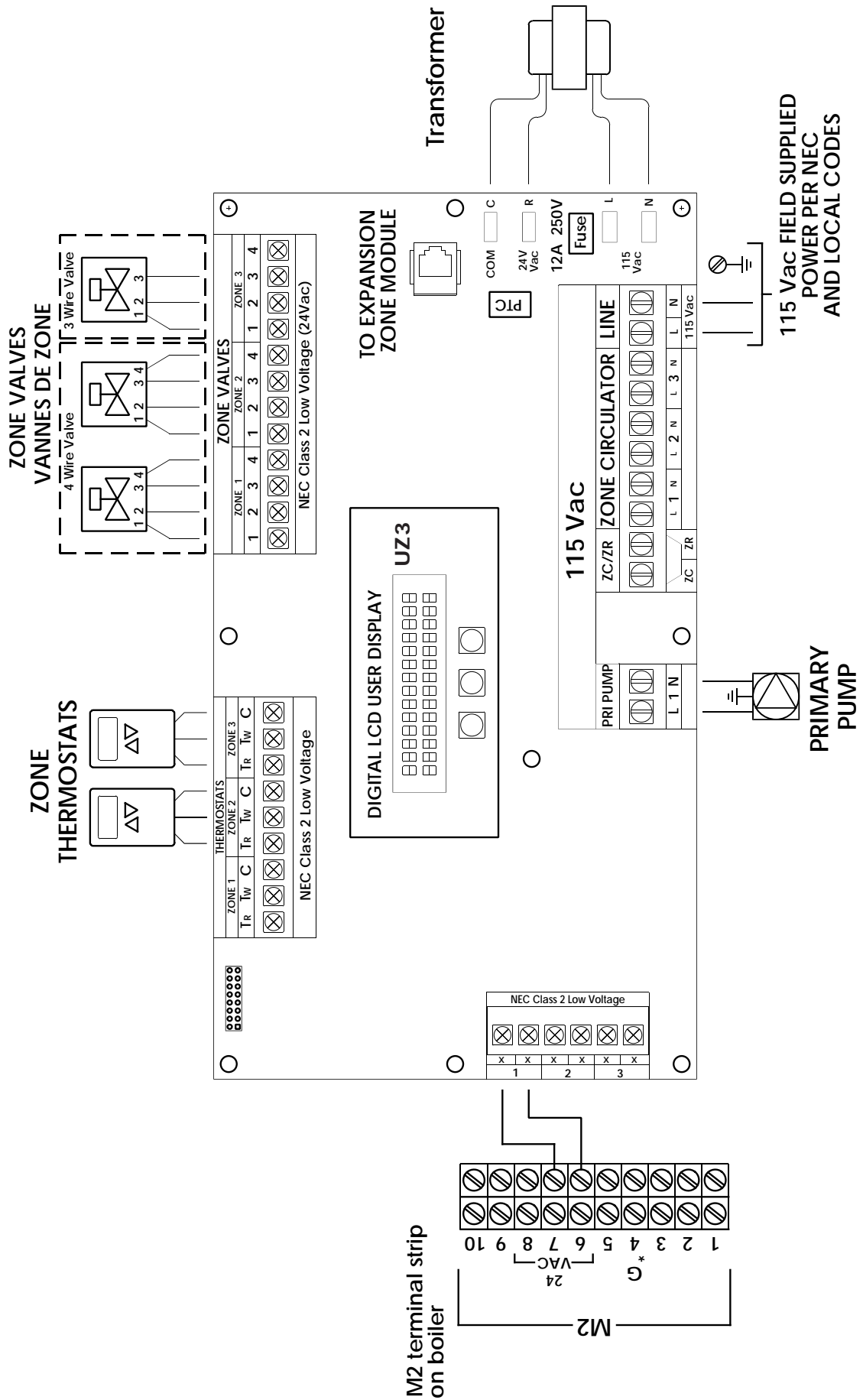
115F, 150F & 205F WITH ZONE VALVES - PIPING DIAGRAM

115F, 150F & 205F WITH ZONE VALVES



Locate shut off valve after any field installed LWCO.

115F, 150F & 205F WITH ZONE VALVES, ARGO UZ3 ZONE CONTROL



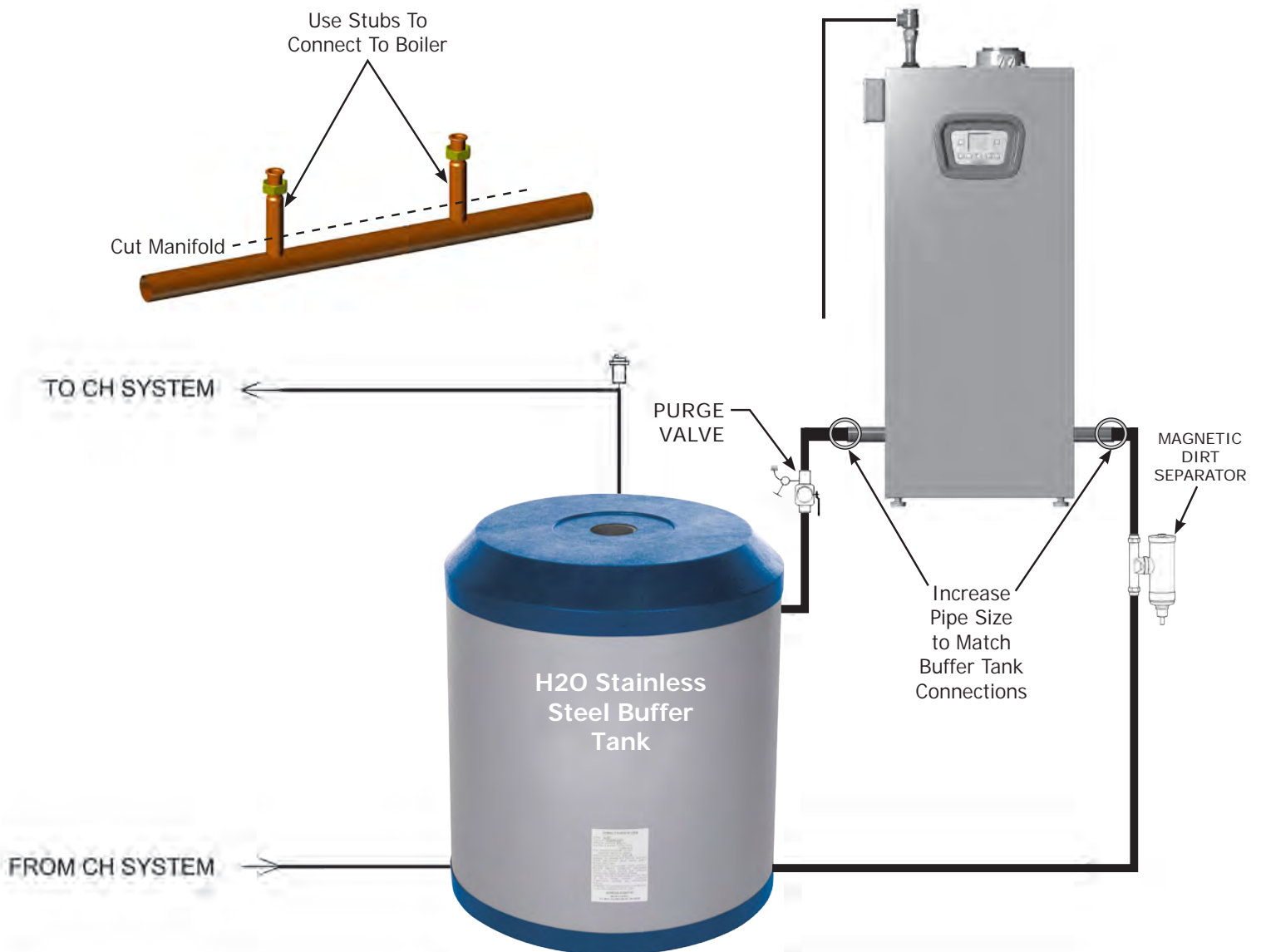
## Buffer Tank Piping

When installing low mass systems, additional water mass may be required to avoid short cycling by the boiler. In these applications it is recommended that a buffer tank be installed.

### Buffer Tank on Central Heat Circuit Using Internal Boiler Circulator

**Note:**

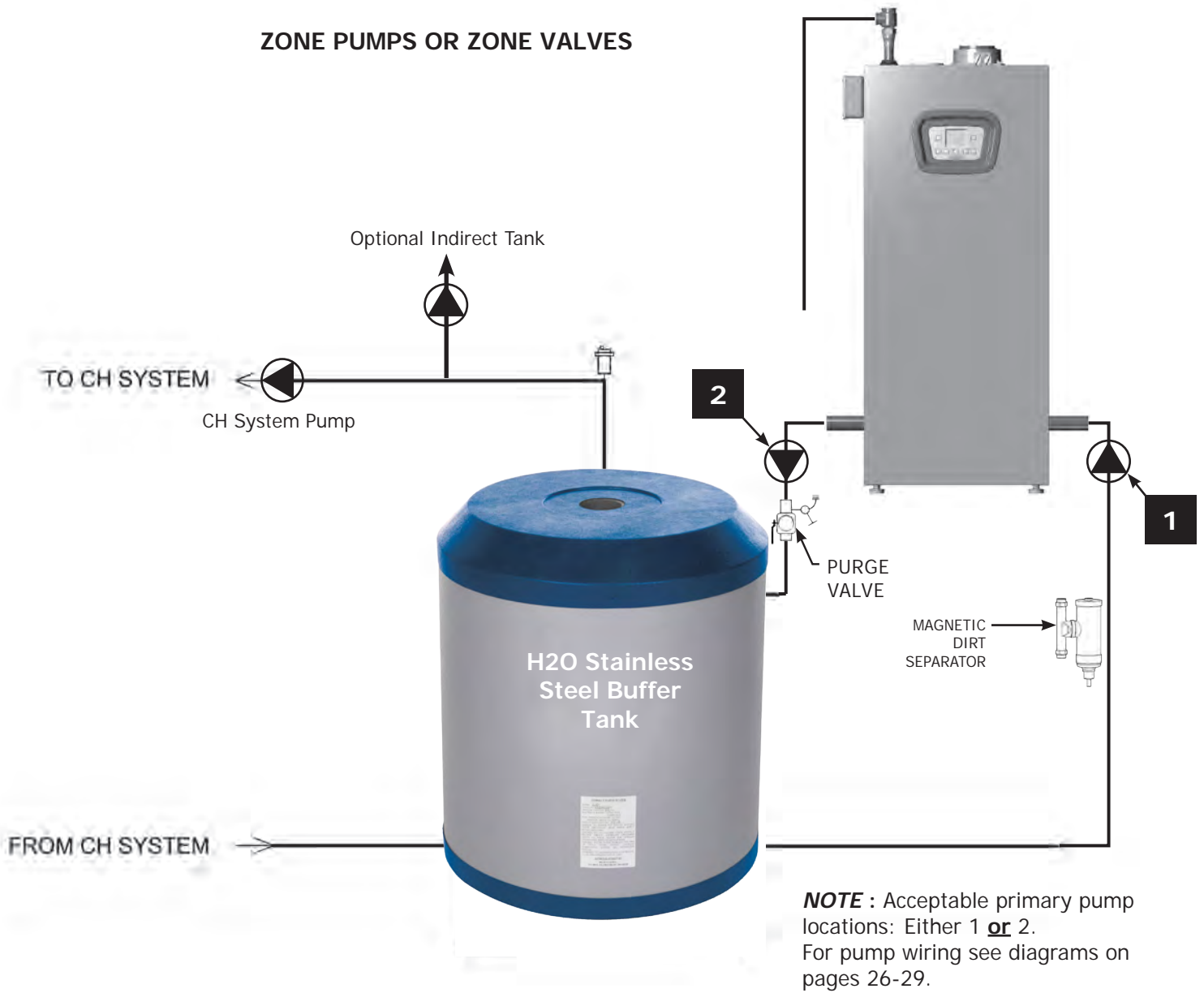
- DHW piping not shown for clarity. Reference applicable sections of this manual for DHW piping details.
- Internal Boiler circulator used on Primary circuit.





# EXTERNAL BUFFER TANK - PIPING DIAGRAM

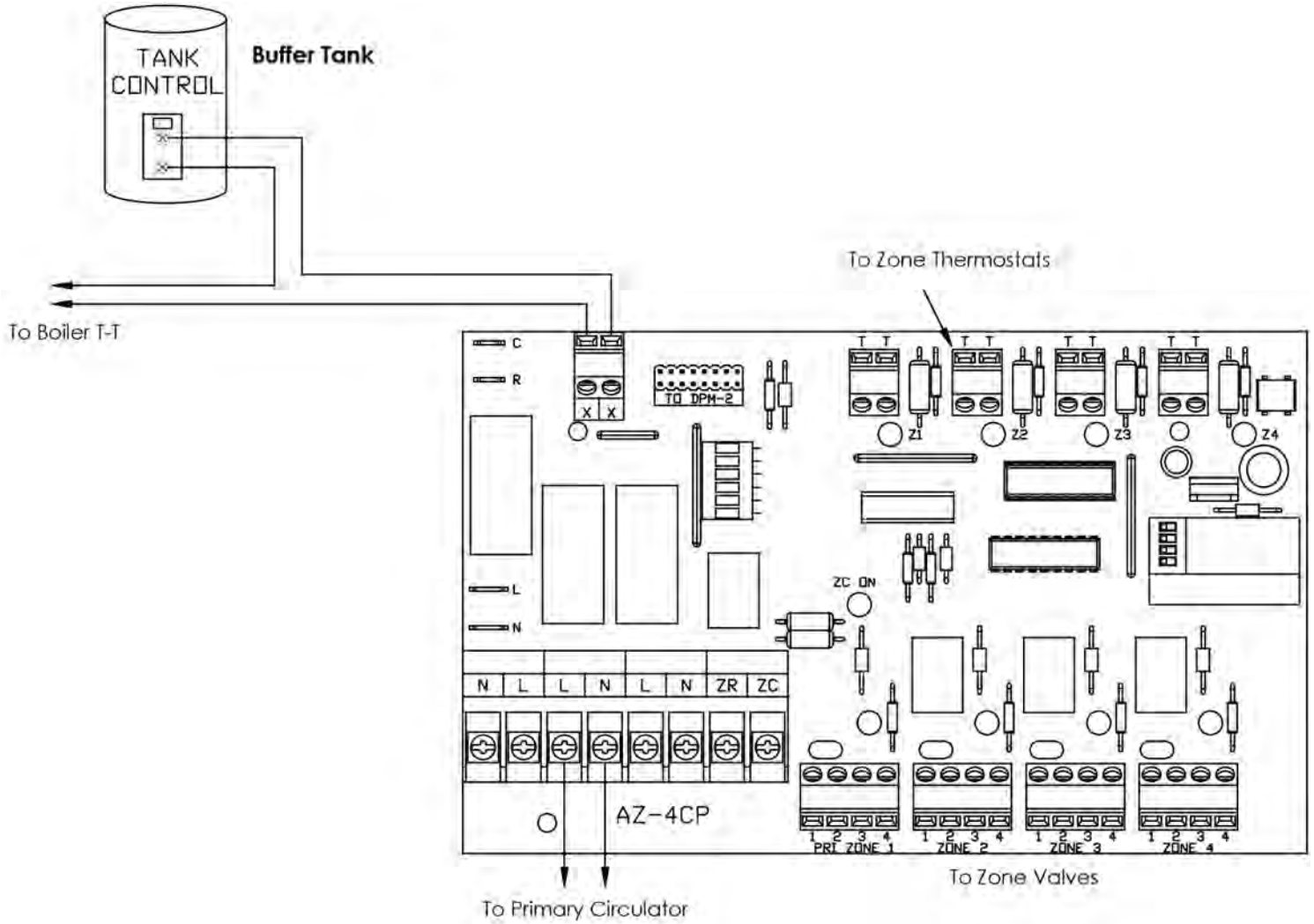
## Buffer Tank On Central Heat Circuit With Primary Pump and Supplied Manifold



# EXTERNAL BUFFER TANK - WIRING DIAGRAM

## Buffer Tank Pump Wiring

### Controlling A Primary Pump On A Combi Boiler With Zone Valves, No Indirect Tank

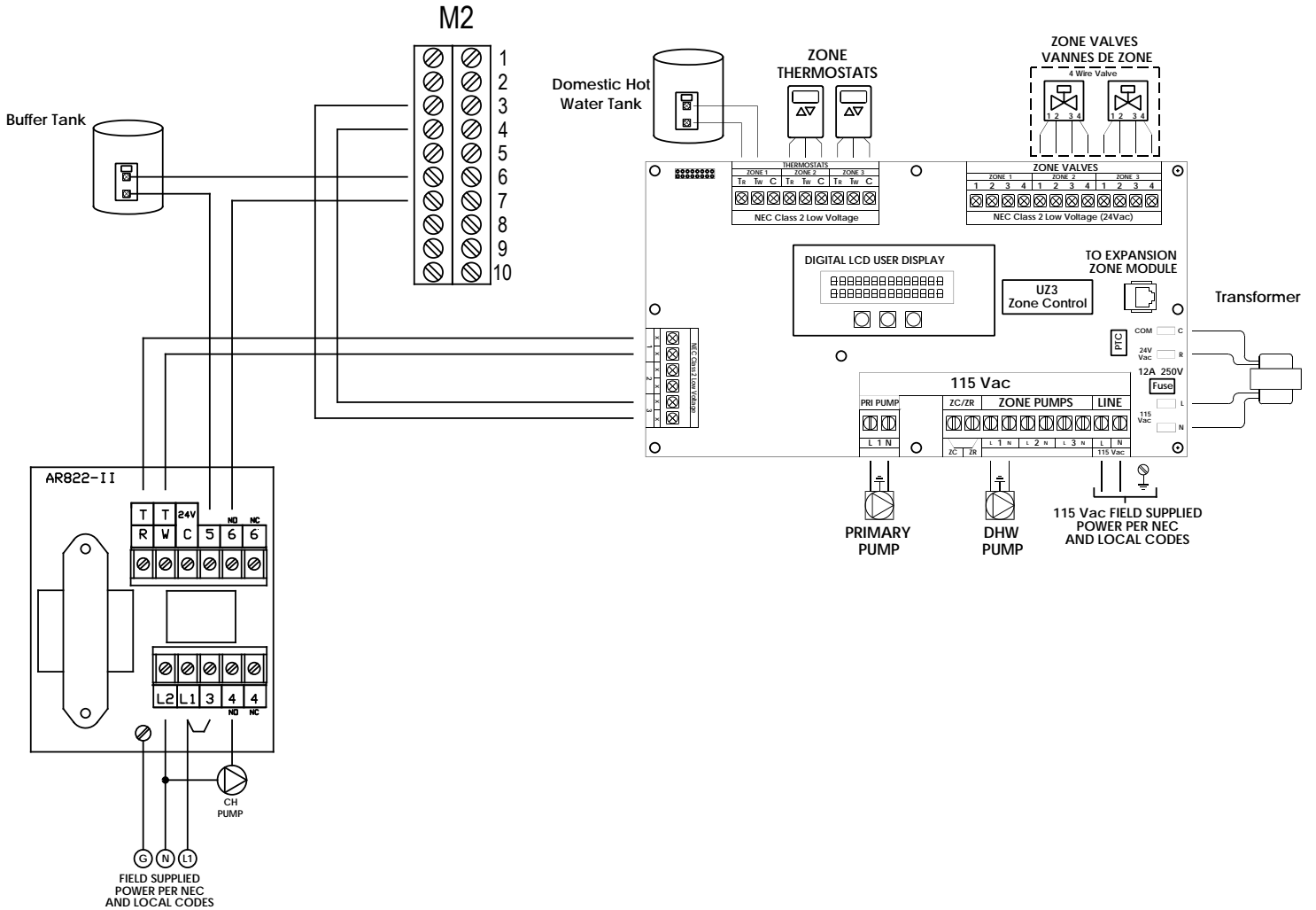




# EXTERNAL BUFFER TANK - WIRING DIAGRAM

## Buffer Tank Pump Wiring

### Controlling A Primary Pump On A Combi Boiler With Zone Valves and Indirect Tank With Priority, Argo UZ3 and AR822-II Zone Controls



## OPTIONAL EQUIPMENT

### Optional Equipment

**IMPORTANT:** Sensors supplied with this boiler are proprietary to the manufacturer. Use of alternate market sensors *WILL* diminish boiler performance.

1. **1k  $\Omega$**  Outdoor Air Sensor, if used.
  - A. Boiler automatically recognizes sensor when used.
  - B. See Chart 1 for sensor data. Sensor part number BD710487302V
  - C. Locate outdoor sensor to protect against wind and direct sunlight. Mounting instructions provided with sensor.
  - D. Maximum wire length is 100 ft (30m) for 22 ga. wire, or 150 ft (45m) for 18 ga. wire.
  - E. Connect wires to M2 OUTDOOR SENSOR terminals 4 & 5. Wires are interchangeable. See Accessories.
  
2. **10k  $\Omega$**  Sensor for Indirect DHW Tank (Heating Only Boiler, Exception: not applicable to the 165 model, use aquastat for indirect tank control.).
  - A. See Chart 2 for sensor data.
  - B. Connect wires to M2 terminals 3 & 4.

CHART 1 -1K $\Omega$ OUTDOOR AIR SENSOR DATA			
T [°F]	R [Ohm]	T [°F]	R [Ohm]
-4.0	7,578	53.6	1,690
-2.2	7,193	55.4	1,621
-0.4	6,831	57.2	1,555
1.4	6,489	59.0	1,492
3.2	6,166	60.8	1,433
5.0	5,861	62.6	1,375
6.8	5,574	64.4	1,321
8.6	5,303	66.2	1,268
10.4	5,046	68.0	1,218
12.2	4,804	69.8	1,170
14.0	4,574	71.6	1,125
15.8	4,358	73.4	1,081
17.6	4,152	75.2	1,040
19.4	3,958	77.0	1,000
21.2	3,774	78.8	962
23.0	3,600	80.6	926
24.8	3,435	82.4	892
26.6	3,279	84.2	858
28.4	3,131	86.0	827
30.2	2,990	87.8	796
32.0	2,857	89.6	767
33.8	2,730	91.4	740
35.6	2,610	93.2	713
37.4	2,496	95.0	687
39.2	2,387	96.8	663
41.0	2,284	98.6	640
42.8	2,186	100.4	617
44.6	2,093	102.2	595
46.4	2,004	100.4	617
48.2	1,920	102.2	595
50.0	1,840	104.0	575
51.8	1,763	106.0	556

CHART 2 -10K $\Omega$ INDIRECT TANK SENSOR DATA			
T [°F]	R [Ohm]	T [°F]	R [Ohm]
32.0	32,505	86.0	8,060
33.8	30,898	87.8	7,726
35.6	29,381	89.6	7,407
37.4	27,946	91.4	7,103
39.2	26,590	93.2	6,813
41.0	25,308	95.0	6,537
42.8	24,094	96.8	6,273
44.6	22,946	98.6	6,021
46.4	21,859	100.4	5,781
48.2	20,829	102.2	5,551
50.0	19,854	104.0	5,332
51.8	18,930	105.8	5,123
53.6	18,054	107.6	4,923
55.4	17,223	109.4	4,732
57.2	16,436	111.2	4,549
59.0	15,689	113.0	4,374
60.8	14,980	114.8	4,207
62.6	14,306	116.6	4,047
64.4	13,667	118.4	3,894
66.2	13,060	120.2	3,748
68.0	12,483	122.0	3,608
69.8	11,935	123.8	3,473
71.6	11,414	125.6	3,345
73.4	10,919	127.4	3,222
75.2	10,447	129.2	3,104
77.0	9,999	131.0	2,991
78.8	9,572	132.8	2,882
80.6	9,166	134.6	2,778
82.4	8,779	136.4	2,679
84.2	8,411	138.2	2,583

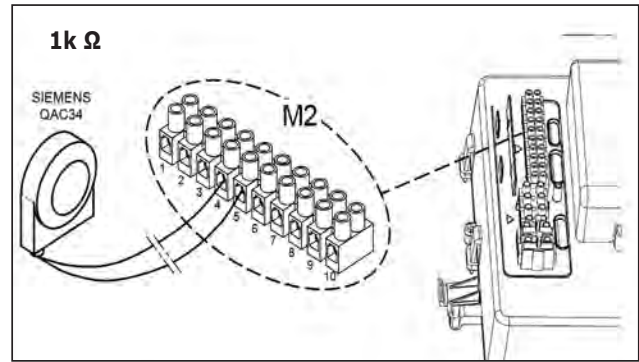


### 1. 1K Ohm (1k Ω) Outdoor Temperature Sensor Kit - BD710487302V

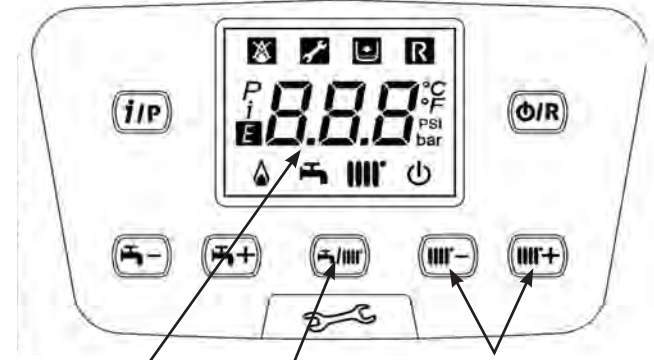
- Use the Outdoor Sensor (OAS) Kit with Heating Only or Combi Boilers.
- Wire Control to boiler M2 terminal strip, terminals 4 and 5 as shown.
- Install/locate Control follow supplied instructions with sensor kit and Installation, Operation and Maintenance Manual (IOM).

#### Setting "Kt" Climate Curve:

1. Boiler automatically recognizes OAS sensor when wired to M2 terminal block. Display changes to show current default "Kt" value (80). Note display value.
2. When operating in CH mode, boiler setpoint is determined by the **Kt** value selected and actual outside air temperature. Refer to applicable °F (or °C) chart, (pg. 30) for setpoint information.
  - Select **Kt** range which will satisfy the desired boiler delivery temperature based on outdoor temperature range expected for your location. For example: if you need 176°F water when the outside temperature is 20°F and colder, select 35 for your **Kt** setting.
  - To change "default" **Kt** value on boiler control use or CH Heating buttons.
  - Restrict the upper limit of the **Kt** curve by using Parameter P16 to set the maximum boiler water temperature. P16 Default is 176°F.
3. When OAS is installed, pressing or buttons will no longer display boiler CH setpoint temperature. It now displays the **Kt** value which can range from 10 to 90.
4. When scrolling has stopped, boiler will automatically "SAVE" value as new **Kt** default value and automatically return to CH mode when no **Kt** adjustment activity is sensed. **Kt** values can be changed in +/- 1 point increments.
5. To return, to verify or change current **Kt** "default value, depress one of the CH setpoint adjustment buttons (once), or , while in any heating or standby mode. Adjust **Kt** value to obtain desired comfort level.

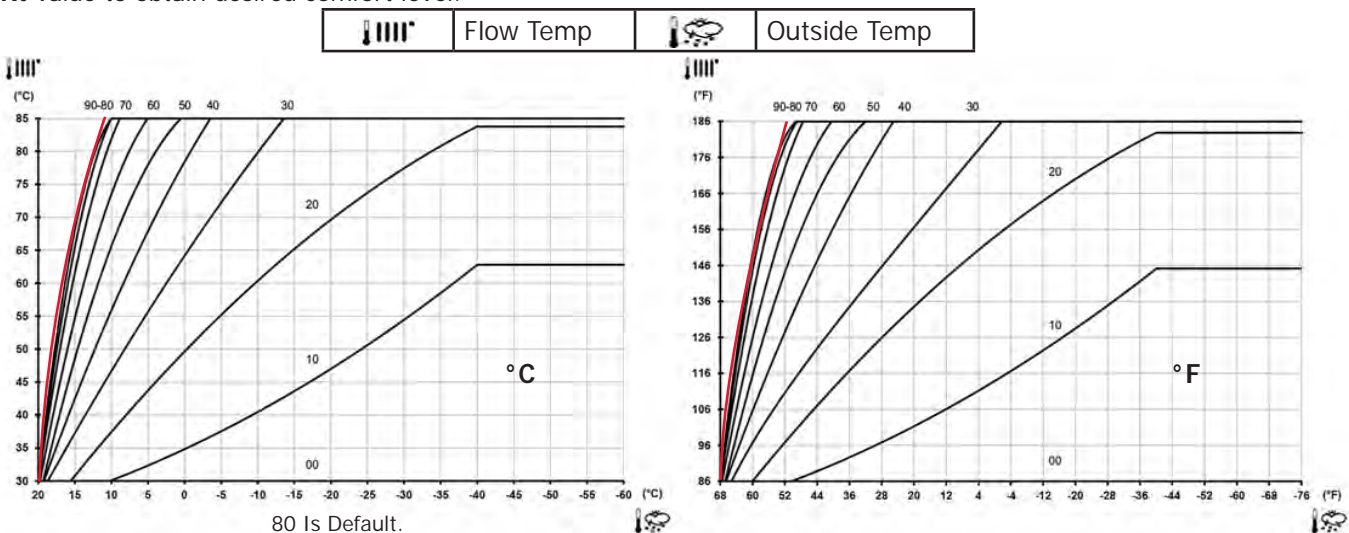


Boiler Control Panel



#### BUTTONS Key

	DHW temperature adjustment (+ to increase the temperature and - to decrease it)
	Heating water temperature adjustment (+ to increase the temperature and - to decrease it)
	Boiler operating information
	Operating mode: DHW – DHW & Heating – Heating Only
	Off – Reset – Exit menu/functions



**Note** For temperatures below -40°F (-40°C), maximum heating flow temperature set point no longer increases and curves on the graph become horizontal. Boiler set point will override sensor setpoint.





## 2. 10k Ω Indirect Storage Tank Sensor Kit

Heating Only boiler can be electrically connected to Indirect Storage Tank.

Diagram of electrical connection of external indirect storage tank is shown below.

Connect DHW priority sensor to terminals 3 and 4 on terminal block M2. The element of the sensor must be inserted in the sensor well located on the indirect storage tank.

Verify the exchange capacity of the indirect tank coil is appropriate for power of the heating only boiler. Adjust DHW temperature (+95°F...+140°F / +35°C...+60°C) by pressing   buttons on boiler control panel.



Parameter PO3 for **Heating Only** boiler, with no indirect tank remains Factory Set at 08. No change is required.

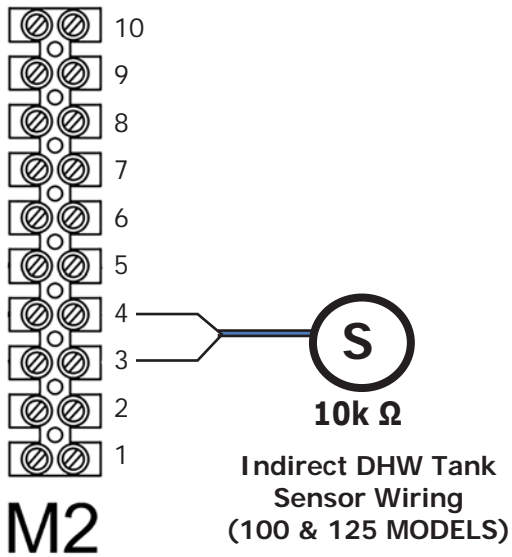
If adding an Indirect Tank with a sensor to **Heating Only Boiler** - change PO3 parameter from 08 to 05.

If adding an Indirect Tank with a thermostat to **Heating Only Boiler** - change PO3 parameter from 08 to 04.

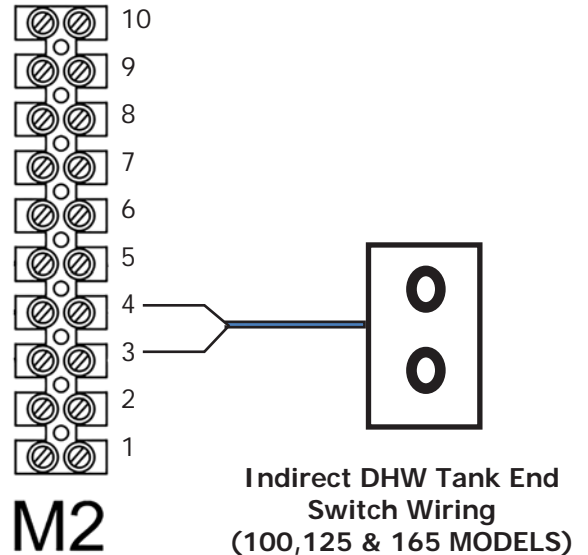
See Section 9, Parameter Settings, in boiler's Installation, Operation, and Maintenance Manual.

Parameter PO3 for **COMBI** boiler factory set at 00 requires no change.

Electrical Connection Heating Only Boiler



Electrical Connection Heating Only Boiler



### Management of 0-10V Input

To activate the 0-10v function **parameter 82** must be set to **3**.

There must be at or above 3 V DC present for the control to recognize a call for heat.

When **P78 = 1** the 0-10v input manages CH heating setpoint directly per chart below.

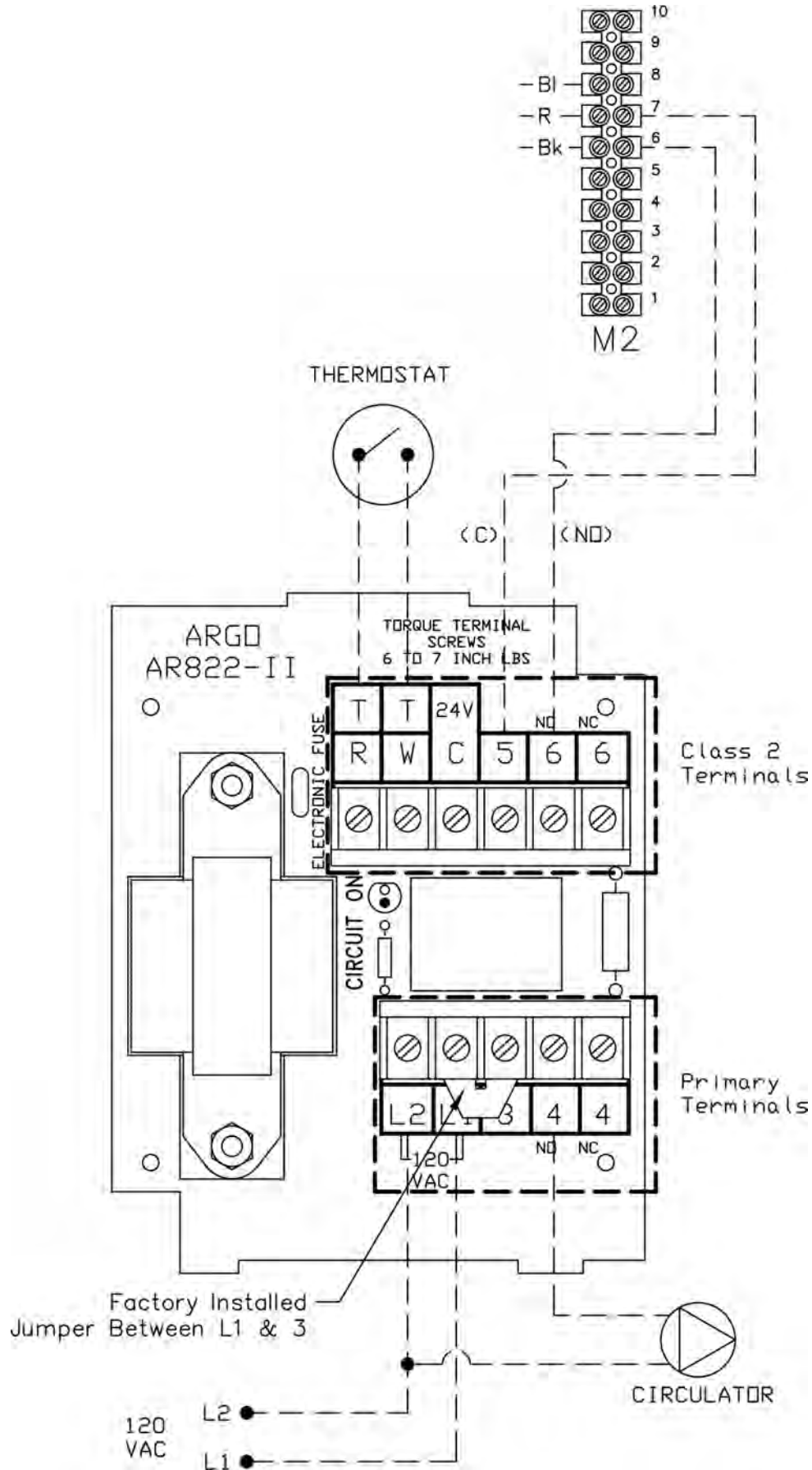
When **P78 = 2** the 0-10v input manages CH heating input directly per chart below.

When **P78 = 0** Disabled

Voltage	P78=1		P78 = 2							
	Temp Setting		75		100/115		125/150		165/205	
	°C	°F	kW	MBH	kW	MBH	kW	MBH	kW	MBH
0-3	OFF									
3	25	77	4.9	16.6	4.9	16.6	6.4	22.0	8.6	29.5
4	32	90	7.3	24.9	8.4	28.9	10.7	36.5	14.4	49.0
5	40	104	9.7	33.3	12.0	40.8	14.9	51.0	19.9	68.0
6	49	120	12.2	41.6	15.4	52.4	19.2	65.5	25.5	87.0
7	57	135	14.7	50.0	18.5	63.1	23.4	80.0	31.1	106.0
8	65	149	17.1	58.3	22.2	75.7	27.7	94.5	36.6	125.0
9	73	163	19.5	66.6	25.3	86.2	31.9	109.0	42.5	145.0
10	80	176	21.2	75.0	27.4	93.6	36.9	125.0	48.1	164.0

# CIRCULATOR CONNECTIONS - WIRING DIAGRAM

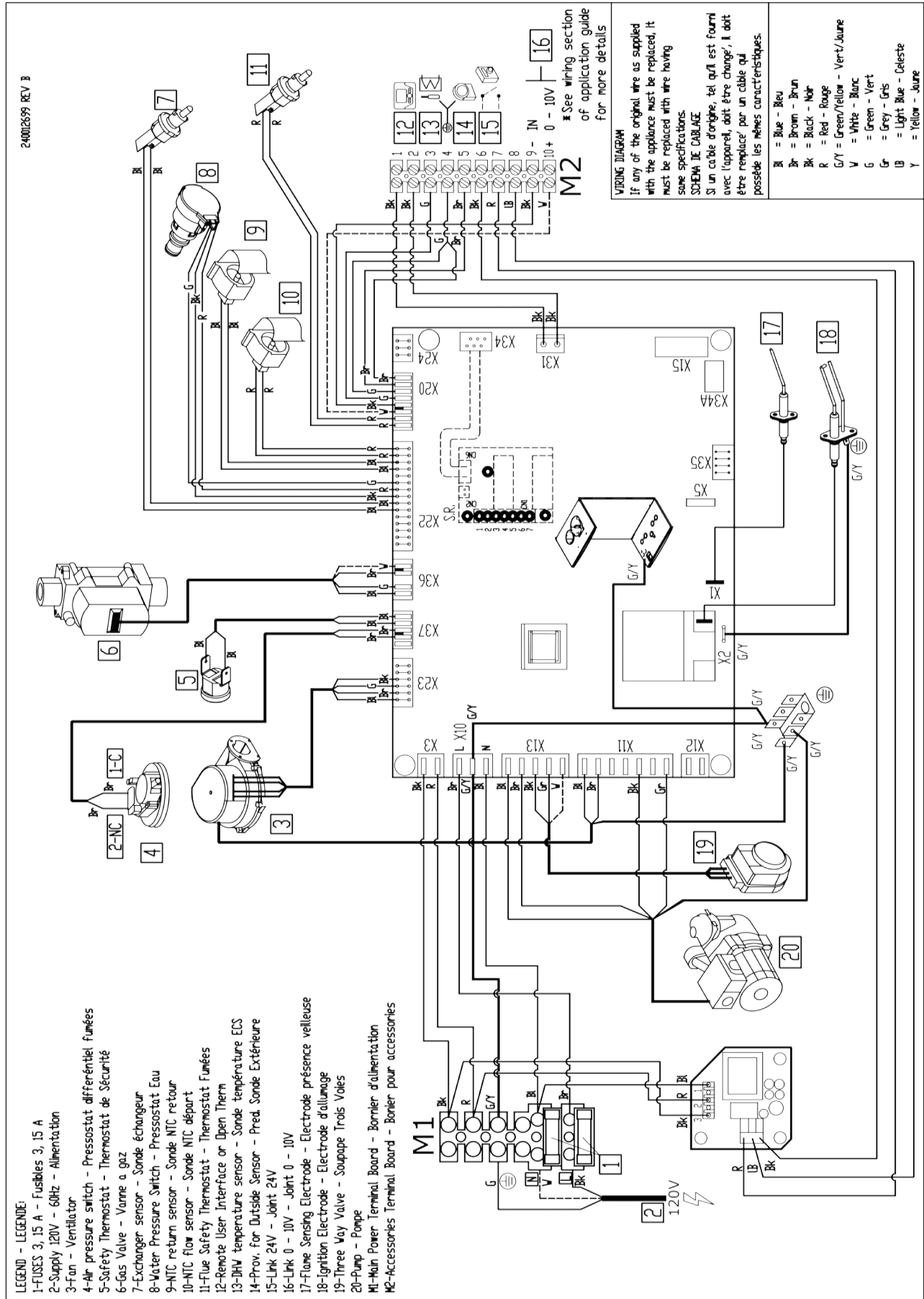
## SINGLE ZONE CIRCULATOR WIRING USING ARGO AR822-II





# 125 - HEAT ONLY WIRING DIAGRAM

## MODEL 125 - HEAT ONLY



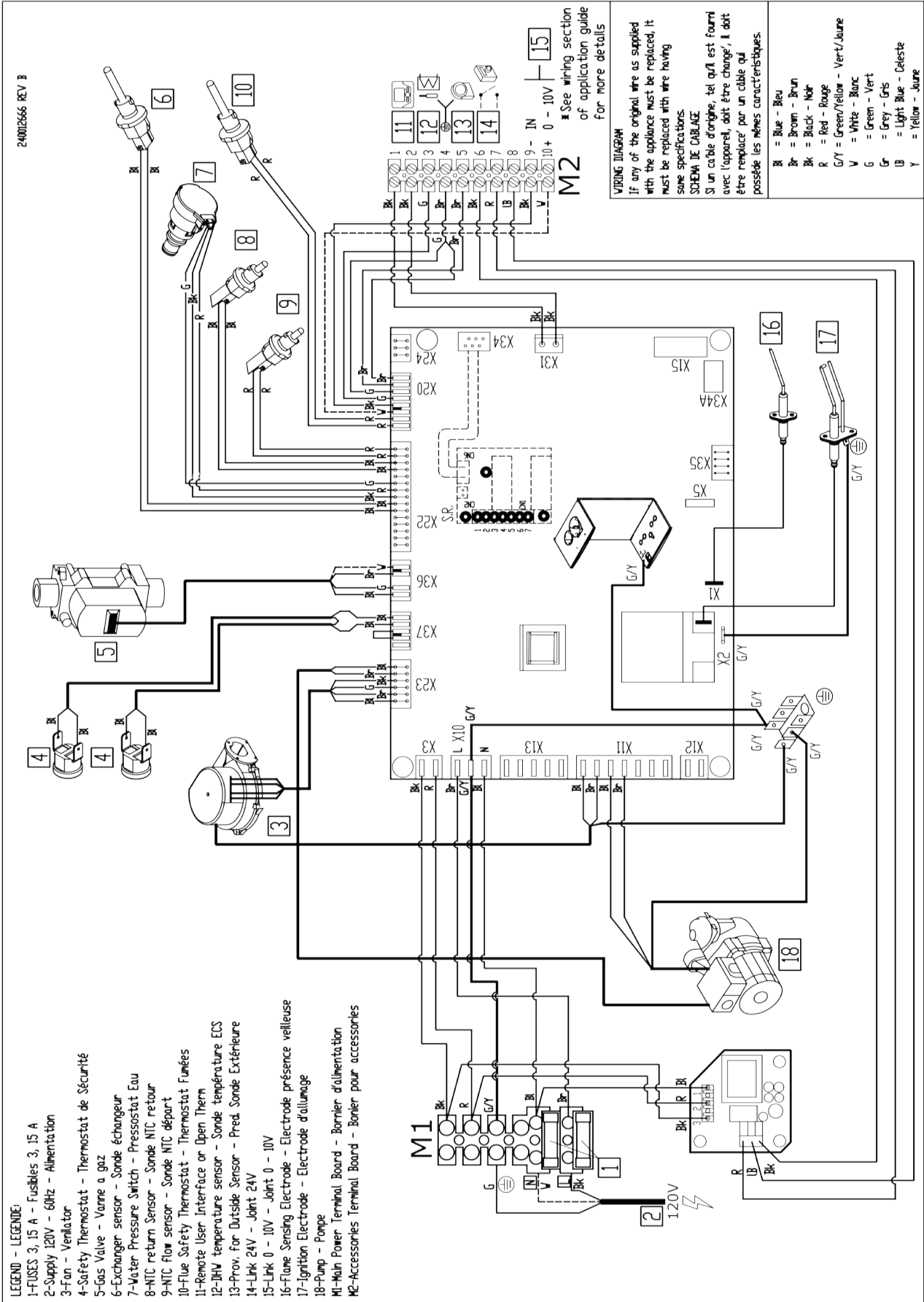
# 165 - HEAT ONLY WIRING DIAGRAM

## MODEL 165 - HEAT ONLY

240012666 REV. B

**LEGEND - LEGENDE:**

- 1-FUSES 3, 15 A
- 2-Supply 120V - 60Hz - Alimentation
- 3-Fan - Ventilator
- 4-Safety Thermostat - Thermostat de Sécurité
- 5-Gas Valve - Vanne à gaz
- 6-Exchanger sensor - Sonde échangeur
- 7-Water Pressure Switch - Pressostat Eau
- 8-NTC return sensor - Sonde NTC retour
- 9-NTC flow sensor - Sonde NTC départ
- 10-Flue Safety Thermostat - Thermostat Fumées
- 11-Remote User Interface or Open Therm
- 12-10W temperature sensor - Sonde température ECS
- 13-Proc. for Outside Sensor - Pred. Sonde Extérieure
- 14-Link 24V - Joint 24V
- 15-Link 0 - 10V - Joint 0 - 10V
- 16-Flame Sensing Electrode - Electrode présence veilleuse
- 17-Ignition Electrode - Electrode d'allumage
- 18-Pump - Pompe
- M1-Main Power Terminal Board - Bornier d'alimentation
- M2-Accessories Terminal Board - Bornier pour accessoires



**WIRING DIAGRAM**

If any of the original wire as supplied with the appliance must be replaced, it must be replaced with wire having same specifications.

SCHEMA DE CABLAGE  
Si un câble d'origine, tel qu'il est fourni avec l'appareil, doit être changé, il doit être remplacé par un câble qui possède les mêmes caractéristiques.

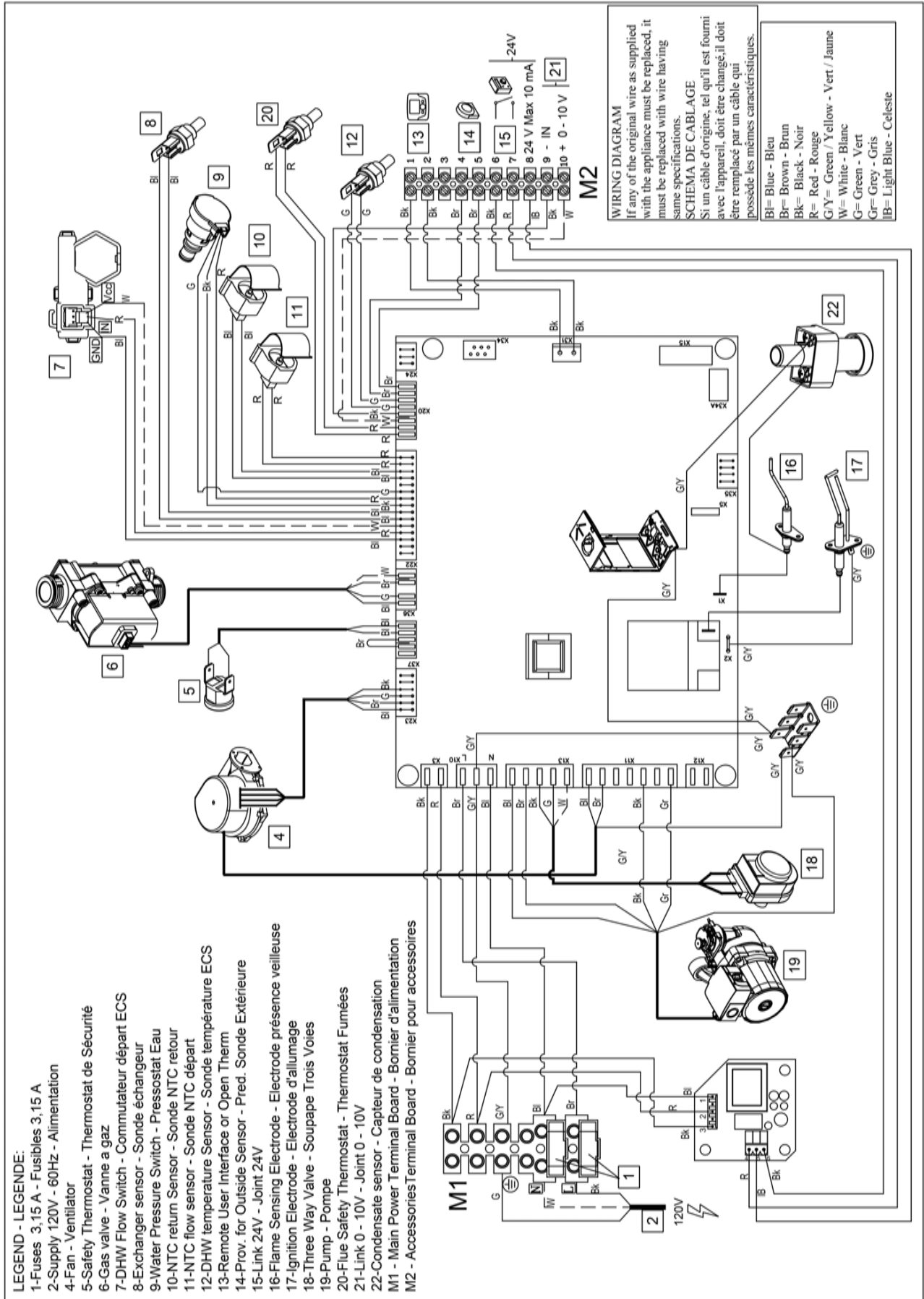
- Bk = Blue - Bleu
- Br = Brown - Brun
- Bk = Black - Noir
- R = Red - Rouge
- G/Y = Green/Yellow - Vert/Jaune
- V = White - Blanc
- G = Green - Vert
- Gr = Grey - Gris
- LB = Light Blue - Céleste
- Y = Yellow - Jaune

\*See wiring section of application guide for more details



# 115 - COMBI WIRING DIAGRAM

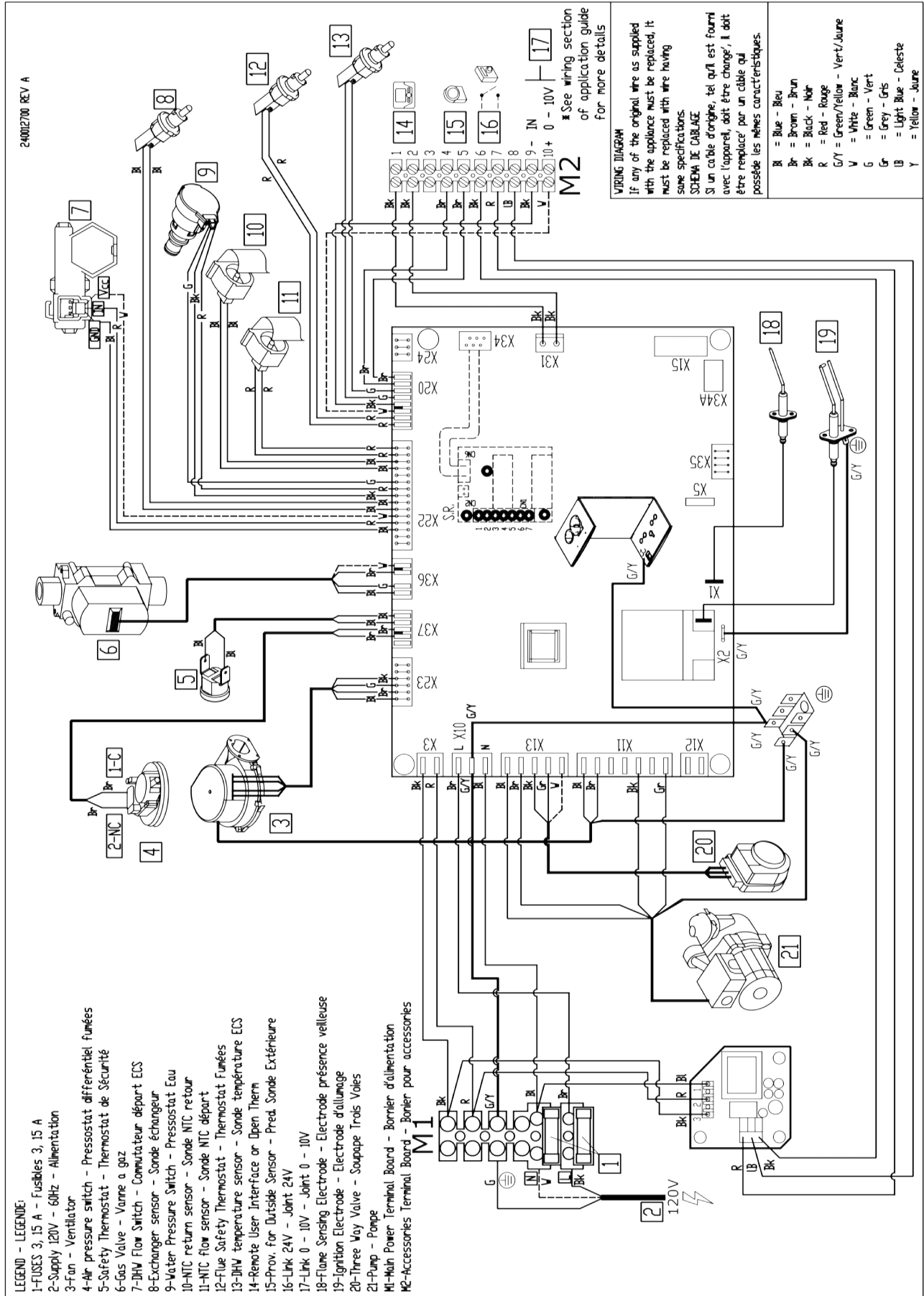
## MODEL 115 - COMBI





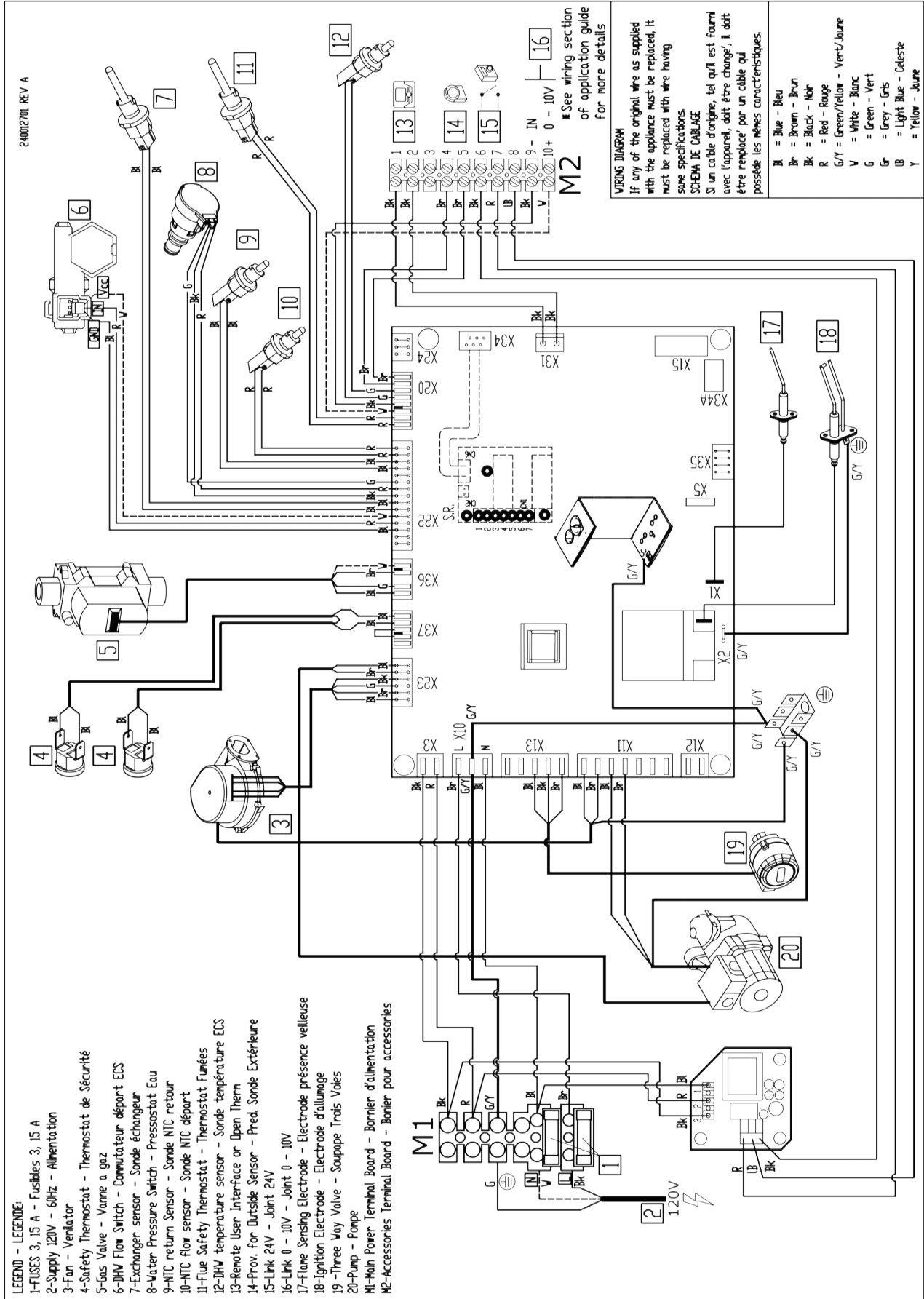
# 150 - COMBI WIRING DIAGRAM

## MODEL 150 - COMBI

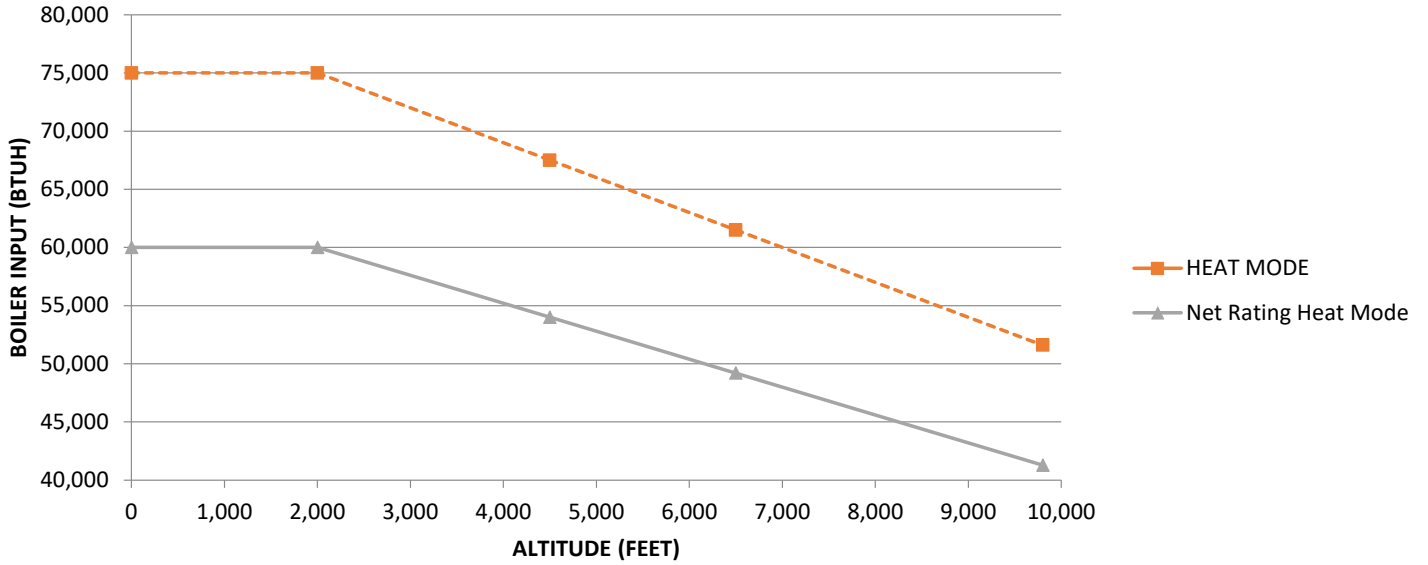


# 205 - COMBI WIRING DIAGRAM

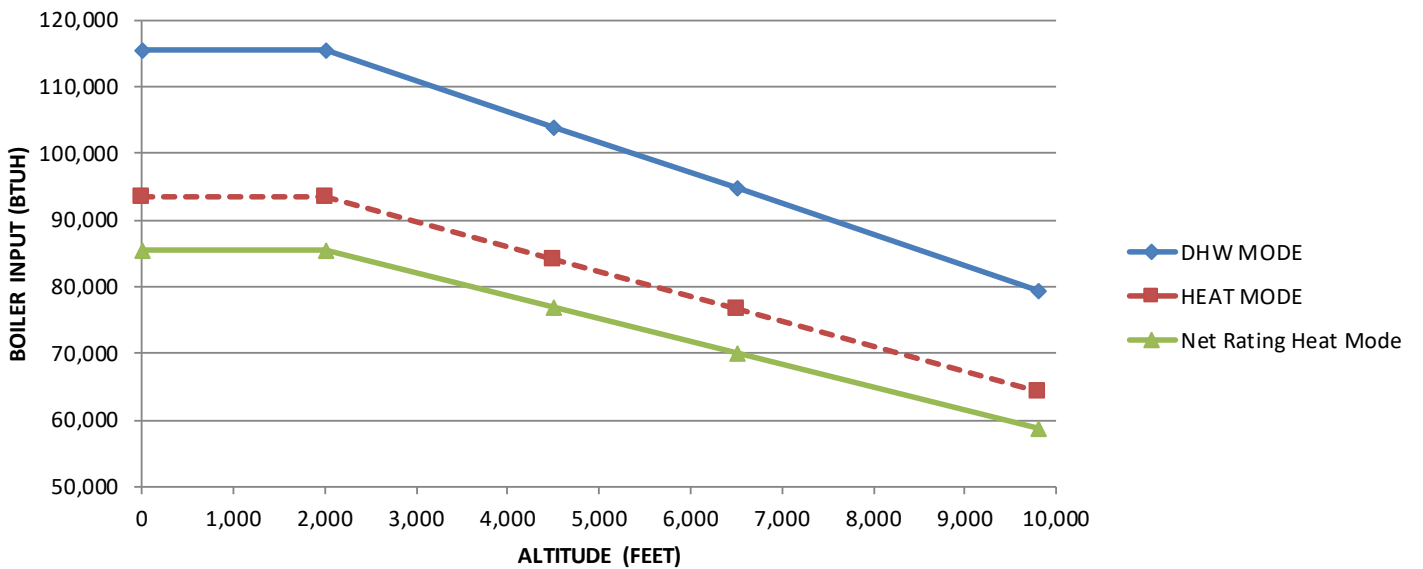
## MODEL 205 - COMBI



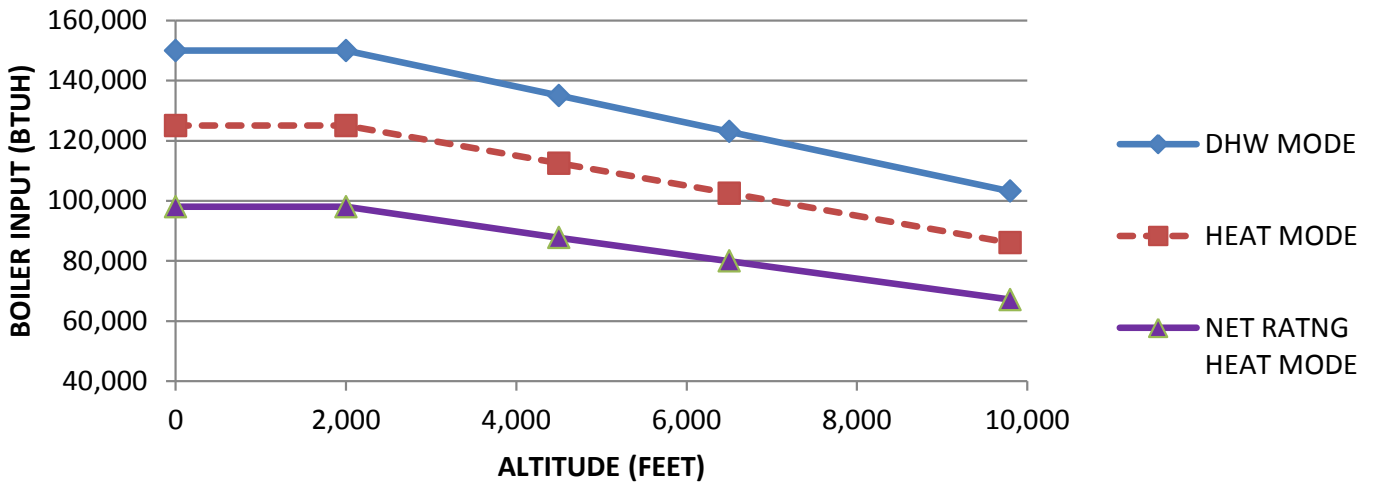
**MODEL 75  
CALCULATED EFFECTS OF HI-ALTITUDE ON BOILER  
PERFORMANCE**



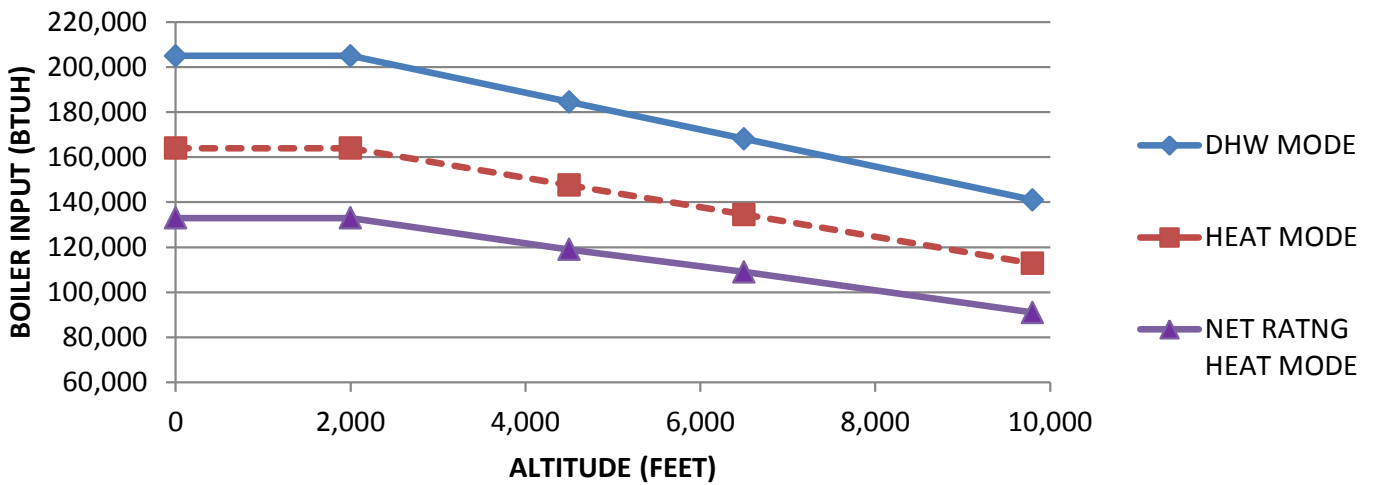
**MODELS 100/115  
CALCULATED EFFECTS OF HI-ALTITUDE ON BOILER  
PERFORMANCE**



### MODELS 125/150 CALCULATED EFFECTS OF HI-ALTITUDE ON BOILER PERFORMANCE



### MODELS 165/205 CALCULATED EFFECTS OF HI-ALTITUDE ON BOILER PERFORMANCE



**APPLICATION TABLE - INDIRECT HOT WATER TANK PERFORMANCE CHART**

**HEATING ONLY BOILERS 75, 100, 125, 165**

Model	Max. First Hour Rating		Continuous Rating		Boiler Output Needed For Maximum Performance  (BTU/Hr)	Boiler Water Flow Through Coil  Gal/Min	Pressure Drop Through Coil  (Ft. Water)
	Gal/Hr. @		Gal/Hr @				
	140 F	115 F	140 F	115 F			
H2OI30	176	233	149	206	112,000	14.0	5.7
H2OI40	193	254	157	218	118,000	14.0	5.9
H2OI40L	186	251	150	215	116,000	14.0	5.6
H2OI50	196	254	151	231	125,000	14.0	6.2
H2OI60	231	298	177	244	132,000	14.0	6.4
H2OI60L	211	272	157	218	118,000	14.0	5.9
H2OI80	241	306	169	234	127,000	14.0	6.2
H2OI115	291	363	188	260	141,000	14.0	6.7
<b>High Output Units 60HO, 80HO, and 115HO</b>							
H2OI60HO	353	468	299	414	221,000	14.0	10.5
H2OI80HO	366	479	294	407	220,000	14.0	10.3
H2OI80HOC	386	507	314	435	236,000	21.0	15.8
H2OI15HO	413	532	310	429	232,000	14.0	10.8
H2OI115HOC	423	545	320	442	240,000	21.0	16.7
<b>Extra High Output Units 85XHO and 115XHO</b>							
H2OI85XHOC	649	868	571	790	428,000	28.0	13.0
H2OI115XHOC	674	893	571	790	428,000	28.0	13.0

**Notes:**

**176 °F Boiler Supply Water Temperature, AHRI Conditions -50 °F Inlet Water @ 240 GPH Flow Rate.**

## LOW WATER CUTOFF

### Low Water Cut Off - Heating Only and Combi Boilers

These guidelines are supplied when necessary to install an additional Low Water Cut Off (LWCO), for sensing a low water level condition in a boiler, as required by the Authority Having Jurisdiction.

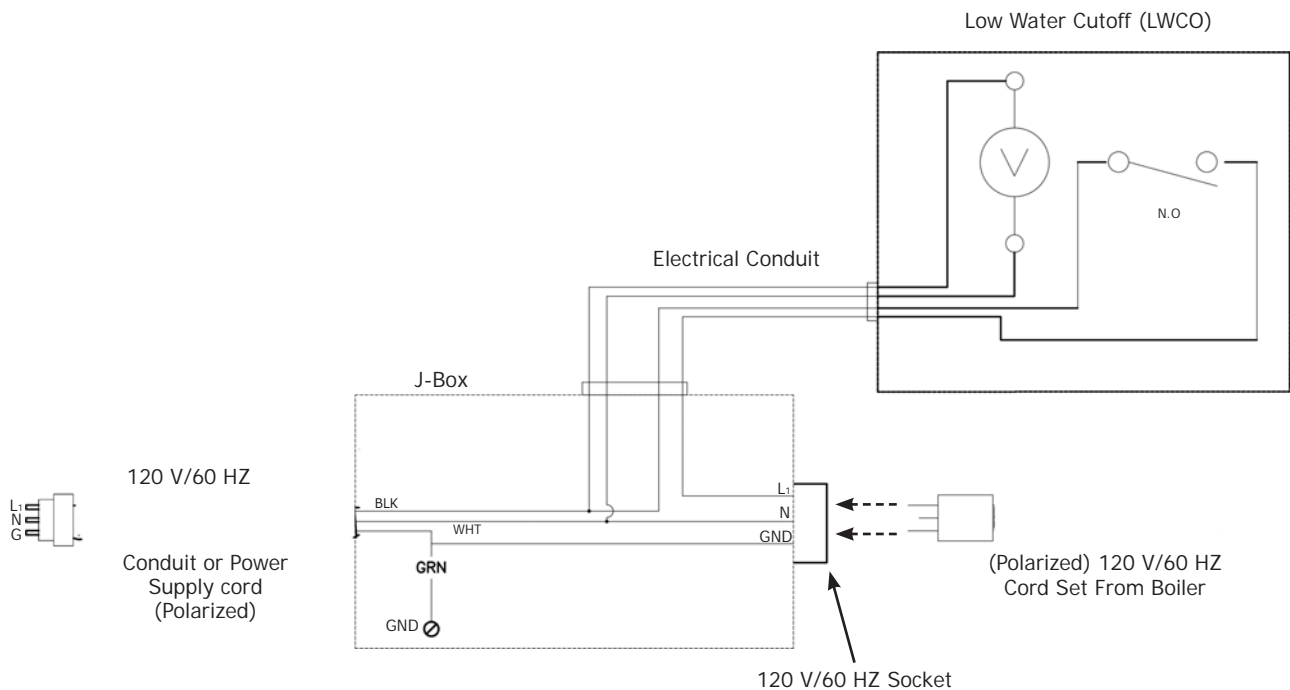
Follow LWCO manufacturer installation instructions for type of LWCO selected in addition to these instructions.

LWCO shall be 120V/60HZ control and dry contacts sized for load being connected. Wire control to boiler. See Figure below.

Connect LWCO device to the system ground. Ground Boiler in accordance with the requirements of the authority having jurisdiction or, in the absence of such requirements, with the National Electrical Code (NEC) or Canadian Electrical Code CEC.

- Locate LWCO sensing device in the supply piping, above the minimum height of boiler. See Figure page 42, Piping Diagram.
- Position control in piping above boiler to assure proper boiler protection.
- For proper operation, sensing element of the LWCO control shall be positioned in the tee to sense the main water stream. Maintain minimum 1/4" spacing from pipe walls. Element shall NOT contact the rear, or side walls of the tee. See Figure page 43.
- Install an air vent using a tee to avoid nuisance shutdowns.
- Apply small amount of pipe sealant to threaded connections.
- Arrange piping to prevent water dripping onto boiler.
- DO NOT install water shutoff valve between boiler and LWCO sensing device.

### LWCO WIRING DIAGRAM



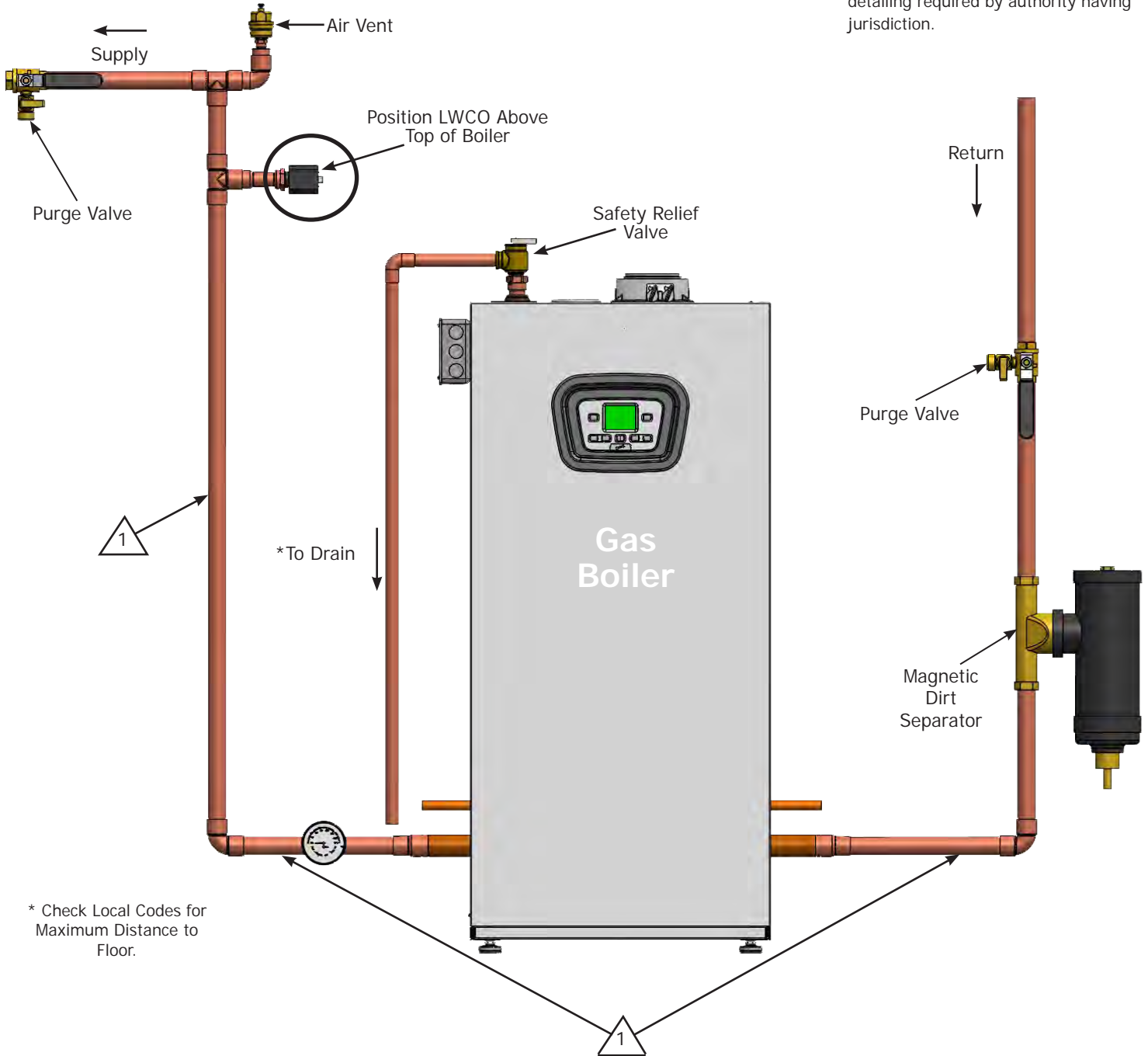



# LOW WATER CUTOFF

## PIPING DIAGRAM - LWCO LOCATION

**Note** Arrange piping to prevent water dripping onto boiler.

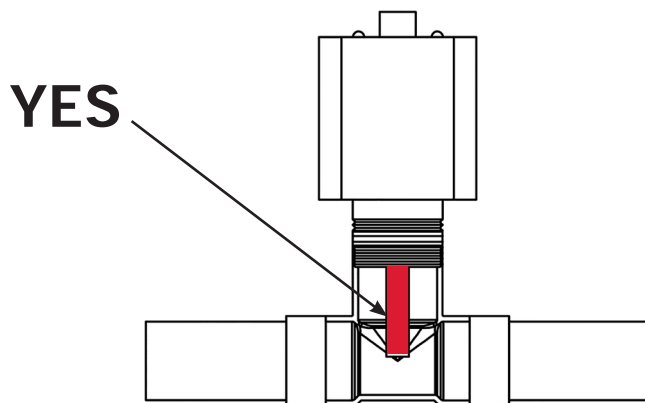
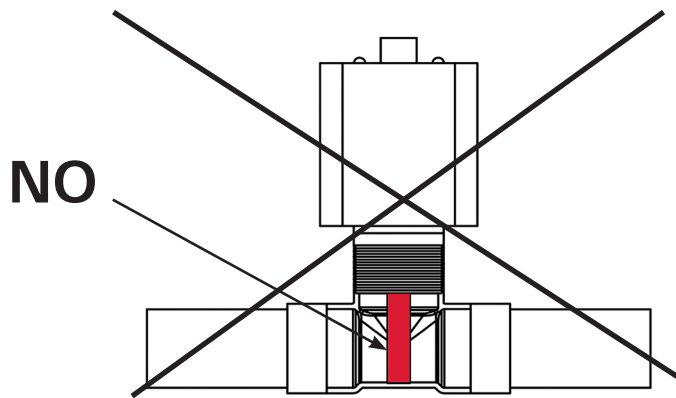
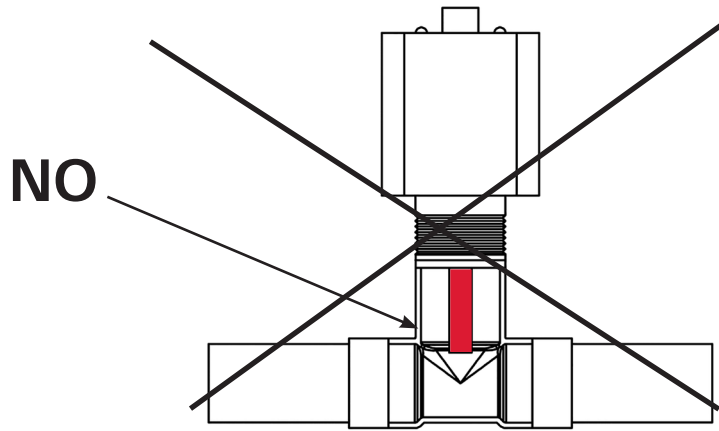
**Note** Illustrations are meant to show system piping concept only. Installer is responsible for all equipment and detailing required by authority having jurisdiction.



**Note**  DO NOT PLACE ISOLATION VALVE BEFORE TEE OR LWCO.

# LOW WATER CUTOFF

## LOW WATER CUTOFF - DETAIL



## ERROR CODE TABLE

**Note:** When instructed press and hold "RESET" for between 1-3 seconds to reset the boiler.

### Table of Error Codes

<b>E</b> 09	Gas Valve Connection Cable
<b>E</b> 10	External Probe Fault
<b>E</b> 12	Water Flow Switch Open
<b>E</b> 13	Water Flow Switch Close
<b>E</b> 15	Gas Valve Fault
<b>E</b> 18	Water Refill Enabled
<b>E</b> 19	Max Time Of Water Refill
<b>E</b> 20	Central Heating Flow NTC Fault
<b>E</b> 28	Flue NTC Fault
<b>E</b> 40	Central Heating Return NTC Fault
<b>E</b> 50	Hot Water NTC Fault (tank version)
<b>E</b> 53	Obstruction on flue pipe-combustion off
<b>E</b> 55	PCB to be set by the "Calibration Function"
<b>E</b> 71	Fan parameter Out of range in auto calibration
<b>E</b> 72	Combustion test out of range in auto calibration
<b>E</b> 77	Current Out of range
<b>E</b> 78	Minimum gas valve current
<b>E</b> 79	Maximum gas valve current
<b>E</b> 83-87	Communication error
<b>E</b> 92	Combustion test alarm during auto-setting
<b>E</b> 109	Pre-Circulation Fault
<b>E</b> 110	Safety Thermostat Operated
<b>E</b> 117	System Water Pressure To High
<b>E</b> 118	System Water Pressure To Low
<b>E</b> 125	Circulation Fault (Primary Circuit)
<b>E</b> 128	Flame Failure
<b>E</b> 129	Frequent loss of flame during ignition
<b>E</b> 130	Flue NTC Operated
<b>E</b> 133	Interruption of Gas Supply or Flame Failure
<b>E</b> 134	Elapsed time Gas valve open without gas
<b>E</b> 135	Interruption of gas supply (internal error)
<b>E</b> 160	Fan or Fan Wiring Fault
<b>E</b> 321	Domestic Hot Water NTC sensor fault
<b>E</b> 384	False flame
<b>E</b> 385	Under voltage

### Initial Fault Finding Checks

- 1 Check gas, water and electrical supplies are available at the boiler.
- 2 Electrical supply = 120V ~60 HZ
- 3 The preferred minimum gas pressure is 3.5" wc for Natural gas and 10" for LPG
- 4 Perform electrical system checks, i.e. Ground Continuity, Resistance to Ground, Short Circuit and Polarity with a suitable meter.

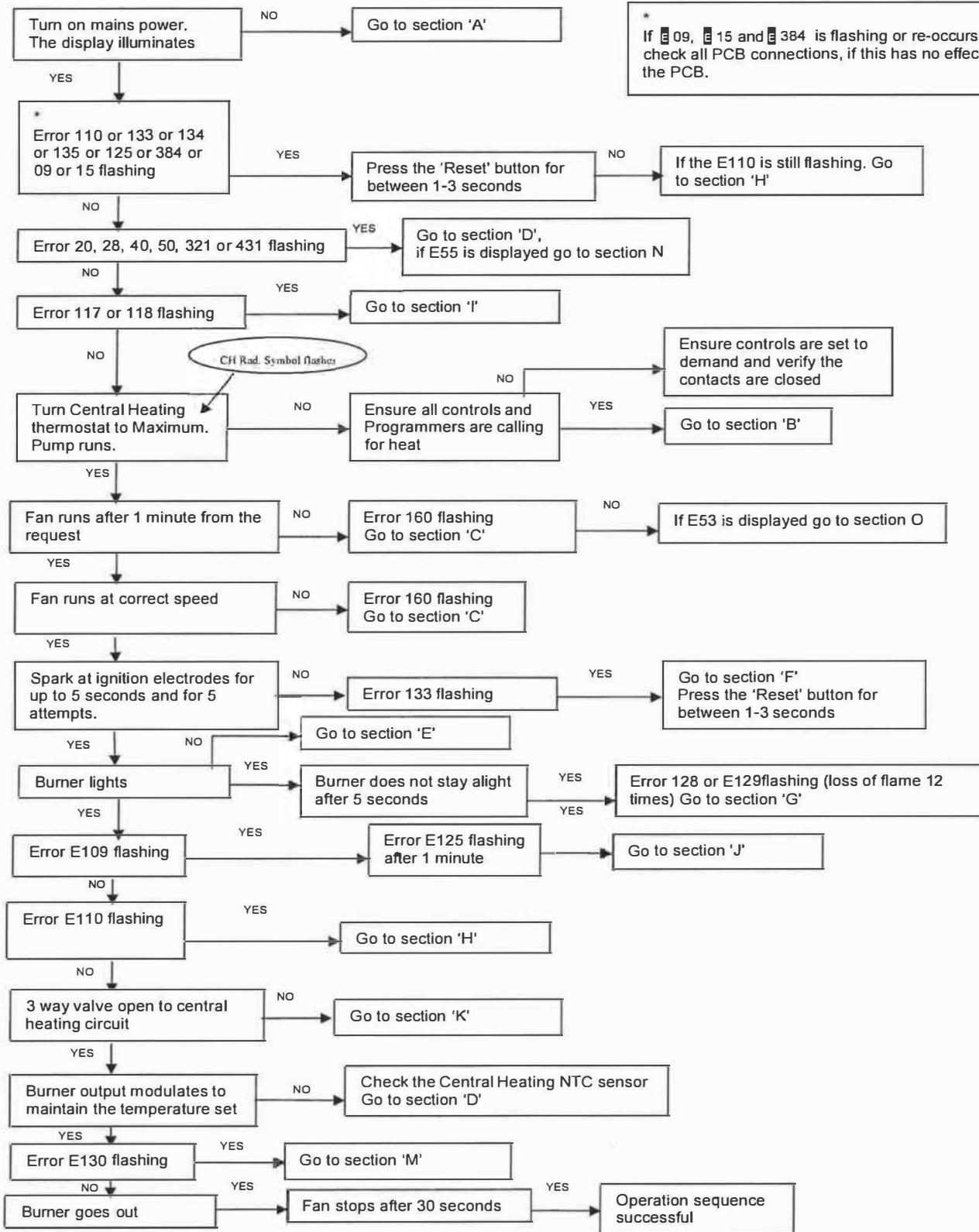
**NOTE: These checks must be repeated after any servicing or fault finding.**

- 5 Ensure all external controls are calling for heat and check all external and internal fuses. Before any servicing or replacement of parts, ensure the gas and electrical supplies are isolated.

- 1 If a fault occurs on the boiler an error code may show on the fascia display:
  - E** 20, **E** 28, **E** 40, **E** 50, **E** 160, **E** 321, and **E** 431 - Indicate possible faulty components.
  - E** 53 - Indicates possible obstruction in the flue duct.
  - E** 55 - Indicates the PCB is not setting/calibrated.
  - E** 71, **E** 72, **E** 78 and **E** 92 - Indicates possible wrong calibration, a new calibration is needed.
  - E** 92 - Indicates possible flue recirculation in the flue duct.
  - E** 83.....87 - Shows possible error of communication with thermostat. (Go to section P, page 47)
  - E** 110 - Shows overheat of primary.
  - E** 117 - is displayed when the primary water pressure is more than 43 psi.
  - E** 118 - is displayed when the primary water pressure is less than 7.25 psi.
  - E** 125 - is displayed in either of two (2) situations:
    - a) If within a time between 15...30 seconds of the burner lighting the boiler temperature has not changed by 2°F.
    - b) If within 10 minutes of the burner lighting the boiler temperature twice exceeds the selected temperature by 80°F.
 In these instances poor primary circulation is indicated.
  - E** 128 - is displayed if there has been a flame failure during normal burner operation.
  - E** 133, **E** 134, **E** 135 - Indicate the gas supply has been interrupted, ignition has failed or flame has not been detected.
- 2 Pressing the 'RESET' button for 1-3 seconds when: **E** 110, **E** 125, **E** 133, **E** 134, **E** 135, **E** 09, **E** 15, **E** 128 and **E** 384 - are displayed it is possible to relight the boiler.
- 3 If this does not have an effect, or error codes are displayed regularly further investigation is required.

# TROUBLESHOOTING CHART

## Central Heating

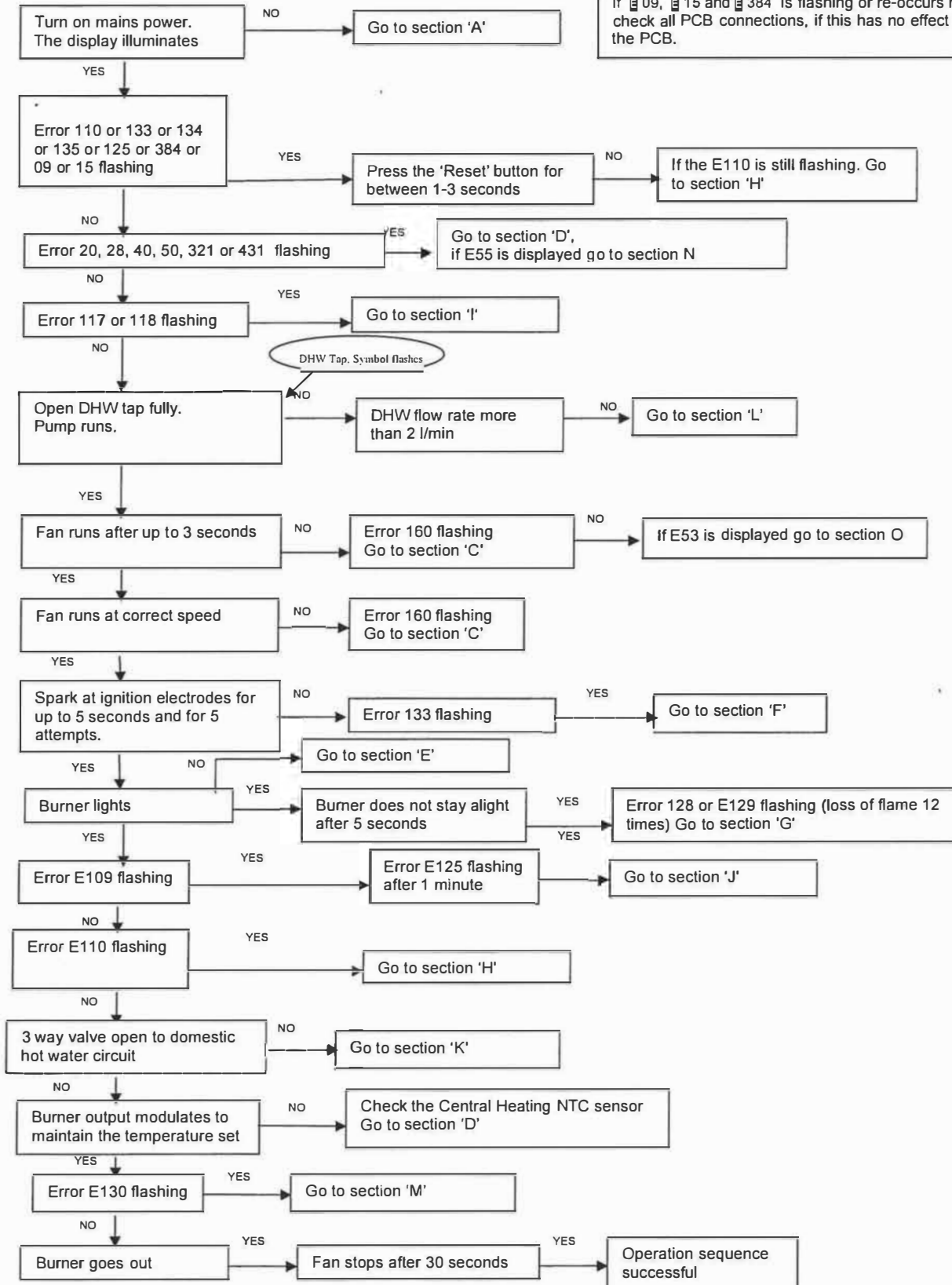


\* If **09**, **15** and **384** is flashing or re-occurs regularly check all PCB connections, if this has no effect replace the PCB.

# TROUBLESHOOTING CHART

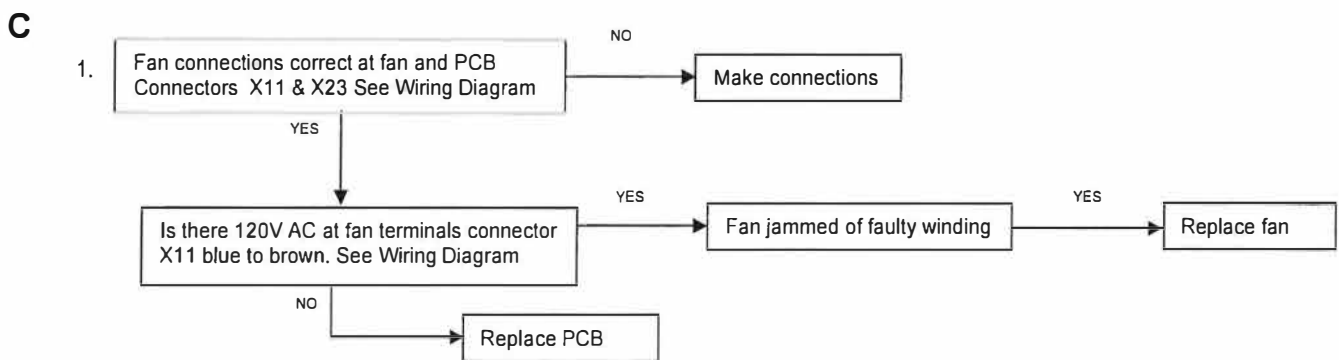
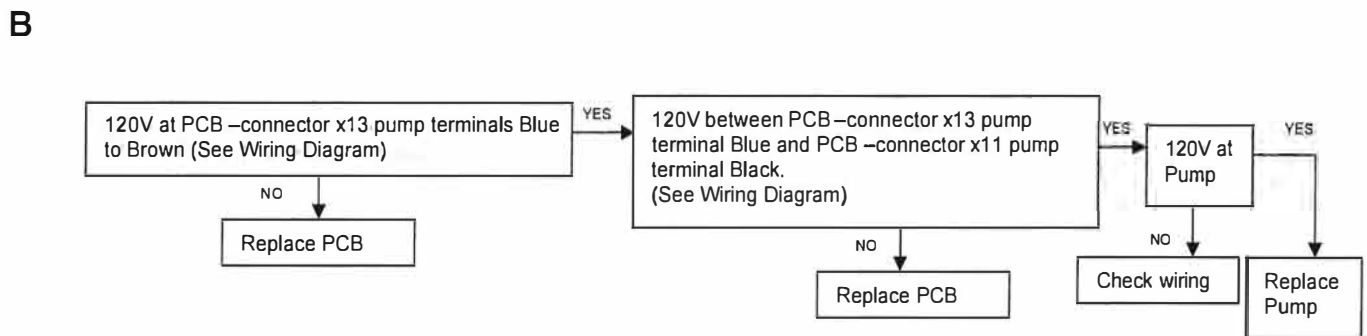
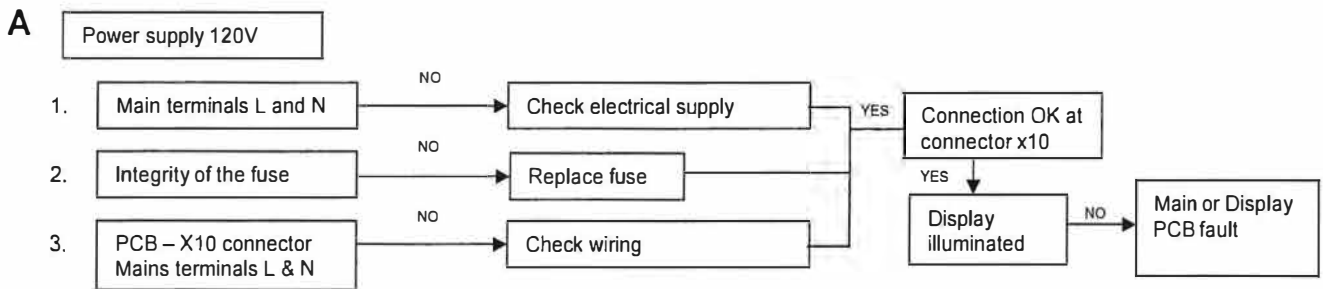
## Domestic hot water

\* If 09, 15 and 384 is flashing or re-occurs regularly check all PCB connections, if this has no effect replace the PCB.



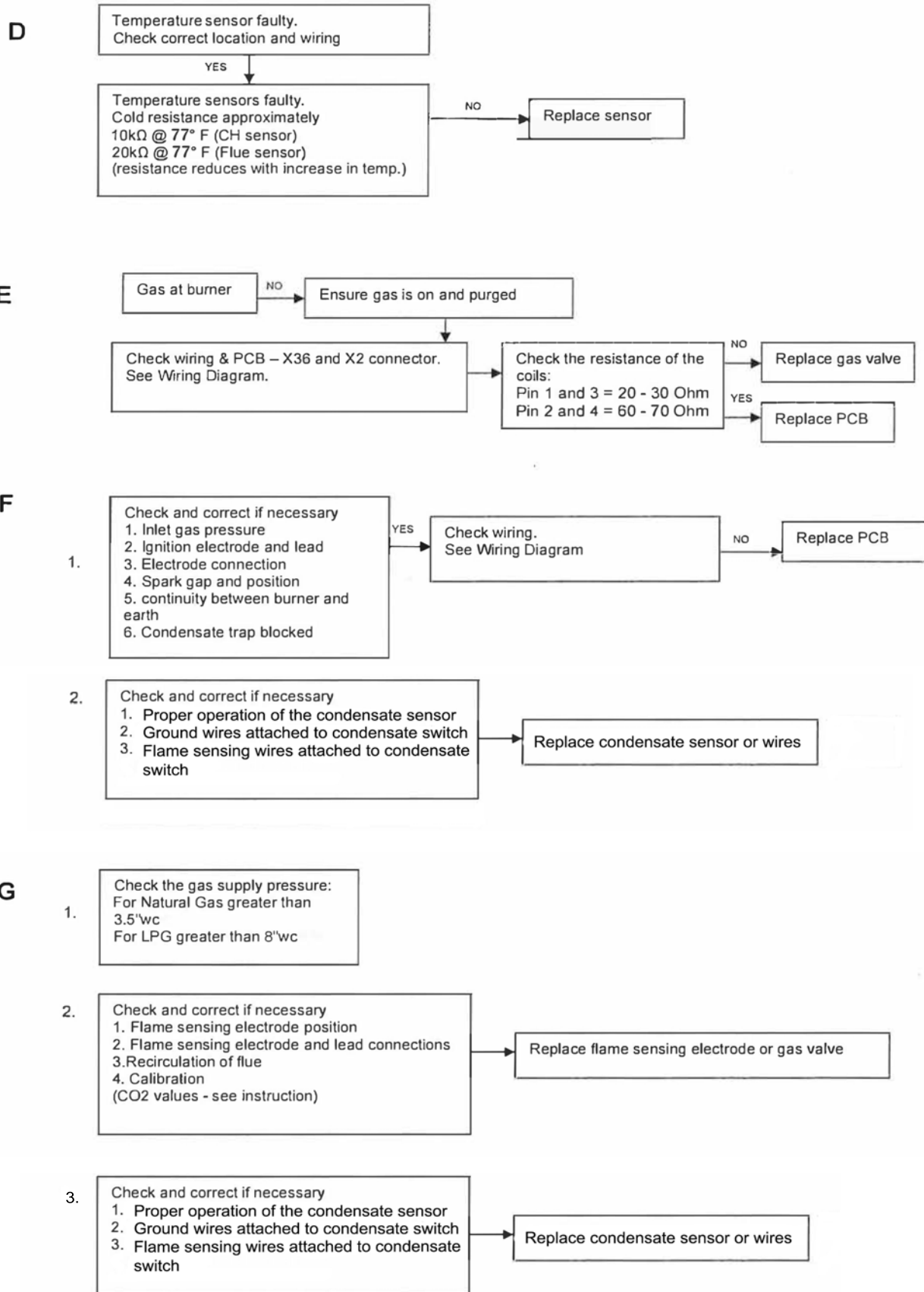
# FAULT SOLUTION SECTIONS

## Fault Finding Solutions Sections



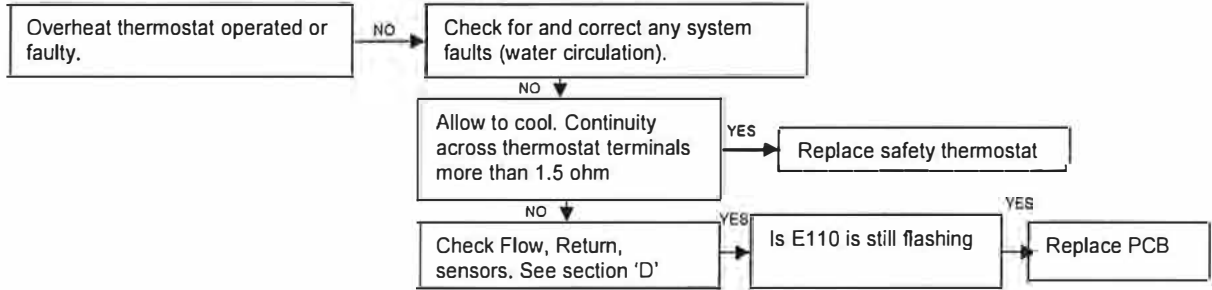


## FAULT SOLUTION SECTIONS

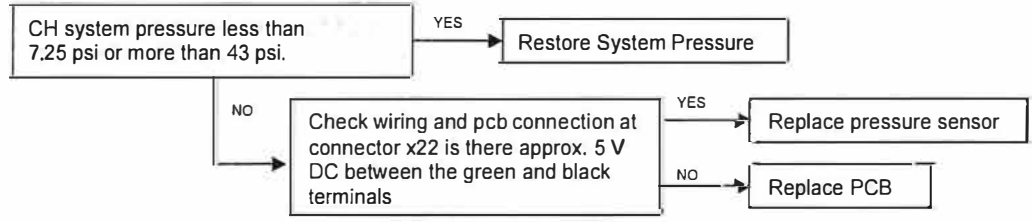


# FAULT SOLUTION SECTIONS

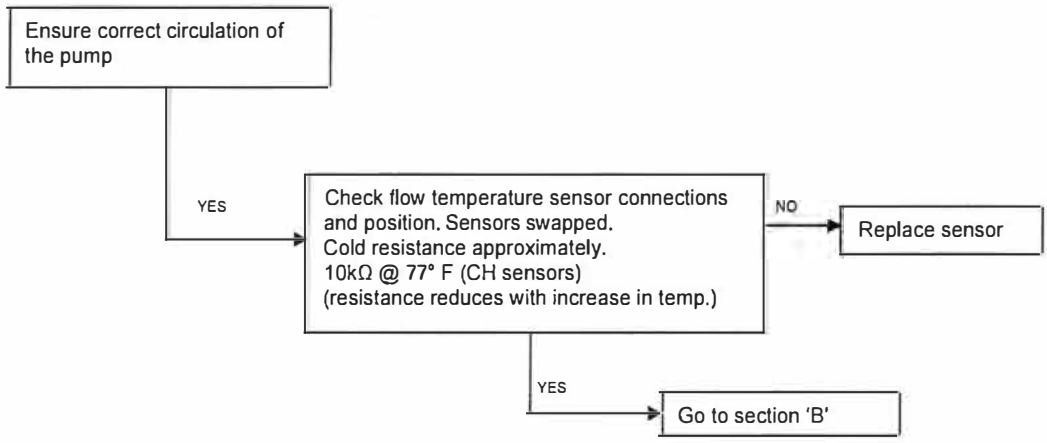
**H**



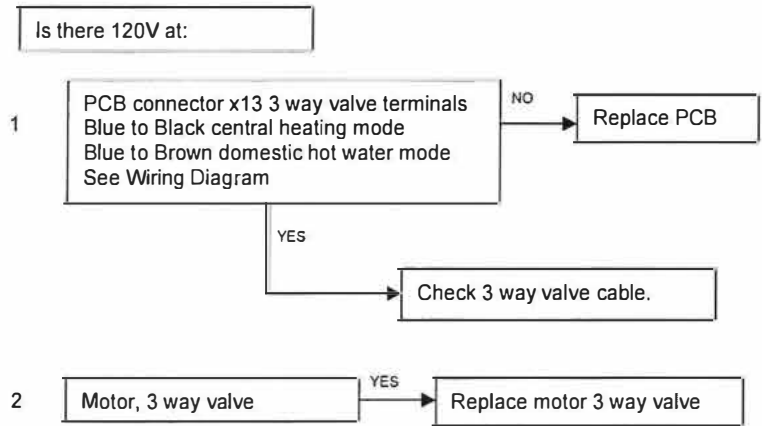
**I**



**J**

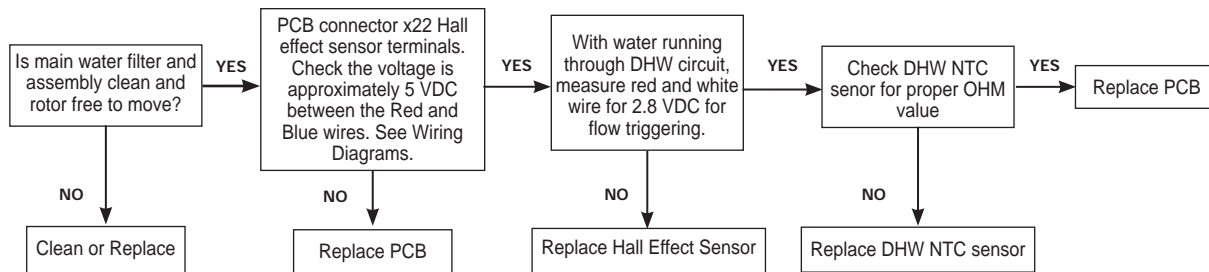


**K**

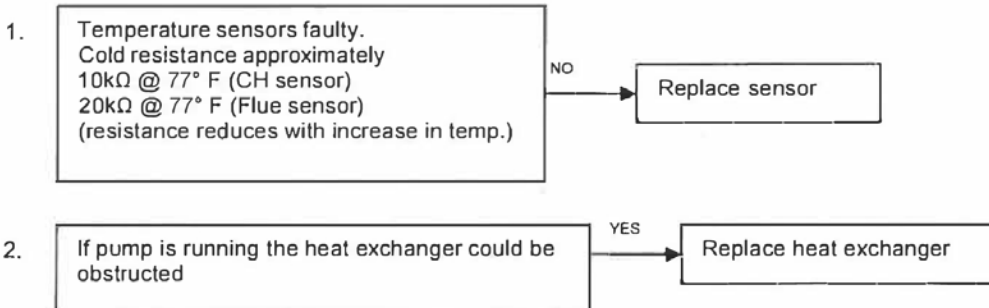


## FAULT SOLUTION SECTIONS

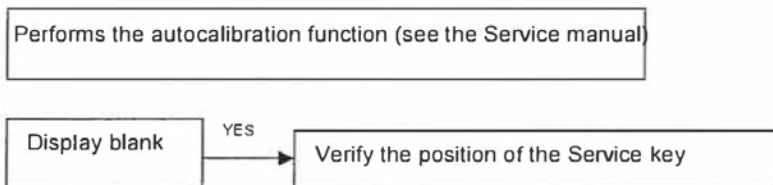
**L**



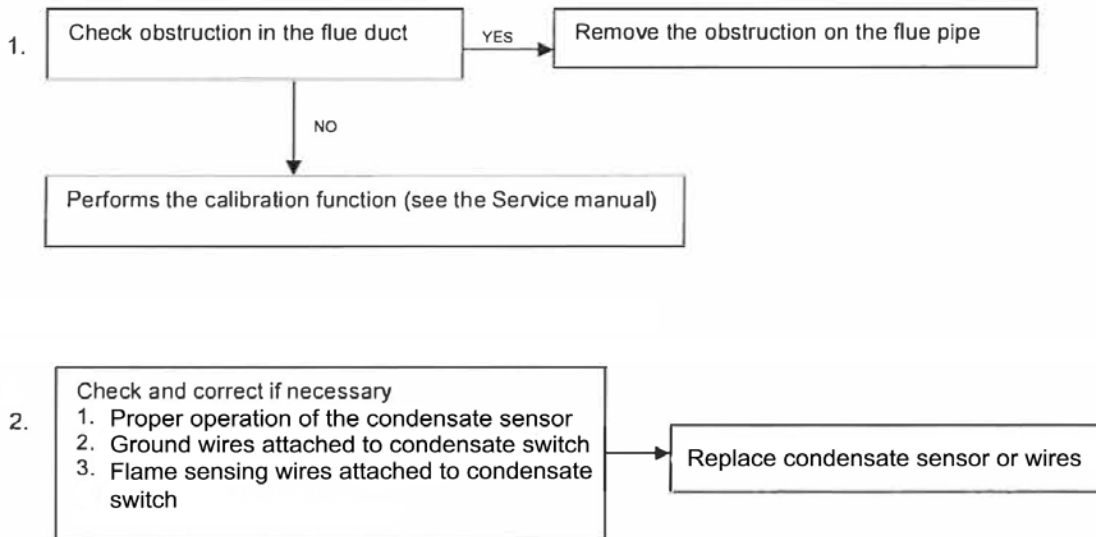
**M**



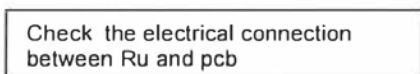
**N**



**O**



**P**





**IMPORTANT INFORMATION**  
*READ THIS LEAFLET BEFORE COMMISSIONING THE BOILER*

**IMPORTANT:**

**Upon startup of this new boiler please call  
ECR International, Inc. Technical Support  
for installation assistance and registration.**

**Technical Support and Product Registration  
Monday - Friday 8AM to 6PM Eastern time.  
1.800.253.7900**

Described below is the procedure to activate the Commissioning Function which includes De-Aeration Function/Gas Type Check when power is first supplied to the boiler and the actions required when on a Gas E (LPG) supply.

Commissioning Function is as follows:

- When power is supplied to the boiler for the first time **000** will be displayed. If **⏻** is shown, press **⏻R**, for at least 2 seconds **000** will now be displayed.
- Press **iP** & **||||+** together and hold for at least 6 seconds. The “De-Aeration” Function will be activated & “On” showing.
- The boiler pump will run for up to 10 minutes. For 3-way valve models the valve will switch between heating & hot water. This will purge air from the system. The display will show **3 12**.

### Gas Type Check

- Once de-aeration is complete on first fire-up the boiler will light and operates for 6 or 7 minutes to automatically check the gas type Gas A (Natural Gas “NG”) or Gas E (Liquefied Petroleum Gas “LPG”). The boiler software check the combustion value against the set value. **000** will be displayed alternating the % value of ignition power and the temperature value °F(°C).
- On a Gas A (Natural Gas) supply the display shows **n G** for at least 10 seconds and the boiler is ready for the normal operation. If the display shows **LPG**, press **⏻R** & **iP** together and hold for at least 4 seconds to exit the function without saving.
- On a Gas E (LPG) supply the display show **LPG**, press **iP** for at least 6 seconds to confirm that this is the intended gas type for the installation.  
If the display shows **n G**, press **⏻R** & **iP** together and hold for at least 4 seconds to exit the function without saving then modify **P02=01** as described in the Manual Instructions for the Installer section “PARAMETERS SETTING”.
- While the gas type is being identified, the boiler may be noisy.

IF THE BOILER IS TO BE OPERATED ON GAS E (LP) REPLACE THE EXISTING LABEL WITH THE GAS E LABEL SUPPLIED WITH THIS INSTRUCTION. ASSURE FACTORY SUPPLIED CONVERSION LABEL IS APPLIED TO PRODUCT IF CONVERTING TO LP.

### IMPORTANT: Gas type Check

*Ensure the maximum heat exchange to the system in Heating or DHW mode (DHW request) in order to avoid the boiler shutoff for overheating.*

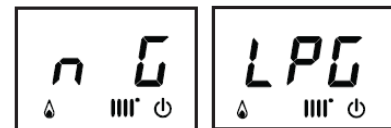
#### FUNCTION INTERRUPT

If either De-aeration or Gas Check is interrupted by electrical power failure is necessary to reactivate the function by pressing **iP** & **||||+** together for at least 6 seconds. During De-aeration, if the display shows E118 (water low pressure), open the water filling tap and repressuring the system to the correct pressure value. During Gas Type Check, if the display shows E133 (Ignition Failure), press **⏻R** button to Reset then press together **iP** & **||||+** for at least 6 seconds to restart the function. During Gas Type Check, if the boiler switch off for overheating failure is necessary to reactivate the function by pressing **iP** & **||||+** together for at least 6 seconds.

**IMPORTANT:** The combustion for this appliance has been checked, adjusted and pre-set at the factory for operation on the gas type specified on the appliance data plate.

**During the Gas Type Check Function the combustion ratio will increase for a short time while the gas type is established.**

*The display shows the Gas Type Check*



CG\_2120

# INFORMATIONS IMPORTANTES



LIRE CET IMPRIMÉ AVANT DE METTRE LA CHAUDIÈRE EN MARCHÉ

**IMPORTANT :** Lors du démarrage de cette nouvelle chaudière veuillez appeler recueil International, Inc. de support technique pour l'assistance à l'installation et l'enregistrement.



Support technique et enregistrement du produit  
lundi - vendredi 8h00 à 18h00 heure de l'Est.  
1.800.253.7900

Ci-après la procédure d'activation de la Fonction Désaération/Identification Type de Gaz lorsque la chaudière est raccordée pour la première fois à la réseau électrique et les actions à mettre en œuvre en cas d'alimentation avec du gaz propane.

## Fonction Désaération

- Lorsque la chaudière est raccordée pour la première fois à la réseau électrique l'afficheur indique **000**. Si  est affiché, appuyer pendant au moins 2 secondes sur la touche  ; l'afficheur montrera alors le symbole **000**.
- Appuyer simultanément sur les touches **iP** et **|||+** pendant au moins 6 secondes. La fonction « Désaération » est alors activée et l'indication « On » apparaît sur l'afficheur.
- La pompe de la chaudière se met en marche pendant environ 10 minutes. Pour les modèles à production instantanée d'eau chaude, la vanne à 3 voies effectuera la commutation entre les fonctions chauffage et eau chaude sanitaire, ainsi que la purge de l'air présent dans l'installation. L'afficheur indique **3 12**.

## Identification du type de gaz

- Quand la désaération est terminée la chaudière se mise en marche pendant environ 6-7 minutes pour vérifier automatiquement le type de gaz utilisé **nG** Gaz A (gaz naturel) ou Gaz E **LPG** (gaz liquide). Le logiciel de la chaudière compare la valeur de combustion avec la valeur prédéfinie. L'afficheur montre **000**, en alternance avec la valeur en % de la puissance d'allumage et la valeur de la température °F (°C) de départ du chauffage.
- Si la chaudière est alimentée au Gaz A (gaz naturel), l'afficheur indiquera **n G** pendant environ 10 secondes. La chaudière est donc prête à fonctionner normalement. Si l'afficheur montre **LPG** appuyer simultanément sur les touches  et **iP** pendant au moins 4 secondes pour quitter sans modifier le réglage d'usine.
- Si la chaudière est alimentée au Gaz E **LPG** (gaz liquide), l'afficheur montrera **LPG**. Appuyer pendant au moins 6 secondes sur la touche **iP** pour valider le type de gaz effectivement utilisé. Si l'afficheur indique **n G** car le gaz d'alimentation n'est pas reconnu, appuyer simultanément sur les touches  et **iP** pendant au moins 4 secondes pour quitter la fonction, puis modifier le paramètre **P02=01** comme cela est décrit dans le manuel d'utilisation pour l'installateur dans « CONFIGURATION PARAMÈTRES » de la chaudière.
- Pendant le phase d'identification du type de gaz la chaudière peut être bruyante.

Si la chaudière est exploitée à GAS E (LP) remplacer l'étiquette existante avec le gaz E ÉTIQUETTE FOURNIE AVEC CETTE NOTICE. Assurer la conversion de la configuration usine étiquette est appliquée au produit SI LA CONVERSION DE LP.


## IMPORTANT : Identification du type de gaz

**Garantir l'échange thermique maximum à l'installation de chauffage ou de production d'ECS afin d'éviter que la chaudière ne s'éteigne suite à un problème de surchauffe.**

### INTERRUPTION DE LA FONCTION

Si la fonction de désaération ou d'identification du gaz est interrompue par une coupure de l'alimentation électrique, une fois que le courant est rétabli, réactiver la fonction en appuyant simultanément sur les touches **iP** et **|||+** pendant au moins 6 secondes.

Si pendant la Fonction de Désaération l'afficheur signale l'erreur E118 (basse pression du circuit hydraulique), manœuvrer le robinet de remplissage de l'appareil pour rétablir la pression correcte.

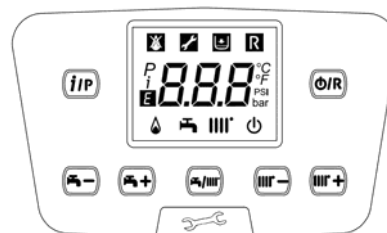
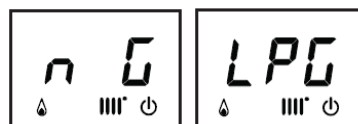
Si la fonction d'identification du gaz est interrompue suite à une erreur (par exemple, E133 absence de gaz), appuyer sur la touche  pour réinitialiser, puis appuyer simultanément sur les touches **iP** et **|||+** (pendant au moins 6 secondes) pour réactiver la fonction.

Si la fonction d'identification du gaz est interrompue suite à un problème de surchauffe, réactiver la fonction en appuyant simultanément sur les touches **iP** et **|||+** pendant au moins 6 secondes.

**REMARQUE :** la combustion de cet appareil a été contrôlée, étalonnée et prédéfinie en usine pour fonctionner avec du gaz NATUREL.

**Pendant la Fonction de Contrôle du Type de Gaz, le rapport de combustion augmentera pour une courte durée afin de permettre l'identification du type de gaz.**

L'afficheur montre l'identification du type de gaz.



CG\_2120



## Required Inspection Schedule To Be Completed By Qualified Service Technician

Inspection Items			Date Completed			
			Year 1	Year 2	Year 3	Year *4
Piping	Near boiler piping	Check boiler and system piping for any sign of leakage, verify pipes are properly supported.				
	Vent	Check condition of all vent pipes and joints. Verify vent piping terminations are free of obstructions and blockages.				
	Safety Relief Valve	Follow safety relief valve manufacturer's instructions for maintenance and repair. Verify discharge pipe properly installed per IOM.				
System	Visual	Do full visual inspection of ALL system components.				
	Functional	Test all functions of the system (heat and safety)				
	Temperatures	Verify safe settings on boiler or anti-scald valve.				
Verify programmed temperature settings.						
Electrical	Connections	Check wire connection. Verify connections are tight.				
	Smoke and Co detector	Verify devices are installed and working properly. Change batteries if necessary.				
	Circuit Breakers	Check that circuit breaker is clearly labeled and operates correctly.				
Chamber/ Burner	Combustion Chamber	Check burner and combustion chamber. Clean following directions in maintenance section of IOM. Replace gaskets whenever checking combustion chamber.				
	Spark Electrode	Clean. Set gap according to IOM directions. Clean electrode with plumbers cloth to remove oxides.				
	Flame Sensor	Clean sensor.				
Condensate	Neutralizer	Check condensate neutralizer - replace if necessary.				
	Condensate pipe/trap	Disconnect condensate pipe. Clean out any dirt or accumulation. Fill with water level of outlet and reinstall. NOTE: verify flow of condensate, make sure hose is properly connected during final inspection.				
Gas	Pressure	Measure incoming gas pressure per IOM.				
	Pressure drop	Measure drop in pressure on light off verify with IOM.				
	Leaks	Check gas piping. Test for leaks and signs of aging. Make sure all pipes are properly supported.				
Combustion	CO/CO <sub>2</sub> Levels	Check CO and CO <sub>2</sub> level in exhaust. See Start-up Procedures for ranges. Record at high and low fire.				
Safety	All Sensors	Check continuity of all sensors. Replace if corroded. Verify all connections through ohms reading.				
Final Inspection	Check List	Verify you have completed entire check list.				
	Homeowner	Review findings and service with Homeowner.				

\* Continue inspections beyond 4th year. Maintenance should continue annually for the life of the boiler to ensure safe worry free operation.