

Model CHB-100 CHB-130

WALL MOUNTED
GAS BOILER

INSTALLATION, OPERATION & MAINTENANCE MANUAL



cod. 3541F240



Manufactured for:
ECR International, Inc.
2201 Dwyer Avenue, Utica NY 13501
web site: www.ecrinternational.com

P/N# 240010633, Rev. B [07/17/2014]

DIMENSIONS

Figure 1 - Overall Dimensions

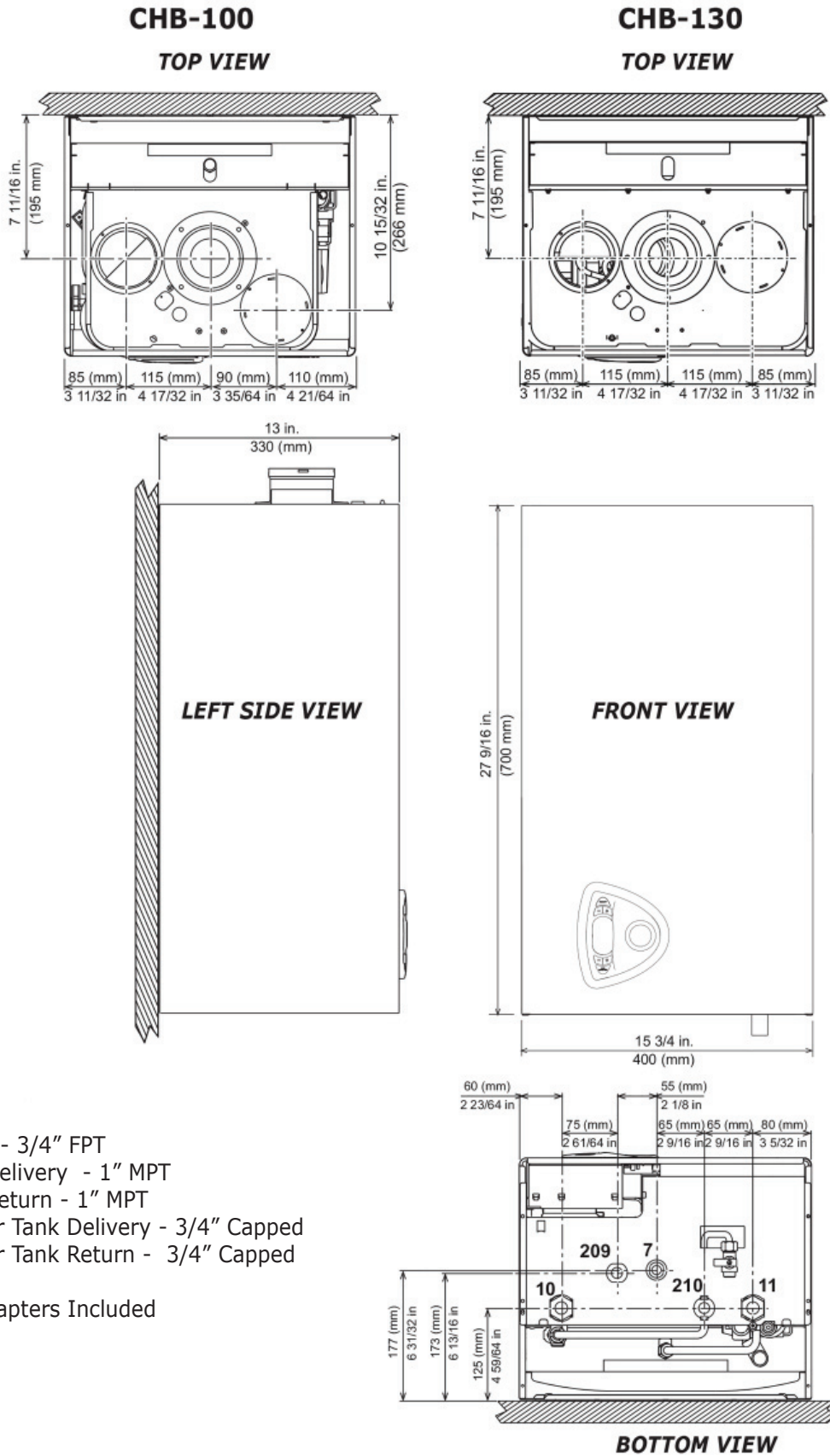

- 7** = Gas Inlet - 3/4" FPT
- 10** = System Delivery - 1" MPT
- 11** = System Return - 1" MPT
- ***209** = Hot Water Tank Delivery - 3/4" Capped
- ***210** = Hot Water Tank Return - 3/4" Capped

* BSPT To NPT Adapters Included

TABLE OF CONTENTS

1 - Introduction.....	4
2 - Important Safety Information.....	5
3 - General view and main components	6
4 - Locating Boiler	9
5 - Hydronic Piping	11
6 - Combustion Air And Vent Piping - Category I (Chimney Vent)	15
6 - Combustion Air And Vent Piping of direct vent and Category III	17
7 - Gas Supply Piping.....	22
8 - Electrical Connections	23
9 - Start Up Procedure	24
10 - Operating Instructions.....	26
11 - General Maintenance And Cleaning.....	32
12 - Ratings And Capacities	33
13 - Trouble Shooting.....	36
Wiring diagram	37
Repair Parts List - CHB-100.....	38
Repair Parts List - CHB-130.....	44

1 - INTRODUCTION

1.1 Designated Use

- Hot water heating boiler.
- Indoor installation.
- Closet or alcove installation.
- Category I or III Venting.
- For use with natural gas or liquefied petroleum gases (LP/propane). LP kit available.
- Indirect heating is acceptable.
- Boiler is arranged for connection to an external storage tank for hot water production (optional). All functions relevant to domestic hot water production are only active with the optional water tank sensor connected.

1.2 The unit **MUST NOT**:

- Directly heat potable water.
- Heat water with non-hydronic heating system chemicals present (example, swimming pool water).
- Exceed 185°F (85°C) system design temperature.
- Exceed 43.5 PSIG

1.3 Operational Features

- Modulating: 3-1 turn down.
- Integral Dual Limit.

Information and specifications outlined in this manual in effect at the time of printing of this manual. ECR International, Inc. reserves the right to discontinue, change specifications or system design at any time without notice and without incurring any obligation, whatsoever.

2 - IMPORTANT SAFETY INFORMATION

2.1 General

Boiler installation shall be completed by qualified agency. See glossary for additional information.

WARNING

Fire, explosion, asphyxiation and electrical shock hazard. Improper installation could result in death or serious injury. Read this manual and understand all requirements before beginning installation.

2.2 Become familiar with symbols identifying potential hazards.



This is the safety alert symbol. Symbol alerts you to potential personal injury hazards. Obey all safety messages following this symbol to avoid possible injury or death.

DANGER

Indicates a hazardous situation which, if not avoided, WILL result in death or serious injury.

WARNING

Indicates a hazardous situation which, if not avoided, could result in death or serious injury.

CAUTION

Indicates a hazardous situation which, if not avoided, could result in minor or moderate injury.

NOTICE

Used to address practices not related to personal injury.

2.3 Installation shall conform to requirements of authority having jurisdiction or in absence of such requirements:

- United States
 - National Fuel Gas Code, ANSI Z223.1/NFPA 54.
 - National Electrical Code, NFPA 70.
- Canada
 - Natural Gas and Propane Installation Code, CAN/CSA B149.1.
 - Canadian Electrical Code, Part I, Safety Standard for Electrical Installations, CSA C22.1

2.4 Requirements for Commonwealth of Massachusetts:

Boiler installation must conform to Commonwealth of Massachusetts code 248 CMR which includes but is not limited to:

- Installation by licensed plumber or gas fitter.

2.5

Where required by the authority having jurisdiction, the installation must conform to the Standard for *Controls and Safety Devices for Automatically Fired Boilers*, ANSI/ASME CSD1.

3 - GENERAL VIEW AND MAIN COMPONENTS

Figure 2 Component Listing

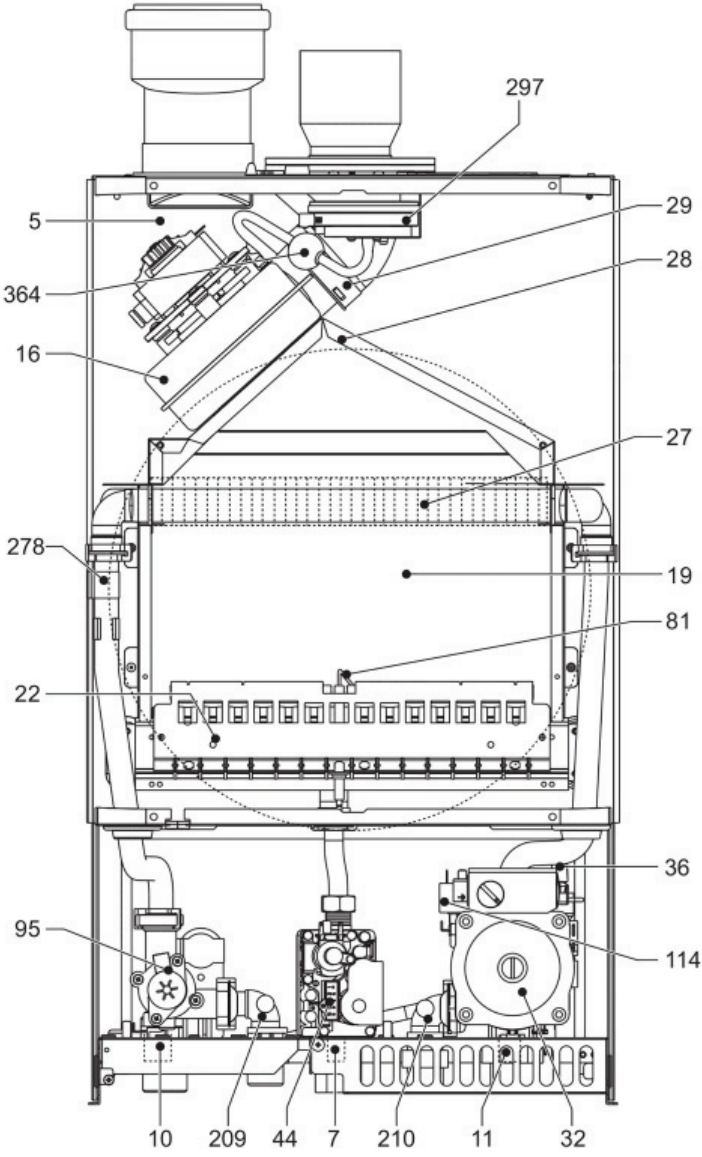
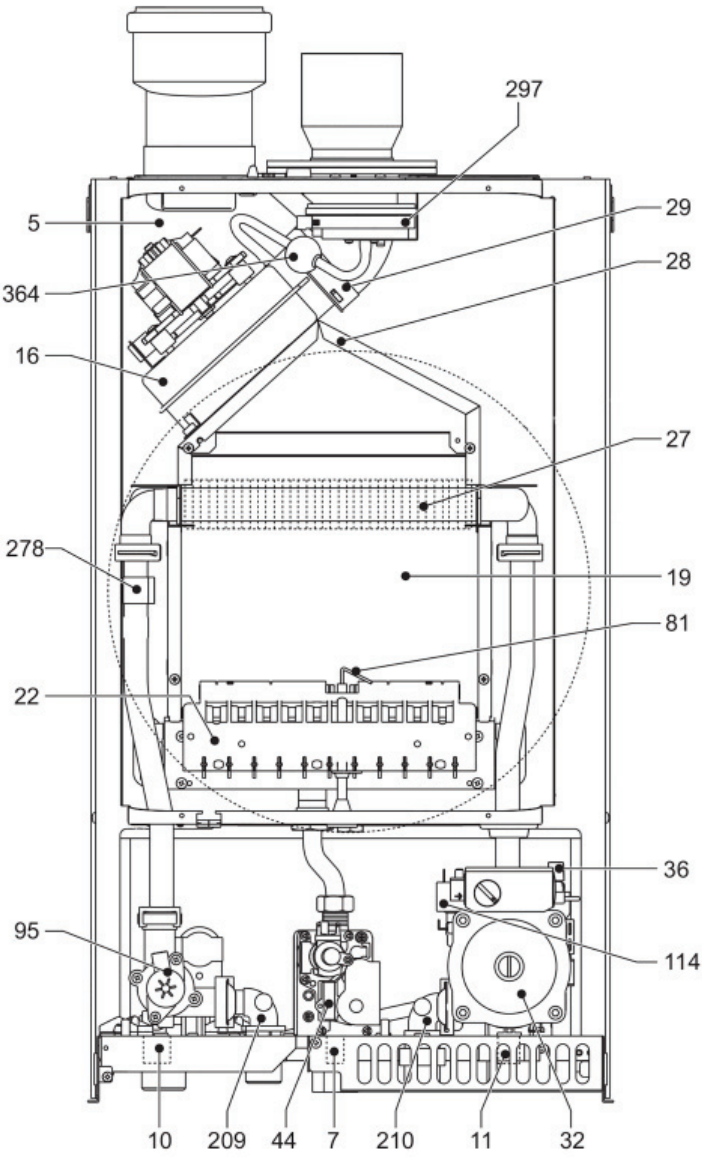

3 - GENERAL VIEW AND MAIN COMPONENTS

Item Number	Description
5	Sealed Chamber
7	Gas Inlet
10	Supply System
11	System Return
16	Modulating Fan
19	Combustion Chamber
22	Burner
27	Copper Heat Exchanger
28	Exhaust Manifold
29	Exhaust Outlet Manifold
32	Heating circulating pump
36	Automatic Air Vent
44	Gas Valve
81	Ignition and Detection Electrode
95	3 Way Diverter Valve
114	Water Pressure Switch
209	Hot Water Tank Delivery
210	Hot Water Tank Return
278	Double Sensor - High Limit NTC
297	Air Pressure Switch
364	Condensation Coupling

		LBS	Kg
Unit Weight	CHB 100	61	27.5
	CHB 130	65	29.5
Shipping Weight	CHB 100	65	29.5
	CHB 130	69	31.5

3 - GENERAL VIEW AND MAIN COMPONENTS

⚠ WARNING

Fire, explosion, asphyxiation and electrical shock hazard. Disconnect electrical power supply and turn off gas at shutoff valve before attempting to remove boiler jacket. Failure to follow these instructions could result in death or serious injury.

Remove Boiler Jacket

1. Unscrew screws (A).
2. Pivot jacket upwards. See figure 3.
3. Raise Jacket up and off boiler. See figure 4.

Figure 3 - Jacket Removal - Screw Locations

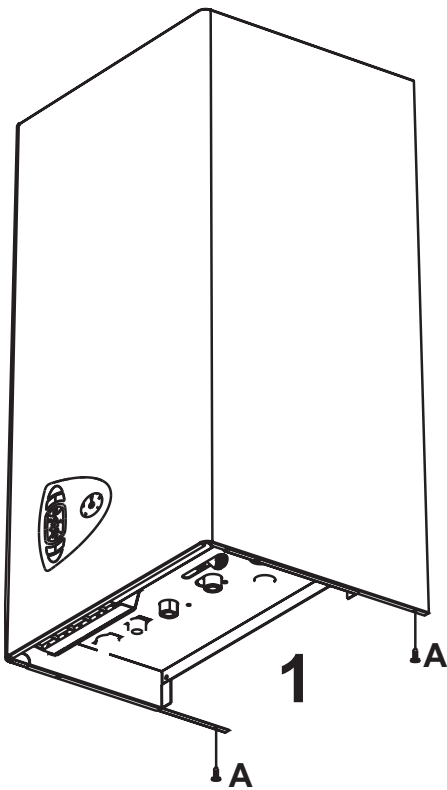
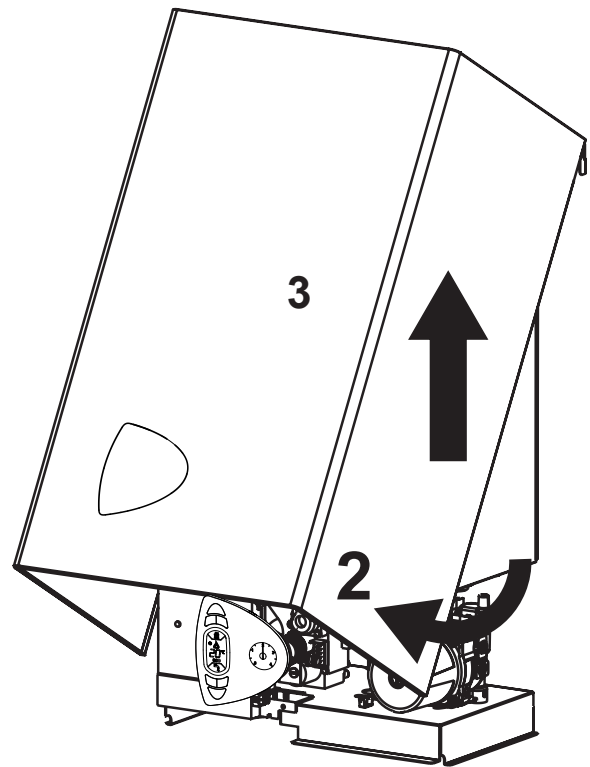

Figure 4 - Pivot Jacket and Raise to Remove



4 - LOCATING BOILER

4.1 Boiler Location Considerations

- Ambient room temperature always above 32°F (0°C) to prevent freezing.
- Approved for installation in closets.
- Protect gas ignition system components from water (dripping, spraying, rain, etc.) during operation and service (circulator replacement, control replacement, etc.).
- Wall mount only.
- Access to outdoors to meet minimum and maximum pipe lengths for combustion air and vent piping. See section 6.
- Drainage of water (or water - antifreeze solution) during boiler service or from safety relief valve discharge. See section 5.
- Access to system water piping, gas supply, and electrical service. See sections 5, 7 and 8.
- Clearances to combustible materials and service clearances. See Table 1 and figure 5.
- The boiler must not be installed on carpeting.

Figure 5 - Boiler Clearances

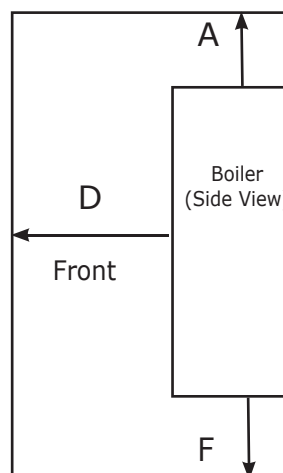
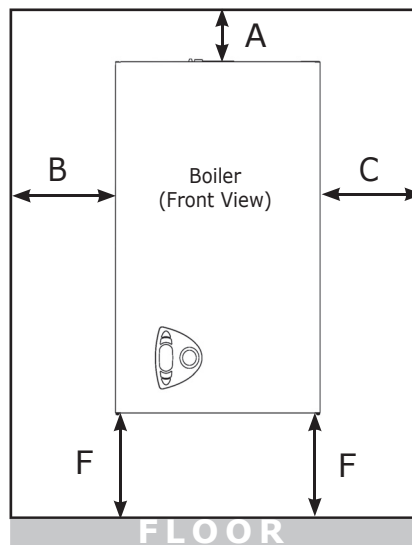

TABLE 1: BOILER CLEARANCES		
Dimension	Combustible Materials ⁽¹⁾	Service⁽¹⁾⁽²⁾
Top (A)	16" (41cm)	16" (41cm)
Left Side (B)	0" (0 cm)	1" (3 cm)
Right Side (C)	0" (0 cm)	1" (3 cm)
Front (D)	0" (0 cm)	1" 3 cm)
Back (E)	0" (0 cm)	0" (0 cm)
Bottom (F)	0" (0 cm)	12" (30 cm)
Combustion Air/piping	0" (0 cm)	3/8" (1 cm)
Vent piping	6" (15 cm)	6" (15 cm)

⁽¹⁾ Required distances measured from boiler jacket.
⁽²⁾ Service, proper operation clearance recommendation.

4 - LOCATING BOILER

4.2 Pre-pipe supply and return water connections with factory fittings before wall mounting.

4.3 Wall Mounting

Mount boiler on wall using wall mounting bracket included with unit.

- Structure must be capable of supporting boiler weight plus 60 lbs (28 kg). See page 7.
- Wall mount bracket has 2 slots, spaced at 9¼" (23.5cm) on center.
- Attach wall mount bracket level on wall.
- Boiler must engage with wall mount bracket. See figure 6.

Figure 6 - Wall Mounting Bracket

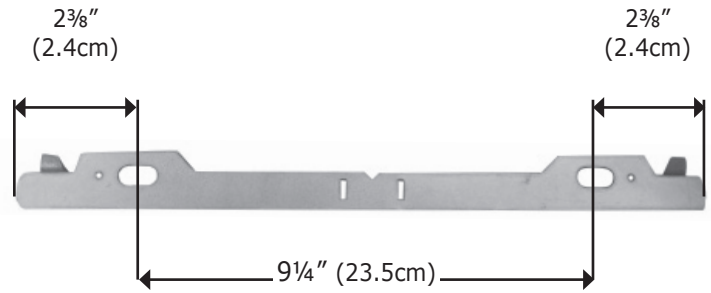

CAUTION

Boiler weight exceeds 75 pounds (34 kg). Do not lift boiler onto wall without assistance.

NOTICE

Lift boiler using chassis. Using front jacket, vent piping, water or gas fittings to lift boiler may cause damage to the boiler.

5 - HYDRONIC PIPING

5.1 General

- Install piping in accordance with authority having jurisdiction.

NOTICE

Use two (2) wrenches when tightening and fitting pipe to boiler's threaded fittings. Boiler's internal piping can be damaged if subjected to excessive torque.

- Support system piping and safety relief valve discharge piping. Boiler's internal piping and wall mount bracket can be damaged if subjected to excessive weight.
- Size central heating pump (and domestic hot water pump, if used) for system requirements only. Internal heat exchanger pump compensates for pressure drop through boiler internal piping and heat exchanger.
- Thoroughly clean and flush system before connecting to boiler.
- If oil is present in system water, use approved detergent to wash system.
- Flush system to remove any solid objects such as metal chips, fibers, or Teflon tape, etc.

5.2 Water System Characteristics

- Water in the heating system must have protection of metallic materials against corrosion.
- Filling water and subsequent replenishing, must be clear, with hardness under 150 ppm CaCO₃,
 - A. treated with approved conditioning chemicals to ensure prevention of corrosion and attack on metals and plastics, that gases do not form,
 - B. and bacterial or microbial masses do not proliferate in low temperature systems.
- Hardness exceeding 150 ppm CaCO₃, appropriate water softening treatment and/or use of suitable anti-fouling agents must be provided.

Water contained in the system must be checked at least yearly and have:

- A. pH above 7 and under 8.5 (under 8 with presence of components in aluminum or light alloys),
- B. iron content (Fe) less than 0.5 mg/l,
- C. copper content (Cu) less than 0.1 mg/l,
- D. total content of chlorides, nitrates and sulfates less than 50mg/l,
- E. must contain conditioning chemicals in concentration sufficient to protect system for a year.

There must be no microbial or bacterial loads in low temperature systems.

Conditioners, additives, inhibitors and anti-freeze fluids can be used only if manufacturer guarantees they are suitable for use in heating systems and they do not cause damage to heat exchanger or other components and/or materials of boiler and system.

Use of generic chemicals not specifically suitable for use in heating systems and/or incompatible with boiler materials and system is forbidden.

Conditioning chemicals must ensure complete deoxygenation of water and contain specific protective agents for yellow metals (copper and its alloys), anti-fouling agents for limescale at least up to 150 ppm CaCO₃, pH neutral stabilizers and, in low temperature systems, specific biocides for use in heating systems.

In systems with continuous intake of oxygen (e.g. floor systems without anti-diffusion pipes, open expansion vessels), or intermittent (e.g. in case of frequent replenishing), a separator must be provided. Regarding domestic hot water (DHW), no type of treatment which could prevent its possible food use can be provided for.

WARNING

- Poison hazard. Ethylene glycol is toxic. Do not use ethylene glycol.
- Never use automotive or standard glycol antifreeze, even ethylene glycol made for hydronic systems.
- Ethylene glycol can attack gaskets and seals used in hydronic systems.
- Use only inhibited propylene glycol solutions certified by fluid manufacturer as acceptable for use with closed water heating system.
- Thoroughly clean and flush any system that used glycol before installing new Boiler.
- Provide user with Material Safety Data Sheet (MSDS) on fluid used.

NOTICE

Do not expose boiler to freezing temperatures.

5.3 Special Conditions

- System piping exposed to freezing conditions: Use inhibited propylene glycol solutions certified by fluid manufacturer for use with closed water heating system. Do not use automotive or ethylene glycol.
- Boiler installed above radiation level (or as required by authority having jurisdiction) shall have low water cutoff protection.
- Boiler used in connection with refrigeration system. Install piping in parallel with boiler, with appropriate valves to prevent chilled medium from entering boiler.

5 - HYDRONIC PIPING

- System piping connected to heating coils located in air handling unit exposed to refrigerated air circulation. Install flow control valves or other automatic means to prevent gravity circulation of boiler water during cooling cycle.

5.4 Storage Tank Connection For Domestic Hot Water Production

- Unit's electronic board is arranged for managing an external storage tank for domestic hot water production.
- See figure 10 for hydronic plumbing.
- Make electrical connections as shown on wiring diagram page 36.
- Boiler's control system recognizes presence of hot water tank probe and automatically configures DHW function, activating display and controls.
- Match Indirect tank heat exchanger and boiler capacity.
- Indirect tank requires dedicated pump. See figure 7 and indirect tank specification to determine pump.
- Incorrect tank size or insufficient flow may result in:
 - F. Unsatisfactory indirect tank performance.
 - G. Boiler short cycling
 - H. Extended DHW calls resulting in delayed response to CH calls.

Figure 7 - Indirect Tank Performance Chart

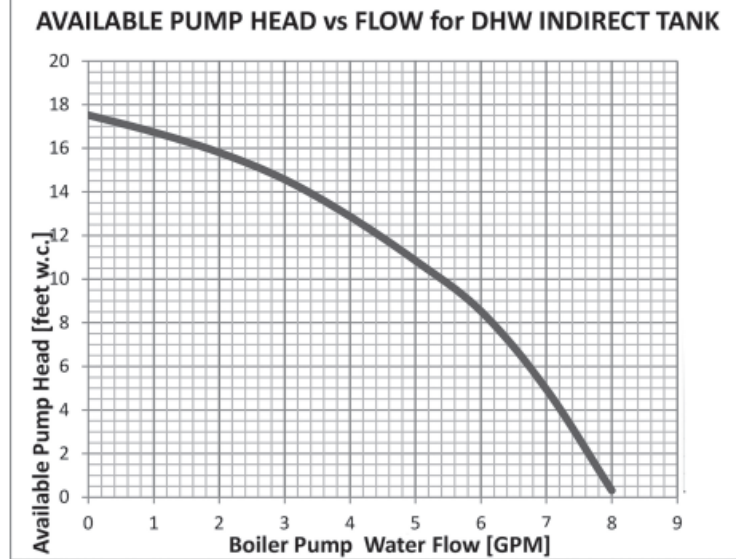

Available pump head Feet water column	Flow US GPM
17.52	0
16.74	1
15.81	2
14.57	3
12.87	4
10.85	5
8.53	6
4.96	7
0.31	8

⚠ WARNING

Burn and Scald Hazard. Safety relief valve could discharge steam or hot water during operation. Install discharge piping per these instructions. Failure to do so could result in death or serious injury.

Figure 8 - Safety Relief Valve & Air Vent (Viewed from front of boiler)

5.5 Safety Relief Valve

NOTICE

Boiler rated at 43.5 psig (.30MPa) maximum allowable working pressure. Boiler provided with 30 psig (.21MPa) safety relief valve.

- Install safety relief valve using pipe fittings provided with boiler. See figure 8.
- Install safety relief valve with spindle in vertical position.
- Do not install shutoff valve between boiler and safety relief valve.
- Install discharge piping from safety relief valve. See figure 9.
 - Use ¾" or larger pipe.
 - Use pipe suitable for temperatures of 375°F (191°C) or greater.
 - Individual boiler discharge piping shall be independent of other discharge piping.

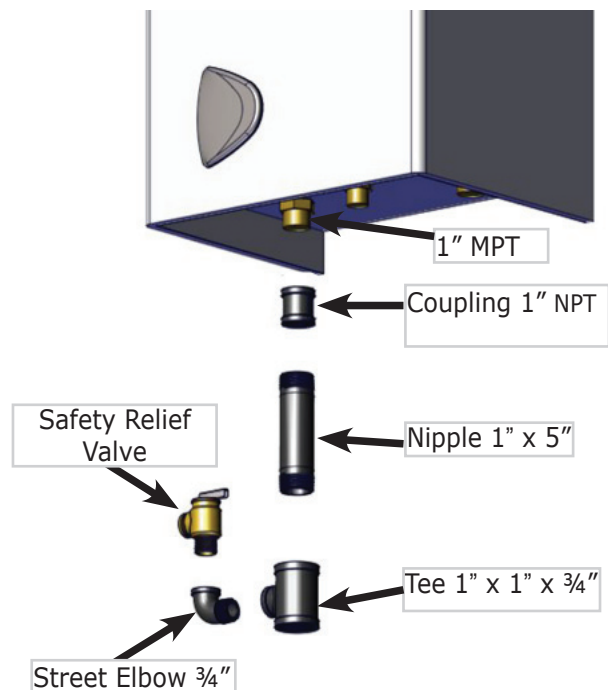

5 - HYDRONIC PIPING

- Size and arrange discharge piping to avoid reducing safety relief valve relieving capacity below minimum relief valve capacity stated on rating plate.
- Run pipe as short and straight as possible to location protecting user from scalding and properly drain piping.
- Install union, if used, close to safety relief valve outlet.
- Install elbow(s), if used, close to safety relief valve outlet and downstream of union (if used).
- Terminate pipe with plain end (not threaded).

Figure 9 - Safety Relief Valve Discharge Piping

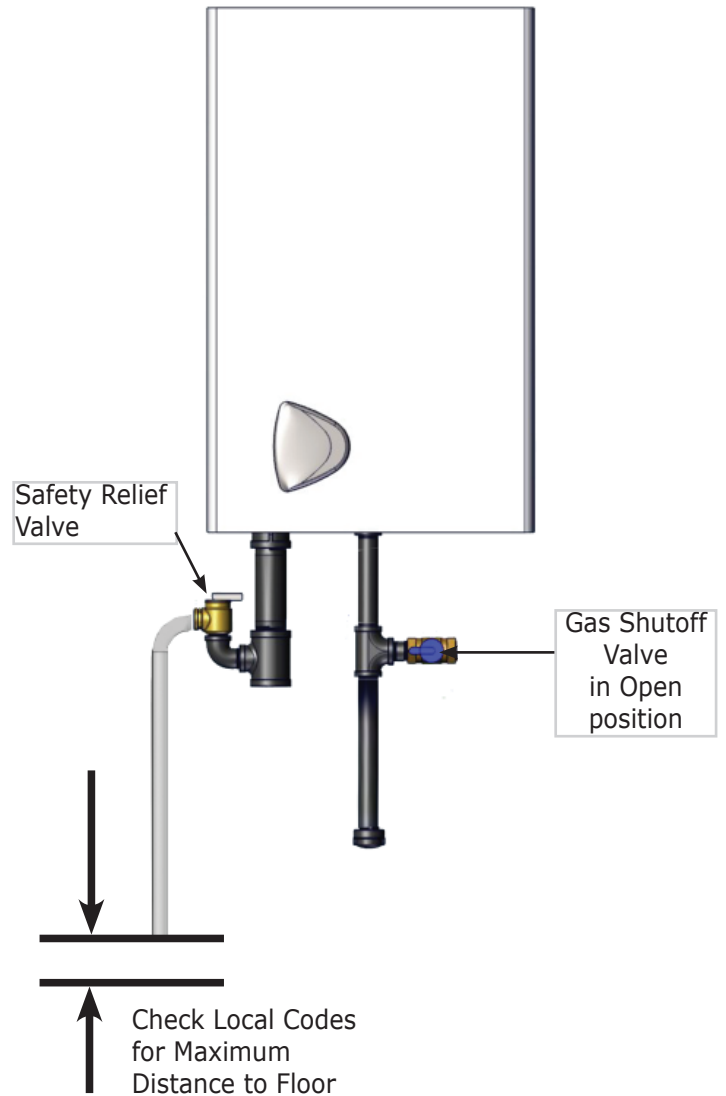
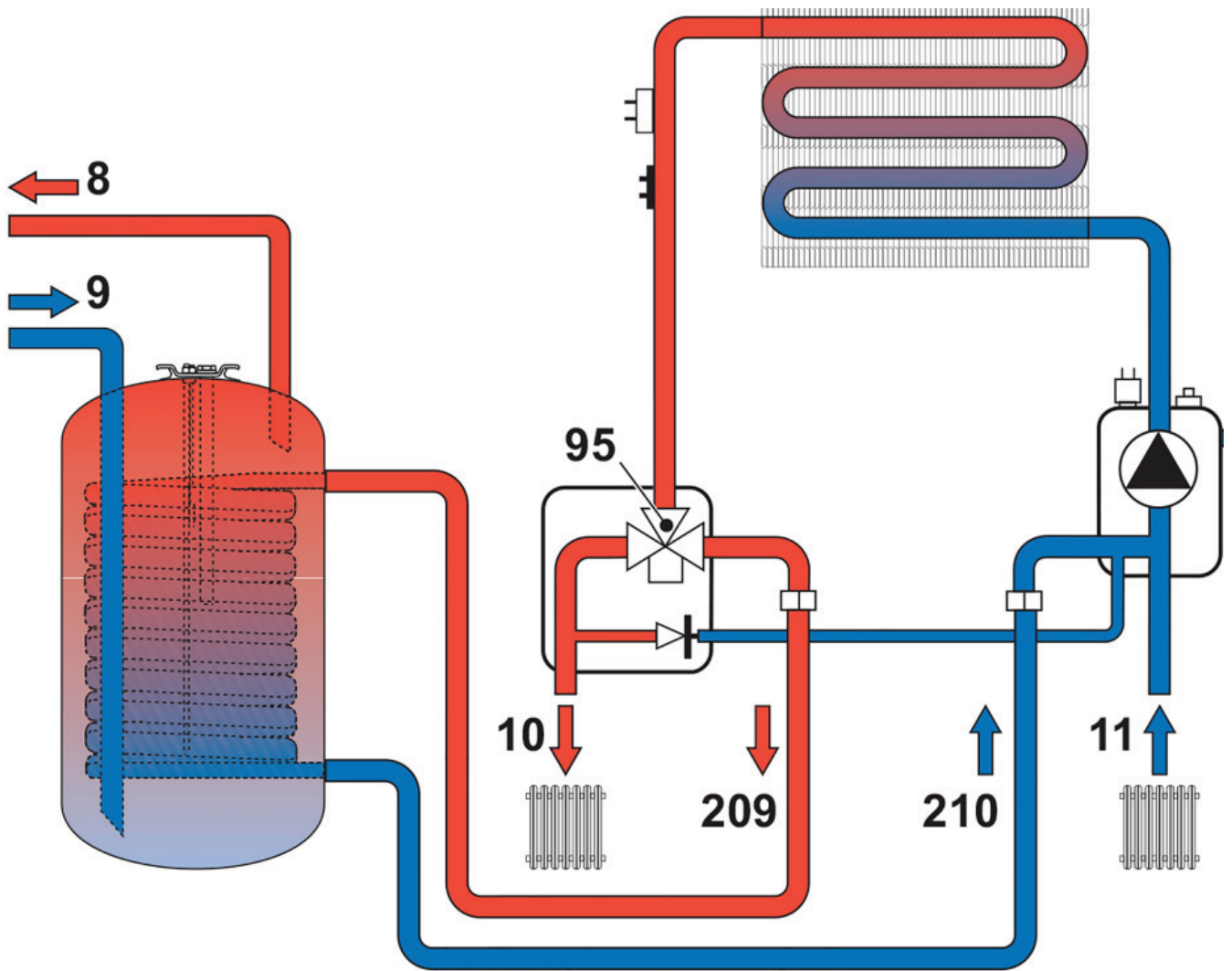

Figure 10 - Hydronic Piping



- 8** Domestic Hot Water Outlet
- 9** Domestic Cold Water Inlet
- 10** Heating System Supply
- 11** Heating System Return
- 95** Diverter Valve
- 209** Hot Water Tank Delivery
- 210** Hot Water Tank Return

6 - COMBUSTION AIR AND VENT PIPING - CATEGORY I (CHIMNEY VENT)

⚠ WARNING

Boiler and venting installations shall be performed by a qualified service agent and in accordance with the appropriate manual. Installing or venting boiler or other gas appliance with improper methods or materials may result in serious injury or death due to fire or to asphyxiation from poisonous gases such as carbon monoxide which is odorless and invisible.

⚠ WARNING

Do not connect boiler to any portion of mechanical draft system operating under positive pressure.

6.1 Check Your Chimney

Chimney must be clean, right size, properly constructed and in GOOD CONDITION.

1. Installation must conform to requirements of the authority having jurisdiction or, in absence of such requirements, to the National Fuel Gas Code, ANSI Z223.1/NFPA 54 and/or Natural Gas and Propane Installation Code, CAN/CSA B149.1.
2. In increaser fitting is required on this boiler for Category I venting, and 4" is minimum permissible vent diameter. This does not imply vent connector is intended to be 4" diameter pipe. Vent connector shall be sized according to appropriate venting tables in the National Fuel Gas Code and may be required to be larger than 4" diameter.

NOTICE

Boiler installation for chimney venting is not complete unless increaser fitting is located and secured.

3. These are Category I and Category III high efficiency boilers with lower stack or exhaust temperature.
4. Venting into masonry chimney without liner, line chimney from top to bottom with either:
 - A. Listed Type B vent pipe
 - B. Listed flexible vent liner
 - C. Poured ceramic liner.
5. Outside chimneys should not be used unless they are (choose one of the following):
 - A. Enclosed in a chase
 - B. Lined with Type B vent pipe
 - C. Use listed flexible vent liner
 - D. Use certified chimney lining system
6. Vent connector from boiler to chimney should run as directly as possible with as few elbows as possible.

7. Common venting shall not be allowed. Boiler and other certified appliances. appliances can share same chimney vent. Consult appropriate Vent Sizing Tables in National Fuel Gas Code for specific requirements of multiple appliance venting.
8. Boiler is only appliance connected to vent, Type B vent pipe is recommended for vent connector.
9. Slope pipe up from boiler to chimney not less than 1/4" per foot (21mm/m).
10. End of vent pipe must be flush with inside face of chimney flue. Use sealed-in thimble for chimney connection.
11. Fasten sections of vent pipe with sheet metal screws to make piping rigid. Use stovepipe wires to support pipe from above.
12. Do not connect to fireplace flue.
13. Do not install damper on this boiler.

Figure 11 - Combustion Air Fitting

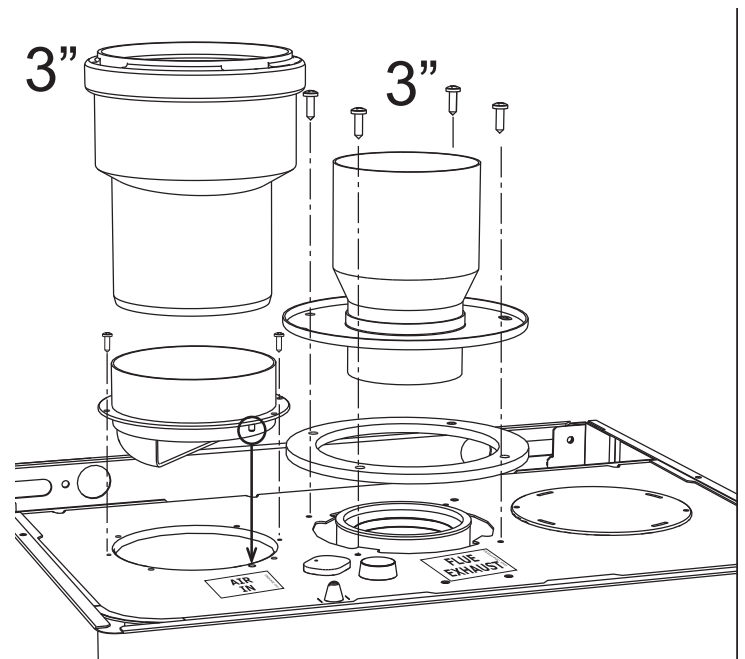

Horizontal Venting requires field supplied appliance adapter for the boiler flue outlet.

Boiler is provided with a 3" vent connection, 3" x 4" increaser must be field sourced for chimney application. This does not mean that the connection to the chimney will always be 4".

6 - COMBUSTION AIR AND VENT PIPING- CATEGORY I (CHIMNEY VENT)

6.2 Minimum Vent Pipe Clearance

- Use Type B vent pipe through crawl space. Where vent pipe passes through combustible wall or partition, use ventilated metal thimble. Thimble should be 4 inches larger in diameter than vent pipe.
- Boiler installed with single wall vent, must have 6" clearance between its surface and any combustible material. New Type B gas vent or flexible liner must be installed in accordance with instructions furnished with vent. Maintain clearances as specified for vent pipe.
- Verify vent pipe is fire-stopped where it goes through floor or ceiling. It should have approved vent cap with clearances from roof. If clearances are less than shown, have vent checked by local authorities. Figure 13, Page 20.
- Vent connectors serving appliances vented by natural draft shall not be connected into any portion of mechanical draft systems operating under positive pressure.

6.3 Removing Existing Boiler From Common Venting System

When an existing boiler is removed from a common venting system, common venting system is likely to be too large for proper venting of the appliances remaining connected to it.

1. At the time of removal of an existing boiler, the following steps shall be followed with each appliance remaining connected to the common venting system placed in operation, while the other appliance remaining connected to the common venting system are not in operation.
2. Seal any unused openings in the common venting system.
3. Visually inspect the venting system for proper size and horizontal pitch and determine there is no blockage or restriction, leakage, corrosion and other deficiencies which could cause an unsafe condition.
4. Insofar as is practical, close all building doors and windows and all doors between the space in which the appliances remaining connected to the common venting system are located and other spaces of the building. Turn on clothes dryers and any appliance not connected to the common venting system. Turn on any exhaust fans, such as range hoods and bathroom exhausts, so they will operate at maximum speed. Do not operate a summer exhaust fan. Close fireplace dampers.
5. Place in operation the appliance being inspected. Follow the lighting instructions. Adjust thermostat so appliance will operate continuously.

6. Test for spillage at the draft hood relief opening after 5 minutes of main burner operation. Use flame of a match or candle, or smoke from a cigarette, cigar, or pipe.
7. After it has been determined that each appliance remaining connected to the common venting system properly vents when tested as outlined above, return doors, windows, exhaust fans, fireplace dampers and any other gas-burning appliance to their previous conditions of use.
8. Any improper operation of the common venting system should be corrected so the installation conforms with the National Fuel Gas Code, ANSI Z223.1/NFPA 54, and/or the Natural Gas and Propane Installation Code, CAN/CSA B149.1. When re-sizing any portion of the common venting system, the common venting system should be re-sized to approach the minimum size determined using the appropriate tables in Chapter 13 of the National Fuel Gas Code, ANSI Z223.1/NFPA 54, and/or the Natural Gas and Propane Installation Code, CAN/CSA B149.1.
9. It is recommended that existing gas vents be checked to be sure they meet local codes.

6.4 Modulating Fan

- Unit is equipped with an advanced combustion air, vent flow control system, with modulating fan and pressure sensor.
- Unit automatically adapts its operation to flue type and length, without requiring adjustments during installation or use of baffles in combustion circuit.
- Unit consistently and automatically regulates combustion air and vent flow according to change in thermal load. Combustion and heat exchange occur in optimum conditions. Unit's thermal efficiency remains high throughout its power range.

6.5 Venting Materials

- See Table 3

Table 3 - Combustion Air and Vent Pipe Fittings Category I (Chimney Vent)

Item	Material	Standards
Vent Pipe & Fittings	Type B Vent	UL 441, ULC S605
	Masonry Chimney - must conform to proper sizing and materials	National Fuel Gas Code, ANSI Z223.1/NFPA 54
Combustion Air	Stainless Steel, PVC, CPVC, PP, Aluminum	ANSI/ASTM D2564, ANSI/ASTM F493, UL 1738/ULC636-08

6 - COMBUSTION AIR AND VENT PIPING OF DIRECT VENT AND CATEGORY III

Induced Draft Boilers

Horizontal (Category III) venting systems installation shall conform to the requirements of the authority having jurisdiction or, in the absence of such requirements, to the National Fuel Gas Code, ANSI Z223.1/NFPA 54, and/or Natural Gas and Propane Installation Code, CAN/CSA B149.1

1. Boilers may be vented horizontally. Vent pipe is pitched down from boiler to vent termination. Do not connect other appliances to this vent.
2. Vent Pipe Material UL Listed - AL294C Stainless Steel vent pipe and fittings.
3. Clearance to Combustible Materials: For stainless steel vent pipe maintain 6" minimum air space clearance to combustible materials.
4. Vent Pipe Size: 3" vent pipe connected directly to the outlet of the induced draft blower.
5. Vent Pipe Length:
 - A. For stainless steel vent pipe, the maximum horizontal vent length is 65 equivalent feet.
 - B. Minimum horizontal vent length is 5 equivalent feet.
 - C. For 3" 90° elbows = 5 equivalent feet of vent length.
6. Vent Termination Fitting: For all vent pipe materials, you may use either:
 - A. 90° elbow pointing down, fitted with a minimum 1/4" mesh screen to keep out rodents and birds. The elbow shall be of the same material and size as vent pipe. The elbow exit should be at least 6" away from exterior wall.-or-
 - B. Concentric side wall vent hood.
7. Vent Pipe Termination Location :
 - A. When venting through combustible walls, combustible clearances must be considered. ECR vent termination, 5612601, is a certified direct vent termination (for Category III venting) providing both the outside vent termination and a double wall pipe for passing through a combustible wall up to 10" thick. Vent terminations by other manufacturers may also be used as long as they are certified for category III venting.
 - B. If the 90° elbow is the termination fitting of choice, then the single wall pipe will be passing through the side wall. For combustible walls, a UL listed thimble shall be used where the single wall pipe passes through the wall.
 - C. For single wall pipe through non-combustible walls, the hole through the wall need only be large enough to maintain the pitch of the vent pipe, and provide proper sealing. A thimble is not required for single wall pipe passing through non-combustible walls.

- D. The venting system shall terminate at least 3 feet (0.9m) above any forced air inlet located within 10 feet (3m). The venting system shall terminate at least 4 feet (1.2m) below, 4 feet (1.2m) horizontally from, or 1 foot (300 mm) above any door, window, or gravity air inlet into any building. The bottom of the vent shall be located at least 12 inches (300mm) above grade. Termination of the vent shall be not less than 7 feet (2.13m) above adjacent public walkway. The vent terminal shall not be installed closer than 3 feet (0.9m) from the inside corner of an L shaped structure. Termination of the vent should be kept at least 3 feet (0.9m) away from vegetation. The venting system shall terminate at least 4 feet horizontally from, and in no case above or below, unless a 4 foot horizontal distance is maintained, from electric meters, gas meters, regulators, and relief equipment.
 - The venting system shall terminate at least 4 feet below any eave, soffit, or roof overhang.
 - The venting system shall not terminate underneath any deck, patio, or similar structure.
 - Put vent on a wall away from the prevailing winter wind. Locate or guard the vent to prevent accidental contact with people or pets.
 - Terminate the vent above normal snow-line. Avoid locations where snow may drift and block the vent. Ice or snow may cause the boiler to shut down if the vent becomes obstructed.
 - Under certain conditions, flue gas will condense, forming moisture. In such cases, steps should be taken to prevent building materials at the vent terminal from being damaged by exhaust of flue gas.

United States - Terminate vent system at least 4 feet (1.22m) horizontally from, and in no case above or below, unless a 4 feet (1.22m) horizontal distance is maintained, from electric meters, gas meters, regulators and relief equipment.

Canada - Terminate vent system at least 6 feet (1.83 m) horizontally from, and in no case above or below, unless a 6 feet (1.83m) horizontal distance is maintained, from electric meters, gas meters, regulators and relief equipment.

8. Joining and Sealing the Vent Pipe: The vent pipe needs to be both watertight and gas tight. Seal all joints and seams following vent pipe manufacture's installation instructions.
9. Support Spacing: Do not restrict thermal expansion movement of the vent. The vent pipe must expand and contract freely with temperature change. Each run of vent piping shall be supported following vent pipe manufacture's instructions.

6 - COMBUSTION AIR AND VENT PIPING OF DIRECT VENT AND CATEGORY III

10. If the horizontal vent must go through a crawl space or other unheated space, the cool temperatures will likely cause the flue gases to continuously condense inside the vent pipe. Do not insulate the vent pipe. It must be visible for monthly inspection. Insure that the vent pipe is properly pitched away from the boiler, with no low spots, so that condensate in the vent will drain away from the boiler. An insulated enclosure or chase, with access for inspection and servicing of the vent, may be required to prevent freezing of liquid condensate. Consult the vent pipe manufacturer's instructions for specific guidelines.
11. At beginning of each heating season and monthly during the heating season, check all vent pipes and vent terminal to make sure there are no obstructions. Periodically clean the screen in the vent terminal.

WARNING

Vent extending through exterior wall shall not terminate adjacent to wall or below building extensions such as eaves, balconies, parapets or decks. Failure to comply could result in death or serious injury.

Table 4 - Combustion Air and Vent Pipe Fittings

Type	Item	Diameter	Min Length	Max Length	Material	Standards
Direct vent	Vent	3"	5 ft	65 ft	AL294C Stainless Steel, Aluminum	UL1738, ULC S636
	Air intake	3"	5 ft	65 ft	Stainelss Steel, PVC, CPVC, PP, Aluminum	ANSI/ASTM D2564, ANSI/ASTM F493, UL 1738/ULC636-08
Category III	Vent	3"	5 ft	65 ft	AL294C Stainless Steel, Aluminum	UL1738, ULC S636

Equivalent Length of Venting Components:

- 5 ft. equivalent for a 3" 90° elbow.**
2 1/2 ft. equivalent for a 3" 45° elbow.

6 - COMBUSTION AIR AND VENTILATION

Provide combustion air and ventilation air in accordance with the section "Air for Combustion and Ventilation," of the National Fuel Gas Code, ANSI Z223.1/NFPA 54, or Sections 8.2, 8.3 or 8.4 of Natural Gas and Propane Installation Code, CAN/CSA B149.1, or applicable provisions of local building codes.

Provide make-up air where exhaust fans, clothes dryers, and kitchen ventilation equipment interfere with proper operation.

National Fuel Gas Code recognizes several methods of obtaining adequate ventilation and combustion air. Requirements of the authority having jurisdiction may override these methods.

- Engineered Installations. Must be approved by authority having jurisdictions.
- Mechanical Air Supply. Provide minimum of 0.35 cfm per Mbh for all appliances located within space. Additional requirements where exhaust fans installed. Interlock each appliance to mechanical air supply system to prevent main burner operation when mechanical air supply system not operating.
- All Indoor Air. Calculate minimum volume for all appliances in space. Use a different method if minimum volume not available.
 - ◇ Standard Method. Cannot be used if known air infiltration rate is less than 0.40 air changes per hour. See Table 5 for space with boiler only. Use equation for multiple appliances.

$$\text{Volume} \geq 50 \text{ ft}^3 \times \text{Total Input [Mbh]}$$
 - ◇ Known Air Infiltration Rate. See Table 3 for space with boiler only. Use equation for multiple appliances. Do not use an air infiltration rate (ACH) greater than 0.60.

$$\text{Volume} \geq 15 \text{ ft}^3/\text{ACH} \times \text{Total Input [Mbh]}$$
 - ◇ Refer to National Fuel Gas Code for opening requirements between connection indoor spaces.

- All Outdoor Air. Provide permanent opening(s) communicating directly or by ducts with outdoors.
 - ◇ Two Permanent Opening Method. Provide opening commencing within 12 inches of top and second opening commencing within 12 inches of bottom enclosure.
 - ◆ Direct communication with outdoors or communicating through vertical ducts. Provide minimum free area of 1 in2 per 4 Mbh of total input rating of all appliances in enclosure.
 - ◆ Communicating through horizontal ducts. Provide minimum free area of 1 in2 per 2 Mbh of total input rating of all appliances in enclosure.
 - ◇ One Permanent Opening Method. Provide opening commencing within 12 inches of top of enclosure. Provide minimum clearance of 1 inch on sides and back and 6 inches on front of boiler (does not supersede clearance to combustible materials).
 - ◇ Combination Indoor and Outdoor Air. Refer to National Fuel Gas Code for additional requirements for louvers, grilles, screens and air ducts.
- Combination Indoor and Outdoor Air. Refer to National Fuel Gas Code for application information. National Gas and Propane Installation Code Requires providing air supply in accordance with:
 - Section 8.2 and 8.3 when combination of appliances has a total input of up to and including 400 Mbh (120kW).
 - ◆ Does not have draft control device.
 - Section 8.4 when combination of appliances has total input exceeding 400 Mbh (120 kW).
 - Refer to Natural Gas and Propane Installation Code for specific air supply requirements for enclosure or structure where boiler is installed, including air supply openings and ducts.

Table 5 - Air Infiltration

Input Mbh	Standard Method	Known Air Infiltration Rate Method (Air Changes Per Hour)					
		0.1	0.2	0.3	0.4	.05	0.6
100	5000	15,000	7,500	5,000	3,750	3,000	2,500
130	6500	19,500	9,750	6,500	4,875	3,900	3,250

Figure 12 - Horizontal Venting Clearances

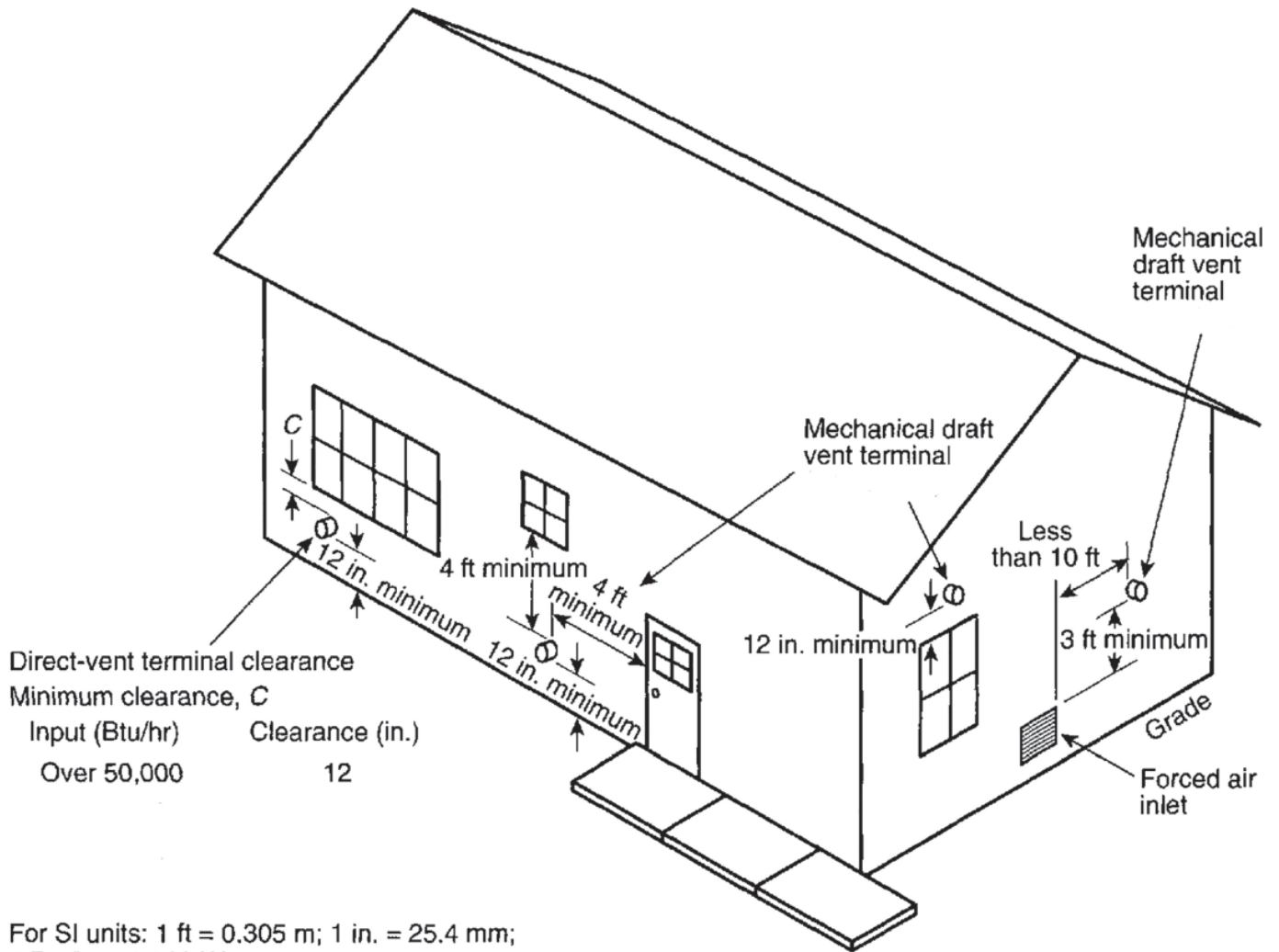

For SI units: 1 ft = 0.305 m; 1 in. = 25.4 mm;
1 Btu/hr = 0.293 W

NOTICE

Maintain 12" (30cm) US, 18" (46cm) Canada clearance above highest anticipated snow level or grade.

Figure 13 - Two Pipe Venting

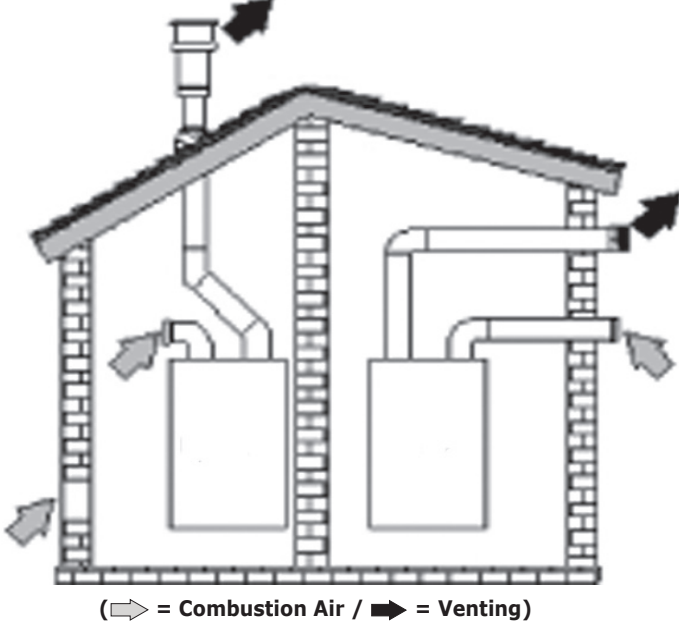
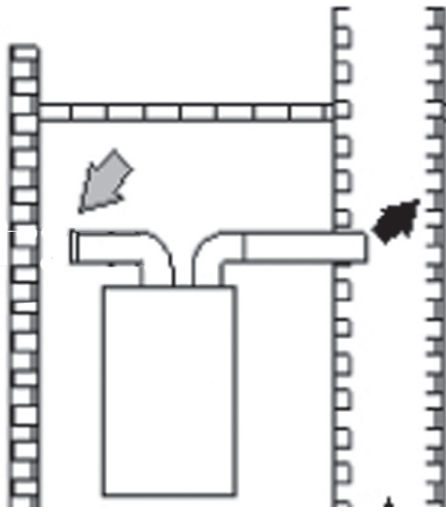

Figure 14 - Chimney Venting with Room Air Single Wall



(⇨ = Combustion Air / ⇨ = Venting)

NOTICE

Refer to section 6.1, numbers 3 through 12, page 15 of this manual for proper installation.

Figure 15 - Chimney Venting with Outside Air Single Wall

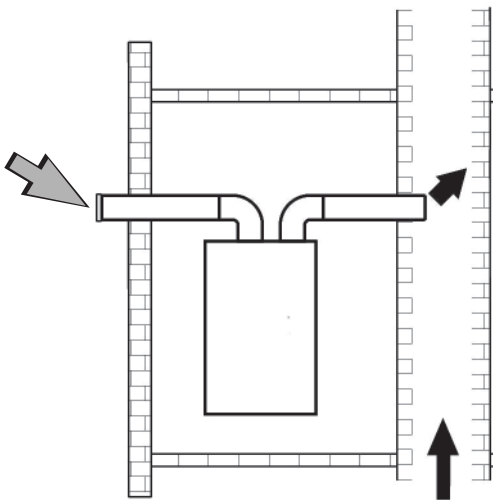

(⇨ = Combustion Air / ⇨ = Venting)

DIRECT VENT BOILER - Boiler constructed and installed so all combustion air is derived directly from outdoors and all vent gases are discharged to outdoors. See Figure 15.

7 - GAS SUPPLY PIPING

⚠ CAUTION

WHAT TO DO IF YOU SMELL GAS

- Do not try to light any appliance.
- Do not touch any electrical switch; do not use any phone in your building.
- Immediately call your gas supplier from a neighbor's phone. Follow gas supplier's instructions.
- If you cannot reach your gas supplier, call the fire department.

7.1 General

- Use piping materials and joining methods acceptable to authority having jurisdiction. In absence of such requirements:
 - USA - National Fuel Gas Code, ANSI Z223.1/NFPA 54
 - Canada - Natural Gas and Propane Installation Code, CAN/CSA B149.1
- Size and install gas piping system to provide sufficient gas supply to meet maximum input at not less than minimum supply pressure. See Table 6.
- Support piping with hooks straps, bands, brackets, hangers, or building structure components to prevent or dampen excessive vibrations and prevent strain on gas connection. Boiler will not support piping weight.
- Use thread (joint) compound (pipe dope) suitable for liquefied petroleum gas.
- Provide sediment trap up stream of gas valve.
- Install manual main shutoff valve outside of jacket. See figure 16.

7.2 Conversion To LP

Refer to Gas Conversion Kit Instructions.

⚠ DANGER

Fire Hazard. Do not use matches, candles, open flames, or other methods providing ignition source. Failure to comply will result in death or serious injury.

7.3 Leak Check Gas Piping

Pressure test boiler and gas connection before placing boiler in operation.

- Pressure test over 1/2 psig (3.5 kPa). Disconnect boiler and its individual gas shutoff valve from gas supply system.
- Pressure test at 1/2 psig (3.5 kPa) or less. Isolate boiler from gas supply system by closing manual gas shutoff valve. See figure 16.
- Locate leakage using gas detector, noncorrosive detection fluid, or other leak detection method acceptable to authority having jurisdiction. Do not use matches, candles, open flames, or other methods that can provide ignition source.
- Correct leaks immediately and retest.

Figure 16 Manual Main Gas Shutoff Valve Outside Boiler Jacket

With Manufacturer Suggested Piping With Drip Leg

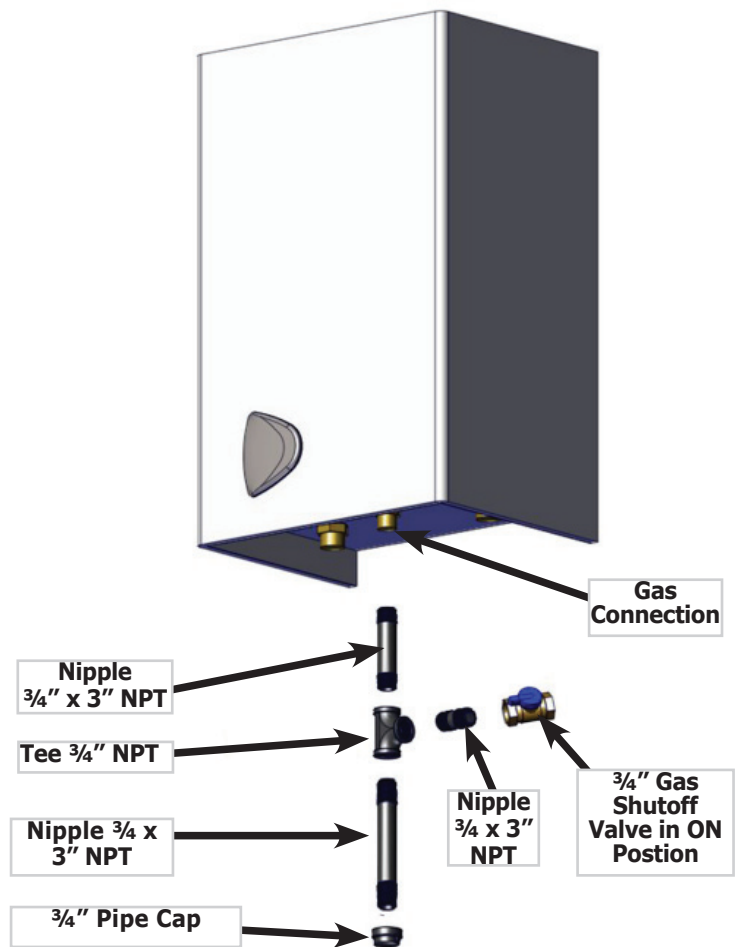

Manufacturer suggested gas piping with drip leg.

Table 6 - Gas Supply Pressure

Gas Supply Pressure	
Natural Gas	
Min.	Max.
3.5" w.c. (0.7 kPa)	14" w.c. (3.3 kPa)

8 - ELECTRICAL CONNECTIONS

⚠ WARNING

Electrical shock hazard. Turn OFF electrical power supply at service panel before making electrical connections. Failure to do so could result in death or serious injury.

8.1 General

Electrically bond boiler to ground in accordance with requirements of authority having jurisdiction. Refer to:

- USA- National Electrical Code, ANSI/NFPA 70.
- Canada - Canadian Electrical Code, Part I, CSA C22.1: Safety Standard for Electrical Installations.

8.2 Line Voltage Connections - Boiler

Provide individual 120V, 15 amp circuit (recommended) with fused disconnect or service switch as required by authority having jurisdiction.

8.3 Central Heating Thermostat

- Use thermostat or boiler system control with dry contacts rated 0.5 amps @ 120 VAC. Boiler control does not provide 24 VAC power to central heating thermostat. Do not use to power 24VAC thermostat.
- Locate and install thermostat per manufacturer's instructions. Maximum wire length is 330 ft (100m) for 22 ga. wire.
- Connect wires to terminals 1 and 2 as shown in figure 17. Wires are interchangeable.

Figure 17 - Terminal Block

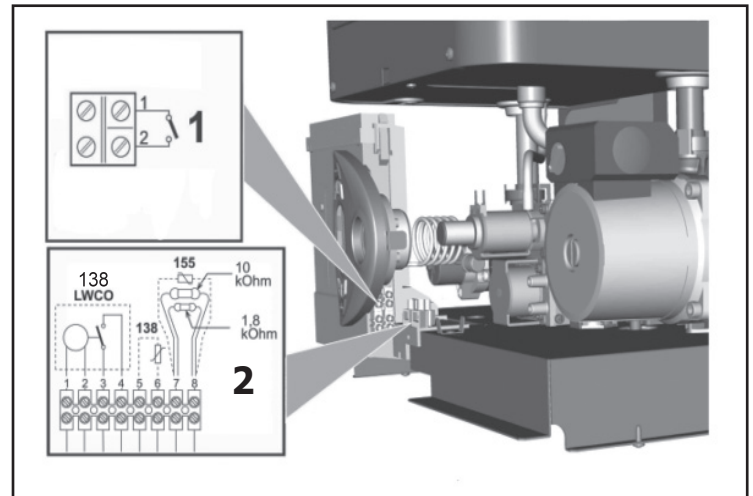

1 - Thermostat or dry contacts

2 - 138 = Optional External Outdoor Reset Sensor
Connections on 5 & 6 terminals
155 = Optional Indirect Tank Sensor
Connections on 7 & 8 terminals
370 = Low Water Cutoff (LWCO) - field source
Connections on 1 & 2 terminals are 120 Volts A/C.
Connections on 3 & 4 are dry contact only.

9 - START UP PROCEDURE

9.1 Fill Boiler With Water And Purge Air

NOTICE

To maintain boiler efficiency and prevent boiling inside the heat exchanger, flush entire heating system until clean.

- Flush heating system, including all heating zones.
- Fill boiler with potable water.
- Fill boiler and system piping with water (or antifreeze-water solution, if used). See antifreeze information Section 5.3 page 11. Purge air from boiler using air vent. Purge air from system piping.
- Inspect system piping and boiler connections. Repair any leaks immediately.
- Activate all heating zones and calls for heat, including CH calls and DHW calls (if available).
- Do not open gas shutoff valve until all air is purged from system.

9.2 Boiler Start-up and Operational Test

1. Verify air is purged from hydronic piping
2. System test pumps - verify each pump is operational
3. Verify gas piping
 - Confirm pressure test. See section 7.3 page 22.
 - Visually inspect piping to determine there are no open fittings or ends, and all valves at unused outlets are closed and plugged/capped.
 - Purge air from piping
 - Check piping and connections for leaks immediately after gas is turned on. Shut off gas supply and make necessary repairs if leaks found.
4. Follow OPERATING INSTRUCTIONS to initiate boiler operation. See section 10.
5. Inspect combustion air and vent piping. Verify pipe is not leaking and terminations are unobstructed and vent gas discharge is not a nuisance or hazard.
6. Verify boiler operates.
7. Check control module operation.
8. Check field sourced limits, low water cutoffs, etc. per manufacturer's instructions.

⚠ WARNING

Asphyxiation hazard. Carbon monoxide is odorless, tasteless, clear colorless gas, which is highly toxic. Carbon monoxide production shall not exceed 400ppm. Failure to follow these instructions could result in death or serious injury.

⚠ WARNING

Asphyxiation hazard. Verify cap is firmly placed on combustion analyzer port to prevent CO emission. Failure to do so could result in death or serious injury.

9.3 Burner Pressure Adjustment

Unit has flame modulation, with two fixed pressure values: minimum and maximum. See sec. 12, page 33.

Connect pressure gauge to pressure point "B" downstream of the gas valve.

1. Remove protection cap "D".
2. Operate boiler in TEST mode.
3. Adjust maximum pressure by turning screw "G" clockwise ↻ to increase pressure and counter clockwise ↻ to decrease.
4. Disconnect one of two connectors "C" from modulation regulator "F" on the gas valve.
5. Adjust minimum pressure by turning screw "E" clockwise ↻ to increase the pressure and counter clockwise ↻ to decrease it.
6. Turn burner on and off, verify minimum pressure remains stable.
7. Reconnect connector "C" detached from modulation regulator "F" on the gas valve.
8. Verify maximum pressure has not changed.
9. Replace protection cap "D".
10. To end TEST mode, repeat activation sequence or wait 15 minutes.

9.4 To Enter Test Mode/Adjust Heating Power

Press CH+/- buttons at the same time for 5 seconds.

- 3 way valve is in CH position and burner is forced at 100%. Boiler automatically exits test mode after 15 minutes or to exit test mode manually press CH +/- buttons together for 5 seconds.
- With Ch +/- buttons you can adjust Max power from (0 to 100%)

9.5 Ignition Adjustment

To adjust ignition, switch boiler to TEST mode (See Start up Procedure). Press DHW buttons to increase or decrease power (min.= 00, max. = 60). Press **RESET** button within 5 seconds and ignition remains set. Exit **TEST** mode.

9 - START UP PROCEDURE

9.6 Check Combustion

Natural Gas

1. Measure input. English units Turn off gas to all other appliances.
 - Activate some heating zones to dissipate heat.
 - Set boiler on high fire.
 - Use ½, 1 or 2 cu ft dial on gas meter. Measure time required for one or more complete revolutions. Measure time for 1-2 minutes.
 - Calculate input.

$$\text{Input (MBH)} = \frac{3600 \times \text{cu ft}}{\text{seconds}}$$

Example: Gas flow from
Meter = 2 cu ft
Measured time = 72 seconds

$$\text{Rate (MBH)} = \frac{3600 \times 2 \text{ cu ft}}{72 \text{ seconds}} = 100 \text{ MBH}$$

Figure 18 - Test Ports

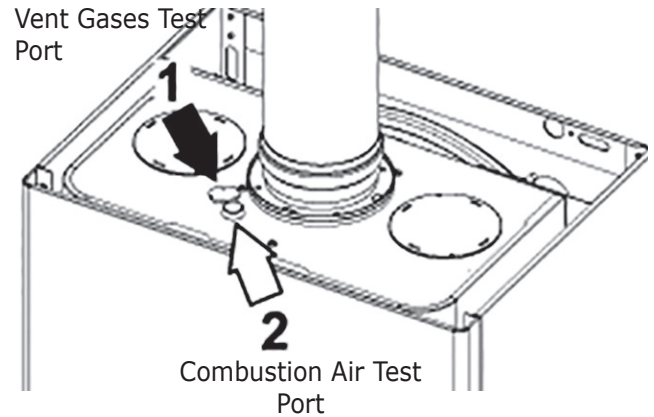
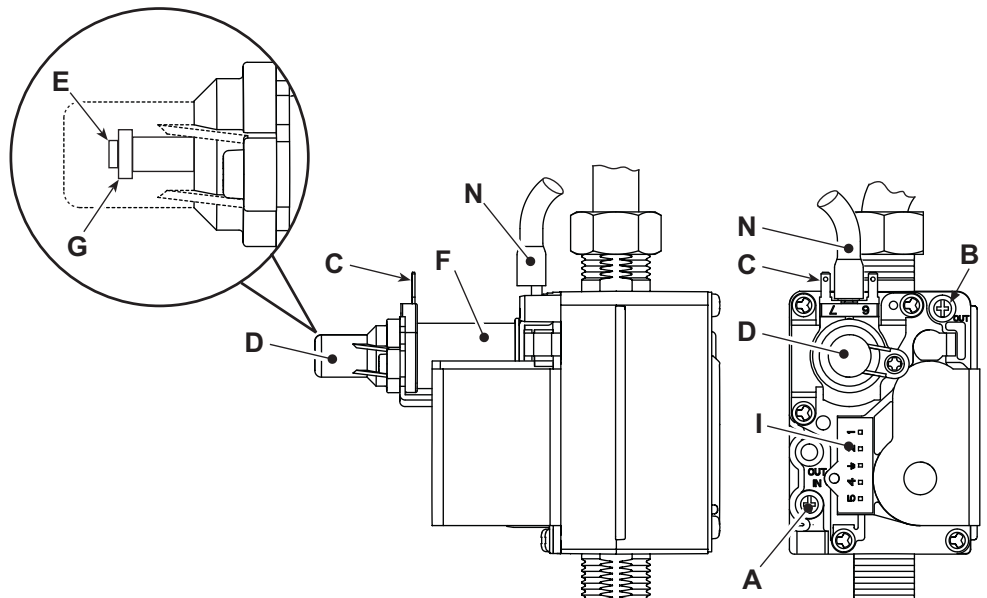

Table 7 - Combustion Table

Combustion Minimum/Maximum	
	<i>Natural Gas</i>
High Fire - CO ₂ at 100 (%)	7.3 - 7.8
Low Fire - CO ₂ at 33 (%)	3.0 - 5.0

Figure 19 - Gas Valve

Two sampling points are available at top of the boiler, one for venting and the other for combustion air. To sample:
Open the air/vent outlet plug.
Insert probes all the way in.
Turn on TEST mode, wait 10 minutes for boiler to stabilize;
Take measurement.



- A** Pressure point upstream
- B** Pressure point downstream
- C** Modureg electrical connection
- D** Protection cap
- E** Minimum pressure adjustment
- F** Modureg
- G** Maximum pressure adjustment
- I** Gas valve electrical connection
- N** Compensation tube

10 - OPERATING INSTRUCTIONS

⚠ WARNING

If you do not follow these instructions exactly, a fire or explosion may result causing property damage, personal injury or loss of life.

- This appliance is equipped with an ignition device which automatically lights burner. **Do NOT try to light this burner by hand.**
- Before operating smell all around appliance area for gas. Be sure to smell next to floor because some gas is heavier than air and will settle to the floor.
- **Use only your hand to turn the gas shutoff valve.** Never use tools. If valve will not turn by hand, do not try to repair it, call a qualified service technician. Force or attempted repair may result in fire or explosion.
- **Do not use this appliance if any part has been under water.** Immediately call a qualified service technician to inspect appliance and to replace any part of control system and any gas control which has been under water.

10.1 OPERATING INSTRUCTIONS

Stop! Read Safety information above.

- Set thermostat to lowest setting.
- Turn "**OFF**" all electrical power to appliance.
- This appliance is equipped with an ignition device which automatically lights the burner. **Do not try to light burner by hand!**
- Turn gas shutoff valve ↻ to closed position. Handle should be perpendicular to gas pipe.
- Wait 5 minutes for any gas to clear. Smell for gas, including near floor. If you smell gas, **STOP!** Follow instructions on this page: "**What To Do If You Smell Gas.**" If you do **not** smell gas, go to next step.
- Turn gas shutoff valve ↻ to open position. Handle should be parallel to gas pipe.
- Turn "**ON**" electrical power to appliance.
- Set thermostat to desired setting.
- If the appliance will not operate, follow instructions TO TURN OFF GAS TO APPLIANCE and call your service technician or gas supplier.

⚠ CAUTION

WHAT TO DO IF YOU SMELL GAS

- Do not try to light any appliance.
- Do not touch any electrical switch; do not use any phone in your building.
- Immediately call your gas supplier from a neighbor's phone. Follow the gas supplier's instructions.
- If you cannot reach your gas supplier, call the fire department.

10.2 TO TURN OFF GAS TO APPLIANCE

- Set thermostat to lowest setting.
- Turn "**OFF**" all electric power to appliance if service is to be performed.
- Turn gas shutoff valve handle ↻ to closed position. Handle should be perpendicular to gas pipe.

Figure 20 Gas Shutoff Valve - Open Position

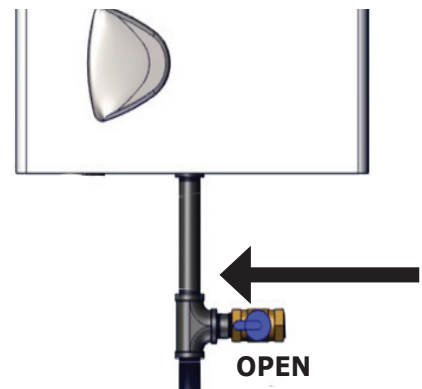
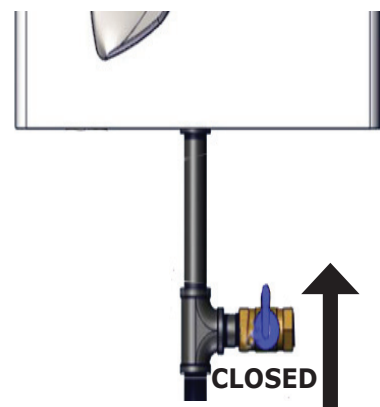

Figure 21 Gas Shutoff Valve - Closed Position



10 - OPERATING INSTRUCTIONS

10.3 Checks During Operation

- Boiler is arranged for connection to an external storage tank for hot water production (optional). All functions relevant to domestic hot water production are only active with the optional water tank connected.
- Check for leaks in piping systems. Correct immediately if found.
- Check the efficiency of the flue gases and combustion air ducts while the boiler is working.
- Check water is circulating between boiler and systems.
- Verify the gas valve modulates correctly in both heating and hot water production phases.
- Check proper ignition of the boiler by turning it on and off with the room thermostat.
- Check parameters are programmed correctly and perform any required customization (compensation curve, power, temperatures, etc.)

10.4 Control Panel

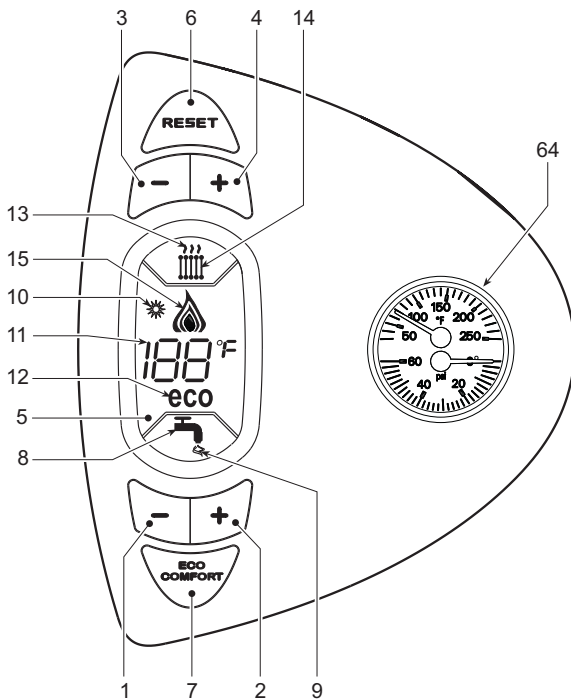

Key

- 1 = DHW Temperature Setting Decrease Button
- 2 = DHW Temperature Setting Increase Button
- 3 = Heating System Temperature Setting Decrease Button - CH
- 4 = Heating System Temperature Setting Increase Button - CH
- 5 = Display
- 6 = Summer/Winter Mode Selection - Reset Button
- 7 = Unit On/Off - Economy/Comfort Mode Selection Button
- 8 = DHW Symbol
- 9 = DHW Mode
- 10 = Summer Mode
- 11 = Multifunction - Temperature
- 12 = Eco (Economy) Mode
- 13 = Heating
- 14 = Heating Symbol
- 15 = Burner On And Actual Power
- 64 = C.H. Temperature Pressure Gauges

10.5 Indicator During Operation

Heating

Call for heat (generated by Room Thermostat) is indicated by hot air flashing above radiator symbol on the control.

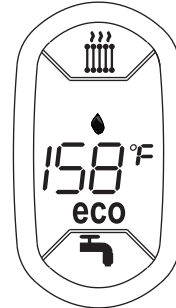

Hot water

If optional tank sensor is installed call for hot water is indicated by hot water flashing under the tap on the control.



10.6 Turning on and off

NO electrical power to the boiler

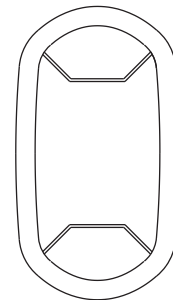

The antifreeze system does not work when power and/or gas to the unit are turned off. To avoid damage caused by freezing during long idle periods in winter, it is advisable to drain all water from the boiler, DHW circuit and system; or drain just the DHW circuit and add a suitable antifreeze to the heating system. See Section 5.3 page 11.

10 - OPERATING INSTRUCTIONS

Boiler Ignition

Supply unit with electricity.

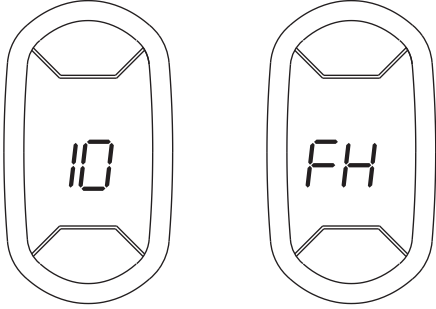

Boiler ignition

For 120 seconds display will show FH which identifies the air venting cycle for the heating system. During the first 5 seconds the display will show the software release of the card also.

Open the gas valve before the boiler.
When FH vanishes, boiler is ready to automatically work whenever indirect tank sensor or room thermostat requests heating.

Turning the boiler off

Press the button below (see item 7 on the control panel display) for 5 seconds.

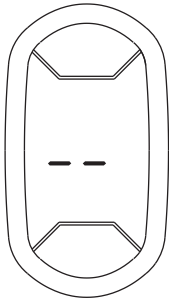

When the boiler is turned off, the electronic board is still powered.
Domestic hot water and heating operation are disabled. The antifreeze system remains activated.
To re-light the boiler, press the button (see item 7 on the control panel display) again for 5 seconds.



Boiler will be immediately ready to operate whenever indirect tank sensor or room thermostat demand.

Summer/Winter Switch over

NOTICE

Activating this button will keep your boiler from operating. Verify that boiler is not required to run Domestic Hot Water (DHW) needs.

Press the button for 2 seconds.

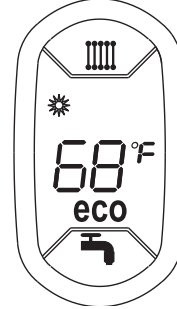

Display will activate Summer symbol (see item 10 on the control panel display). If optional tank sensor is installed boiler will activate DHW circuit only. Antifreeze system stays on.
To turn off Summer mode, press button again for 2 seconds.

Heating temperature setting

Use heating buttons (see items 3 and 4 on the control panel display) to change the temperature from minimum of 86°F (30C) to a maximum of 185°F (85C); it is advisable to not operate boiler below 113°F (45C).

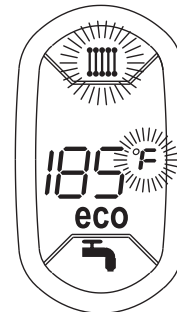

Domestic hot water temperature adjustment

Operate DHW buttons (see items 1 and 2 on the control panel display) to vary the temperature from a minimum of 50°F (40C) to a maximum of 149°F (55C).

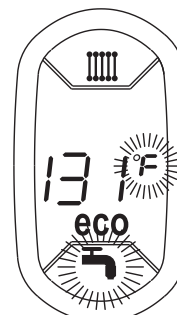

10 - OPERATING INSTRUCTIONS

Hot water tank exclusion (economy)

Hot water tank temperature maintaining/heating can be excluded by the user. If excluded, domestic hot water will not be delivered.

The hot water tank can be deactivated by the user (ECO mode) by pressing the ECO/COMFORT button (detail 7 - control panel display). In ECO mode the display activates the ECO symbol (detail 12 - on control panel display). To activate COMFORT mode, press the ECO/COMFORT button (detail 7 - on control panel display) again.

Sliding temperature

- When the optional external probe is installed, the boiler control system operates with "Sliding Temperature". In this mode, the temperature of the heating system is controlled according to the outside weather conditions, in order to ensure high comfort and energy saving throughout the year.
- As the outside temperature increases the system delivery temperature decreases according to a specific "compensation curve".
- With Sliding Temperature adjustment, the temperature set with the heating buttons (details 3 and 4 on control panel display) become the maximum system delivery temperature.
- Manufacture recommends setting the maximum value to allow system adjustment throughout its useful working range.
- Boiler must be adjusted at time of installation by qualified service agent. Adjustments can be made by user to improve comfort.

Compensation curve and curve offset

Press the button (see item 6 on the control panel display) for 5 seconds once to display the actual compensation curve, which can be modified with the **DHW buttons** (see items 1 and 2 on the control panel display).

Adjust the required curve from 1 to 10 according to the characteristic.

By setting the curve to 0, sliding temperature adjustment is disabled.

Compensation curve

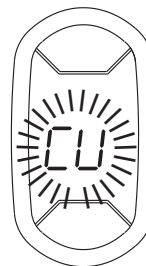

Press the heating buttons (see items 3 and 4 on the control panel display) to access parallel curve offset modifiable with the DHW buttons (see items 1 and 2 on the control panel display).

Parallel curve shift

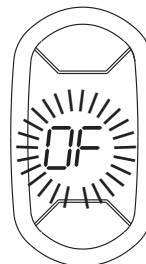

10 - OPERATING INSTRUCTIONS

Press the button (see item 6 on the control panel display) for 5 seconds again to exit parallel curve adjustment mode. If the room temperature is lower than the required value, it is advisable to set a higher order curve and vice versa. Proceed by increasing or decreasing in steps of one and check the result in the room.

Compensation curves

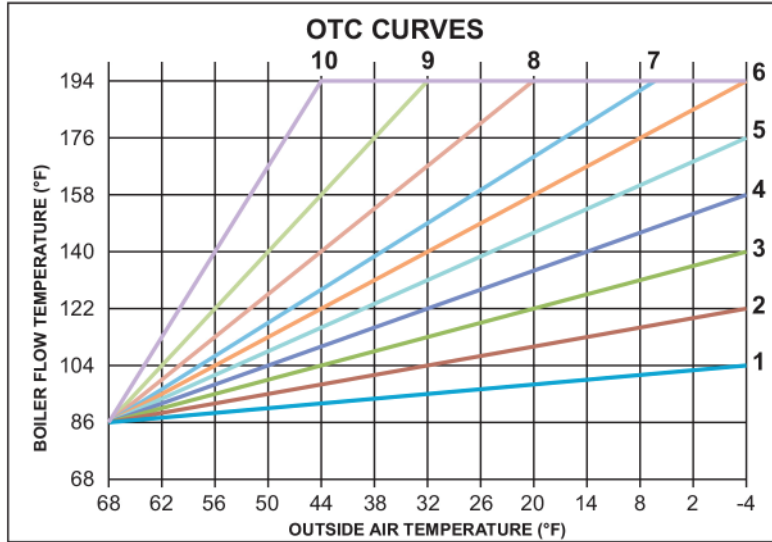

- Compensation curves

OFFSET = 68

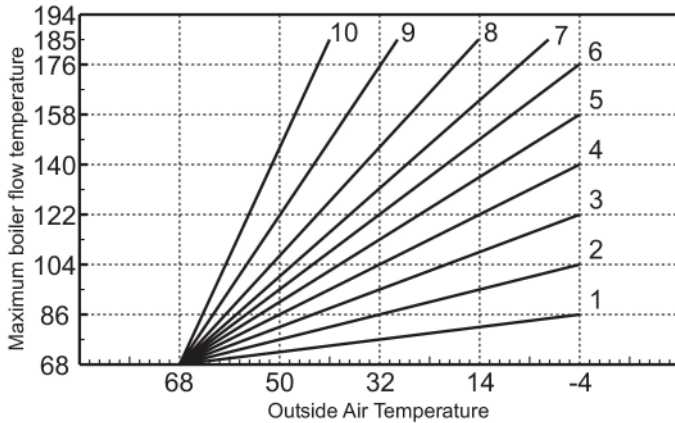

OFFSET = 104

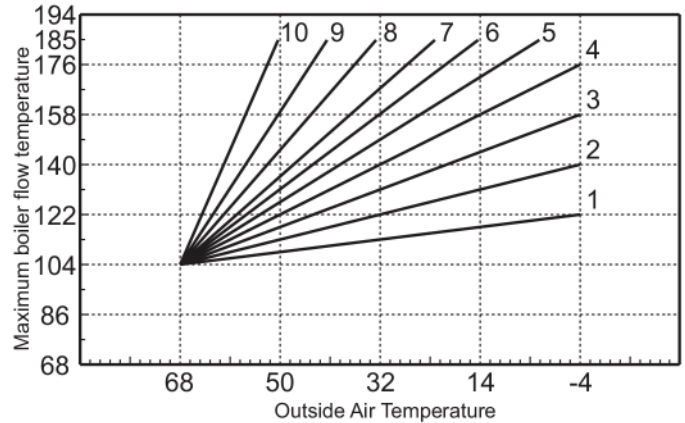

Heating Temperature Adjustment	Adjustment can be made from the boiler control panel.
Domestic Hot Water Temperature	Adjustment can be made from the boiler control panel.
Summer/Winter Switchover	Summer mode has priority over a possible heating demand.
Eco/Comfort Selection	On disabling DHW from the menu, the boiler selects the Economy mode. In this condition, the button 7 from control panel display is disabled.
	On enabling DHW from menu, the boiler selects the Comfort mode. In this condition it is possible to select on of the two modes with the button 7 from control panel display.
Sliding Temperature	Boiler card manages Sliding Temperature adjustment: the boiler card Sliding Temperature has priority.

Water system pressure adjustment

The filling pressure with system cold, read on the boiler water gauge, must be approximately 11 psi.
If the system pressure falls to values below minimum, the boiler control will activate fault F37.

Low system pressure fault

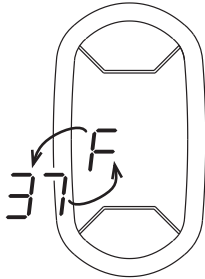

Once the system pressure is restored, the boiler will activate the 120-second air venting cycle indicated on the display by FH.

TEST mode (heating power = 100%)

Press the heating buttons simultaneously for 5 seconds to turn on TEST mode. The boiler will ignite at the maximum heating power set as described in the following paragraph. On the display, the heating and tap water symbols will blink; alongside, it will show the heating power and the ignition power respectively.

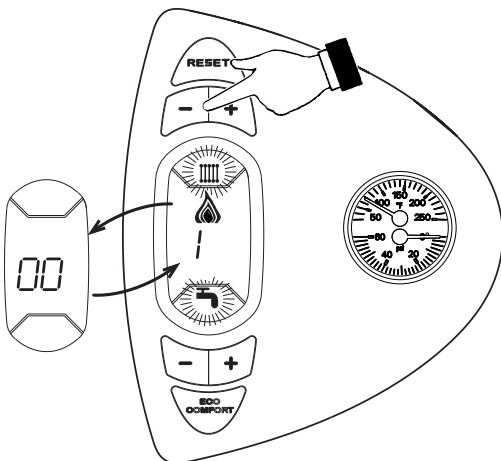

To turn off TEST mode, repeat the sequence for turning it on.

11 - GENERAL MAINTENANCE AND CLEANING

11.1 Beginning of Each Heating Season

- Check boiler area is free from combustible materials, gasoline, and other flammable vapors and liquids.
- Visually inspect combustion air and vent piping for proper operation. Check for and remove any obstruction to flow of combustion air or vent gases. Immediately repair or replace pipe showing deterioration or leakage. Reassemble per instructions in section 6. Ensure proper reassembly and resealing of system.
- Test safety relief valve for proper operation. Refer to valve manufacturer's instructions packaged with relief valve.
- Examine flue passages in heat exchanger, burner and cleaning (if necessary) by following instructions in "Annual Inspection and Cleaning of Boiler Components" in this section.
- Circulator pump and combustion air blower motor furnished with boiler are permanently lubricated from factory and require no further lubrication. Lubricate field sourced pumps and/or motors according to pump and/or motor manufacturer's instruction.
- Check following components are operating properly and are free of blockages or obstructions:
 - air vent;
 - check air inlet for blockage and clean as required;
 - check boiler for any sign of leaks.
 - Check heating system expansion tank.
 - Check the Air pressure tubing

11.2 Annual Shut Down Procedure

- Follow instructions "To Turn Off Gas To Appliance" unless boiler is also used to supply domestic hot water. See section 10, page 26.
- Drain system completely if system does not have antifreeze when heating system is to remain out of service during freezing weather.

WARNING

Following service procedures must be performed by qualified service agent. Boiler owner shall not attempt these steps. Failure to do so could result in death or serious injury.

11.3 Annual Inspection and Cleaning of Boiler Components

- Burner and heat exchanger inspection and cleaning.
 - Remove any remaining loosened sediment using shop vacuum with snorkel attachment.

12 - RATINGS AND CAPACITIES

Data	Unit	CHB100	CHB130
Boiler category		Category I - III	Category I - III
Type of Gas		Natural Gas	Natural Gas
Maximum Input 0-2000 Ft	Btu/hr	100000	130000
	kW	29.3	38.2
Maximum Input 2000-4500 Ft	Btu/hr	90000	117000
	kW	26.4	34.3
Minimum Input 0-2000 Ft	Btu/hr	31500	43500
	kW	9.3	12.8
Minimum Input 2000-4500 Ft	Btu/hr	28300	39000
	kW	8.3	11.5
Max Inlet Gas Pressure	"wc	10.5	10.5
	kPa	2.61	2.61
Min Inlet Gas Pressure	"wc	3.5	3.5
	kPa	0.87	0.87
Manifold gas pressure Max input	"wc	5.22	4.82
	kPa	1.3	1.2
Manifold gas pressure Min input	"wc	0.59	0.59
	kPa	0.15	0.15
D.O.E Heating Capacity	Btu/hr	85000	110000
	kW	24.9	32.2
Net AHRI Output	Btu/hr	73000	96000
	kW	21.4	28.1
Electrical input	A	120V / 60Hz / <12A	120V / 60Hz / <12A
Orifice Size 0-5500 ft		1.35mm	1.35mm
MAWP WATER	PSI	43.5	43.5
MAX. WATER TEMP.	°F	195°F	195°F
Maximum Input LP 0-2000 Ft	Btu/hr	100000	130000
	kW	29.3	38.2
Minimum Input LP 0-2000 Ft	Btu/hr	36000	49000
	kW	10.6	14.4

Table 8 - Sea Level Ratings

 SEA LEVEL RATINGS NATURAL AND PROPANE GASES					
Size	Boiler Input Rate (MBH) ⁽¹⁾		Heating Capacity (MBH) ⁽¹⁾⁽²⁾	Net AHRI Rating, Water (MBH) ⁽¹⁾⁽³⁾	AFUE ⁽²⁾
	Maximum	Minimum			
CHB-100	100	31.5	85	73.0	85
CHB-130	130	43.5	110	96.0	85

⁽¹⁾ 1000 Btu/hr (British Thermal Units Per Hour)
⁽²⁾ Heating Capacity and AFUE (Annual Fuel Utilization Efficiency) are based on DOE (Department of Energy) test procedures.
⁽³⁾ Net AHRI Ratings based on piping and pickup allowance of 1.15. Contact Technical Support before selecting boiler for installations having unusual piping and pickup requirements, such as intermittent system operation, extensive piping systems, etc.

12.1 Ratings and Capacities

- Constructed and hydrostatically tested for maximum allowable working pressure of 43.5 psig (pounds per square inch gauge) 43.5 psig (.30MPa) in accordance with ASME Boiler and Pressure Vessel Code, Section IV, Rules for Construction of Heating Boilers.
- USA - Input rates are derated 4% for each 1000 ft (300m) above sea level, beyond 2000 ft (600m).
- CANADA - Ratings in table 13 used for elevations up to 2000 ft (600m) above sea level
 - For elevations between 2000 ft (600m) and 4500 ft (1350m), derate 10% using high altitude kit.
 - Contact Provincial authority having jurisdiction for installations above 4500 feet (1350 m) above sea level.

Diagrams

Pressure - power diagrams

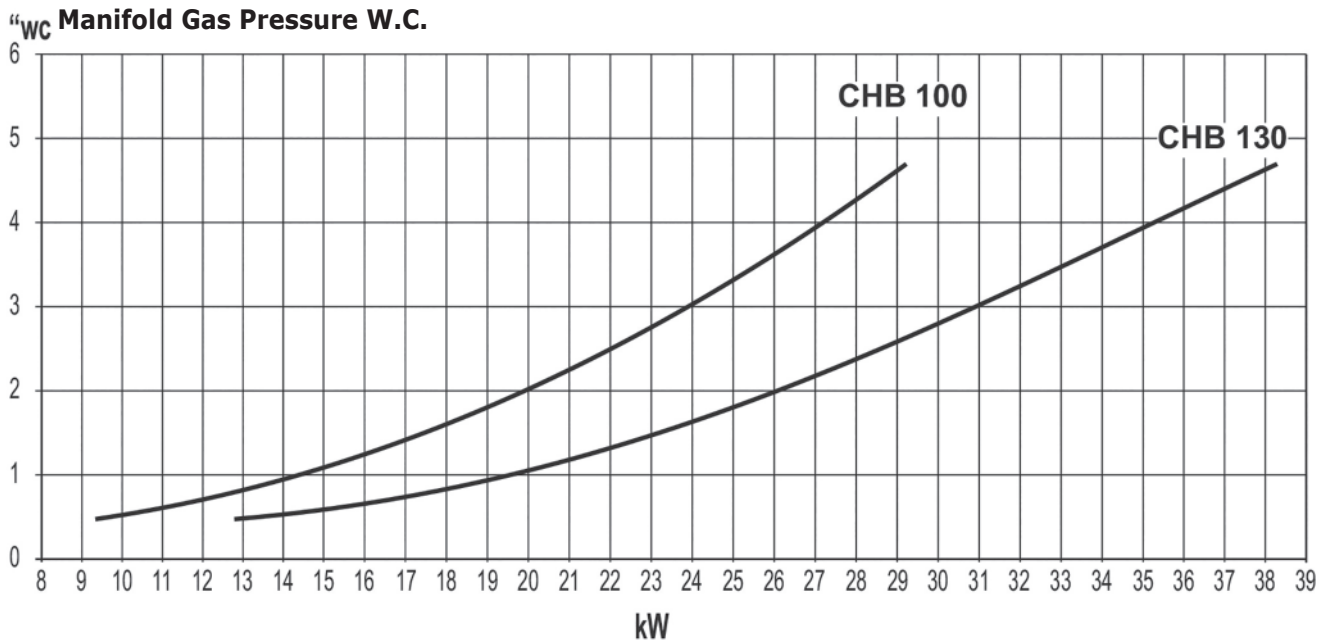

A LPG
B NATURAL GAS

Losses of load / head of circulators

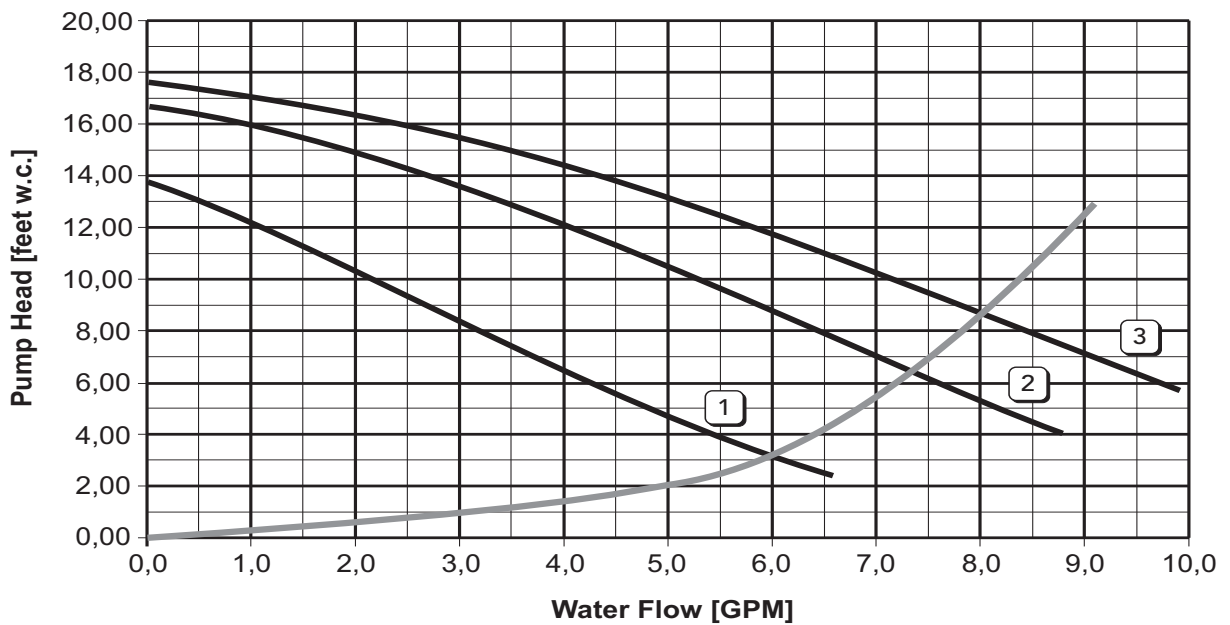

A Boiler losses of head
1 - 2 - 3 Circulator speed

13 - TROUBLE SHOOTING

Diagnosics

The boiler is equipped with an advanced self-diagnosis system. In case of a boiler fault, the display will flash indicating the fault code.

There are faults that cause permanent shutdown (marked with the letter "A"): to restore operation just press the RESET button for 1 second or RESET; if the boiler fails to start, it is necessary to first eliminate the fault.

Other faults (marked with the letter "F") cause temporary shutdowns that are automatically reset as soon as the value returns within the boiler's normal working range.

Table of faults

- List of faults

Fault code	Fault	Possible cause	Cure
A01	No burner ignition	No gas	Check the regular gas flow to the boiler and that the air has been eliminated from the pipes
		Ignition/detection electrode fault	Check the wiring of the electrode and that it is correctly positioned and free of any deposits
		Faulty gas valve	Check the gas valve and replace it is necessary
		Ignition power too low	Adjust the ignition power
A02	Flame present signal with burner off	Electrode fault	Check the ionisation electrode wiring
		Card fault	Check the card
A03	Overtemperature protection activation	Heating sensor damaged	Check correct heating sensor positioning and operation
		No water circulation in the system	Check the circulating pump
		Air in the system	Vent the system
F05	The air pressure transducer does not receive a sufficient minimum value within 25 seconds	Incorrect air pressure transducer wiring	Check the wiring
		Flue not correctly sized or obstructed	Check the length of flue and that it is clean
A06	No flame after the ignition stage	Low pressure in the gas system	Check the gas pressure
		Burner minimum pressure setting	Check the pressures
F10	Delivery sensor 1 fault	Sensor damaged	Check the wiring or replace the sensor
		Wiring shorted	
		Wiring disconnected	
F11	DHW sensor fault	Sensor damaged	Check the wiring or replace the sensor
		Wiring shorted	
		Wiring disconnected	
F14	Delivery sensor 2 fault	Sensor damaged	Check the wiring or replace the sensor
		Wiring shorted	
		Wiring disconnected	
A15	Air signal protection activation	Fault F05 generated 5 times in the last 15 minutes	See fault F05
F34	Supply voltage under 170V.	Electric mains trouble	Check the electrical system
F35	Faulty mains frequency	Electric mains trouble	Check the electrical system
F37	Incorrect system water pressure	Pressure too low	Fill the system
		Sensor damaged	Check the sensor
F39	External probe fault	Probe damaged or wiring short circuit	Check the wiring or replace the sensor
		Probe disconnected after activating the sliding temperature	Reconnect the external probe or disable the sliding temperature
A41	Sensor positioning	Delivery sensor detached from the pipe	Check correct heating sensor positioning and operation
F42	Heating sensor fault	Sensor damaged	Replace the sensor
F43	Exchanger protection activation.	No system H ₂ O circulation	Check the circulating pump
		Air in the system	Vent the system
A44	DHW sensor disconnected	Sensor disconnected	Check the correct positioning and operation of the DHW sensor.
A48	Air signal protection activation	Fault F05 for 150 seconds	See Fault F05
F50	Modulation regulator fault	Wiring disconnected	Check the wiring
F51	Low water cutoff warning	Pressure too low	Fill the system
		Low water cutoff damaged	Check the contact

WIRING DIAGRAM

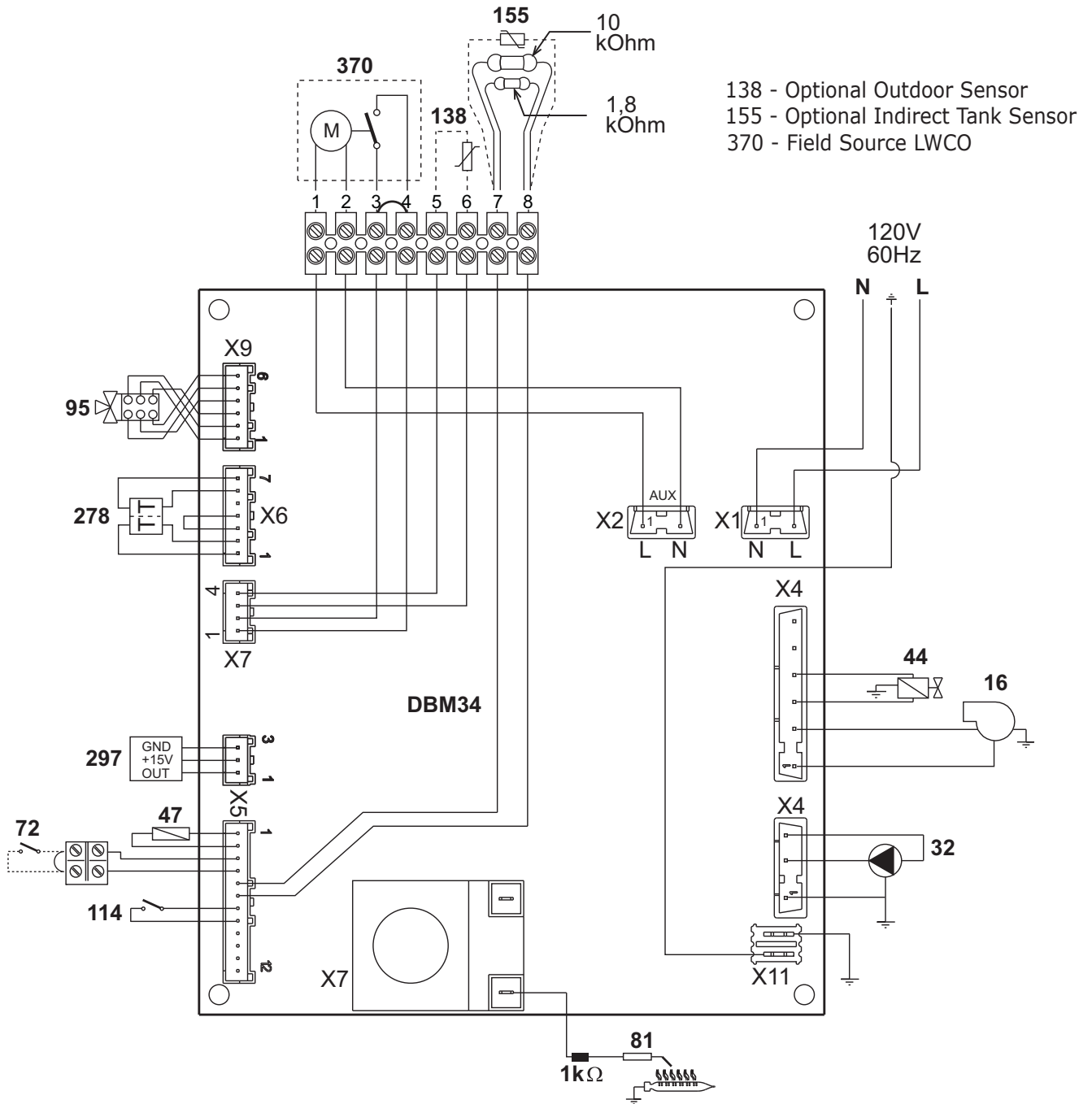

Important: Before connecting the **room thermostat**, remove the jumper on terminal block.

Key

- | | | | |
|------------|----------------------------------|------------|--|
| 16 | Modulating fan | 155 | Hot water tank temperature probe (field sourced) |
| 32 | Heating circulating pump | 278 | Double sensor (Safety + Heating) |
| 42 | DHW temperature sensor (see kit) | 297 | Air pressure transducer |
| 44 | Gas valve | 370 | Low Water Cutoff (LWCO) - (field sourced) |
| 47 | Modulation Regulator (24V) | | |
| 72 | Room thermostat (field sourced) | | |
| 81 | Ignition/detection electrode | | |
| 114 | Water pressure switch | | |
| 138 | External probe (not fitted) | | |

REPAIR PARTS LIST - CHB-100

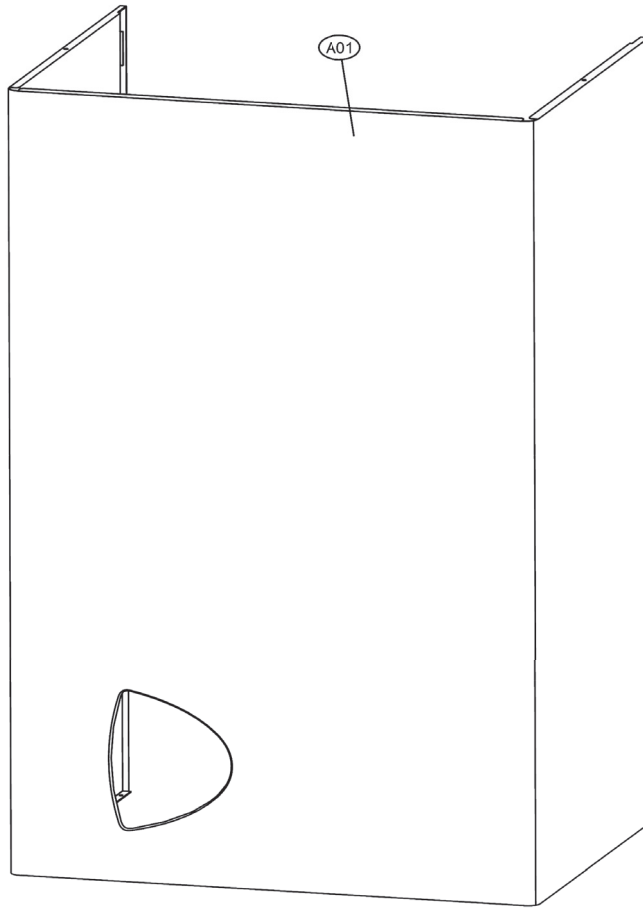

KEY	Part Number	Description	Qty
A01	FE3980B830	CASING "CTR"	1

REPAIR PARTS LIST - CHB-100

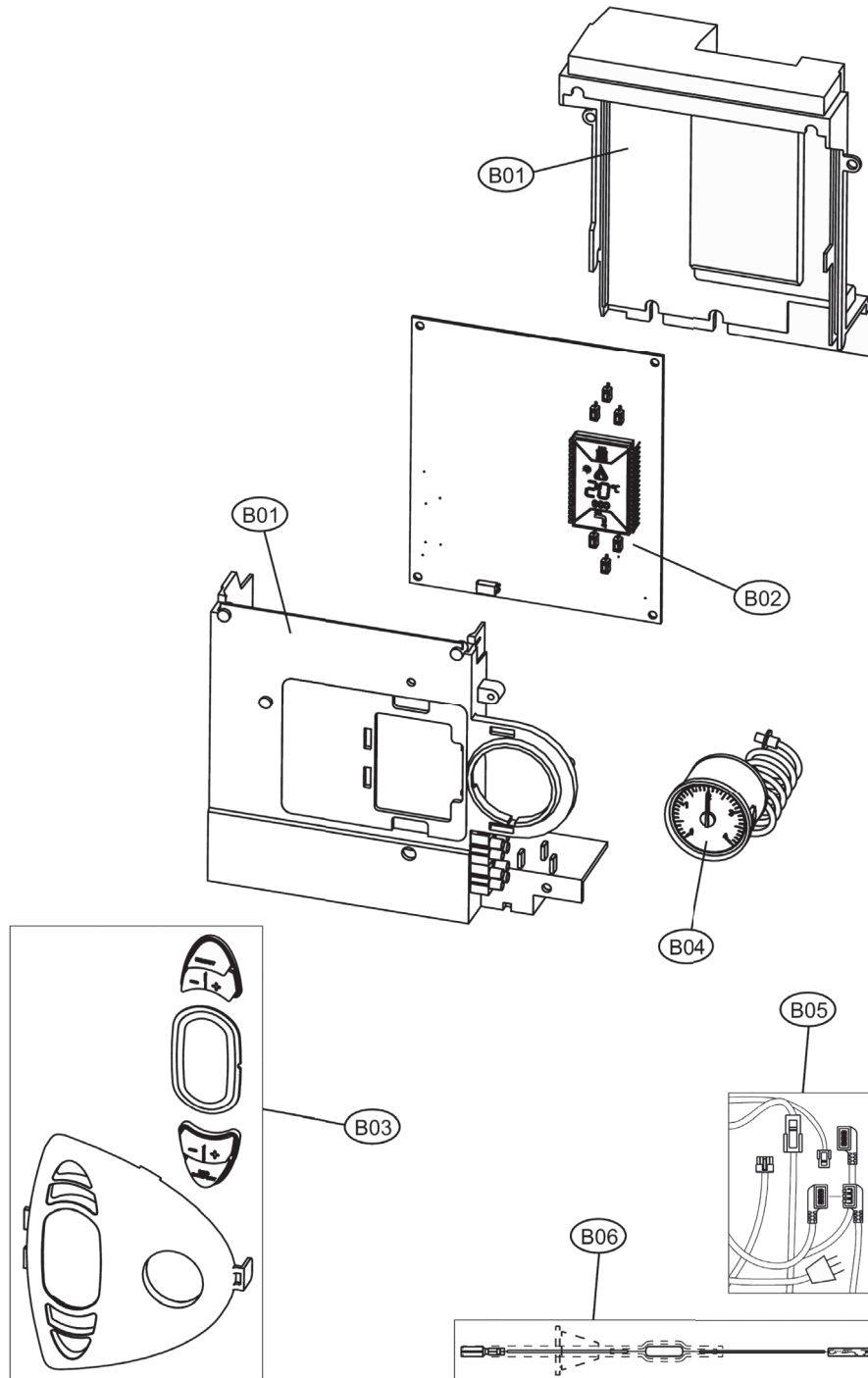

KEY	Part Number	Description	Qty
B01	FE3980C200	KIT CONTROL BOX	1
B02	FE3980B850	KIT CONTROL BOARD DBM34	2
B03	FE3980C210	KIT FRONT COVER "CTR"	1
B04	FE3980B840	KIT PRESS.TEMP.GAUGE	1
B05	FE3980C860	KIT WIRING	1
B06	FE3980C220	KIT MONO CABLE EL.	1

REPAIR PARTS LIST - CHB-100

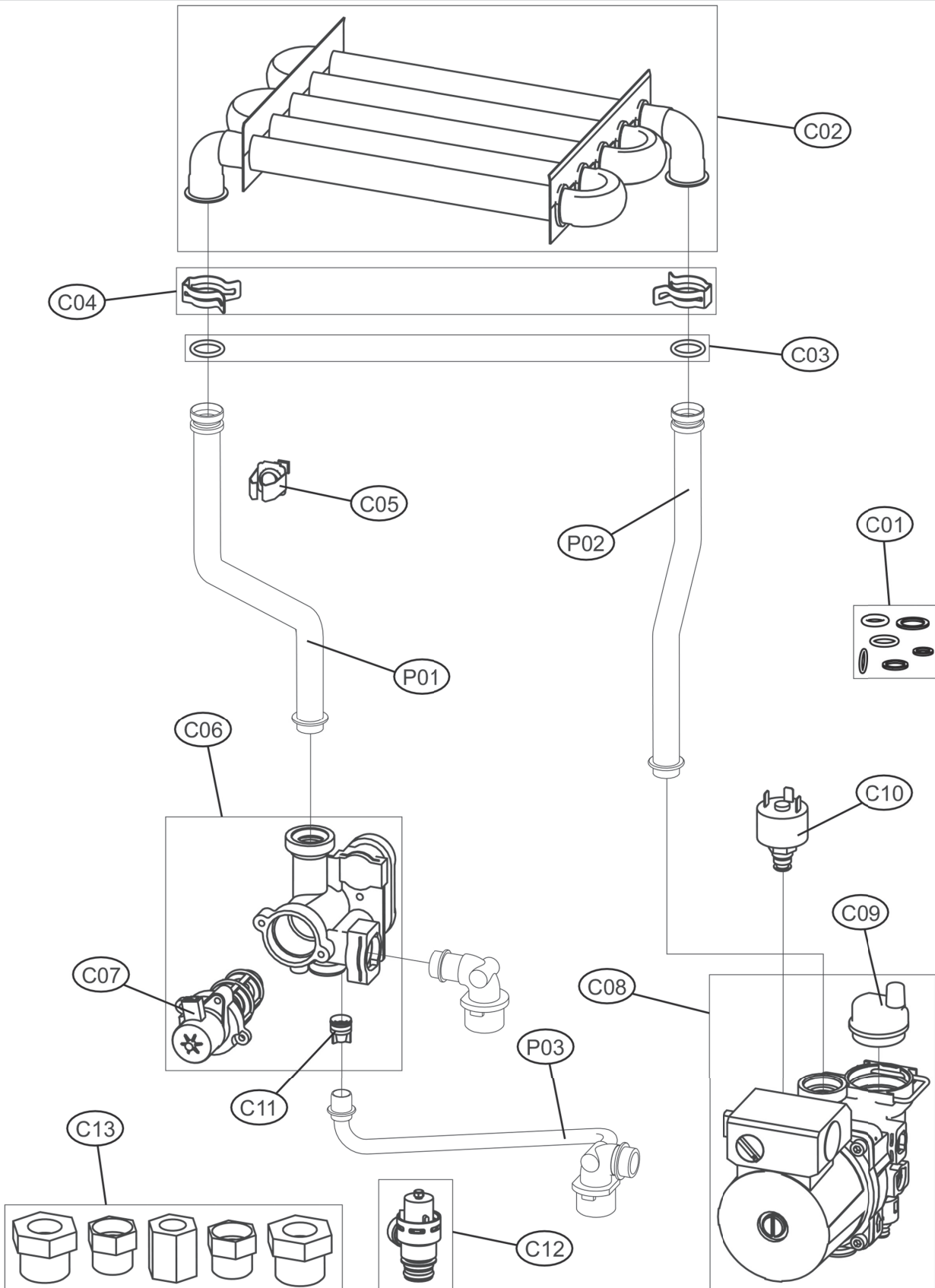

REPAIR PARTS LIST - CHB-100

KEY	Part Number	Description	Qty
C01	FE3980B870	KIT GASKETS SET	10
C02	FE3980C230	MONO HEAT EXCHANGER	1
C03	FE3980C010	KIT GASKET	10
C04	FE3980C020	KIT CLIP D18	2
C05	FE3980C040	TEMP SENSOR DP	1
C06	FE3980C050	KIT 3-WAY VALVE	1
C07	FE3980C060	KIT MOTOR 3-WAY VALVE TP	1
C08	FE3980B890	KIT PUMP FX3-FP	1
C09	FE3980B900	KIT AIR SEPARATOR	5
C10	FE3980C070	KIT WATER PRESSURE SWITCH	1
C11	FE3980C080	KIT X10 N/R BYPASS VALVE	1
C12	FE3980B910	KIT 3/4" SAFETY VALVE	1
C13	FE3980B920	KIT NPT ADAPTERS	1
P01	FE34226300	CH FLOW PIPE	1
P02	FE34225470	CH RETURN PIPE	1
P03	FE3841B170	BYPASS PIPE	1

REPAIR PARTS LIST - CHB-100

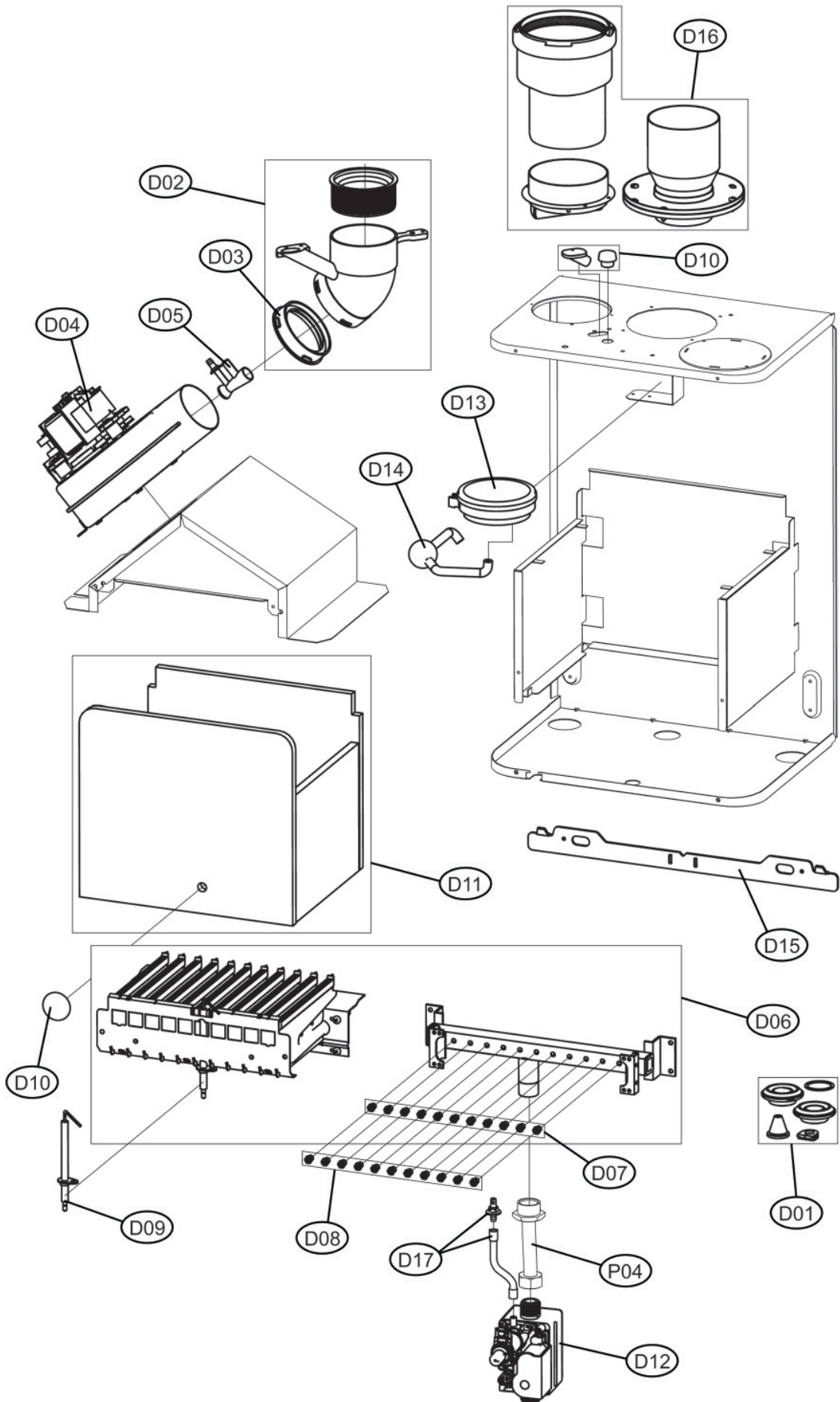

REPAIR PARTS LIST - CHB-100

KEY	Part Number	Description	Qty
D01	FE3980B930	KIT GASKETS SET	1
D02	FE3980C160	KIT FLUE GASES OUTLET BEND	1
D03	FE3980C100	FAN GASKET	1
D04	FE3980C250	KIT FAN	2
D05	FE3980C090	PRESSURE TEST POINT "VENTURI"	1
D06	FE3980C260	KIT BURNER 11 R.m.	1
D07	FE3980C280	KIT 11 INJECTOR 1.35mm NG	1
D08	FE3980C300	KIT 11 INJECTOR 0.85mm LP	2
D09	FE3980C120	IGNITION ELECTRODE	17
D10	FE3980C180	KIT PLUGS CASING	17
D11	FE3980C310	KIT COMBUSTION CHAMBER INSULATION SR.AEO4	1
D12	FE3980B960	GAS VALVE VGU 54S	1
D13	FE3980C170	PRESSURE TRANSDUCER	1
D14	FE3980C190	COUPLING CONDENSATION	1
D15	FE3980B970	WALL MOUNT BRACKET	1
D16	FE3980B980	KIT VENT. ADAPTERS FM	1
D17	FE3980D800	KIT AIR PRESSURE TEST POINT US (35101150)	1
P04	FE3841L460	GAS PIPE	1

REPAIR PARTS LIST - CHB-130

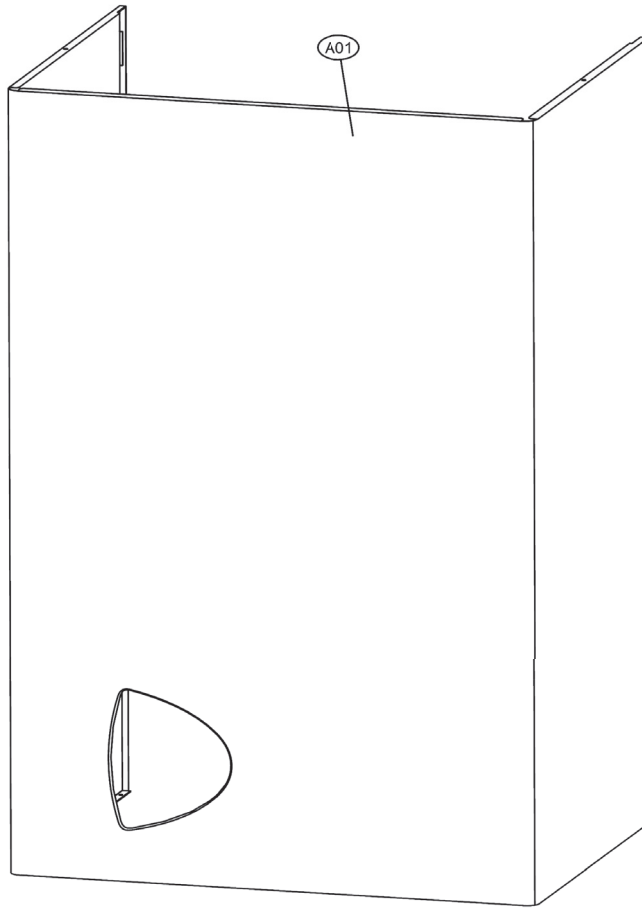

KEY	Part Number	Description	Qty
A01	FE3980B830	CASING "CTR"	1

REPAIR PARTS LIST - CHB-130

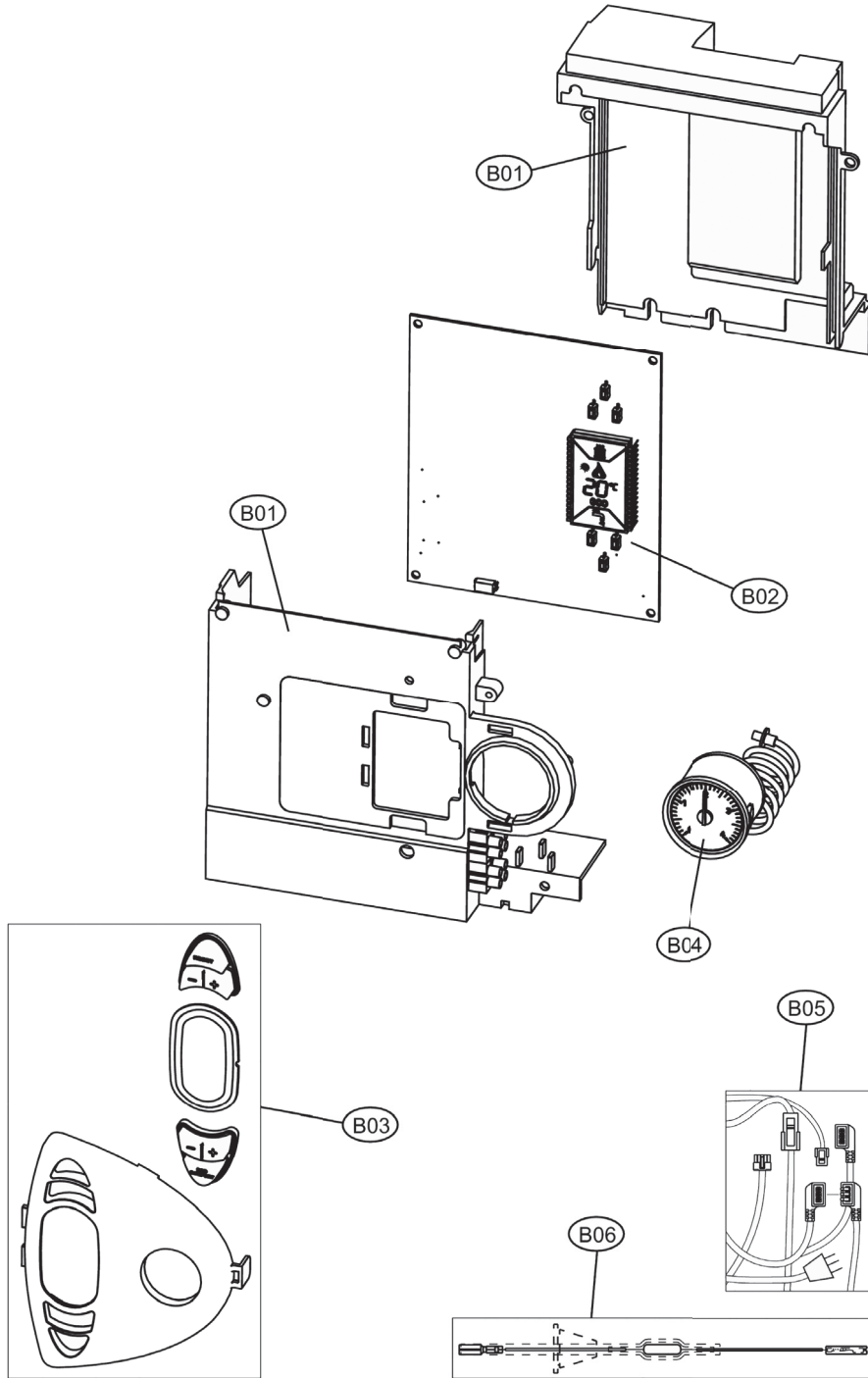

KEY	Part Number	Description	Qty
B01	FE3980C200	KIT CONTROL BOX	1
B02	FE3980B850	KIT CONTROL BOARD DBM34	2
B03	FE3980C210	KIT FRONT COVER "CTR"	1
B04	FE3980B840	KIT PRESS.TEMP.GAUGE	1
B05	FE3980B860	KIT WIRING	1
B06	FE3980C220	KIT MONO CABLE EL.	1

REPAIR PARTS LIST - CHB-130

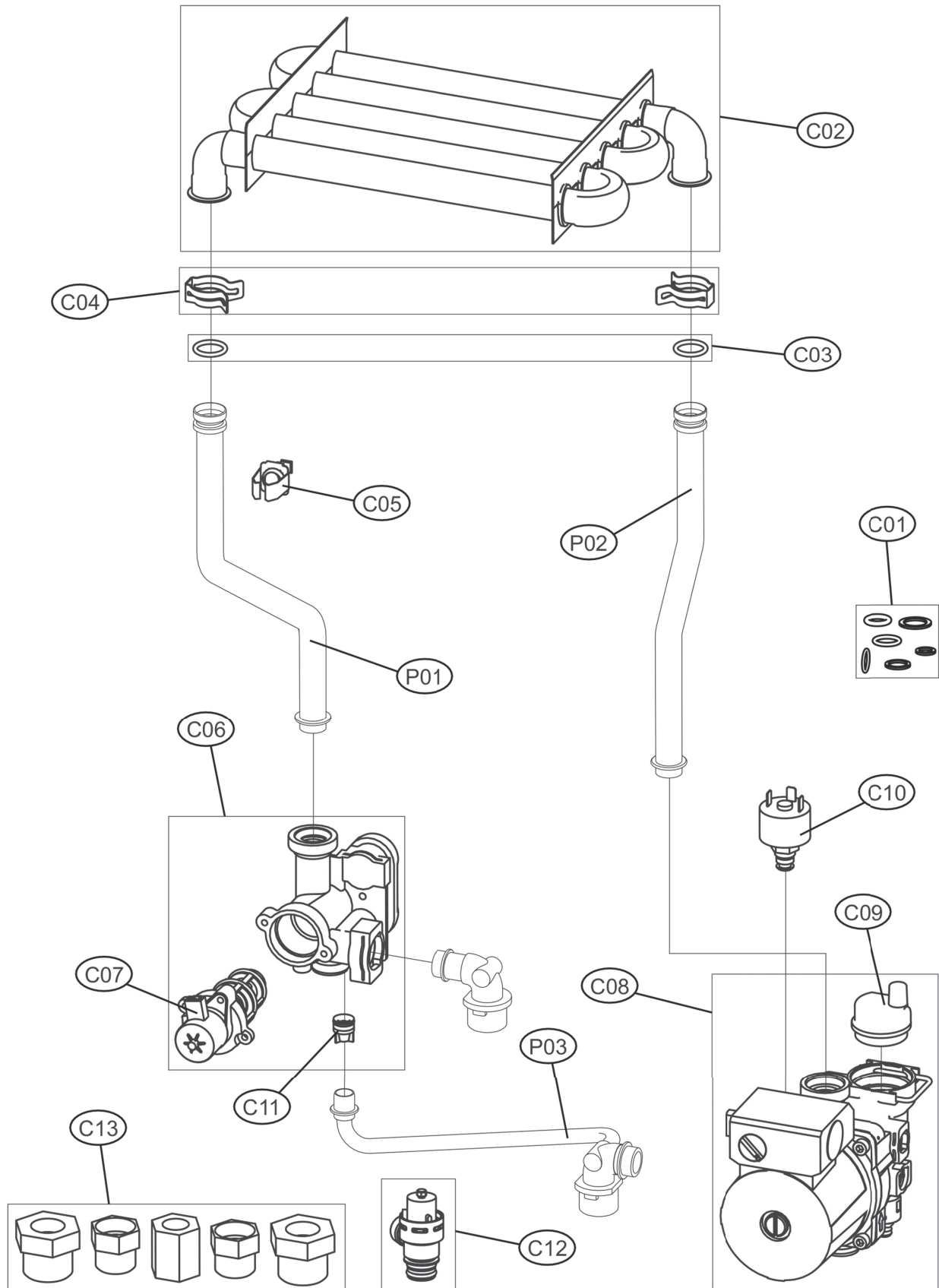

REPAIR PARTS LIST - CHB-130

KEY	Part Number	Description	Qty
C01	FE3980B870	KIT GASKETS SET	10
C02	FE3980B880	KIT MONO HEAT EXCHANGER	1
C03	FE3980C010	KIT 20 GASKET	10
C04	FE3980C020	KIT 10 CLIP D18	2
C05	FE3980C040	TEMP SENSOR DP	1
C06	FE3980C050	KIT 3-WAY VALVE	1
C07	FE3980C060	MOTOR 3-WAY VALVE TP	1
C08	FE3980B890	PUMP FX3-FP	1
C09	FE3980B900	KIT AIR SEPARATOR	5
C10	FE3980C070	WATER PRESSURE SWITCH	1
C11	FE3980C080	KIT X10 N/R BYPASS VALVE	1
C12	FE3980B910	KIT 3/4" SAFETY VALVE	1
C13	FE3980B920	KIT NPT ADAPTERS	1
P01	FE34226280	CH FLOW PIPE	1
P02	FE34202130	CH RETURN PIPE	1
P03	FE3841B170	BYPASS PIPE	1

REPAIR PARTS LIST - CHB-130

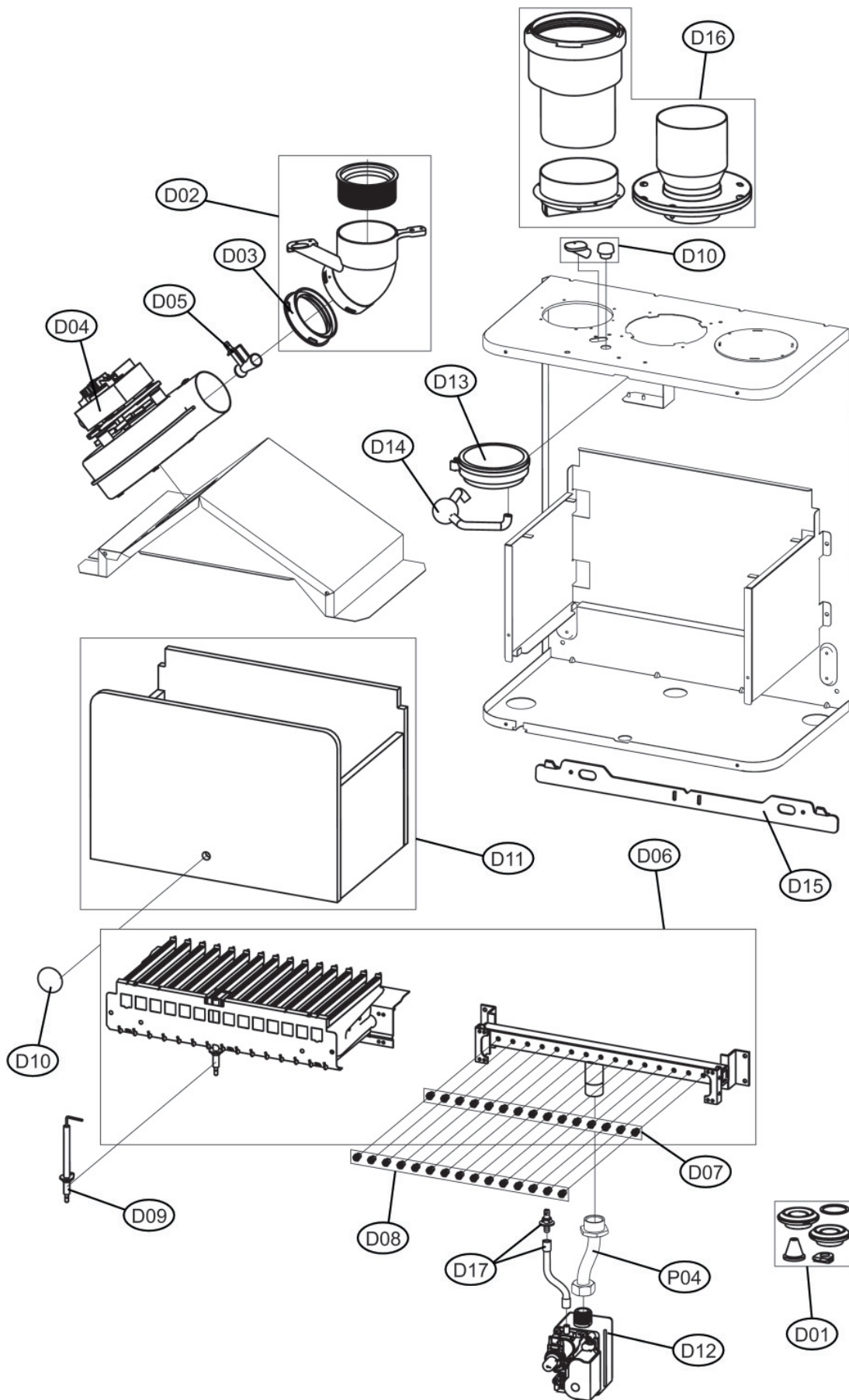

REPAIR PARTS LIST - CHB-130

KEY	Part Number	Description	Qty
D01	FE3980B930	KIT GASKETS SET	1
D02	FE3980C160	KIT FLUE GASES OUTLET BEND	1
D03	FE3980C100	KIT FAN GASKET	1
D04	FE3980B940	KIT FAN	2
D05	FE3980C090	KIT PRESSURE TEST POINT "VENTURI"	1
D06	FE3980C270	KIT BURNER 15 R.m.	1
D07	FE3980C290	KIT 15 INJECTOR 1.35mm NG	1
D08	FE3980B950	KIT 15 INJECTOR 0.85mm LP	2
D09	FE3980C120	KIT IGNITION ELECTRODE	17
D10	FE3980C180	KIT PLUGS CASING	17
D11	FE3980C320	COMBUSTION CHAMBER INSULATION SR.AEO7	1
D12	FE3980B960	KIT GAS VALVE VGU 54S	1
D13	FE3980C170	KIT PRESSURE TRANSDUCER	1
D14	FE3980C190	KIT COUPLING CONDENSATION	1
D15	FE3980B970	WALL MOUNT BRACKET	1
D16	FE3980B980	KIT VENT.ADAPTERS FM	1
D17	FE3980D800	KIT AIR PRESSURE TEST POINT US (35101150)	1
P04	FE3841L370	GAS PIPE	1



ECR International, Inc
2201 Dwyer Avenue, Utica NY 13501

web site: www.ecrinternational.com