

# INSTALLATION INSTRUCTIONS

These instructions must be affixed on or adjacent to the boiler

## Dunkirk

# WPSB SERIES

## Gas-Fired Hot-Water Boilers

These Gas-Fired Water Boilers are low pressure, sectional cast iron boilers Designed Certified by C.S.A. (Canadian Standards Association) for use with Natural and Propane Gases. They are constructed and hydrostatically tested for a maximum working pressure of 50 psi (pounds per square inch) in accordance with A.S.M.E. (American Society of Mechanical Engineers) Boiler and Pressure Vessel Code Section IV Standards for cast iron heating boilers.



**MODEL WPVSB**  
Continuous Pilot

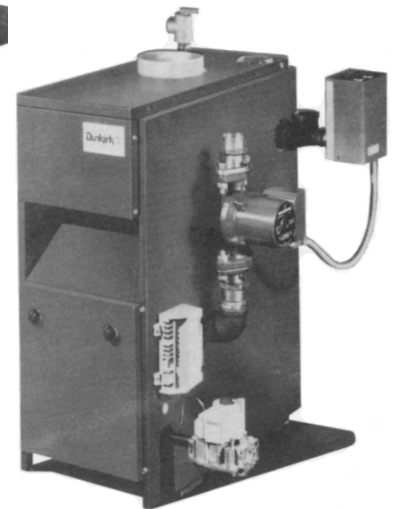

**MODEL WPSB**  
Electronic  
Intermittent Ignition

**Warning:** Improper installation, adjustment, alteration, service or maintenance can cause injury or property damage. Refer to this manual. For assistance or additional information consult a qualified installer, service agency or the gas supplier

## DUNKIRK BOILERS

DUNKIRK, NEW YORK 14084 • AREA CODE 716 366-5500

*MEMBER: The Hydronics Institute*

# Boiler Ratings and Capacities

FIG. 1

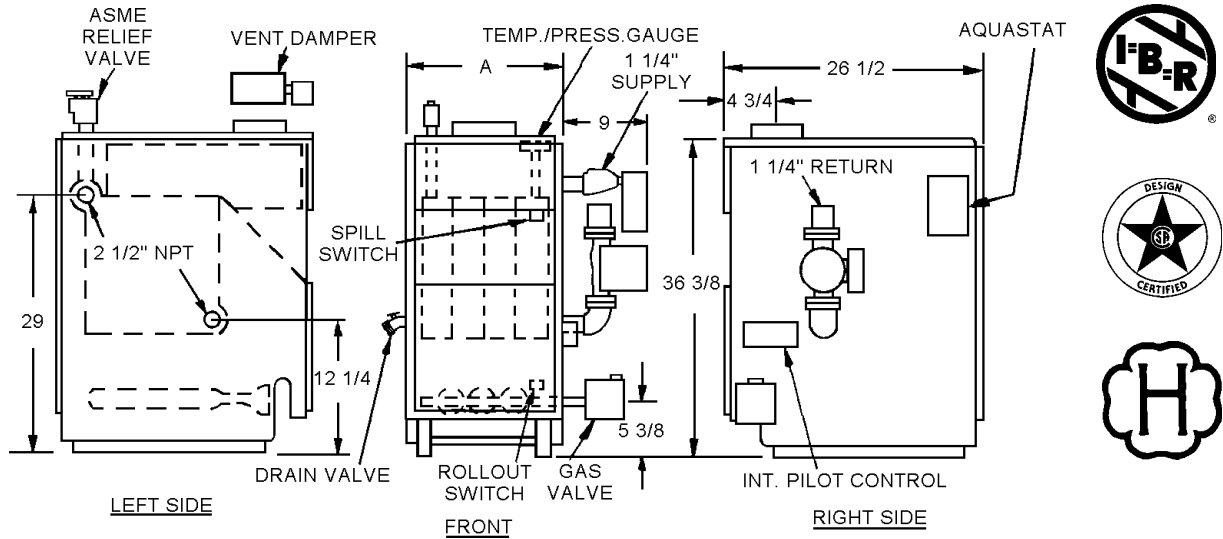

## GAS-FIRED HOT-WATER BOILERS

BOILER MODEL NUMBER		NO. OF SECTIONS	†NATURAL GAS			†PROPANE GAS			DIMENSIONS(Inch.)		AFUE	
INTERMITTENT IGNITION WITH VENT DAMPER	STANDING PILOT WITH VENT DAMPER		AGA INPUT *MBH	HEATING CAPACITY *MBH	NET I=B=R RATING	AGA INPUT	HEATING CAPACITY *MBH	NET I=B=R RATING	FLUE DIAMETER	"A" WIDTH	INTERMITTENT IGNITION WITH VENT DAMPER	STANDING PILOT WITH VENT DAMPER
WPSB-3D	WPVSB-3D	3	75	63	55	70	59	51	5	11¼	84.0	82.6
WPSB-4D	WPVSB-4D	4	112.5	94	82	105	88	77	6	14½	84.0	82.7
WPSB-5D	WPVSB-5D	5	150	126	110	140	118	103	6	17¾	84.1	82.8
WPSB-6D	WPVSB-6D	6	187.5	157	137	175	147	128	7	21	84.1	82.9
WPSB-7D	WPVSB-7D	7	225	188	163	210	176	153	7	24¼	84.0	83.0
WPSB-8D	WPVSB-8D	8	262.5	220	191	245	206	179	7	27½	83.9	83.1
WPSB-9D	WPVSB-9D	9	299	251	218	280	235	204	7	30¾	83.7	83.2

\* MBH = 1,000 Btuh = British Thermal Unit Per Hour

\*\*Add 5½" to height for vent Damper.

†For altitudes above 2,000 ft. rating should be reduced at the rate of 4% for each 1,000 ft. above sea level.

Heating Capacity is based on D.O.E. (Department of Energy) test procedure.

The Ratings marked "Net 1=B=R Ratings" indicate the amount of remaining heat input that can be used to heat the radiation or terminal units. The Net 1=B=R Ratings shown are based on an allowance of 1.15 in accordance with the factors shown on the 1=B=R Standard as published by The Hydronics Institute.

Selection of boiler size should be based upon "Net 1=B=R Rating" being equal to or greater than the calculated heat loss of the building.

The manufacturer should be consulted before selecting a boiler for installations having unusual piping and pickup requirements.

These boilers must stand on a non-combustible floor. If installed on a combustible floor, use Combustible Floor Base

Number 42135-1 or 146-14-031 (3-6 section boilers) or 42135-2 or 146-14-032 (7-9 section boilers).

### BOILERS FOR USE AT HIGH ALTITUDE

This boiler is factory equipped for use at altitudes of 0-2,000 feet above sea level. For use at altitudes above 2,000 feet above sea level, the input ratings are reduced by a change in main burner orifice size.

For altitudes above 2,000 feet above sea level, input ratings should be reduced at the rate of 4% for each 1,000 feet above sea level. Consult the *National Fuel Gas Code* (NFPA54/ANSI Z223.1-latest edition), or the manufacturer for correct orifice sizing information. High altitude orifices are available from the boiler manufacturer.

# Before You Start

Check to be sure you have the right size boiler before starting the installation. See rating and capacity table on previous page. Also be sure the new boiler is or the type of gas you are using. Check the rating plate on the right side of the boiler.

You must see that the boiler is supplied with the correct type of gas, fresh air for combustion, and a suitable electrical supply. Also, the boiler must be connected to a suitable venting system and an adequate piping system. Finally, a thermostat, properly located, is needed for control of the heating system. If you have any doubts as to the various requirements, check with local authorities and obtain professional help where needed. Take the time to complete all of the steps for SAFE and PROPER operation of the heating system.

If this boiler is installed in a building under construction, special care must be taken to insure a clean combustion air supply during the construction process. Airborne particulates such as from drywall dust and from fiberglass insulation can clog the burner ports and cause incomplete combustion and sooting.

Where required by the authority having jurisdiction, the installation must conform to American Society of Mechanical Engineers Safety Code for Controls and Safety Devices for Automatically Fired Boilers, No. CSD-1.

The installation must conform to the requirements of the authority having jurisdiction or, in the absence of such requirements, to the National Fuel Gas Code, ANSI Z223.1- latest revision.

**KEEP BOILER AREA CLEAN AND FREE FROM COMBUSTIBLE MATERIALS, GASOLINE AND OTHER FLAMMABLE VAPORS AND LIQUIDS**

# Locating the Boiler

1. Select level location as centralized with piping system, and as near chimney, as possible.
2. Place crated boiler at selected location, remove crate by pulling crate sides from top and bottom boards. Combustible floors: When boiler is to be installed on a combustible floor, a Special Base Plate must be used - 146-14-031 (2-6 Section) or 146-14-032 (7-9 Section). This boiler must not be installed on carpeting.
3. Boiler is to be level. Metal shims may be used under base legs for final leveling.
4. **Accessibility clearances must take precedence over fire protection clearances.** An 18-inch clearance should be maintained on any side where passage is required to access another side for cleaning, servicing, inspection or replacement of any part that may need attention. An 18-inch clearance is recommended on the control side for servicing.  
Figure 2 shows minimum clearances to combustible construction. Rooms that are large in comparison with the size of the boiler are defined as rooms having a volume equal to or greater than 16 times the volume of the boiler. Where the actual ceiling height of a room is greater than 8', the volume of a room shall be figured on the basis of a ceiling height of 8'. Determination of room size should be based on the total volume of all gas fired equipment installed in the room. Consult section 6.3.1 of the National Fuel Gas Code for further information, including approved methods for reducing clearances in large rooms.
5. Equipment shall be installed in a location in which the facilities for ventilation permit satisfactory combustion of gas, proper venting, and maintenance of ambient temperature at safe limits under normal conditions of use. Equipment shall be located so as not to interfere

- with proper circulation of air. When normal infiltration does not provide the necessary air, outside air shall be introduced (See Page 4 - "Fresh Air for Combustion").
6. Advise owner to keep air passages free of obstructions. Ventilating and combustion air must enter boiler room without restrictions.
7. The boiler shall be installed such that the automatic gas ignition system components are protected from water (dripping, spraying, rain, etc.) during appliance operation and service (condensate trap, control replacement, etc.).

**FIG. 2 - MINIMUM CLEARANCE DIMENSIONS**

	Alcove, or Room Not Large In Comparison With Boiler	Room Large In Comparison With Boiler
Top	6"	6"
Rear	6"	6"
Control Side	7"	6"
Opposite Side	6"	6"
Front	18"	18"
Flue/Vent Connector	6"	6"
Near Boiler Piping	1"	1"

Boiler Size	Boiler Volume (Cu. Ft.)	Minimum Room Volume Required To Be Large Room (Cu.Ft.)*
3 sect.	6.3	100.4
4 sect.	8.1	129.4
5 sect.	9.9	158.4
6 sect.	11.7	187.4
7 sect.	13.5	216.4
8 sect.	15.3	245.4
9 sect.	17.2	274.5

# Fresh Air for Combustion

**Provision for combustion and ventilation air must be in accordance with Section 5.3, Air for Combustion and Ventilation, of the National Fuel Gas Code, ANSI Z223.1-latest revision, or applicable provisions of the local building codes.**

## WARNING

Be sure to provide enough fresh air for combustion. Enough air insures proper combustion and **assures that no hazard will develop due to the lack of oxygen.**

You must provide for enough fresh air to assure proper combustion. The fire in the boiler uses oxygen. It must have a continuous supply. The air in a house contains only enough oxygen to supply the burner for a short time. Outside air must enter the house to replace that used by the burner. Study following examples 1 and 2 to determine your fresh air requirements.

### EXAMPLE 1: Boiler Located in Unconfined Space

An unconfined space is defined as a space whose volume is not less than 50 cubic feet per 1,000 Btu per hour of the total input rating of all appliances installed in that space.

If your boiler is in an open area (unpartitioned basement) in a conventional house, the air that leaks through the cracks around doors and windows will usually be adequate to provide air for combustion. The doors should not fit tightly. Do not caulk the cracks around the windows.

Equipment located in buildings of unusually tight construction shall be provided with air for combustion, ventilation, and dilution of flue gases using the methods described in example 2B or shall be specially engineered. The authority having jurisdiction must approve specially engineered installations.

### EXAMPLE 2: Boiler Located in Confined Space

**A. All Air from Inside the Building:** The confined space shall be provided with two permanent openings communicating directly with an additional room(s) of sufficient volume so that the combined volume of all spaces meets the criteria for an unconfined space. The total input of all gas utilization equipment installed in the combined space shall be considered in making this determination. Each opening shall have a minimum free area of one square inch per 1,000 Btu per hour of the total input rating of all gas utilization equipment in the confined space, but not less than 100 square inches. One opening shall be within 12 inches of the top and one within 12 inches of the bottom of the enclosure. The minimum dimension of air openings shall not be less than 3 inches.

**B. All Air from Outdoors:** The confined space shall communicate with the outdoors in accordance with methods 1 or 2. The minimum dimension of air openings shall not be less than 3 in. Where ducts are used, they shall be of the same cross-sectional area as the free area of the openings to which they connect.

1. Two permanent openings, one commencing within 12 inches of the top and one commencing within 12 inches of the bottom, of the enclosure shall be provided. The openings shall communicate directly, or by the ducts, with the outdoors or spaces (crawl or attic) that freely communicate with the outdoors.
  - a) Where directly communicating with the outdoors or where communicating to the outdoors through vertical ducts. Each opening shall have a minimum free area of 1 sq. in. per 4000 Btu per hour of total input rating of all equipment in the enclosure. (See Figure 3B)
  - b) Where communicating with the outdoors through horizontal ducts. Each opening shall have a minimum free area of 1 sq. in. per 2000 Btu per hour of total input rating of all equipment in the enclosure. (See Figure 38.)

## NOTE

If you use a fireplace or a kitchen or bathroom exhaust fan, you should install an outside air intake. These devices will rob the boiler and water heater of combustion air.

2. One permanent opening commencing with 12 inches of the top of the enclosure, shall be permitted where the equipment has clearance of at least 1 inch from the sides and back and 6 inches from the front of the appliance. The opening shall directly communicate with the outdoors or shall communicate through a vertical or horizontal duct to the outdoors or spaces (crawl or attic) that freely communicate with the outdoor, and shall have a minimum free area of:
  - a) 1 sq. inch per 3000 Btu per hour of the total input of all equipment located in the enclosure ( See Figure 4), and
  - b) Not less than the sum of the areas of all vent connectors in the confined space.

**Figure 3A - FRESH AIR DUCT CAPACITIES (Btuh)**

1 Square Inch per 4,000 Btuh

	100% Free Area	75% Free Area	25% Free Area
Fresh Air Duct Size	¼" Wire Mesh	Metal Louvers	Wood Louvers
3" x 12"	144,000	108,000	36,000
8" x 8"	256,000	192,000	64,000
8" 12"	384,000	288,000	96,000
8½" x 16"	512,000	384,000	128,000

**Figure 3B - FRESH AIR DUCT CAPACITIES (Btuh)**

1 Square Inch per 2,000 Btuh

	100% Free Area	75% Free Area	25% Free Area
Fresh Air Duct Size	¼" Wire Mesh	Metal Louvers	Wood Louvers
3" x 12"	72,000	54,000	18,000
8" x 8"	128,000	96,000	32,000
8" 12"	192,000	144,000	48,000
8½" x 16"	256,000	192,000	64,000

**Figure 4 - FRESH AIR DUCT CAPACITIES (Btuh)**

1 Square Inch per 3,000 Btuh

	100% Free Area	75% Free Area	25% Free Area
Fresh Air Duct Size	¼" Wire Mesh	Metal Louvers	Wood Louvers
3" x 12"	108,000	81,000	27,000
8" x 8"	192,000	144,000	48,000
8" 12"	288,000	216,000	72,000
8½" x 16"	384,000	288,000	96,000

# Installation - System Piping

1. Place boiler in the selected location (as near chimney as possible.) Your boiler is shipped assembled. You need only to install the Relief Valve and a drain line to carry any water or steam to a drain.
2. Install Relief Valve into the 3/4" pipe on the top of the boiler. See Figure 5. Use 3/4" Pipe and an elbow (not furnished) to carry the water or steam to a nearby drain. Do not connect directly to a drain but leave an air gap. No shutoff of any description shall be placed between the safety relief valve and the boiler, or on discharge pipes between such safety valves and the atmosphere. Installation of the safety relief valve shall conform to the requirements of the ANSI/ASME Boiler and Pressure Vessel Code, Section IV. The manufacturer is not responsible for any water damage. Install Drain Valve in lower left side of boiler as marked.
3. Connect Supply and Return Lines to boiler. The connections may require certain additional fittings and parts, as shown on diagram (Figs. 5 and 6).
4. This boiler is equipped with 1 1/4" supply and return connections on both the left and right sides of the boiler. In connecting the cold water supply to the water inlet valve, make sure that a clean water supply is available. When the water supply is from a well or pump, a sand strainer should be installed at the pump.

A hot water boiler installed above radiation level must be equipped with a low water cutoff device. A periodic inspection is necessary, as is flushing of float type devices, per manufacturers specific instruction.

## FOR USE WITH COOLING UNITS

- A. This boiler, when used in connection with chilled water systems, must be installed so that the chilled water is piped in parallel with the heating boiler. Appropriate valves must be used to prevent the chilled water from entering the heating boiler (Fig. 6).
- B. When this boiler is connected to heating coils located in air handling units where they may be exposed to refrigerated air circulation, the piping system shall be equipped with flow control valves or other automatic means to prevent gravity circulation of the boiler water during the cooling cycle.

## LOW WATER TEMPERATURE AND LARGE WATER CONTENT SYSTEM

Significant condensation may form in this boiler and/or the venting system if the boiler is operated for a long period of time with return temperatures of less than 120° F.

This condensation is corrosive and can eventually cause severe damage to the boiler and venting system. The minimum design return water temperature to prevent condensation in the boiler and venting is 120°F. The minimum high limit setting is 140°F.

1. If the boiler is to be used in a heating system where design water temperatures below 140°F are desired (e.g. radiant floor heating), a 4-way mixing valve or suitable alternative is required to prevent low temperature return water from entering the boiler. Follow the mixing valve manufacturer's instructions.
2. If the boiler is to be connected to a system having a large water content (such as a former gravity system), install a system bypass as shown in Figures 7 and 8.
3. If a boiler water reset control is used to operate the boiler, the minimum reset supply water temperature setpoint must be at least 140°F, unless a mixing valve is used as in (1) above.

**FIG. 5 - TYPICAL HOT WATER PIPING**

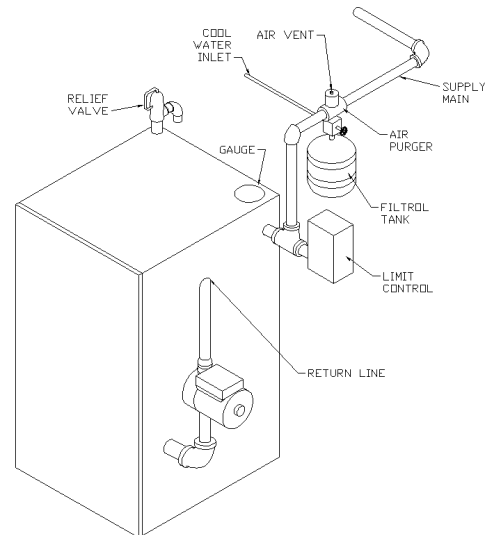

**FIG. 6 - CHILLED WATER PIPING**

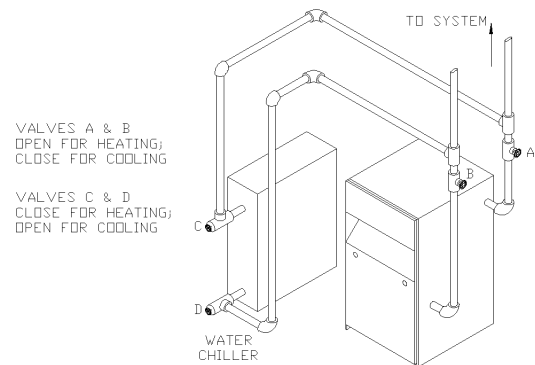

**FIG. 7  
BYPASS PIPING - CIRCULATOR ON SUPPLY**

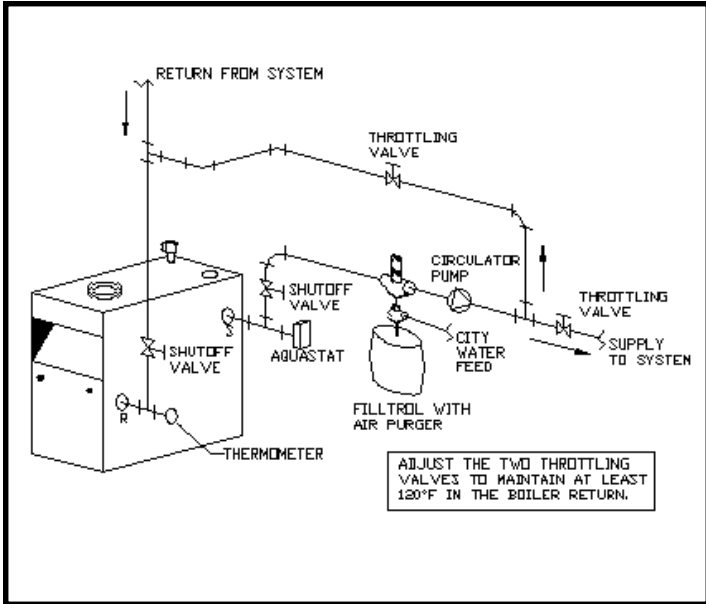

**FIG. 8  
BYPASS PIPING - CIRCULATOR ON RETURN**

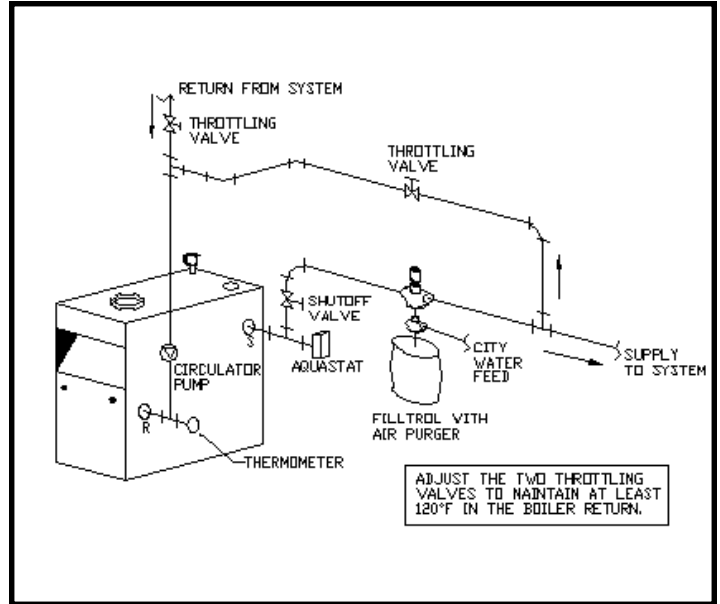

**BYPASS PIPING REQUIRED FOR HIGH MASS (LARGE WATER CONTENT) SYSTEMS**

## Chimney and Vent Pipe Connection

**For boilers for connection to gas vents or chimneys, vent installations shall be in accordance with Part 7, Venting of Equipment, of the National Fuel Gas Code, ANSI Z223.1 latest revision and applicable provisions of the local building codes.**

### CHECK YOUR CHIMNEY

This is a very important part of your heating system. It must be clean, the right size, properly constructed and in GOOD CONDITION. No boiler can function properly with a bad chimney.

### CHIMNEY SIZING

Chimney sizing, and all other aspects of the vent installation must be in accordance with Part 7 and Part 11 of the National Fuel Gas Code, ANSI Z223 1- latest revision, and applicable provisions of the local building codes.

This is a high efficiency boiler with a low stack temperature. The following recommendations are in addition to the requirements of the National Fuel Gas Code.

1. Type B double wall vent pipe is recommended for the vent connector. Single wall vent connectors should not be used unless both of the following condition are true:
  - a) Except for a basement, the boiler is not installed in an unheated space.
  - b) The total horizontal portion of the vent connector, not including elbows is less than 5 feet in length.
2. Outside chimneys (i.e. chimneys exposed to the outdoors below the roof line) should not be use unless they are:
  - a) enclosed in a chase, or

- b) lined with type B vent pipe, or listed flexible vent liner, or other certified chimney lining system.
3. Where possible it is recommended to common vent the boiler and water heater.
4. For multiple boiler installations, consult the boiler manufacturer for venting recommendations.

### CONNECTING THE VENT DAMPER AND VENT CONNECTOR

Refer to Fig. 1 the size and location of the vent (flue opening).

**IMPORTANT** - The damper blade on the furnished vent damper has a 1/2 square inch hole (approximately 3/4" diameter). On boilers equipped with standing pilot, the hole must be left open. On boilers equipped with intermittent ignition, the hole should be plugged by using the plug supplied with the vent damper.

1. Position furnished vent damper on top of flue outlet collar. Fasten damper securely to flue outlet collar with sheet metal screws. Make sure damper blade has clearance to operate inside of diverter.

### As An Option (U.S.A. Only)

The damper may be installed in any horizontal or vertical position, closer to the flue outlet collar preferred. Follow the diagrams - Figures 9, 10 and 11.

2. Install the vent damper to service only the single boiler for which it is intended. The damper position indicator shall be in a visible location following installation. Locate the damper so that it is accessible for servicing.
3. The damper must be in the open position when appliance main burners are operating.
4. The boiler is equipped with a factory wired harness that plugs into the vent damper.
5. Slope pipe up from boiler to chimney not less than 1/4" per foot.
6. Run pipe as directly as possible with as few elbows as possible.
7. Do not connect to fireplace flue.
8. End of vent pipe must be flush with inside face of chimney flue. Use a sealed-in thimble for the chimney connection.

The sections of vent pipe should be fastened with sheet metal screws to make the piping rigid. Horizontal portions of the vent system must be supported to prevent sagging. Use stovepipe wires every 5' to support the pipe from above. If the vent pipe must go through a crawl space, double wall vent pipe should be used. Where vent pipe passes through a combustible wall or partition, use a ventilated metal thimble. The thimble should be 4 inches larger in diameter than the vent pipe.

### **MINIMUM VENT PIPE CLEARANCE**

Wood and other combustible materials must not be closer than 6" from any surface of single wall metal vent pipe. Listed Type B vent pipe or other listed venting systems shall be installed in accordance with their listing.

### **REMOVING EXISTING BOILER FROM COMMON VENTING SYSTEM**

When an existing boiler is removed from a common venting system, the common venting system is likely to be too large for proper venting of the appliances remaining connected to it.

At the time of removal of an existing boiler, the following steps shall be followed with each appliance remaining connected to the common venting system placed in operation, while the other appliances remaining connected to the common venting system are not in operation.

1. Seal any unused openings in the common venting system.
2. Visually inspect the venting system for proper size and horizontal pitch and determine there is no blockage or restriction, leakage, corrosion and other deficiencies which could cause an unsafe condition.
3. Insofar as is practical, close all building doors and windows and all doors between the space in which the appliances remaining connected to the common venting system are located and other spaces of the building. Turn on clothes dryers and any appliance not connected to the common venting system. Turn on any exhaust fans, such as range hoods and bathroom exhausts, so they will operate at maximum speed. Do not operate a summer exhaust fan. Close fireplace dampers.
4. Place in operation the appliance being inspected. Follow the lighting instructions. Adjust thermostat so appliance will operate continuously.
5. Test for spillage at the draft hood relief opening after 5 minutes of main burner operation. Use the flame of a match or candle, or smoke from a cigarette, cigar or pipe.
6. After it has been determined that each appliance remaining connected to the common venting system properly vents when tested as outlined above, return doors windows, exhaust fans, fireplace dampers and any other gas-burning appliance to their previous conditions of use.
7. Any improper operation of the common venting system should be corrected so the installation conforms with the National Fuel Gas Code, ANSI Z223.1-latest revision. When resizing any portion of the common venting system, the common venting system should be resized to approach the minimum size as determined using the appropriate tables in Part 11 in the National Fuel Gas Code, ANSI Z223.1-latest revision.

**For boilers for connection to gas vents or chimneys, vent installations shall be in accordance with Part 7, Venting of Equipment, of the National Fuel Gas Code, ANSI Z223.1-latest revision and applicable provisions of the local building codes.**

**Vent connectors serving appliances vented by natural draft shall not be connected into any portion of mechanical draft systems operating under positive pressure.**

# Vent Damper Operation

**FIG. 9**

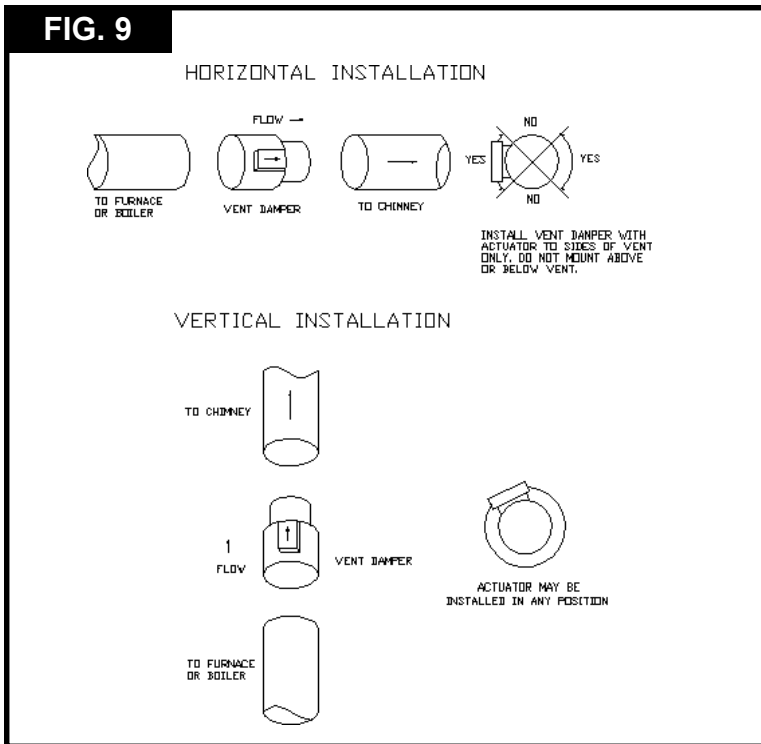

**FIG. 10**

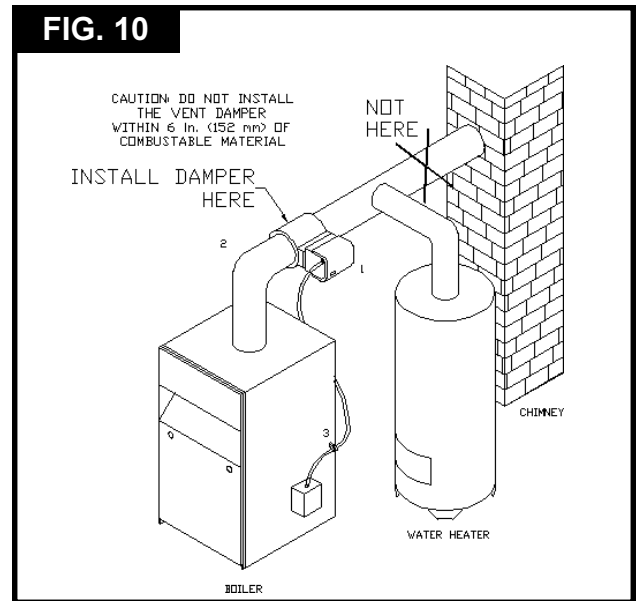

## TYPICAL INSTALLATION FOR THE VENT DAMPER NOTE CAUTION AND FOOTNOTES

1. Install the vent damper to service only the single appliance for which it is intended. If improperly installed, a hazardous condition, such as an explosion or carbon monoxide poisoning, could result.
2. Do not install the vent damper on vent pipe curve.
3. Do not run wires near high temperature surfaces. Use stand-off brackets if necessary.

For safe, efficient operation, the vent damper and all flue product carrying areas of the appliance must be checked annually by you, with particular attention given to deterioration from corrosion or other sources. If you see corrosion or other deterioration, contact your heating contractor for repairs. Check vent damper operation as follows:

1. When the boiler is off, check that the vent damper position indicator points to the closed position, Fig. 11.
2. Turn the thermostat or controller up to call for heat and check the vent damper indicator points to the open position, Fig. 11.
3. Turn the thermostat or controller down again and check that the damper position indicator returns to the closed position.

## MANUAL OPERATION OF THE VENT DAMPER

The vent damper may be placed in the open position to permit burner operation by using the “HOLD DAMPER OPEN” switch, located on the damper controller. The thermostat will control the burner firing as before, while the damper will remain open. **DO NOT** turn damper open manually or motor damage will result. Set switch to “AUTOMATIC OPERATION” to close vent damper during burner off cycle.

For further information, and for a vent damper troubleshooting guide, refer to the manual that was packaged with the vent damper.

**The vent damper must be inspected at least once a year by a trained, experienced service technician. The name of the person who originally installed your vent damper is shown on the installation label.**

**FIG. 11**  
**VENT DAMPER POSITION INDICATOR**

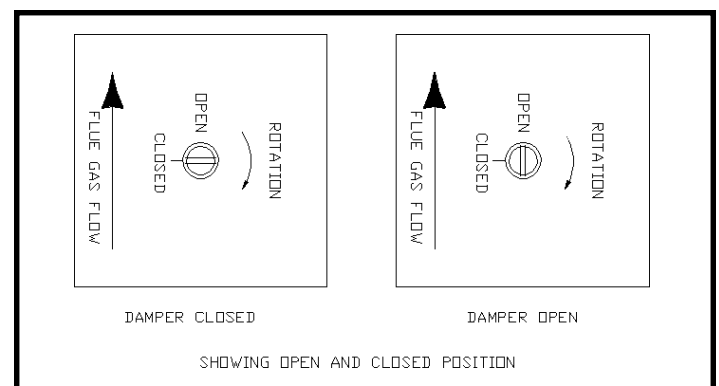



# Gas Supply Piping

## CHECK GAS SUPPLY

The gas pipe to your boiler must be the correct size for the length of the run and for the total BTU per hour input of all gas utilization equipment connected to it. See Fig. 12 for the proper size. Be sure your gas line complies with local codes and gas company requirements.

The boiler and its individual shutoff valve must be disconnected from the gas supply piping system during any pressure testing of that system at test pressures in excess of 1/2 psig (3.5 kPa).

The boiler must be isolated from the gas supply piping system by closing its individual manual shutoff valve during any pressure testing of the gas supply piping system at test pressures equal to or less than 1/2 psig (3.5 kPa).

## CONNECTING THE GAS PIPING

Refer to Fig. 13 for the general layout at the boiler. It shows the basic fittings you will need. The gas line enters the boiler from the right side.

The following rules apply:

1. Use only those piping materials and joining methods listed as acceptable by the authority having jurisdiction, or in the absence of such requirements, by the National Fuel Gas Code, ANSI 2223.1-latest revision. In Canada, follow the CAN/CGA B149.1 and .2 Installation Codes for Gas Burning Appliances and Equipment.
2. Use pipe joint compound suitable for LP gas on male threads only.
3. Use ground joint unions.
4. Install a sediment trap upstream of gas controls.
5. Use two pipe wrenches when making the connection to the gas valve to keep it from turning.
6. Install a manual shut-off valve in vertical pipe about 5 feet above floor.
7. Tighten all joints securely.
8. Propane gas connections should only be made by a licensed propane installer.
9. Two-stage regulation should be used by the propane installer.
10. Propane gas piping should be checked out by the propane installer.

## CHECKING THE GAS PIPING

Upon completion of piping, check immediately for gas leaks. Open the manual shut-off valve. Test for leaks by applying soap suds (or a liquid detergent) to each joint. Bubbles forming indicate a leak. CORRECT EVEN THE SMALLEST LEAK AT ONCE.

### WARNING

Never use a match or open flame to test for leaks.

FIG. 12 - GAS PIPE SIZES

NATURAL GAS				
Length of Pipe - Ft.	Pipe Capacity - BTU Per Hour Input Includes Fittings			
	1/2"	3/4"	1"	1 1/4"
20	92,000	190,000	350,000	625,000
40	63,000	130,000	245,000	445,000
60	50,000	105,000	195,000	365,000

  

PROPANE GAS				
Length of Pipe - Ft.	Pipe Capacity - BTU Per Hour Input Includes Fittings			
	Copper Tubing*		Iron Pipe	
	5/8"	3/4"	1/2"	3/4"
20	131,000	216,000	189,000	393,000
40	90,000	145,000	129,000	267,000
60	72,000	121,000	103,000	217,000

\* Outside diameter

The length of pipe or tubing should be measured from the gas meter or propane second stage regulator.

FIG. 13 - GAS PIPE SIZES

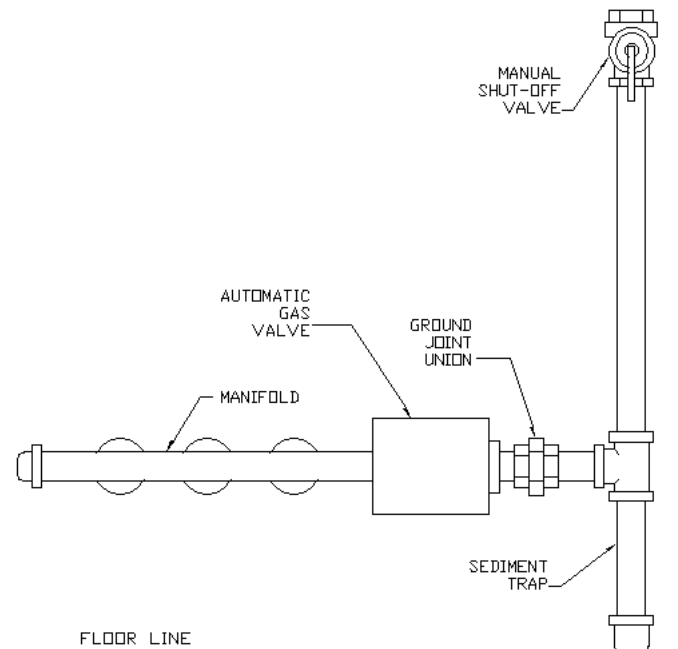

# Electrical Wiring

All electrical work must conform to local codes as well as the National Electrical Code, ANSI/NFPA-70, latest revision.

## ELECTRIC POWER SUPPLY

Run a separate 120 volt circuit from a separate over current protective device in the electrical service entrance panel. This should be a 15 ampere circuit. Locate a shut-off switch at the boiler. It must be turned off during any maintenance. Connect 120 volt power supply to aquastat terminals L1 (HOT) and L2. The boiler, when installed, must be electrically grounded in accordance with the requirements of the authority having jurisdiction or, in the absence of such requirements, with the National Electrical Code, ANSI/NFPA No. 70-latest revision. Run a 14 gauge or heavier copper wire from the boiler to a grounded connection in the service panel or a properly driven and electrically grounded ground rod.

### WARNING

Turn off electric power at fuse box before making any line voltage connections. Follow local electrical codes.

## INSTALL YOUR THERMOSTAT

The thermostat location has an important effect on the operation of your boiler system. **BE SURE TO FOLLOW THE INSTRUCTIONS INCLUDED WITH YOUR THERMOSTAT** Locate the thermostat about five feet above the floor on an inside wall. It may be mounted directly on the wall or on

a vertically mounted outlet box. It should be sensing average room temperature, so avoid the following:

### DEAD SPOTS:

- Behind doors
- Corners and alcoves

### HOT SPOTS:

- Concealed pipes
- Fireplace
- TV sets
- Radios
- Lamps
- Direct sunlight
- Kitchens

### COLD SPOTS:

- Concealed pipes or ducts
- Stairwells - drafts
- Doors – drafts
- Unheated rooms on other side of wall

Set heat anticipator at .2 amps. 24 volt thermostat connects to aquastat terminals T and TV.

## VENT DAMPER WIRING

The boiler is equipped with a factory wired harness with 4 pin molex plug, that plugs into a 4 pin molex receptacle inside the vent damper operator.

The vent damper must be connected for the boiler to operate.

Wiring diagrams follow for the various different models.

### CAUTION

Label all wires prior to disconnection when servicing controls. Wiring errors can cause improper and dangerous operation. Verify proper operation after servicing.

# WIRING DIAGRAMS FOR HOT WATER BOILERS

## INTERMITTENT IGNITION

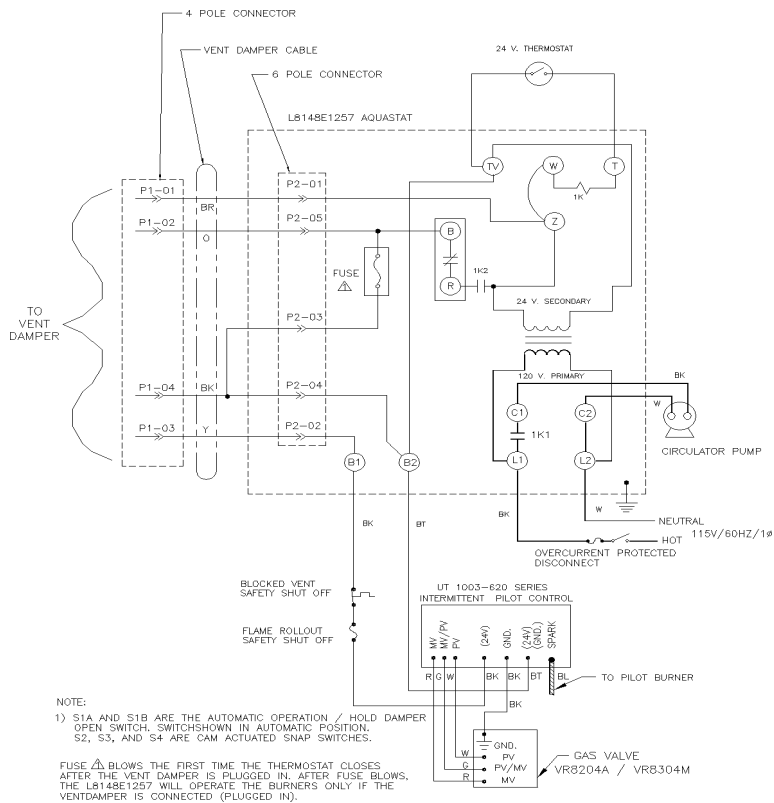
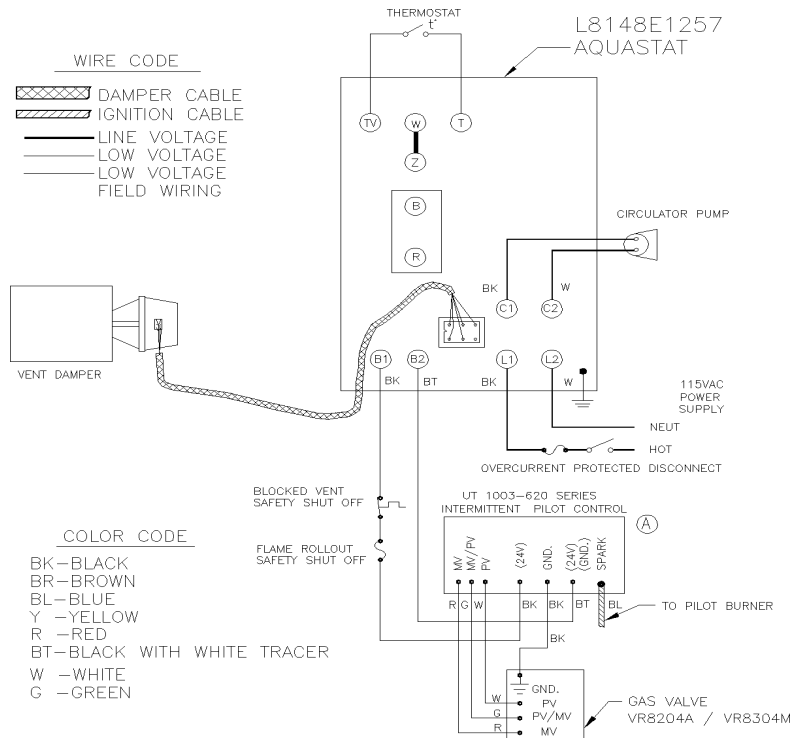

**IF ANY OF THE ORIGINAL WIRE AS SUPPLIED WITH THIS APPLIANCE MUST BE REPLACED, IT MUST BE REPLACED WITH TYPE 105°C THERMOPLASTIC WIRE OR ITS EQUIVALENT.**

# WIRING DIAGRAMS FOR HOT WATER BOILERS

## STANDING PILOT

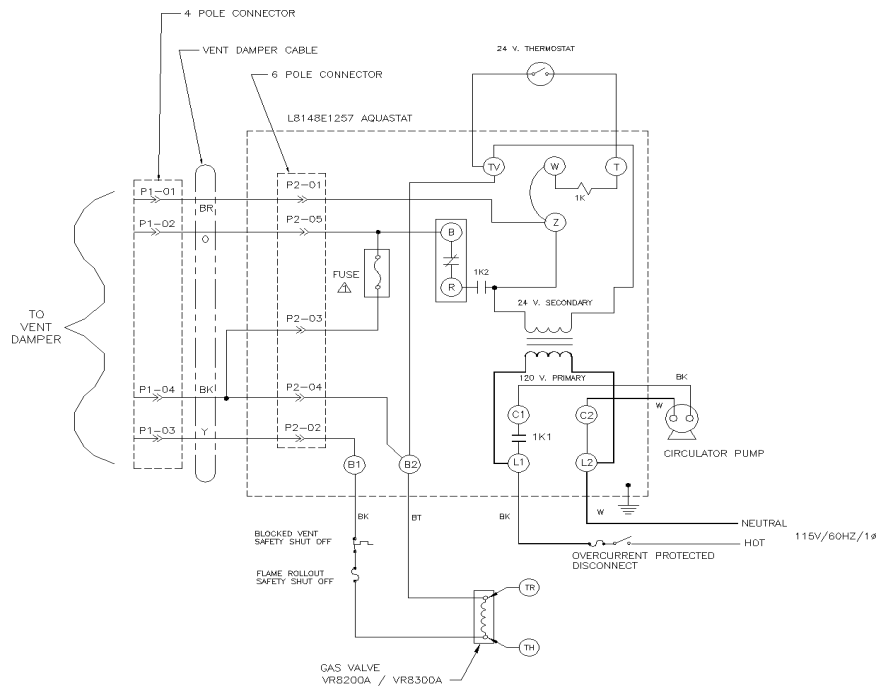
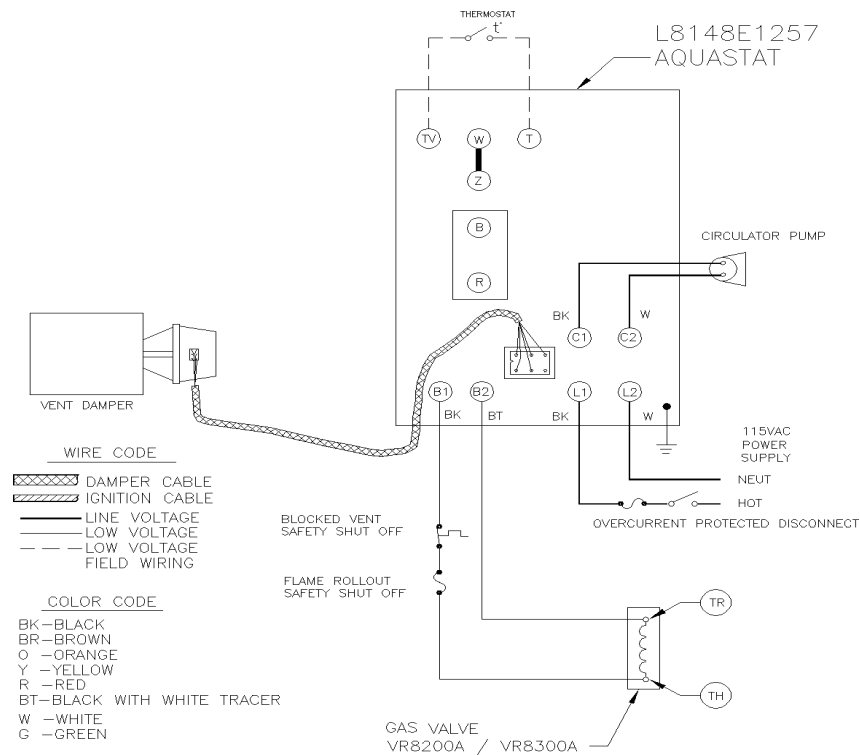

NOTE:  
S1A AND S1B ARE THE AUTOMATIC OPERATION / HOLD DAMPER OPEN SWITCH. SWITCH SHOWN IN AUTOMATIC POSITION.  
S2, S3, AND S4 ARE CAM ACTUATED SNAP SWITCHES.

FUSE  $\Delta$  BLOWS THE FIRST TIME THE THERMOSTAT CLOSURES AFTER THE VENT DAMPER IS PLUGGED IN. AFTER FUSE BLOWS, THE L8148E1257 WILL OPERATE THE BURNERS ONLY IF THE VENT DAMPER IS CONNECTED (PLUGGED IN).

**IF ANY OF THE ORIGINAL WIRE AS SUPPLIED WITH THIS APPLIANCE MUST BE REPLACED, IT MUST BE REPLACED WITH TYPE 105°C THERMOPLASTIC WIRE OR ITS EQUIVALENT.**

# Equipment and Optional Accessories - What They Do

## RELIEF VALVE

You must have a relief valve on your boiler. Water expands as it is heated. If there is no place for the water to expand into, water pressure will build up inside the boiler and system. Should this happen, the relief valve will automatically open at a predetermined pressure. This will relieve the strain on the boiler and system. Run a pipe from the relief valve outlet (pipe must be same size as outlet and the open end must not be threaded) to an open drain, tub or sink, or other suitable drainage point not subject to freezing. Failure to do so may cause water damage or injury should relief valve release.

## EXPANSION TANK

In a properly assembled system, the expanding water flows into a expansion tank. This tank should be of the correct size. The tank is filled with air. As the water expands it compresses the air in the tank to form an air pressure cushion. This "spring-like" cushion serves to maintain correct operating water pressure regardless of water temperature. This assures a "full measure" of a water, even in the highest radiation unit of the system. It also prevents blowing off of the relief valve. The air in the tank in the beginning (with system filled with cold water) is sufficient for proper operation. The tank also serves as a trap for excess air in the system. The air would cause gurgling in the pipes and inefficient circulation in the radiators if left in the system .

It is possible for a tank to become "waterlogged" (filled with water). It can also become overfilled with air. This can happen after filling the system with new water. Fittings provided on the tank and in the line to the tank are for bleeding off excess water or air.

When installing this tank, it is important: 1) That the tank be higher than the boiler top. 2) That the pipe to the tank continuously rises up to the tank (so that air can "bubble" up to it).

## DIAPHRAGM TYPE EXPANSION TANK

The diaphragm type expansion tank (EX-TROL) takes the place of the conventional expansion tank. Carefully read the instructions packed with your EX TROL tank assembly.

The EX-TROL tank comes to you with a 10-12 pounds per square inch air charge. This is the same as the pressure produced in the system by the automatic fill valve. When the system is first filled, the EX TROL tank will contain little or no water.

As the water is heated its pressure increases. It expands into the EX-TROL tank, compressing the air in the tank. This compressed air cushion permits the water in the system to expand as the temperature changes. The diaphragm type tank can be mounted on the air purger fitting or at any convenient place in the supply or return line.

## AIR ELIMINATING FITTING (AIR PURGER)

An air purger is used to remove excess air from the system. It is installed in the supply line. It will eliminate air from the water before it reaches the radiators and bleed off this air.

## MAIN AIR VENT FOR DOWN FLOW SYSTEMS OR DIAPHRAGM TYPE EXPANSION TANK

Before a system is filled with water, there is air in the pipes and radiation units. Some of it will be trapped as the system is filled . It is possible to eliminate most of this air through the air vent on the radiation units. A main air vent will speed and simplify this. It should be installed on the highest point in the supply main when all radiation is below top of boiler.

## AUTOMATIC FILL VALVE

For safe, efficient operation, a hot water system must be **completely filled** with water. Adding new water, when needed can be done manually (by use of a hand valve in the water supply line). This requires regular attention to the system's needs. An automatic fill valve accomplishes this without attention. It is installed in the supply line on hot water boilers only. The valve operates through water pressure differentials. It does not require an electrical connection.

## DRAIN VALVE

This manual valve Provides a means of draining all water from the boiler and system. It is often installed in the 3/4" tapping at the bottom of the end boiler section. Or it can be installed in a tee where the return line enters the boiler.

## WATER TEMPERATURE CONTROL

The water temperature limit control in the relay is adjustable and may be set as necessary. It may be set as low as 140°F, or as high as 240°F. This depends on the type and amount of radiation involved and weather conditions.

## CIRCULATING PUMP

Every forced hot-water system requires a circulating pump. A separate pump or zone valve is required for each zone, if you have a two or more zone system. This pump must have the capacity to provide the circulation required by your system. The pump is connected into the main just ahead of the boiler. It is also wired to the electrical system.

## VENT DAMPER

This product is an automatic, motorized stack damper that has been developed to increase the efficiency of heating system by reducing standby losses from the heating apparatus and the conditioned air space. The damper closes the chimney vent when the burner is off and fully opens it when combustion is required.

## **ROLLOUT SWITCH (FLAME ROLLOUT SAFETY SHUTOFF)**

The rollout switch is a temperature-sensitive fuse link device. It is located on the boiler base just outside the fire box. In the event of heat exchanger flueway blockage causing flame to roll out of the fire box, the fuse does not change in appearance when blown.

If the rollout switch blows, it must be replaced with an exact replacement. Check heat exchanger flueways for blockage when restoring system to operating condition. DO NOT operate system without a rollout switch.

## **SPILL SWITCH (BLOCKED VENT SAFETY SHUTOFF)**

The spill switch is a manual reset disc thermostat with a fixed setpoint (340° F), and normally closed contacts. It is located at the relief opening of the integral draft diverter. In the event of chimney or venting system blockage causing products of combustion to spill out of the relief opening, the spill switch disc heats up and the spill switch contacts open, shutting down the flow of gas to the main burners by removing power to the gas valve.

In the event that the spill switch contacts open, the reset button on the back of the switch will pop up. The spill switch must be reset manually, after the switch has cooled off, by pushing the reset button down. Check the venting system and chimney for blockage when restoring the system to operating condition. DO NOT operate the boiler without a spill switch.

# **Starting Your Boiler**

## **HOW A HOT-WATER SYSTEM OPERATES**

Your entire heating system (boiler, piping and radiation units) is filled with water. As the water in the boiler is heated, it is pumped from the top of the boiler through the supply main to the radiation units. The cooler water in them flows back through the return main to the boiler. This provides positive and rapid response to the thermostat.

## **FILLING SYSTEM WITH WATER**

Close the air vents on all radiation units. Open the valves to these units. Make sure the boiler and expansion tank drain cocks are closed. The air bleed screw on the tank drain fitting should be closed. Open the valve in the line from the boiler to the expansion tank. Open the water inlet to your boiler and leave it open. Start with the **lowest** radiation unit. Open the air vent on this unit. When all the air has escaped and water starts to flow from the vent, close it. Go to the next radiation unit, and repeat this process. Repeat until you have covered

every radiation unit in the system (ending up at the highest unit in the system). If your units have automatic vents, this manual venting is unnecessary but it will speed up the proper filling of your system.

If your system is a closed expansion tank system, you may leave it open to refill the system automatically as needed. Check the temperature pressure gauge. Not the position of the hand indicating pressure. This should be between 10 and 15 lbs. Any lowering of this movable hand below 10 lbs. Will indicate loss of water due to leakage. The automatic fill valve should compensate for this. Instructions are packages with the valve.

### **WARNING**

**Never run water into a hot empty boiler.**

# For Your Safety Read Before Operating

**WARNING: If you do not follow these instructions exactly, a fire or explosion may result causing property damage, personal injury or loss of life.**

- A. Some boilers are equipped with an intermittent ignition device which automatically lights the pilot. Do **not** try to light the pilot by hand.

Some boilers are equipped with a continuous pilot and must be manually lighted. (See lighting instructions on page 15.) A match holder is included in the parts bag.

- B. BEFORE OPERATING smell all around the appliance area for gas. Be sure to smell next to the floor because some gas is heavier than air and will settle on the floor.

## WHAT TO DO IF YOU SMELL GAS

- Do not try to light any appliance.
- Do not touch any electric switch; do not use any phone in your building.

- Immediately call your gas supplier from a neighbor's phone. Follow the gas supplier's instructions.
- If you cannot reach your gas supplier, call the fire department.

- C. Use only your hand to push in or turn the gas control knob. Never use tools. If the knob will not push in or turn by hand, don't try to repair it, call a qualified service technician. Force or attempted repair may result in a fire or explosion.

- D. Do not use this appliance if any part has been under water. Immediately call a qualified service technician to inspect the appliance and to replace any part of the control system and any gas control which has been under water.

## Intermittent Ignition Boiler - VR8204A/VR8304M Gas Valve Operating Instructions

1. STOP! Read the safety information on page 14.
2. Set the thermostat to lowest setting.
3. Turn off all electric power to the appliance.
4. This appliance is equipped with an ignition device which automatically lights the pilot. Do **not** try to light the pilot by hand.

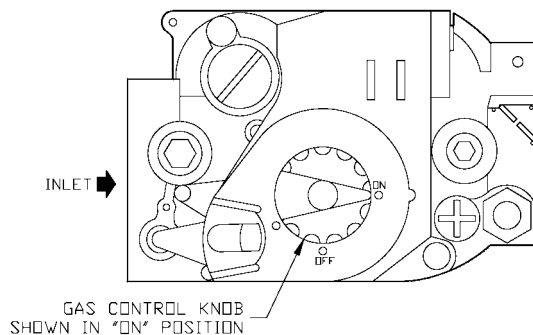

5. Remove lower front panel.
6. Rotate the gas control knob clockwise to "OFF" 

7. Wait five (5) minutes to clear out any gas. Then smell for gas, including near the floor. If you smell gas, STOP! Follow "B" in the safety information on page 19. If you don't smell gas, go to next step.
8. Rotate the gas control knob counterclockwise to "ON." 
9. Replace lower front panel.
10. Turn on all electric power to the appliance.
11. Set thermostat to desired setting.
12. If the appliance will not operate, follow the instructions "To Turn Off Gas To Appliance" and call your service technician or gas supplier.

## TO TURN OFF GAS TO APPLIANCE

1. Set the thermostat to lowest setting.
2. Turn off all electric power to the appliance if service is to be performed.
3. Push in gas control knob slightly and turn clockwise to "OFF" Do not force. 

# Continuous Pilot Boiler - VR8200A/VR8300A Gas Valve Operating Instructions

1. STOP! Read the safety information on page 14.
2. Set the thermostat to lowest setting.
3. Turn off all electric power to the appliance.
4. Remove lower front panel.
5. Rotate gas control knob slightly and turn clockwise to "OFF"

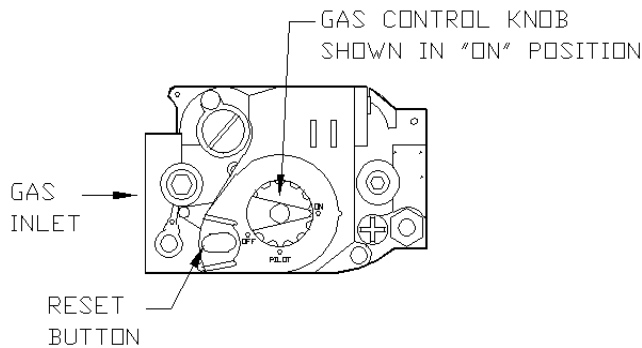

6. Wait five (5) minutes to clear out any gas. Then smell for gas, including near the floor. If you smell gas, STOP! Follow "B" in the safety information on page 19. If you don't smell gas, go to next step.
7. Find pilot - follow metal tube from gas control. The pilot is between two burner tubes as shown in Fig. 14.
8. Turn knob on gas control counterclockwise to "PILOT"

9. Rotate the gas control knob counterclockwise to "PILOT" Push down and hold the red reset button while you light pilot burner with a match.

After about one minute, release reset button. Pilot should remain lit. If it goes out, turn gas control knob clockwise to OFF To relight, repeat steps 5-9.

- If button does not pop up when released, stop and immediately call your service technician or gas supplier.
  - If the pilot will not stay lit after several tries, turn the gas control knob to "OFF" and call your service technician or gas supplier.
10. After pilot remains lit when red reset button is released, turn gas control knob counterclockwise to "ON."
  11. Replace lower front panel.
  12. Turn on all electric power to the appliance.
  13. Set thermostat to desired setting.

## TO TURN OFF GAS TO APPLIANCE

1. Set the thermostat to lowest setting.
2. Turn off all electric power to the appliance if service is to be performed.
3. Push in gas control knob slightly and turn clockwise to "OFF" Do not force.

# Operating Your Boiler

## AUTOMATIC GAS VALVE

The Automatic Gas Valve opens or closes according to the heat requirements of the thermostat and temperature limit control. It closes if the pilot goes out. Each individual control must be operating correctly before any gas can pass to the burners. Any one control can hold the gas supply from burner regardless of the demand of any other control.

## SAFETY PILOT

Safety Pilot prevents the flow of gas to burner if the pilot goes out, or will not ignite.

## GAS VALVE SAFETY SHUTDOWN TEST

1. For boilers equipped with continuous pilot, with main burners firing, disconnect the thermocouple from the gas valve. The gas valve should immediately shut off the main burners and the pilot.
2. For boilers equipped with intermittent ignition, with main burners firing, disconnect the ignition cable from the intermittent pilot control box. The gas valve should shut off the main burners. TURN OFF ELECTRIC POWER to boiler before reconnecting ignition cable, to prevent electric shock.

## RELIGHT

The electric and gas shall be off for 5 minutes before relighting.

## THERMOSTAT

Keep it set at a desired room temperature. If windows are to be opened or heat is not needed, move thermostat pointer to a lower setting.

## NOTE

In the event of failure of any component, the system will not operate or will go into safety lockout. The system is completely self-checking. On every call for heat, each component must be functioning properly to permit operation. On safety lockout the system has to be reset by turning the thermostat to the lowest setting for one minute, then back to the normal setting.

Safe lighting and other performance criteria were met with the gas manifold and control assembly provided on the boiler when the boiler underwent tests specified in ANSI Z21.13 - latest revision.



**FIG. 14 - LIGHTING PILOT**

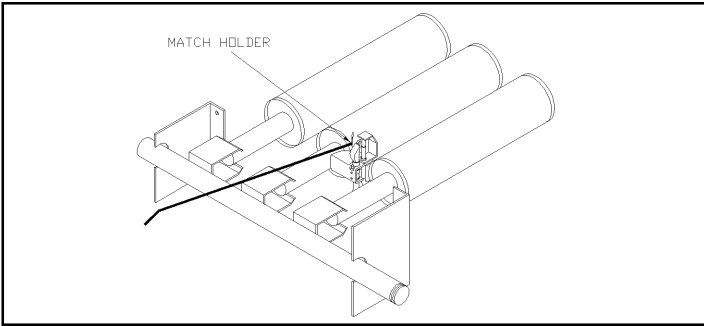

**FIG. 16 -VR8204A/VR8304M AUTOMATIC GAS VALVE**

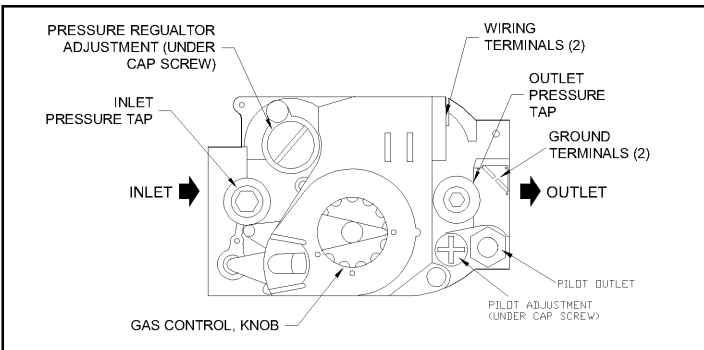

**FIG. 15 -VR8200A/VR8300A AUTOMATIC GAS VALVE**

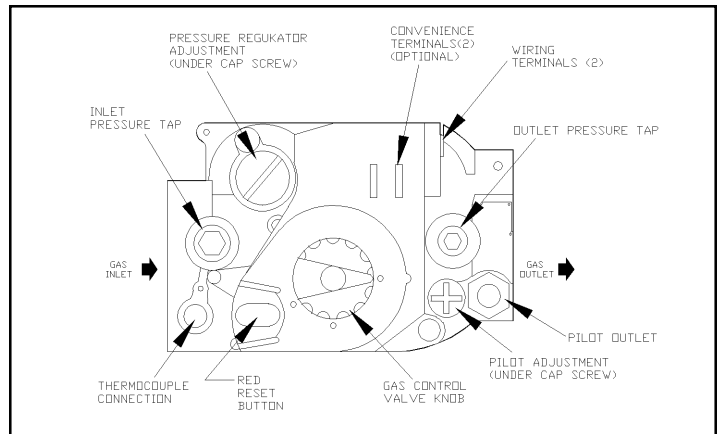

**FIG. 17**

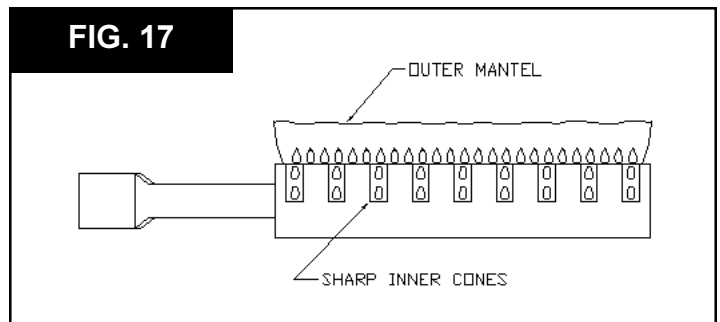

## Checking and Adjusting

### ADJUST PILOT BURNER

Pilot flame should surround 3/8" to 1/2" of the pilot sensor. Refer to Fig. 18. If flame needs adjusting, do it as follows:

1. Remove screw cover over pilot adjusting screw.
2. Insert small screwdriver and adjust flame as needed. Turn screw counterclockwise to increase flame, clockwise to decrease.
3. Replace screw cover over pilot adjusting screw.

### MAIN BURNER(S)

The main burners do not require primary air adjustment and are not equipped with primary air shutters. Main burner flames should form sharp blue inner cones in a softer blue outer mantel, with no yellow. Puffs of air from blowing on the flame or stamping on the floor will cause the flames to turn orange momentarily. This is not unusual. Remain still when observing the main burner flames. If the flame appearance is not correct, check main burner orifices and the burner throat and flame ports for dust and lint obstruction. It may be necessary to remove the rollout shield to observe the main burner flames. Replace rollout shield after observation. Refer to Figure 17.

### ADJUST LIMIT CONTROLS

Instructions for each control are included with the controls. These settings can be changed after you have had some

idea how the system works. Example: If your system does not give quite enough heat in very cold weather, you can raise the limit setting to 220° F Use the boiler gauge to check your settings. Make the adjustments according to its readings.

Check thermostat operation. When set above temperature indicated on the thermometer, boiler should ignite. Make certain the thermostat turns off the boiler when room temperature reaches the selected setting and starts the boiler operating when room temperature falls a few degrees.

After setting limit control to limit setting, check to see if it shuts off the gas supply to the burners. Turn your thermostat up to call for heat and let your boiler run until the temperature of the water reaches the limit setting. The gas valve should shut off and the circulator keep running until the thermostat is satisfied, or the water cools enough to restart the burners through the limit control.

Finally, set the thermostat for the desired temperature. Special conditions in your home and the location of the thermostat will govern this setting.

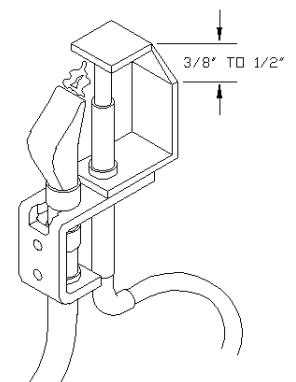

**FIG. 18**

### RECOMMENDED BOILER WATER TEMPERATURES

Type of Heating Unit	Limit Control Setting
Standing Radiators.....	180° F.
Baseboard and Convector Radiators.....	200° F.

# Maintaining Your Boiler

## BURNERS

A visual check of the pilot and main burner flames should be made at least once each year, preferably at the beginning of the heating season. See page 17

## RELIEF VALVE

This valve should open automatically if the system pressure exceeds the pressure rating (usually 30 psi) of the relief valve. Should it ever fail to open under this condition, shut down your system. Drain the system until system pressure is reduced below the relief valve pressure rating. If valve discharge occurs, or if valve fails to open as described above, contact an authorized contractor or qualified service technician to replace the relief valve and inspect the heating system to determine the cause, as this may indicate an equipment malfunction.

This valve should be tested every month during periods of boiler operation, and at the beginning and end of any extended non-service period. Prior to testing, make certain discharge pipe is properly connected to valve outlet and arranged so as to contain and safely dispose of boiler discharge. Test at normal system operating pressure. Hold the trip lever fully open for at least five seconds in order to flush free any sediment that may lodge on the valve seat. Then permit the valve to snap shut.

## EXPANSION TANK

As previously noted, this tank may become waterlogged, or may receive an excess of air. Frequent automatic opening of the relief valve indicates water logging. A high boiler temperature accompanied by unusually low radiation unit temperature (and "knocking") indicates excess air in tank.

To correct either condition, close the valve between the boiler and the tank. Drain the tank until it is empty. Check all the tank plugs and fittings. Tighten as necessary. Open the valve between the boiler and tank. Water will rise to the normal height in the tank if you have an automatic fill valve (otherwise, manually refill the system).

## BOILER FLUE PASSAGES

Under normal operating conditions, with the burners properly adjusted, it should not be necessary to clean the boiler flue gas passages. However, to assure trouble-free operation, we recommend that you have the flue passages, burner

adjustment, and operation of the controls checked once each year by a competent Service Technician.

Before the start of each season (or whenever system has been shut down for some time) recheck the whole system for leaks ... and recheck the boiler and vent pipe for leaks. Replace or patch any boiler seals that are faulty.

## VENT PIPE

The venting of this unit is very important and the piping should be checked at least once a season. If the vent piping shows any sign of leaking, replace it immediately.

## WATER SYSTEM

If system is to remain out of service during freezing weather, always **drain it** completely (water left in to freeze will crack the pipes and/or boiler).

## CLEANING YOUR BOILER AND BURNERS

Flue passages between sections should be examined yearly and cleaned if necessary. To clean, remove burners, pilot, and vent pipe. Remove top and front jacket panels. Remove the two screws attaching the intermediate front panel to the left and right side jacket panels. Remove the draft diverter and intermediate front panel as a unit. Carefully remove the cerafelt gasket strips. Clean passageways between sections with a flexible handle wire brush. Remove dirt from bottom of boiler and from between sections by vacuuming. Make sure all flame ports in burners are open and clear. Shake out or blow out all loose dirt in burners. Reseal seams between adjacent sections as necessary with 400° F RTV silicone sealant. Reassemble all parts. Be sure to check tightness of pilot connections and condition of burner flames after reassembly (see Figures 17 and 18). Be sure vent pipe connections to chimney are secure and no obstructions are present.

## CIRCULATOR PUMP ISOLATION VALVES

The isolation valves in the circulator pump flanges should be operated manually once or twice per year to prevent the valves from becoming stuck in the open position. Rotate the valves from the open position to the closed position and back to the open position.

# Service Hints

You may avoid inconvenience and service calls by checking these points before you call for service.

## FOR YOUR SAFETY WHAT TO DO IF YOU SMELL GAS

1. Do Not try to light any appliance.
2. Do not touch any electric switch, do not use the phone.
3. Leave the building immediately, then call your gas supplier.
4. If you cannot reach the gas supplier, call the fire department.

## IF YOUR SYSTEM IS NOT HEATING OR NOT GIVING ENOUGH HEAT . . .

Possible Cause	What to do
Thermostat is not set correctly	Reset thermostat above room temperature
Burner is not operating properly	Check flame. If it is yellow, the burner is not getting enough air. Or, if flame is blue and noisy and seems to lift off the burner, the burner is getting too much air. Contact your service technician.
No electric power to boiler	Check over current protection. Check to be sure electric power supply circuit is "ON".
Controls out of adjustment	Reset according to instructions.
Radiators not heating	Open radiator vents to excess air. Check flow control valve (if used). It may be in closed position.
Circulating pump not running	Check over current protection. Check relay operation.
Poor electrical contact	Check all control terminals and wire joints.
Rollout switch blown	Have your service technician check heat exchanger for blockage. Replace rollout switch with exact replacement.
Spill switch blown	Have your service technician check venting system and chimney for blockage, or down draft condition. Reset spill switch.
Vent damper not operating	Consult troubleshooting guide in Effikal manual, packaged with vent damper.

## IF BURNER IS NOISY . . .

Possible Cause	What to do
Gas input amount is incorrect	Contact your service technician.

## RELIEF VALVE LEAKING . . .

Possible Cause	What to do
Dirt on seat	Open valve manually. Allow water to run and clear valve seat.
Water logged expansion tank	Drain tank, see instructions.

**HAVE YOUR SERVICE TECHNICIAN CHECK ANY PROBLEM YOU ARE UNABLE TO CORRECT.**

# Repair Parts

## GAS – FIRED HOT WATER BOILERS

**– IMPORTANT –  
READ THESE INSTRUCTIONS BEFORE ORDERING**

All parts are listed in the following Parts List may be ordered through your nearest supplier.

When ordering parts, first obtain the Model Number from the data plate on your boiler, than determine the Part No. (not the Key No.) and the Description of each part from the following illustrations and list. Be sure to give us all this information:

The Part No. – The Part Description – The Boiler Model No.

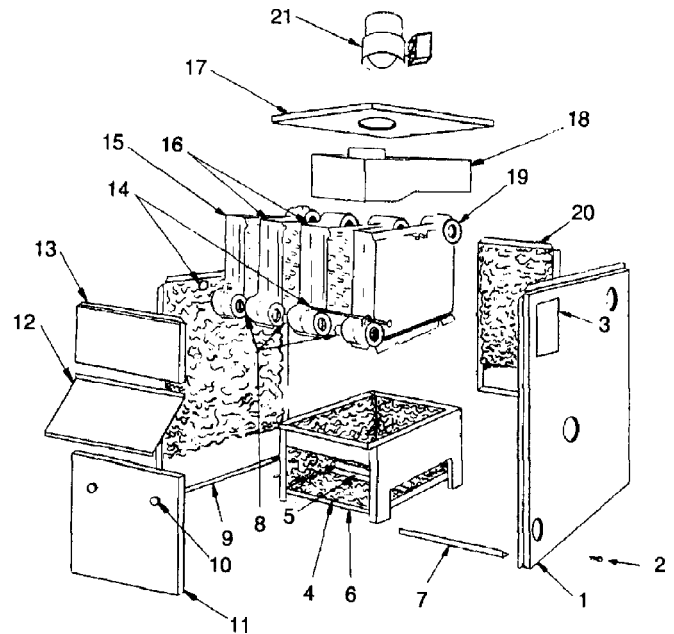

## JACKET - SECTION AND BASE PARTS

**THIS IS A REPAIR PARTS LIST - NOT A PACKAGING LIST**

KEY NO.	DESCRIPTION	3 SECTION	4 SECTION	5 SECTION	6 SECTION	7 SECTION	8 SECTION	9 SECTION
		Part No.	Part No.	Part No.	Part No.	Part No.	Part No.	Part No.
1	Jacket, Right Side Panel	425-00-802	425-00-802	425-00-802	425-00-802	425-00-802	425-00-802	425-00-802
2	#10 x 1/2 Sheet Metal Screw	146-95-074	146-95-074	146-95-074	146-95-074	146-95-074	146-95-074	146-95-074
3	Rating Plate	146-80-901	146-80-901	146-80-901	146-80-901	146-80-901	146-80-901	146-80-901
4	Base Insulation - Base Sides (2)	146-14-130	146-14-130	146-14-130	146-14-130	146-14-130	146-14-130	146-14-130
	- Base Front	146-14-113	146-14-114	146-14-115	146-14-116	146-14-117	146-14-118	146-14-119
	- Base Rear	146-14-123	146-14-124	146-14-125	146-14-126	146-14-127	146-14-128	146-14-129
5	Base Baffle	425-00-643	425-00-644	425-00-645	425-00-646	425-00-647	425-00-648	425-00-649
6	Base	425-00-663	425-00-664	425-00-665	425-00-666	425-00-667	425-00-668	425-00-669
7	Jacket Tie Bar	425-00-653	425-00-654	425-00-655	425-00-656	425-00-657	425-00-658	425-00-659
8	Push Nipple	433-00-976	433-00-976	433-00-976	433-00-976	433-00-976	433-00-976	433-00-976
9	Jacket, Left Side Panel	425-00-801	425-00-801	425-00-801	425-00-801	425-00-801	425-00-801	425-00-801
10	Knob, Service Door (Pair)	137-02-513	137-02-513	137-02-513	137-02-513	137-02-513	137-02-513	137-02-513
11	Jacket, Service Door	425-00-823	425-00-824	425-00-825	425-00-826	425-00-827	425-00-828	425-00-829
12	Jacket, Int'd. Panel	425-00-813	425-00-814	425-00-815	425-00-816	425-00-817	425-00-818	425-00-819
13	Jacket, Front Panel	425-00-811	425-00-804	425-00-805	425-00-806	425-00-807	425-00-808	425-00-809
14	1/4" Tie Rod, Nut	146-05-001	146-05-002	146-05-051	146-05-053	146-05-005	146-05-007	146-05-009
15	Boiler Section, Left	410-00-013	410-00-013	410-00-013	410-00-013	410-00-013	410-00-013	410-00-013
16	Boiler Section, Middle	410-00-015	410-00-015	410-00-015	410-00-015	410-00-015	410-00-015	410-00-015
17	Jacket, Top Panel	425-00-843	425-00-844	425-00-845	425-00-846	425-00-847	425-00-848	425-00-849
18	Draft Diverter	425-00-673	425-00-674	425-00-675	425-00-676	425-00-677	425-00-678	425-00-679
19	Boiler Section, Right	410-00-014	410-00-014	410-00-014	410-00-014	410-00-014	410-00-014	410-00-014
20	Jacket, Back Panel	425-00-833	425-00-834	425-00-835	425-00-836	425-00-837	425-00-838	633-00-1029
‡	Jacket Complete	739-00-1003	739-00-1004	739-00-1005	739-00-1006	739-00-1007	739-00-1008	739-00-1009
‡	Block Assembly (19, 16, 15, 14, 8)	410-00-331	410-00-431	410-00-531	410-00-631	410-00-731	410-00-831	410-00-931
‡	Combustable Floor Plate	146-14-031	146-14-031	146-14-031	146-14-031	146-14-032	146-14-032	146-14-032
‡	Cerafelt Gasket	146-14-018	146-14-018	146-14-018	146-14-018	146-14-018	146-14-018	146-14-018
21	Vent Damper	118-20-05	118-20-06	118-20-06	118-20-07	118-20-07	118-20-07	118-20-07
‡	Base Assembly (6, 5, 4)	433-00-663	433-00-664	433-00-665	433-00-666	433-00-667	433-00-668	433-00-669

‡ Not illustrated

# Repair Parts

FOR USE WITH NATURAL GAS ONLY

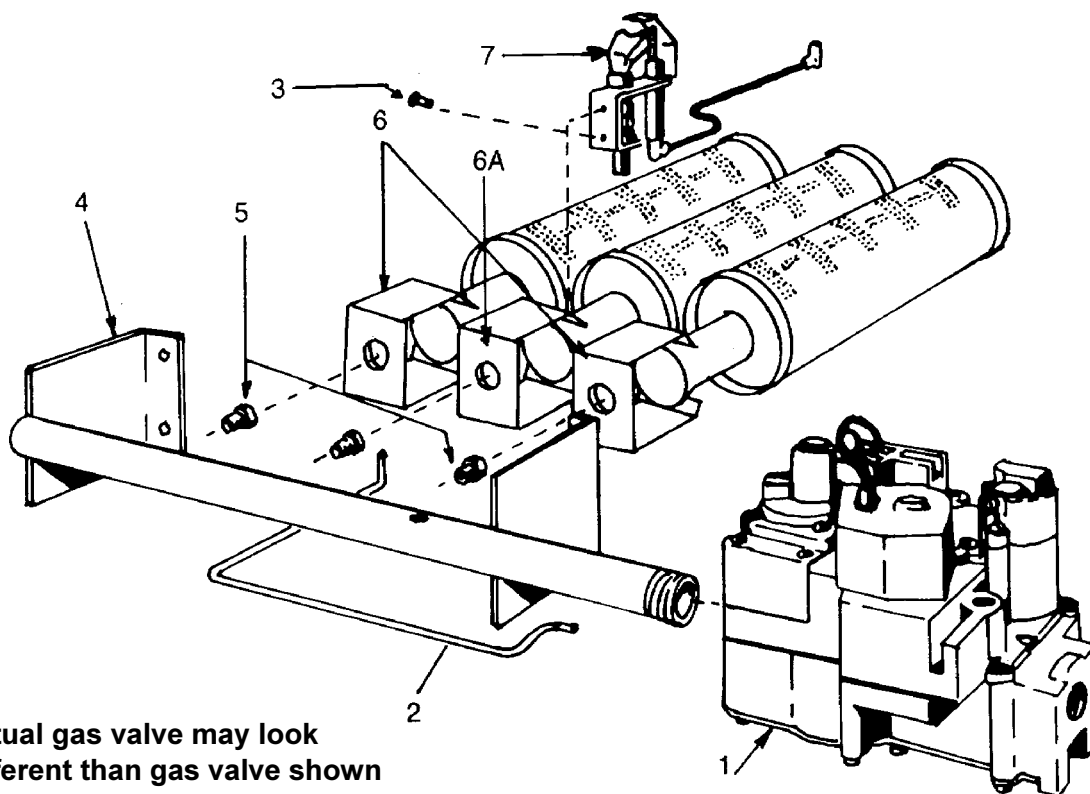

**NOTE: Actual gas valve may look different than gas valve shown**

## NATURAL GAS BURNERS AND MANIFOLD PARTS

THIS IS A REPAIR PARTS LIST - NOT A PACKING LIST

### ELECTRONIC INTERMITTENT IGNITION (Shown)

KEY NO.	DESCRIPTION	3 SECTION	4 SECTION	5 SECTION	6 SECTION	7 SECTION	8 SECTION	9 SECTION
		Part No.	Part No.	Part No.	Part No.	Part No.	Part No.	Part No.
1	24 Volt Gas Valve, Elect. Inter. Ignition	146-62-052	146-62-052	146-62-052	146-62-058	146-62-058	146-62-058	146-62-058
2	Pilot Tube	146-15-005	146-15-005	146-15-005	146-15-005	146-15-005	146-15-005	146-15-005
3	10-32 3/16 Hex Hd. Screw	146-95-301	146-95-301	146-95-301	146-95-301	146-95-301	146-95-301	146-95-301
4	Gas Manifold	146-16-033	146-16-034	146-16-035	146-16-013	146-16-014	146-16-015	146-16-016
5	Main Burner Orifice*	146-15-031	146-15-031	146-15-031	146-15-035	146-15-035	146-15-035	146-15-035
6	Main Burner, Regular**	146-15-532	146-15-532	146-15-532	146-15-532	146-15-532	146-15-532	146-15-532
6A	Main Burner, Pilot Mount	146-15-531	146-15-531	146-15-531	146-15-531	146-15-531	146-15-531	146-15-531
7	Pilot Burner	146-62-092	146-62-092	146-62-092	146-62-092	146-62-092	146-62-092	146-62-092
‡	Rollout Shield	425-00-933	425-00-934	425-00-935	425-00-936	425-00-937	425-00-938	425-00-939

### ALTERNATE PARTS FOR CONTINUOUS PILOT - 24 VOLT

1	24 Volt Gas Valve, Continuous Pilot	146-62-051	146-62-051	146-62-051	146-62-060	146-62-060	146-62-060	146-62-060
3	10-32 3/16 Hex Hd. Screw (2 req'd)	146-95-301	146-95-301	146-95-301	146-95-301	146-95-301	146-95-301	146-95-301
7	Pilot Burner	146-62-098	146-62-098	146-62-098	146-62-098	146-62-098	146-62-098	146-62-098
‡	Thermocouple	152-00-01	146-62-039	146-62-039	146-62-039	146-62-039	146-62-039	146-62-039

Quantity is 1 unless otherwise noted.

\* Requires 1 less than the number of sections.

\*\* Requires 2 less than the number of sections

‡ Not Illustrated

# Repair Parts

FOR USE WITH PROPANE GAS ONLY

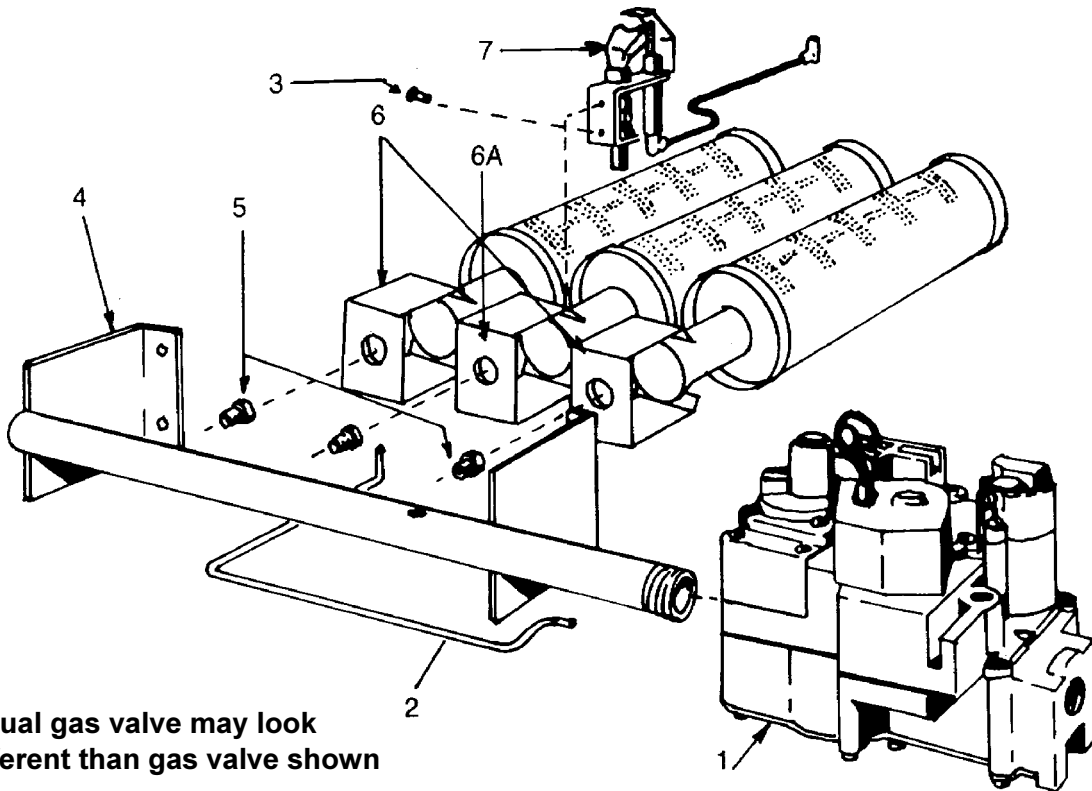

NOTE: Actual gas valve may look different than gas valve shown

## PROPANE GAS BURNERS AND MANIFOLD PARTS

THIS IS A REPAIR PARTS LIST - NOT A PACKING LIST

### ELECTRONIC INTERMITTENT IGNITION (Shown)

KEY NO.	DESCRIPTION	3 SECTION	4 SECTION	5 SECTION	6 SECTION	7 SECTION	8 SECTION	9 SECTION
		Part No.	Part No.	Part No.	Part No.	Part No.	Part No.	Part No.
1	24 Volt Gas Valve, Elect. Inter. Ignition	146-62-062	146-62-062	146-62-062	146-62-062	146-62-062	146-62-062	146-62-062
2	Pilot Tube	146-15-005	146-15-005	146-15-005	146-15-005	146-15-005	146-15-005	146-15-005
3	10-32 3/16 Hex Hd. Screw	146-95-301	146-95-301	146-95-301	146-95-301	146-95-301	146-95-301	146-95-301
4	Gas Manifold	146-16-010	146-16-011	146-16-012	146-16-013	146-16-014	146-16-015	146-16-016
5	Main Burner Orifice*	146-15-036	146-15-036	146-15-036	146-15-036	146-15-036	146-15-036	146-15-036
6	Main Burner, Regular**	146-15-532	146-15-532	146-15-532	146-15-532	146-15-532	146-15-532	146-15-532
6A	Main Burner, Pilot Mount	146-15-531	146-15-531	146-15-531	146-15-531	146-15-531	146-15-531	146-15-531
7	Pilot Burner	146-62-094	146-62-094	146-62-094	146-62-094	146-62-094	146-62-094	146-62-094
‡	Rollout Shield	425-00-933	425-00-934	425-00-935	425-00-936	425-00-937	425-00-938	425-00-939

### ALTERNATE PARTS FOR CONTINUOUS PILOT - 24 VOLT

1	24 Volt Gas Valve, Continuous Pilot	146-62-061	146-62-061	146-62-061	146-62-061	146-62-061	146-62-061	146-62-061
3	10-32 3/16 Hex Hd. Screw (2 req'd)	146-95-301	146-95-301	146-95-301	146-95-301	146-95-301	146-95-301	146-95-301
7	Pilot Burner	146-62-098	146-62-098	146-62-098	146-62-098	146-62-098	146-62-098	146-62-098
‡	Thermocouple	152-00-01	146-62-039	146-62-039	146-62-039	146-62-039	146-62-036	146-62-036

Quantity is 1 unless otherwise noted.

\* Requires 1 less than the number of sections.

\*\* Requires 2 less than the number of sections

‡ Not Illustrated

# Repair Parts

## BOILER CONTROLS AND PIPING

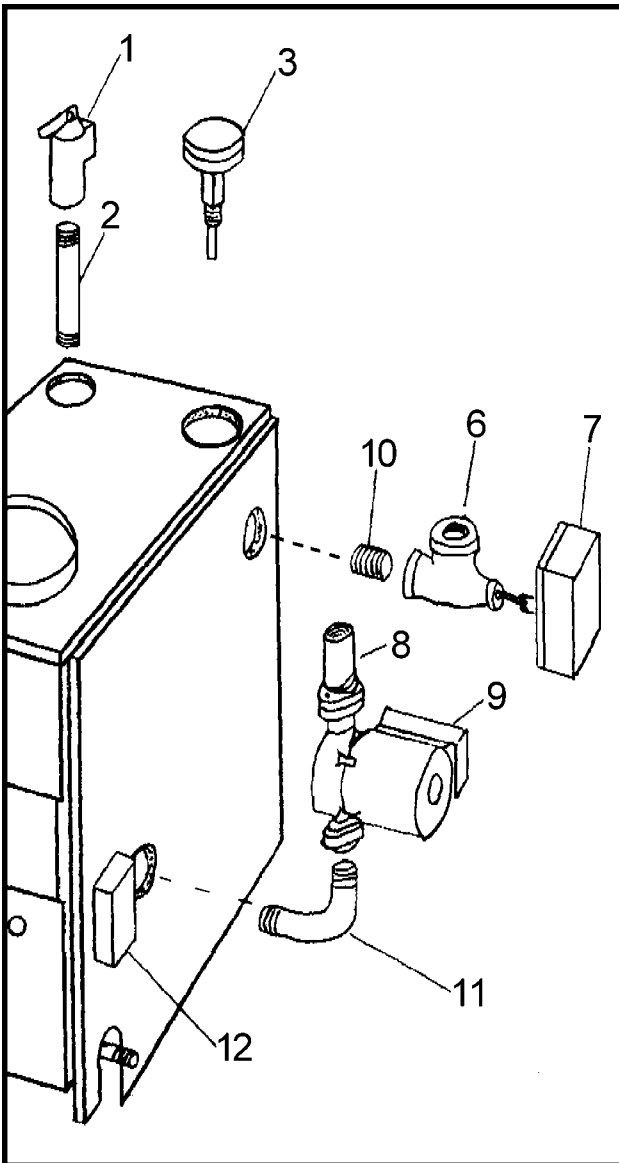

Key No.	Description	Part No.
1	3/4" ASME Relief Valve	146-22-011
2	3/4" x 6 1/2" Nipple	146-07-002
3	Temperature Pessure Gauge	146-23-007
6	1 1/4" x 3/4" x 1 1/4" Tee	1510001
7	Aquastat Relay	1010002
‡	Isolation Valve Set - Grundfos	14626043
8	Isolation Valve Set - Taco	14626043
‡	Cast Iron Flange Set - Grundfos	146-26-050
‡	Cast Iron Flange Set - Taco	146-26-049
‡	Grundfos UP15-42F Circulator	CI-006.01
9	Taco 007 Circulator	CI-001.03
10	1 1/4" x 2 1/2" Nipple	146-07-044
11	1 1/4" Bent Return Nipple	146-07-003
12	Intermittent Pilot Control	146-62-070
‡	Spill Switch (36TX16-6282) 280° F	146-60-002
‡	Rollout Switch	146-29-002
‡	5" Vent Damper	1182005
‡	6" Vent Damper	1182006
‡	7" Vent Damper	1182007
‡	Vent Damper Operator (Motor)	1140002
‡	2 1/2" x 1 1/4" Bushing (2 Required)	146-93-008
‡	2 1/2" Plug	146-93-024
‡	2 1/2" x 3/4" Bushing	146-93-083
‡	1/2" Plug (3 Req'd)	1395003
‡	400° F Black Silicone Rubber Adhesive Sealant (10.3 oz. Cartridge)	146-06-020

‡ Not illustrated

