



INDIRECT-FIRED WATER HEATERS

FOR SINGLE WATER HEATER
INSTALLATIONS

INSTALLATION, OPERATION & MAINTENANCE MANUAL

30, 40, 50, 60, 80, 85, 115
Gallon

L = Low Boy Profile

C = Commercial Pipe
Connections

HQ = High Output

XHQ = Extra High Output



*Conforms to UL STD 174
Certified to CAN/CSA STD C22.2 No. 110-94*



ECR International, Inc.

2201 Dwyer Avenue, Utica NY 13501

web site: www.ecrinternational.com

Information and specifications outlined in this manual in effect at the time of printing of this manual. ECR International, Inc. reserves the right to discontinue, change specifications or system design at any time without notice and without incurring any obligation, whatsoever.

An ISO 9001-2008 Certified Company

P/N# 615000054, Rev. C [12/2014]

MODELS

H ₂ OI30	H ₂ OI80HO
H ₂ OI40	H ₂ OI80HOC
H ₂ OI40L	H ₂ OI85XHOC
H ₂ OI50	H ₂ OI115
H ₂ OI60	H ₂ OI115HO
H ₂ OI60HO	H ₂ OI115HOC
H ₂ OI60L	H ₂ OI115XHOC
H ₂ OI80	

Table of Contents

I. General Information.....	3
II. Pre-installation Considerations	5
III. Piping	11
IV. Electrical.....	15
V. Operation.....	15
VI. Maintenance	20
VII. Troubleshooting	22

SAVE THESE INSTRUCTIONS

Hazard Definitions

The following defined terms are used throughout this manual to bring attention to the presence of hazards or various risk levels or to important information concerning the life of the product.

▲ DANGER Indicates a presence of hazards that WILL cause severe personal injury, death or substantial property damage.

▲ WARNING Indicates a presence of hazards that CAN cause severe personal injury, death or substantial property damage.

▲ CAUTION Indicates a presence of hazards that will or can cause minor personal injury, or property damage.

NOTICE Indicates special instructions on installation, operation or maintenance that are important but not related to personal injury or property damage.

I. General Information

IMPORTANT INFORMATION – READ CAREFULLY

NOTE: The equipment shall be installed in accordance with those installation regulations required in the area where the installation is to be made. These regulations shall be carefully followed in all cases. Authorities having jurisdiction shall be consulted before installations are made.

All wiring on water heaters shall be in accordance with the National Electrical Code and/or local regulations.

WARNING

Improper installation, adjustment, alteration, service or maintenance can cause property damage, personal injury, or loss of life. Read and understand the entire manual before attempting installation, start-up, operation, or service. Installation and service must be performed only by an experienced, skilled installer or service agency.

This water heater contains very hot water under high pressure. Do not unscrew any pipe fittings or attempt to disconnect any components of this water heater without positively assuring that the water is cool and has no pressure. Always wear protective clothing and equipment when installing, starting up or servicing this water heater to prevent scalding injuries. Do not rely on the pressure and temperature gauges to determine the temperature and pressure of the water heater. This water heater contains components that become very hot when the boiler is operating. Do not touch any components unless they are cool.

Failure to follow all instructions in the proper order can cause personal injury or death. Read all instructions, including all those contained in component manufacturers' manuals before installing, starting up, operating, maintaining, or servicing the water heater.

CAUTION

To reduce the risk of excessive pressures and temperatures in this water heater, install temperature and pressure protective equipment required by local codes but no less than a combination temperature relief valve certified by a nationally recognized testing laboratory that maintains periodic inspection of production of listed equipment or materials, as meeting the requirements for Relief Valves and Automatic Shutoff Devices for Hot Water Supply Systems, ANSI Z21.22-latest edition. This valve must be marked with a maximum set pressure not to exceed the marked working pressure of the water heater. Install the valve into an opening provide and marked for this purpose in the water heater, and orient it or provide tubing so that any discharge from the valve will exit only within 6 inches above, or at any distance below, the structural floor, and cannot contact any live electrical part. The discharge opening must not be blocked or reduced in size under any circumstances.

These water heaters with single-wall stainless steel heat exchangers meet the Uniform Plumbing Code for installation in potable water systems provided that:

- The boiler water, including additives, is practically non-toxic, having a toxicity rating of class 1 as listed in Clinical Toxicology of Commercial Products, latest edition.
- The boiler water pressure is limited to maximum 30 psig by an approved safety or relief valve.
- The heat transfer medium is potable water or contains only substances that are recognized as safe by the U.S. Food and Drug Administration. (FDA)
- The pressure of the heat transfer medium is maintained less than the normal minimum operating pressure of the potable water system.

The maximum boiler water supply temperature to the indirect heat exchanger must not exceed 240 deg. F (115 deg. C). Improper water quality will reduce the life of the water heater. Hard water, sediment, high or low PH and high levels of chlorides in the domestic water should be avoided. Be sure that PH levels fall between 6 and 8 and dissolved chlorides are less than 100 ppm. A filter must be used where sediment is greater than 5 microns in size in the water supplied to the unit. A water softening system is recommended for areas with hard water. In cases where water quality is unknown, a qualified water treatment expert should be consulted.

NOTICE: Damage to tanks caused by improper water quality is not covered under the warranty.

⚠ DANGER

DO NOT store or use gasoline or other flammable vapors or liquids in the vicinity of this or any other appliance.

If you smell gas vapors, DO NOT try to operate any appliance - DO NOT touch any electrical switch or use any phone in the building. Immediately, call the gas supplier from a remote located phone. Follow the gas supplier's instructions or if the supplier is unavailable, contact the fire department.

⚠ DANGER

This water heater is supplied with an adjustable thermostat to control the water temperature. Hot water temperatures required for automatic dishwashers and laundry use can cause scald burns resulting in serious personal injury and/or death. The temperature at which injury occurs varies with the person's age and the time of exposure. The slower response time of disabled persons increases the hazard to them. NEVER allow small children to use a hot water tap or to draw their own bath water. NEVER leave a child or disabled person unattended in a bathtub or a shower. NEVER allow small children to use a hot water tap or to draw their own bath water. NEVER leave a child or disabled person unattended in a bathtub or a shower.

II. IMPORTANT SAFETY INSTRUCTIONS

⚠ WARNING

– When using electrical appliances, basic safety precautions to reduce the risk of fire, electric shock, or injury to persons should be followed, including:

READ ALL INSTRUCTIONS BEFORE USING THIS INDIRECT WATER HEATER.

1. Install or locate this water heater only in accordance with the provided installation instructions
2. Use this water heater only for its intended use as described in this manual.
3. As with any appliance, close supervision is necessary when used by children.
4. Do not operate this water heater, if it is not working properly, or if it has been damaged or dropped.
5. This water heater should be serviced only by qualified personnel. Contact nearest authorized service facility for examination, repair, or adjustment.

II. Pre-installation Considerations

Inspect shipment carefully for signs of damage. All equipment is carefully inspected and packed. Manufacturer's responsibility ceases upon delivery of the water heater to the carrier in good condition. Any claims for damage or shortage, must be filed immediately against the carrier by the consignee. No claims for variances or shortages will be allowed by the Manufacturer, unless they are presented within sixty days after receipt of the equipment.

Installation must conform to the requirements of the authority having jurisdiction. In the absence of such requirements, installation must conform to the National Plumbing Code and the National Electrical Code ANSI/NFPA No. 70, current edition.

IMPORTANT CONSIDERATIONS BEFORE INSTALLATION

1. Water Heater Sizing.

Choose the water heater model based on the expected water usage for the given site. The average residence with one shower or more will require a Model 40 or larger. The Model 30 should only be considered for residences with minimal water demand, or for commercial applications without showers. See Tables 2 and 3.

Consult ASHRAE sizing guides and other references.

Factors that increase water demand dramatically include high flow shower heads, hot tubs, and the use of more than one shower at a time. Increase the tank size if these factors are present. Consult ASHRAE sizing guides and other references.

Dimensions, weights, ratings, and capacities are outlined in Table 1.

2. Boiler Sizing.

The water heater will provide the rated performance only if it is used with a boiler with a heating capacity of at least as much as the capacity ratings in Tables 2 and 3. If the boiler has less capacity, the water heating output will be reduced.

NOTICE

If the boiler takes longer to heat up from a cold start, hot water shortage may occur.

The maximum heat transfers through the coil (heat input) of the water heaters at 240 deg. F boiler supply temperature and 210 deg. F potable water temperature are as follows:

- Models 30 – 115 single coil units and models 60-D, 80-D, and 115-D dual coil units are less than 96,000 BTU/HR.
- Models 80-HO, 115-HO, 80-HO-C, and 115-HO-C high output units are less than 84,000 BTU/HR.
- Models 85-XHO and 115-XHO, the extra high output series, are less than 175,000 BTU/HR.

Potable water temperature is limited to below 210 deg. F and nominal water containing capacity is below 120 gallons for all indirect models.

Accordingly, per Part HLW-101.2, Section IV of the ASME Boiler and Pressure Vessel Code, all indirect water heater products are exempt from compliance with the code.

Check with local codes for applicability

STANDARD AND HO UNITS

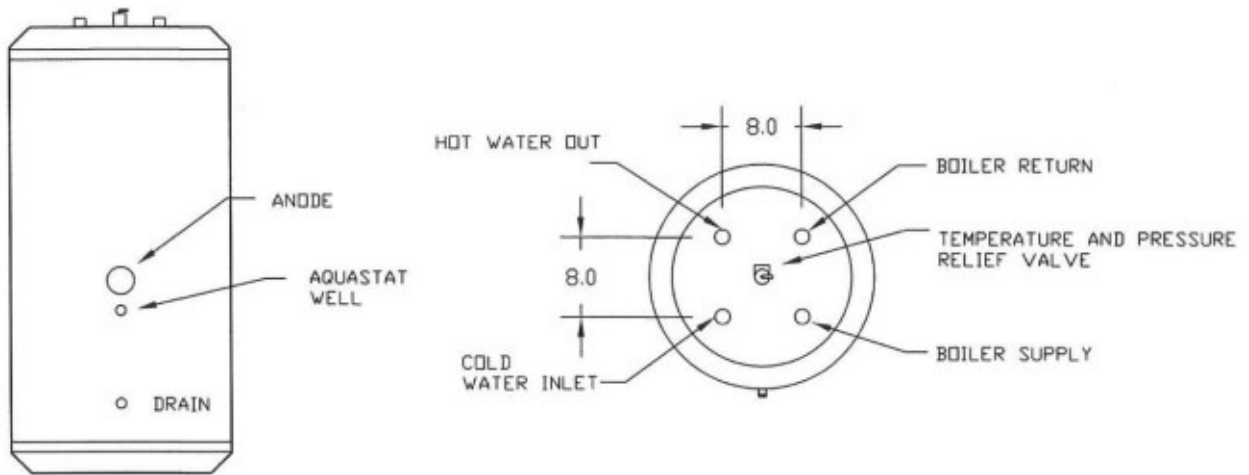

HOC UNITS

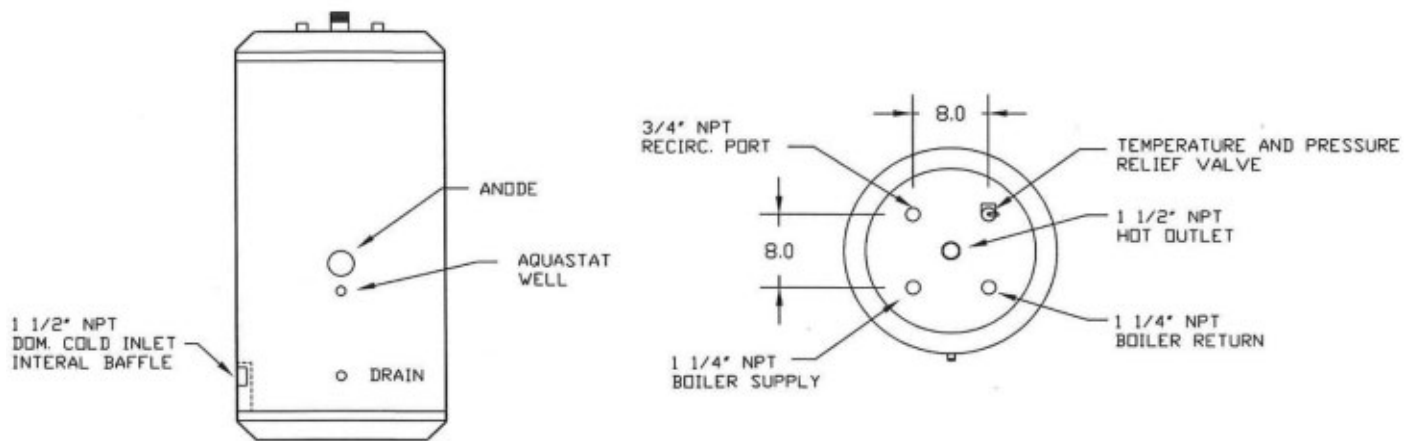

XHOC EXTRA HIGH OUTPUT UNITS

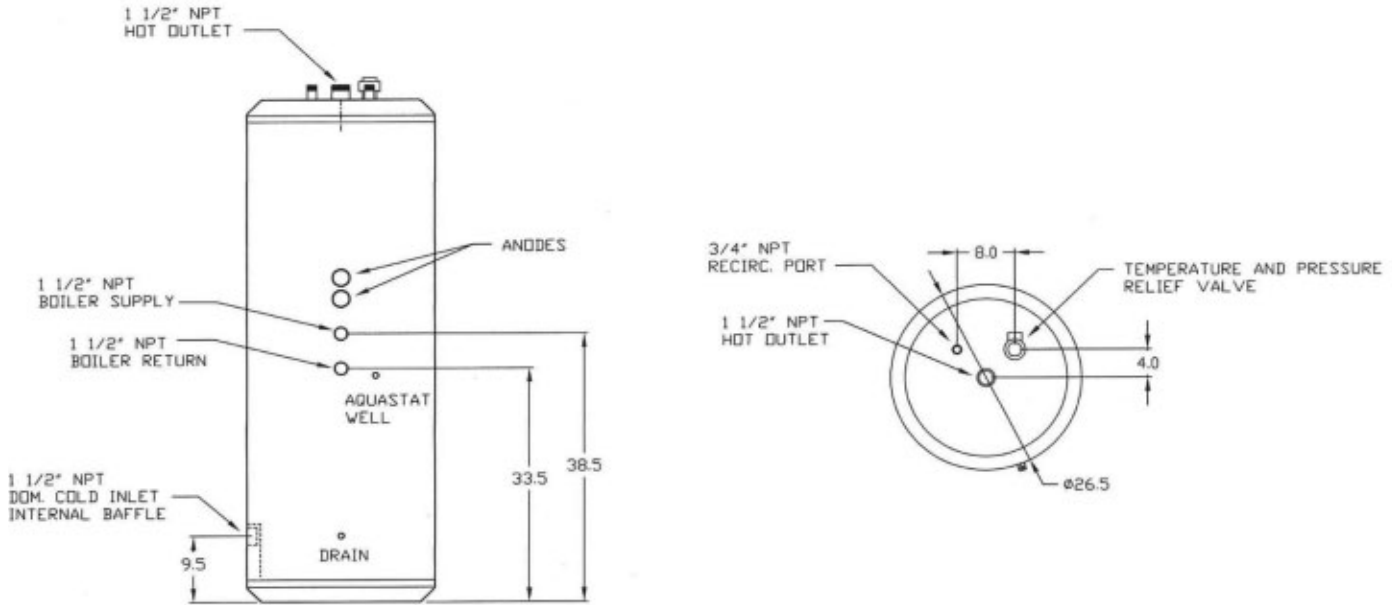

XHOC HIGH OUTPUT INDIRECTS
 MODEL 115-XHOC - HEIGHT = 74" - 115 GAL.
 MODEL 85-XHOC - HEIGHT = 64" - 86 GAL.

COLD AND HOT DOMESTIC - 1 1/2" NPT CONNECTIONS
 COIL SUPPLY AND RETURN - 1 1/2" NPT CONNECTIONS

TABLE 1- Dimensions and Capacities

Model	Storage Volume	Coil Heating Surface	Dimensions (Inches)		Piping Connections N.P.T		Max. Tank Working Pressure	Max. Coil Working Pressure	Approx. shipping Wt.
	Gals.	Sq. Ft.	Ht.	Dia.	Domestic Water In/Out	Boiler Water In/Out	(psi)	(psi)	Lbs.
H20I30	30	7.3	34.0	23.5	3/4	1	150	90	85
H20I40	40	7.7	44.0	23.5	3/4	1	150	90	100
H20I40L	42	7.4	36.0	28.0	3/4	1	150	90	100
H20I50	50	8.2	54.0	23.5	3/4	1	150	90	110
H20I60	60	8.6	62.0	23.5	3/4	1	150	90	125
H20I60L	60	7.7	46.0	28.0	3/4	1	150	90	120
H20I80	80	8.2	56.0	28.0	1	1	150	90	140
H20I115	115	9.1	74.0	28.0	1	1	150	90	175
High Output Units									
H20I60HO	60	15.1	62.0	23.5	1	1	150	90	145
H20I80HO	80	14.8	56.0	28.0	1	1	150	90	155
H20I8HOC	80	14.8	56.0	28.0	1½	1¼	150	90	155
H20I115HO	115	15.6	74.0	28.0	1	1	150	90	190
H20I115HOC	115	15.6	74.0	28.0	1½	1¼	150	90	190
Extra High Output Units 85-XHO and 115-XHO									
H20I85XHOC	87	28.7	64.0	28.0	1½	1½	150	90	215
H20I115XHOC	115	28.7	74.0	28.0	1½	1½	150	90	240

Table 2 - 200 deg F Boiler Supply Ratings

Model	Max. First Hour Rating		Continuous Rating		Boiler Output Needed	Boiler Water Flow Through Coil	Pressure Drop Through Coil
	Gal/Hr. @		Gal/Hr @		(BTU/Hr)	Gal/Min	(Ft. Water)
	140 F	115 F	140 F	115 F			
H2O130	202	269	175	242	131,250	14.0	5.3
H2O140	221	292	185	256	138,670	14.0	5.7
H2O140L	212	251	176	215	132,000	14.0	5.3
H2O150	223	291	178	246	133,280	14.0	6.0
H2O160	262	342	208	288	155,700	14.0	6.2
H2O160L	239	310	185	256	138,570	14.0	5.7
H2O180	271	248	199	276	149,390	14.0	6.0
H2O1115	324	409	221	306	165,750	14.0	6.6
High Output Units 60-HO, 80-HO, and 15-HO							
H2O160HO	406	541	352	478	263,600	14.0	10.1
H2O180HO	418	551	346	479	259,340	14.0	9.9
H2O180HOC	442	584	370	512	277,070	21.0	10.5
H2O115HO	467	607	364	504	273,100	14.0	15.8
H2O1115HOC	479	623	376	520	281,800	21.0	16.7
Extra High Output Units 85-XHO and 115-XHO							
H2O185XHOC	738	992	660	914	495,000	28.0	13.0
H2O1115XHOC	763	1017	660	914	495,000	28.0	13.0

Table 3 - 180 deg F Boiler Supply Ratings

Model	Max. First Hour Rating		Continuous Rating		Boiler Output Needed	Boiler Water Flow Through Coil	Pressure Drop Through Coil
	Gal/Hr. @		Gal/Hr @		(BTU/Hr)	Gal/Min	(Ft. Water)
	140 F	115 F	140 F	115 F			
H2O130	176	233	149	206	111,560	14.0	5.3
H2O140	193	254	157	218	117,870	14.0	5.7
H2O140L	186	251	150	215	223,300	14.0	5.3
H2O150	196	254	151	209	113,290	14.0	6.0
H2O160	231	298	177	244	132,340	14.0	6.2
H2O160L	211	272	157	218	117,785	14.0	5.7
H2O180	241	306	169	234	126,980	14.0	6.0
H2O1115	291	363	188	260	140,890	14.0	6.6
High Output Units 60-HO, 80-HO, and 15-HO							
H2O160HO	353	468	299	414	224,200	14.0	10.1
H2O180HO	366	479	294	407	220,440	14.0	9.9
H2O180HOC	386	507	314	435	235,510	21.0	10.5
H2O115HO	413	532	310	429	232,135	14.0	15.8
H2O1115HOC	423	545	320	442	239,530	21.0	16.7
Extra High Output Units 85-XHO and 115-XHO							
H2O185XHOC	649	868	571	790	428,000	28.0	13.0
H2O1115XHOC	674	893	571	790	428,000	28.0	13.0

NOTE: All ratings are based on 50 deg. F cold water inlet.

3. Circulator Sizing.

Refer to Tables 2 and 3 for the minimum flow through the water heater coil and the pressure drop at minimum flow. Calculate the pressure drop across all piping and fittings connected to the water heater zone. Be sure to include all zone valves, check valves, and shut-off valves. It is recommended that the water heater zone be piped with 1" pipe around the entire loop on typical residential sites.

A. System Zone Control

The water heater must be installed as a separate zone from the space heating system. The water heating zone's piping and circulator must be sized for the minimum flow rate with all the zones in use and a maximum flow with only the water heater in use. Best performance is normally achieved using zone control with circulators.

The three most common systems are:

1. Zone Circulators- Space heating zones use a circulator for each zone. The water heater is controlled with an additional circulator.
2. Hybrid System- Space heating zones use zone valves for each zone. The water heater is controlled with an additional circulator.
3. Zone Valves – Space heating zones use zone valves for each zone. The water heater is controlled with an additional zone valve. Select a valve with a low pressure drop, and assure minimum flow with adequate pipe sizing.

B. Priority or Non-Priority for Hot Water

1. **Option 1 – Priority.** The demand for space heating is interrupted until the hot water demand is satisfied. This option provides the maximum delivery of hot water.

Priority is recommended when:

- A. The boiler output is less than 100,000 Btu per hour, or
- B. The boiler output required to satisfy the hot water demand is more than 50% of the boiler output needed to satisfy the space heating demand, or
- C. When an interruption in space heating can be tolerated during long domestic hot water draws.

In most cases the delay in space heating will not be noticed because of the rapid recovery of the water heater. It must be recognized however that certain water heater malfunctions, such as a failed thermostat or circulator, could delay space heating indefinitely.

2. **Option 2 – Non-Priority.** The boiler output is divided between space heating and water heating. Heating of domestic hot water can be reduced during simultaneous space and water heating demands. The amount of reduction depends on the boiler output, the number of space heating zones calling, and the amount of boiler water flow split between the space heating and zones and the water heater zone.

C. Locating the water heater.

Water heater should be located in an area where water leakage from the tank or connections will not result in damage to areas adjacent to the water heater or to lower floors of the structure. When such a location can not be avoided, a suitable drain pan must be installed under the water heater, and the drain pan must be connected to a drain.

Water heater should be installed as close to the boiler as is practical for easy access for service. Unit is designed for installation on combustible flooring and in alcoves, closets, etc.

The minimum clearances from combustible surfaces are:

- Bottom-----0"
- Left, right, and rear sides -- 1"
- Front-----1"
- Top-----6"

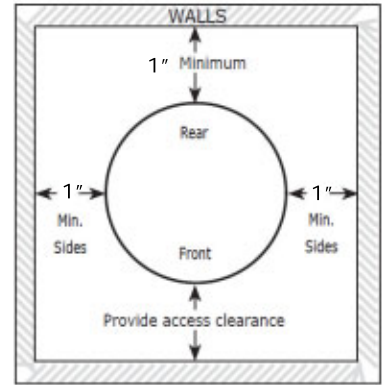
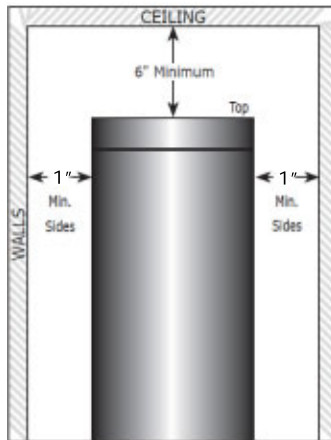

Front View

Top View

The minimum clearances for service are:

- Bottom-----0"
- Left, right, and rear sides -- 3"
- Front-----30"
- Top-----6"

D. Additional components

1. Shut-off valves. Allows the isolation of the water heater from the boiler system during service.
2. Unions. Allows for easy locating or removal. Use dielectric unions or couplings to protect hot and cold water fittings from corrosion when connecting dissimilar materials such as copper and galvanized pipe.
3. Vacuum breaker. Protects the water heater from collapse if a hot tank is valved off to service other components in the system. Required for Commonwealth of Massachusetts.
4. Thermal expansion tank. If the water heater is installed in a closed water supply system, such as a system having a back flow preventer in the cold water supply line, the installation of a thermal expansion tank is required.
5. Water hammer arrester. Dishwashers, clothes washers, and fast-closing positive shutoff valves incorporated in the system all contribute to creating water hammer. Install a water hammer arrester to prevent damage to pipes and appliances. See control manufacturer's instructions for application and installation.
6. Backflow preventer. Protects potable water supplies from contamination due to backflow. Required for Commonwealth of Massachusetts.

E. Removing the Existing Domestic Water Heating System

1. External Tankless Heater- Disconnect all lines to the boiler and plug the boiler fittings. Disconnect the external heater from the boiler piping, and the domestic piping systems.
2. Internal Tankless Heaters- Disconnect the domestic piping. Do not plug the cold water or the hot water fittings in the internal tankless coil. Leave the coil in the boiler with the cold and hot water fittings open to prevent pressure build-up in the coil.

NOTICE

For California installation this water heater must be braced, anchored, or strapped to avoid falling or moving during an earthquake. See instructions for correct installation procedures. Instructions may be obtained from California Office of the State Architect.

F. Water Quality

Improper water quality will reduce the expected life of the water heater. Hard water, sediment, high or low Ph, and high levels of chlorides in the domestic water should be avoided. Sediment and hard water will eventually coat the heating coil inside the water heater and reduce the rate of hot water production and may, eventually cause a failure. High or low Ph and/or high chloride concentrations will cause corrosion and eventually failure. A filter is strongly recommended where sediment is present in the water. A water softening system is recommended for areas with hard water.

In an area where the water quality is not known, a water quality test should be performed.

WARNING:

Do not operate the water heaters in areas where the Ph is above 8.0 or below 6.0, and/or with chloride concentrations greater than 100 parts per million (ppm). ECR's standard warranty does not cover problems caused by improper water Ph or excessive levels of chlorides.

NOTICE

Damage to tanks caused by improper water quality is not covered under the warranty.

III. Piping

A. Domestic water piping. See Figure 1.

1. Shut off the cold water supply at the main shutoff valve.
Open one or more faucets to relieve the pressure. Open the system drain, leaving the faucets open.
Drain the domestic water system.
2. Position the water heater in the final location.
3. Connect the cold water supply piping.
 - Install piping onto cold inlet connection.
 - Connect to cold water supply connection using a union, a heat trap, a shut-off valve, a vacuum breaker, an expansion tank (where required), and a filter (recommended to prevent sediment buildup).

NOTICE

If installing on a city supply, a properly sized thermal expansion tank is required and should be installed in accordance with the product installation manual.

If a water heater is installed in a closed water supply system, such as one having a backflow preventer in the cold water supply, a check valve in the cold water supply, or a pressure reducing valve in the cold water supply means shall be provided to control thermal expansion.

The appliance, when installed, must be grounded in accordance with the local codes, or in the absence of local codes, with the National Electrical Code, ANSI/NFPA 70.

WARNING

If this product is connected to a cold water supply line that has a check valve, a backflow preventer, a pressure reducing valve, or a check valve in the water meter, it is a requirement that a properly sized thermal expansion tank be installed in the cold water inlet line. *There will be no warranty on applications where there is no pressure control.*

4. Connect the domestic hot water piping.
Install piping on to hot water supply connection using a union, a heat trap, a vacuum breaker, and a shut-off valve.

- Pipe the relief valve discharge so that the discharge from the valve will exit only within 6 inches above, or at any distance below, the structural floor, and cannot contact any live electrical part. The discharge opening must not be blocked or reduced in size under any circumstances.

WARNING

Install a discharge line so that water discharged from the temperature and pressure relief valve will exit within six (6) inches above, or any distance below, the structural floor and cannot contact any live electrical part. The discharge line is to be installed to allow for complete drainage of both the temperature and pressure relief valve and the discharge line. The discharge opening must not be subjected to blockage or freezing.

DO NOT thread, plug, or cap the discharge line. It is recommended that a minimum clearance of four (4) inches be provided on the side of the water heater for servicing and maintenance of the combination temperature and pressure relief valve.

Do not place a valve between the combination temperature and pressure relief valve and the tank!

- Fill the water heater tank.
Open all faucets to allow air to purge from the tank and piping. Remove screens on faucets.
Open domestic hot water shut-off valve.
Open cold water inlet shut-off valve.
Purge all of the air from the domestic water system. Allow water to run so the tank is completely purged of any debris. Run the water long enough to change at least five tank volume changes. Close all faucets. Reinstall all of the screens in the faucets.
Check the system for leaks. Repair as required.

B. Water boiler piping. See Figures 3 and 4.

- Determine where the boiler, the space heating, and the water heater connections should be made based on the type of piping system that is either in place, or is to be installed for a new hydronic system installation. See Figure 3, Boiler Water Piping with Zone Circulators, and Figure 4, Boiler Water Piping with Zone Valves.
- It is recommended that 1" pipe and 1" zone valves be used on the water heater zone on residential site and 1¼" and 1½" pipe be used on High Output units on commercial sites.

Zone Circulator System

For space heating systems that use Zone Circulators, refer to Figure 3. The water heater connection labeled "BOILER SUPPLY" should be piped to the boiler supply piping after the air purger and before the space heating takeoffs. Mount the water heater circulator as close as possible to the water heater, and make sure the flow arrow points toward the water heater. The use of shut-off valves is recommended for future service convenience.

The water heater connection labeled "BOILER RETURN" should be piped to the boiler return piping as close to the boiler as possible and after any flow control or check valves in the space heating return piping. The use of a union and a shut-off valve is recommended. The use of a check valve is required to prevent back flow through the water heater during operation of the space heating system.

Zone Valve System

For a space heating system that uses Zone Valves, refer to Figure 4. The water heater connection labeled "BOILER SUPPLY" should be piped to the boiler supply piping after the air purger and before the space heating circulator. Mount the water heater circulator as close as possible to the water heater, and make sure the flow arrow points toward the water heater. The use of a shut-off valve is recommended for future service convenience.

The water heater connection labeled "BOILER RETURN" should be piped to the boiler return piping as close to the boiler as possible and after any flow control or check valves in the space heating return piping. The use of a union and a shut-off valve is recommended. The use of a check valve is required to prevent back flow through the water heater during operation of the space heating system.

NOTICE

Figures 1, 2, 3 and 4 are meant to illustrate system piping only. The Installer is responsible for conforming to the Local Codes. In Massachusetts, you must install a vacuum relief valve per 248 CMR. See local code requirements.

Figure 1 - Domestic Water Piping

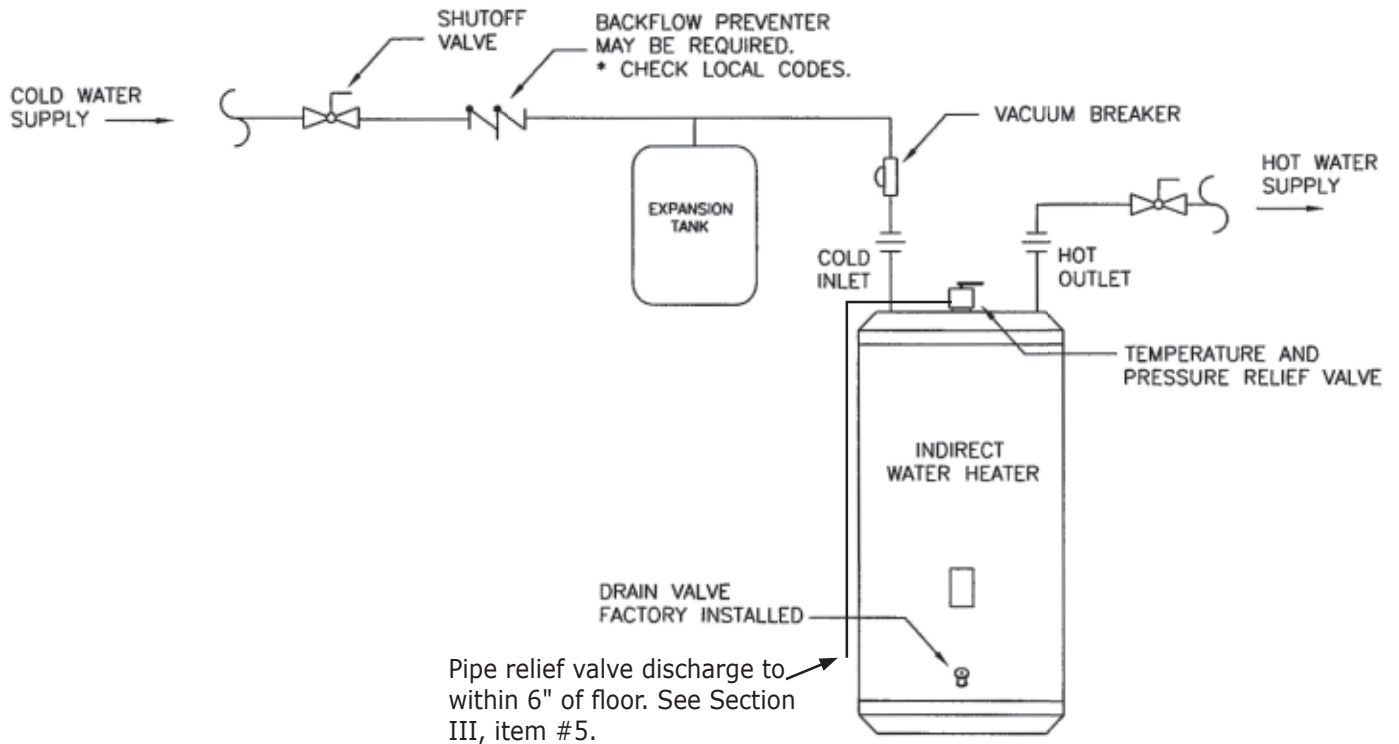

Figure 2 - Typical Mixing Valve Install

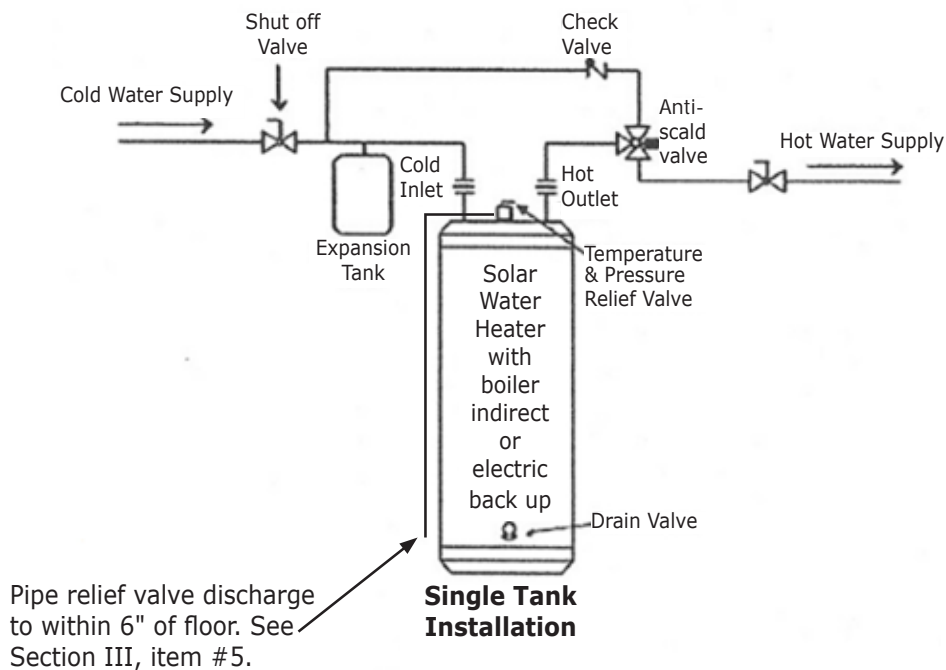

Figure 3 - Boiler Water Piping with Zone Circulators

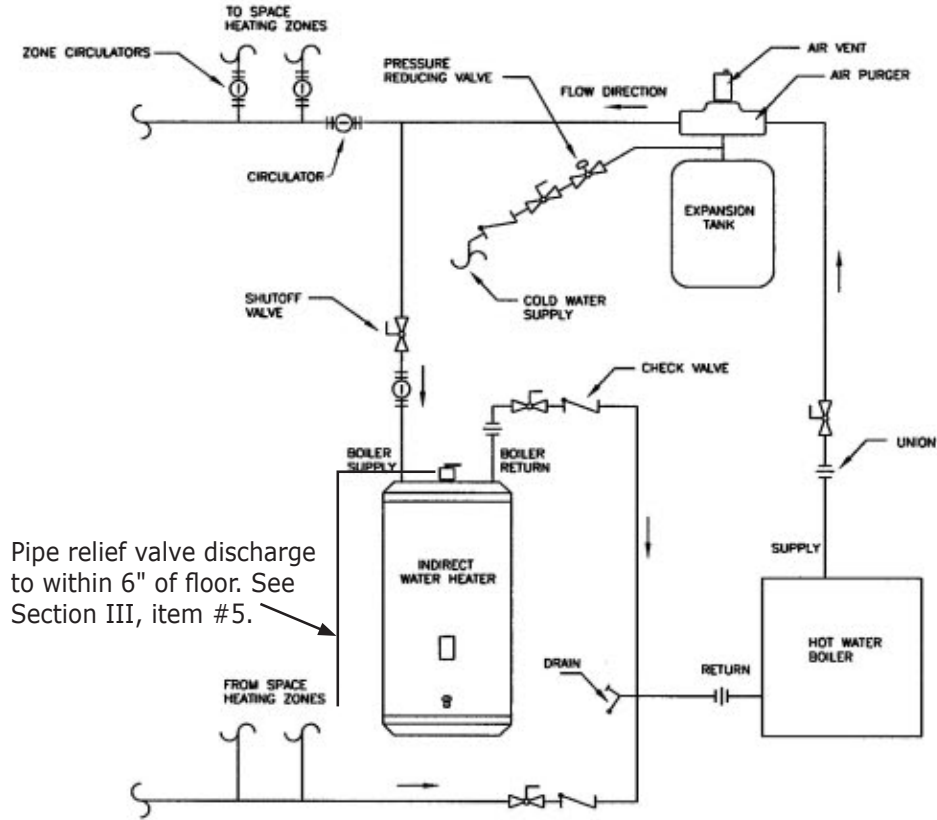
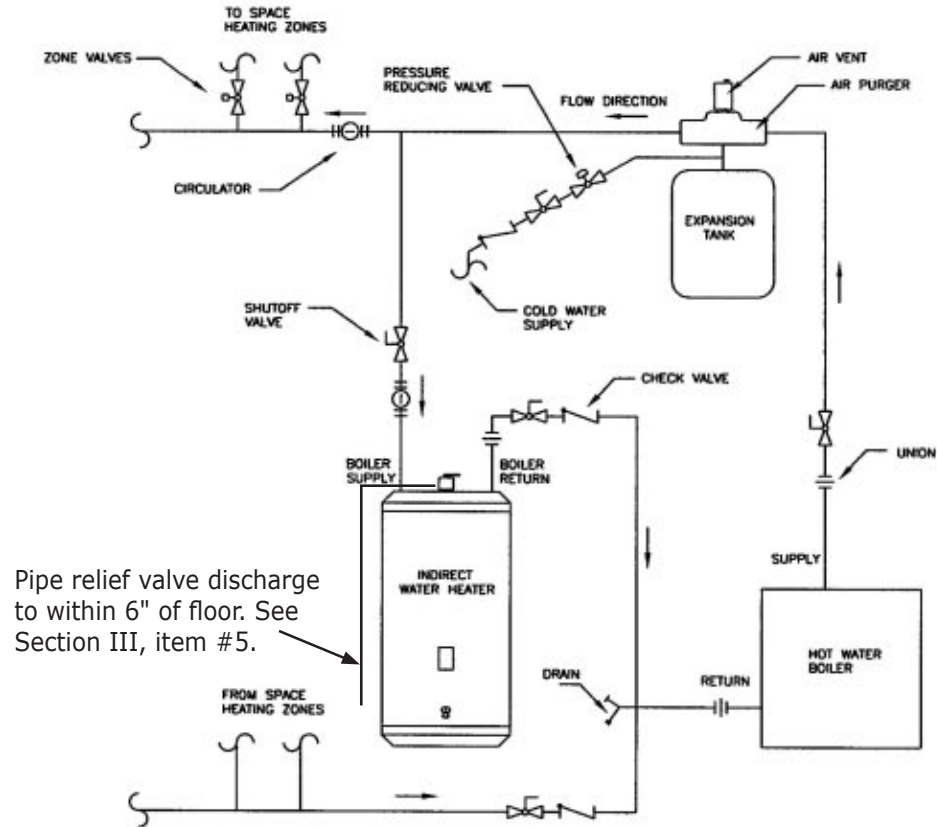

Figure 4 - Boiler Water Piping with Zone Valves



IV. Electrical

1. Install electric wiring and grounding in accordance with the National Electrical code and local regulations.
2. All water heaters are supplied with a thermostat.
3. Refer to schematics for separate circulator wiring.
Refer to schematics for zone valve wiring.
Reference should be made to the Installation Manual for the boiler as well.

V. Operation

Startup

After the water heater has been plumbed and wired, and the boiler water piping is purged of air, the water heater is ready to be started.

1. Follow the boiler installation instructions to place the boiler in operation.
2. The tank thermostat is factory pre-set to 125 degrees F and will call for heat if the water in the tank is lower than 125.
3. On a call for heat, the tank thermostat contacts close to start the water heater zone circulator and the boiler.
4. After the tank has reached the temperature setting, the tank thermostat opens and de-energizes the circulator and the boiler. If there is a call for space heating, the boiler will continue to run until the room thermostats are satisfied.

WARNING

This water heater can deliver scalding temperature water at any faucet in the system. Be careful when using hot water to avoid scalding injury. By setting the thermostat on this water heater to obtain an increased water temperature, you create the potential for scald injury. To protect against injury, you should install an ASSE approved mixing valve (a device to limit the temperature of water to protect against scald injury via mixing hot and cold water supply) in the water system. This valve will reduce point of discharge temperature in branch supply lines. Such valves are available from a local plumbing supplier. Please consult with a plumbing professional.

Temperature Adjustment

The tank thermostat controls the maximum water temperature in the water heater. If it is set too high, the resulting hot water can cause painful scalding with possible serious and permanent injury. The temperature at which this occurs varies with a person's age, and the length of time in contact with the hot water. The slower response time of infants, older, or handicapped people increases the hazard for them.

It is recommended that the thermostat be set for the lowest possible temperature that satisfies your needs. This will also provide you with the lowest energy consumption and cost.

Check the water temperature at a hot water faucet soon after the tank thermostat has satisfied, and the circulator and the boiler have turned off. Adjust as needed.

Lowering the thermostat setting will not have an immediate effect on the water temperature because the stored water will have to be used and the thermostat must go through the cycle of heating cold water and satisfying at the new, lower temperature. Additional temperature checks should follow the completion of a heating cycle. Further adjustments may be required after you have used the water heater.

The table below details the approximate relationship of water temperature and time with regard to scald injury and may be used as a guide in determining the safest water temperature for your applications.

Approximate Time/Temperature Relationships in Scalds	
120°F (52°C)	More than 5 Minutes
125°F (52°C)	1½ to 2 Minutes
130°F (54°C)	About 30 Seconds
135°F (57°C)	About 10 Seconds
140°F (60°C)	Less Than 5 Seconds
145°F (63°C)	Less Than 3 Seconds
150°F (66°C)	About 1½ Seconds
155°F (68°C)	About 1 Second

The scald label show to the right can be found on all Indirect Water Heaters and Storage tanks. Take note and use caution when adjusting the temperature settings with your water system. Be sure to always feel the water before bathing or showering, especially when drawing a bath for an infant or elder.



Hot Water Can Scald!

Water heated to temperature for clothes washing, dish washing and other sanitizing needs can scald and cause permanent injury.

Children, elderly, and infirm or physically handicapped persons are more likely to be permanently injured by hot water. Never leave them unattended in bathtub or shower. Never allow small children to use a hot watertap or draw their own bath.

If anyone using hot water in the building fits the above description, or if state laws or local codes require certain water temperatures at hot water taps, you must take special precautions:

- Use lowest possible temperature setting.
- Install some type of tempering device, such as an automatic mixing valve, at hot water tap or water heater. Automatic mixing valve must be selected and installed according to manufacturer's recommendations and instructions.

Water passing out of drain valves may be extremely hot. To avoid injury:

- Make sure all connections are tight.
- Direct water flow away from any person.

WARNING

It is the responsibility of the installing contractor to see that all controls are correctly installed and are operating properly when the installation is complete.

DO NOT operate the water heater with jumpered or absent controls or safety devices.

DO NOT tamper with or alter the water heater and /or controls.

DO NOT operate the water heater if any external part has been under water. Immediately call a qualified service technician to inspect the appliance and to replace any part of the control system that is or had been under water.

DO NOT install this water heater on carpeting. This water heater is suitable for installation on combustible flooring.

DO NOT operate this water heater without first being certain it is filled with water.



Argo offers a broad line of controls for water heating and multiple zone boiler heating applications.

Please check out our web site at <http://www.argoindustries.com> for applications information and comprehensive wiring diagrams.

A typical wiring diagram is shown below. This is a multi-zone application using zone pumps with programmable domestic hot water priority using our ARM-4P Panel.

Product features include:

1. Built in transformer that will support up to 15 zones. Transformer has electronic fuse protection to prevent transformer overloading.
2. Data Port Terminal for easy connection to other Argo control products.
3. Expansion module plug-in allowing easy expansion to more zones.
4. Priority Zone Safety Timer. If the priority zone calls for more than 30 minutes the priority zone feature will turn off allowing all zones to operate independently preventing freeze ups if water heater has a problem.
5. Plug in replacement relays for long life and easy servicing with 1/3 HP pump motor ratings.

INDIRECT WATER TANK TO ARM-4P CONTROL

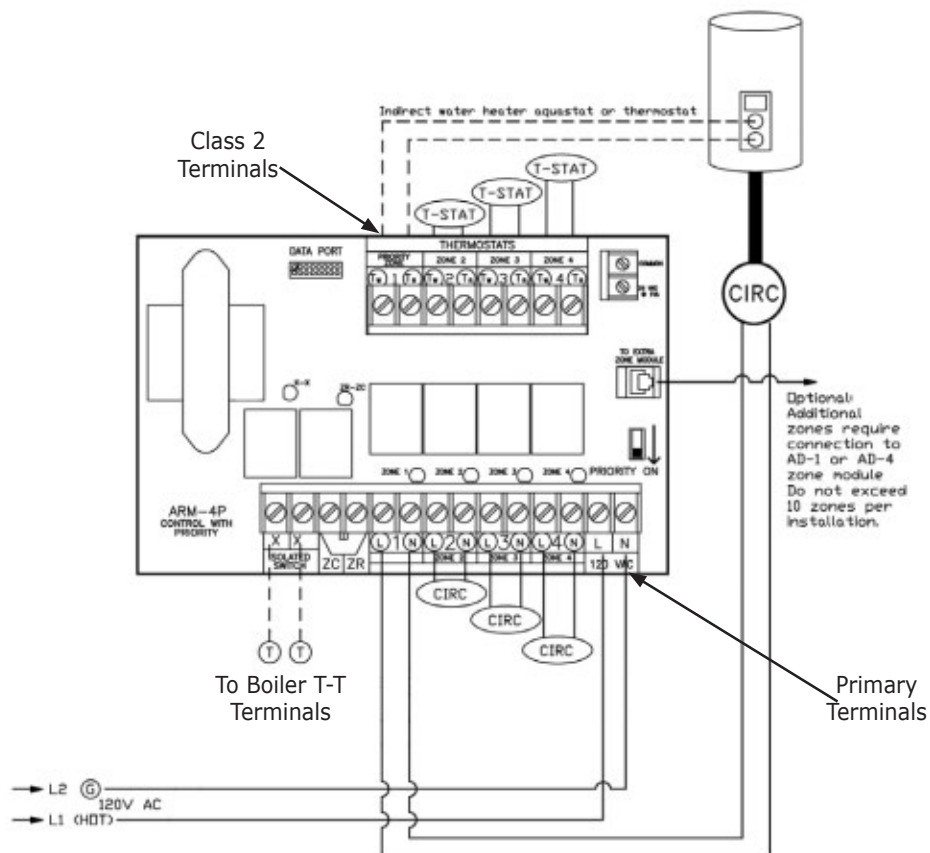

ZONE VALVE WIRING

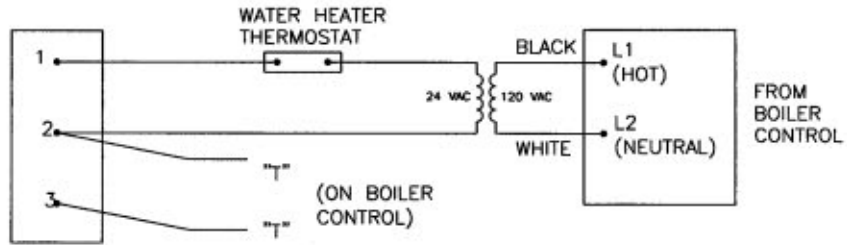

SCHEMATIC 4
3-WIRE ZONE VALVE

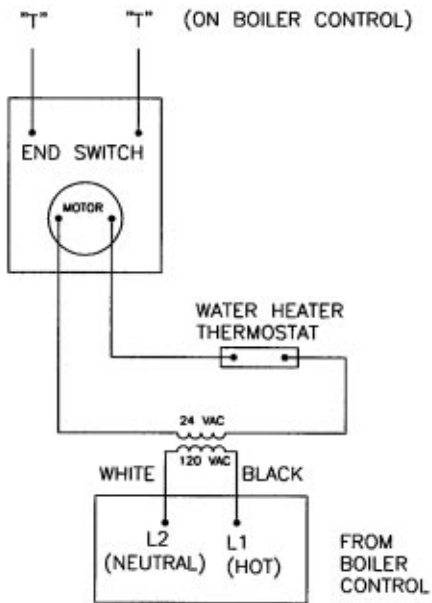

SCHEMATIC 5
4-WIRE ZONE VALVE WITH 24 VOLT MOTOR

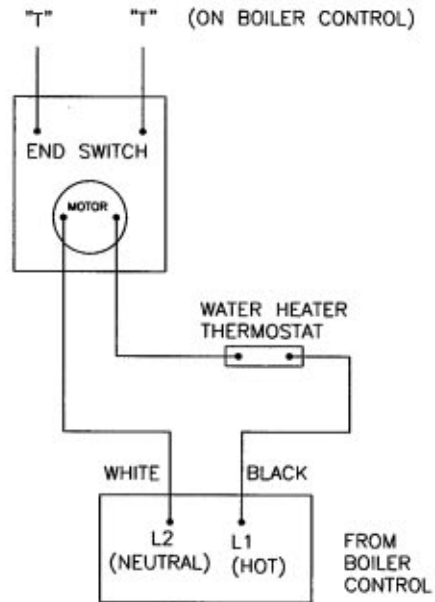

SCHEMATIC 6
4-WIRE ZONE VALVE WITH 120 VOLT MOTOR

VI. Maintenance

The water heater is intended to provide many years of reliable service. Components, such as thermostats and relief valves, may be subject to failures that require service. Depending on the quality of the water supply, sediment and/or scale may coat the heating coil in the tank and reduce hot water recovery rate. Failure to use the correct procedures or parts can result in unsafe operation.

The owner should arrange to have the following inspections and simple maintenance procedures done at the suggested frequencies.

1. Boiler and Domestic Water Piping (Annual)
Check all piping for signs of leakage at the joints, unions and shut-off valves. Repair as required.
2. Temperature and Pressure Relief Valve (Annual)
 - The temperature and pressure relief valve should be checked to ensure that it is in operating condition. To check the relief valve, lift the lever at the end of the valve several times. The valve should seat properly and operate freely. If water does not flow, remove and inspect for obstructions or corrosion. Replace with a new valve of the recommended capacity as necessary. Do not attempt to repair the valve, as this could result in improper operation and a tank explosion. In areas with poor water conditions, it may be necessary to inspect the temperature and pressure relief valve more often than once a year.

CAUTION

Before manually operating the valve, make sure that a drain line has been attached to the valve to direct the discharge to an open drain. Failure to take this precaution could mean contact with extremely hot water discharging from the valve during this checking operation.

If the temperature and pressure relief valve on the heater discharges periodically or continuously, it may be due to thermal expansion of water in a closed water supply system, or it may be due to a faulty relief valve. Thermal expansion is the normal response of water when it is heated. In a closed system, thermal expansion will cause the system pressure to build until the relief valve actuation pressure is equaled. Then the relief valve will open, allowing some water to escape, slightly lowering the pressure. Contact your water supplier or local plumbing inspector on how to control this situation.

3. Sediment (Annual except where harsh water quality may require more frequent service)
Depending on water conditions, a varying amount of sediment may collect in the tank. Levels requiring service are indicated by a small temperature difference between the boiler supply and return lines, and a reduced recovery rate. Repeated flushing usually clears such material. As a preventive measure, water should be drawn from the drain valve until it runs clear and the installation of a water filter should be considered.
4. Scale (Annual)
Hard water may cause scale buildup on the outside of the heating coil inside the tank. A water softener will prevent this problem. Symptoms are identical to sediment buildup. If repeated flushing does not resolve the problem, chemical cleaning may be required. Contact a qualified contractor.

5. Inspect Anode (annual)

- The purpose of the magnesium anode is to reduce the damaging effects of aggressive water on the water heater. Aggressive water will cause the anode(s) to erode. The anode(s) must be inspected at least annually to determine whether a new anode should be installed. Use anode replacement parts supplied by ECR only. ECR anodes are 1-1/4 NPT and are made with magnesium, brass, and stainless steel. There is no steel in a ECR anode. Severe or rapid deterioration of the anode indicates very aggressive water. If this occurs, have the water tested to verify whether it is within the limits outlined on page 11. Failure to inspect the anode regularly and replace if necessary could result in damage to the water heater. If this unit is installed and maintained according to the instructions and conditions in this manual, this product will last for a long time.
 1. Close domestic water isolation valves.
 2. Drain the water heater completely and allow it to cool off.
 3. Remove the anode cover on the front of the unit. See figures on pages 6 and 7. The temperature control can be turned to the side to allow easier access.
 4. After the water heater has drained and cooled, remove the anode using a 1³/₄" 6-point socket and a breaker bar.
 5. Inspect the anode and replace if needed. The anode should be replaced when more than 6" of core wire is exposed. The anode should be replaced with a ECR supplied anode only. See above. The brass hex on the anode is 1¹/₄ NPT and installs into a 1¹/₄ stainless half coupling on the shell of the tank. This part will need to be properly Teflon taped and coated with a quality Teflon based pipe sealant.
 6. Replace the inspection cover.
 7. Refill the water heater, and restore to operation.
 8. Verify operation of boiler and water heater.

VII. Troubleshooting

PROBLEM	CAUSE	SOLUTION
No hot water at faucets	Boiler does not operate.	Press reset button Check main cut-off switch Check fuses or breakers. Check power supply Check shaft coupling
	Circulator does not operate	Check shaft coupling
	Improper thermostat setting	Turn thermostat to a higher setting.
	Zone valve does not open	Check power supply and valve
	Electrical problem	Check fuses and replace. Check circuit breaker and reset. Check power supply
	Sediment and/or scale buildup	If boiler, circulator, and thermostat are operating properly, and the boiler is cycling on the high limit several times before the tank thermostat is satisfied, the coil may have a coating of sediment and/or scale.
	Clogged filter	Clean or replace filter.
Insufficient or runs out of hot water at the faucet	Thermostat setting too low.	Turn the thermostat to a higher setting.
	Undersized boiler with no priority to domestic water heating.	Rewire for priority.
	Peak draw of hot water is greater than the tank storage.	Determine peak usage and compare to tank volume.
	Sediment and/or scale buildup	Clean coil
	Faulty water heater thermostat	Replace thermostat
Water at faucet too hot	Thermostat set to high	Lower thermostat setting.
	Improper system plumbing	Compare plumbing to installation guide. Inspect check valves.
	Improper wiring.	Compare wiring to installation guide.
Boiler cycles more than 5 times per day in summer	Excessive demand	Reduce demand or consider larger boiler and/or water heater.
	Faulty thermostat	Replace thermostat
	Boiler high limit set to low	Increase boiler hi-limit setting
	Sediment and or scale buildup	Clean coil.

REPLACEMENT PARTS LIST

	Description	Part Number
1	Temperature and Pressure Relief Valve (for all models except XHOC)	240010926
2	Temperature and Pressure Relief Valve (for XHOC models only)	240010927
3	Aquastat Well, Stainless Steel	240009522
4	Aquastat	240009521
5	Drain Valve Nipple, 1/2" x 3 1/2" Stainless Steel	240010930
6	Drain Valve	240010928
7	Anode Rod	240010929

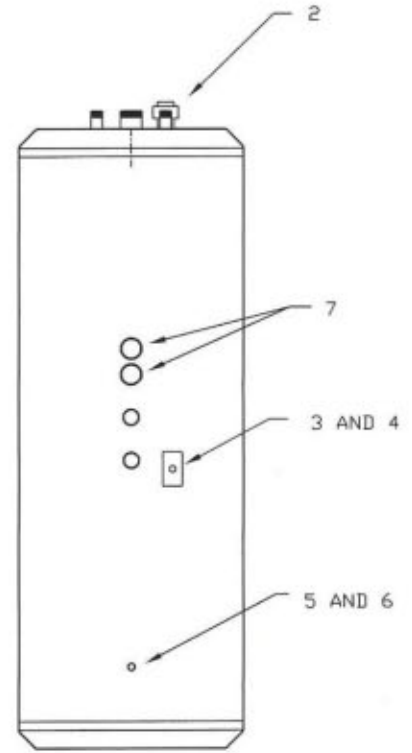

XHOC HIGH OUTPUT INDIRECTS

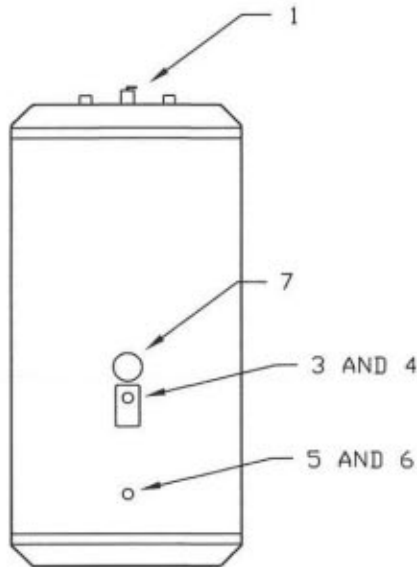

STANDARD AND HO UNITS

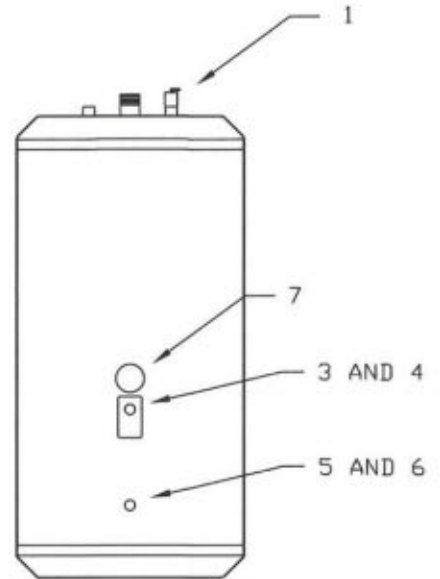

HO-C UNITS

ECR International, Inc. LIMITED WARRANTY INDIRECT WATER HEATERS & STORAGE TANKS

By this Limited Warranty ECR International, Inc. ("ECR") issues limited warranties from the date of original installation of the H₂O Indirect Water Heater or Storage Tank ("Product") to the person that purchased the new Product directly (a) from the ECR brand dealer; or (b) in the case of a newly constructed home, from the contractor who purchased such new Product directly from an ECR brand dealer or wholesaler for installation and use in the newly constructed home (such person in either case referred to hereinafter as the "Original Purchaser"), subject to the terms and conditions set forth below.

WARRANTY COVERAGE FOR RESIDENTIAL USAGE

The following limited warranty set forth in this section shall apply to only the original installation of the Product in a single-family dwelling used without interruption by the Original Purchaser as his or her primary residence ("Residential Application"). "Residential Application" shall also mean usage in a multiple family dwelling provided that the Product services only one (1) dwelling in such multiple family dwelling. The term "Residential Application" shall not include any usage of the Product above one hundred fifty (150) degrees Fahrenheit.

First Year

ECR warrants its Product used in Residential Applications to be free from defects in material and workmanship under normal usage and service for a period of one (1) year from the date of original installation. In the event that any component of the Product is found to be defective in material or workmanship during this one-year period, then ECR will repair or replace, at its option, the defective component.

Second Year through Lifetime

During the remaining lifetime of the Product, ECR will repair or replace, at its option, any component of the Product found to have a defect or malfunction that results in a water leak from the outer jacket, inner tank, or heat exchanger of the Product under normal usage and service.

If ECR is unable to repair or replace the Product component so as to repair the water leak from the outer jacket, inner tank, or heat exchanger of the Product, after a reasonable number of attempts, then ECR will provide at its option, either a replacement Product, or a full refund of the purchase price.

If at the time of the request for service, the Original Purchaser cannot provide a copy of the original sales receipt for the Product, or equivalent document, then the warranty period for the Product shall be ten (10) years from the date of manufacture of the Product.

WARRANTY COVERAGE FOR COMMERCIAL USAGE

The following limited warranty set forth in this section shall apply to only the original installation of the Product in a Commercial Application, used without interruption by the Original Purchaser. "Commercial Application" as used herein shall mean, any usage not falling within the above definition of Residential Application. The term "Commercial Application" shall include any usage of the Product above one hundred fifty (150) degrees Fahrenheit.

First Year

ECR warrants its Product used in Commercial Applications to be free from defects in material and workmanship under normal usage and service for a period of one (1) year from the date of original installation. In the event that any component of the Product is found to be defective in material or workmanship during this one-year period, then ECR will repair or replace, at its option, the defective component.

Second Year through Fifth Year

During the second through fifth year after the date of original installation, ECR will repair or replace, at its option, any component of the Product having a defect or malfunction that results in a water leak from the outer jacket, inner tank, and heat exchanger of the Product under normal usage and service.

If ECR is unable to repair or replace the Product component so as to repair the water leak from the outer jacket, inner tank, or heat exchanger of the Product, after a reasonable number of attempts, then ECR will provide at its option, either a replacement Product, or a full refund of the purchase price.

LIMITATIONS AND EXCLUSIONS

1. Under no circumstances will ECR be responsible for any other costs associated with rectifying the defective part or Product, including, without limitation, costs associated with removing and reinstalling the defective part or Product and/or its replacement part or Product, and all labor and material costs connected therewith, including, without limitation, costs associated with returning the defective part or Product to ECR.

2. This Limited Warranty will not be applicable if the Product is (a) used or operated at a pressure over or under its rated capacity; (b) installed for uses other than home heating; (c) not maintained in accordance with ECR's recommendation or accepted good practice as determined by industry standards; or (d) subjected to unauthorized alteration.

3. This Limited Warranty will not be applicable if the Product has been damaged as a result of being improperly installed, serviced or operated, including, without limitation, operated with insufficient water, allowed to freeze or subjected to flood conditions.

4. In order for this Limited Warranty to be effective (a) the Product must have been assembled in strict compliance with installation instructions furnished with the Product; and (b) the Product sections must not have been damaged during shipment and installation.

5. ECR shall not be liable for any damages, defaults or delays in performance under this Limited Warranty caused by (a) any contingency beyond its control, including, without limitation, a shortage or reduced supply of energy or raw materials, freezing, flood, fire, wind or lightning; (b) the failure of external wiring, piping, or other attachments and accessory products not integral with the Product; (c) installation, service or operation that is not in compliance with all applicable federal, state and provincial laws or regulations; (d) misapplication or the use of the Product for purposes other than for which it was designed; (e) the use of parts not supplied or designated by ECR; (f) failure to maintain the Product free of water sediments or scale deposits; (g) components of a Product which are not defective, but must be replaced during the warranty period as a result of reasonable wear and tear; (h) failure of a component, control or component part other than a component part manufactured solely by ECR; or (i) potable water with a Ph exceeding 8.0 or below 6.0, and/or chloride concentrations exceeding 80 parts per million (ppm).

6. This Limited Warranty in no way can be considered as a guarantee of workmanship of an installer or repairman connected with the installation or repair of the Product or as imposing on ECR liability of any nature for unsatisfactory performance as a result of faulty workmanship in the installation or service of the Product, which liability is hereby expressly disclaimed.

7. The furnishing of replacement parts under the terms of this Limited Warranty will apply to the original warranty period and will not serve to extend such period.

8. This Limited Warranty only applies to Products installed in the United States or Canada.

9. The remedy for breach of this Limited Warranty is expressly limited to the repair or replacement of any part found to be defective under conditions of normal use, unless otherwise specifically set forth herein, and the remedy for breach of this Limited Warranty, statutory duty or by reason of tort (including, without limitation, negligence) does not extend to liability for incidental, special or consequential damages or losses, such as loss for the use of the material, inconvenience or loss of time. The maximum liability of ECR in connection with the sale of the Product shall not in any case exceed the price of the part claimed to be defective, or the price of the Product if the entire Product is claimed to be defective. This Limited Warranty is the complete and exclusive statement of warranty terms in regards to the Product.

10. FOR ALL SALES NOT SUBJECT TO THE MAGNUSON-MOSS WARRANTY ACT THE FOREGOING WARRANTIES ARE EXCLUSIVE AND ARE GIVEN AND ACCEPTED IN LIEU OF ANY AND ALL OTHER WARRANTIES, EXPRESS OR IMPLIED, INCLUDING, WITHOUT LIMITATION, THE IMPLIED WARRANTIES OF MERCHANTABILITY AND FITNESS FOR PARTICULAR PURPOSE. FOR ALL OTHER SALES, ALL IMPLIED WARRANTIES OF MERCHANTABILITY AND/OR FITNESS FOR ANY PARTICULAR PURPOSE ARE LIMITED IN DURATION TO THE PERIOD OF THIS LIMITED WARRANTY.

PLEASE NOTE: Some states, provinces and territories do not allow the exclusion or limitation of incidental or consequential damages, or limitations on how long an implied warranty lasts, so the above limitations and exclusions may not apply to you.

MISCELLANEOUS

1. The Magnuson-Moss Warranty Act applies to "consumer" sales as contrasted with "commercial" sales. A consumer sale is one to a buyer for personal, family or household purposes and not for the purpose of resale.

2. If any provision of this Limited Warranty shall be determined to be illegal, unconscionable or unenforceable, all other terms and provisions hereof shall nevertheless remain effective and shall be enforced to the fullest extent permitted by law. The warranties made under this Limited Warranty are exclusive and may not be altered, enlarged or changed by a distributor, dealer, or other person whatsoever, other than pursuant to a written agreement executed by a duly authorized officer of ECR.

3. This Limited Warranty is nontransferable and shall be for the benefit of the Original Purchaser of the Product only.

4. This Limited Warranty gives the Original Purchaser only specific legal rights and you may have other legal rights which vary from state-to-state.

PROCEDURE FOR OBTAINING WARRANTY SERVICE

1. At the time a claim is filed under this Limited Warranty the Original Purchaser must present a copy of the original sales receipt, and a deed, utility bill, or equivalent document evidencing both ownership of the Product and installation in the dwelling or commercial property owned by the Original Purchaser. With regard to claims made by an Original Purchaser used in a Commercial Application, in no event shall notification of a service request be received later than five (5) years from the date of original installation.

2. For prompt warranty service, notify the installer who, in turn, will notify the ECR distributor from whom such distributor purchased the Product. If this action does not result in warranty service, the Original Purchaser or installer should contact ECR Customer Service (see contact information below), giving full particulars in support of the claim. Alleged defective part or parts must be returned through trade channels in accordance with ECR's procedure currently in force for handling returned goods for the purpose of inspection or determining the cause of failure. ECR will furnish the new part(s) to an authorized ECR distributor who, in turn, will furnish the part(s) to the heating contractor who installed the Product.

ECR International, Inc.
2201 Dwyer Avenue
Utica, New York 13504-4729
Ph: 315/797-1310
Customer Service Fax: 315/724-9319
E-Mail: info@ecrinternational.com

PN 240009217 Rev. A 10/11

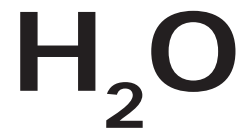

ECR International, Inc
2201 Dwyer Avenue, Utica NY 13504-4729

web site: www.ecrinternational.com