

D247

GAS FIRED BOILERS

- Natural Gas
- Water or Steam



Dunkirk[®] 
America's Hottest Boiler Value!

An ISO 9001-2000 Certified Company

D247 SERIES

NATURAL GAS-FIRED BOILERS - WATER OR STEAM

80.0% Combustion Efficiency

The D247 Series Boiler by Dunkirk meets the heating needs of today's commercial facilities including apartment buildings, schools, churches, office buildings and factories. Manufactured in 28 sizes from 300,000 to 3 million btuh the D247 can adapt to almost any application... and with superior reliability and efficiency it is one of America's Hottest Boiler Values.

Modular Efficiency

Since bases and draft hoods are produced in three modular sizes, the D247 is field assembled using a combination of modules to meet specific capacities. Water boilers can be **Stage Fired** by utilizing a sequencing control with outdoor reset* for maximum efficiency.

CSD1

D247 boilers can comply to **CSD1** standards by utilizing the CSD1 option. The increased number of controls and safety devices allow the boiler to meet, where required, public building codes.

Cast Iron Sections & Push Nipples

Dunkirk utilizes cast iron to construct the boiler's heat exchanger to provide heat transfer, reliability and strength. Since like materials expand and contract in the same proportion during heating and cooling, cast iron push nipples and sections produce stronger, more water-tight seals than steel push nipples or rubber gaskets.

Easy Installation

The D247's pre-assembled bases and section by section design make it easy to install and maneuver through small doorways. Its compact design weighs less and requires up to 25% less space than competitive models.

Easy Access & Maintenance

The D247's draft hood allows for easy cleaning or inspection of flueways. Front Access doors make combustion chambers and boiler sections easily accessible. Controls are readily available, making Dunkirk Boilers easy to service.

Dunkirk Quality

Since 1928, American-made Dunkirk Boilers have been leading the industry in value and reliability with innovative designs and premium quality components. Assured performance has placed Dunkirk quality at the top in trusted reliability (99.91%*). This boiler is certified by CSA in the United States; heat exchangers by ASME; and efficiency ratings by the Hydronics Institute.



*Most commercial boilers are "all-on" or "all-off" but the D247 allows you to match the heating demand of the day by step-firing bases and maximize efficiency.

D247 STANDARD EQUIPMENT

ELECTRONIC IGNITION BASE STANDARD EQUIPMENT

- Base ■ Fire Door ■ Burner Orifice ■ Manifold ■ Main and Pilot Burner
- Electronic Pilot Gas Valve ■ Intermittent Pilot Module ■ High Gas Pressure Switch

D247 Series Boiler Bases are preassembled at the factory with burner manifold, burner orifices, gas valves, electronic ignition and pilot installed, ready for field installation of the pre-tested boiler sections and appropriate packages.

Water Trim Package

- Limit Control (two required on units 2,500,000 BTU and larger)
- Pressure Temperature Gauge
- Relief Valve
- Drain Valve
- Complete Jacket Assembly

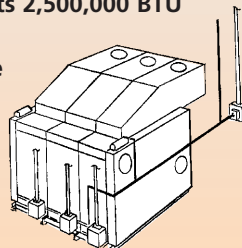

Steam Trim Package

- Low Water Cut-Off
- Glass Gauge Set
- Pop Safety Valve
- Steam Gauge
- Pressure Limit
- Drain Valve
- Complete Jacket Assembly

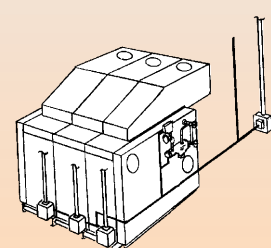

FEATURES & BENEFITS

Space Savings

Low profile and compact design provides commercial heating capacity within constrained areas.

Electronic Ignition

Electronic ignition automatically lights the pilot only when needed, eliminating fuel waste.

Modular Combination Bases

Available in 300, 400 and 500 MBH, bases are bolted together using a combination of modules to meet specific heating capacities.

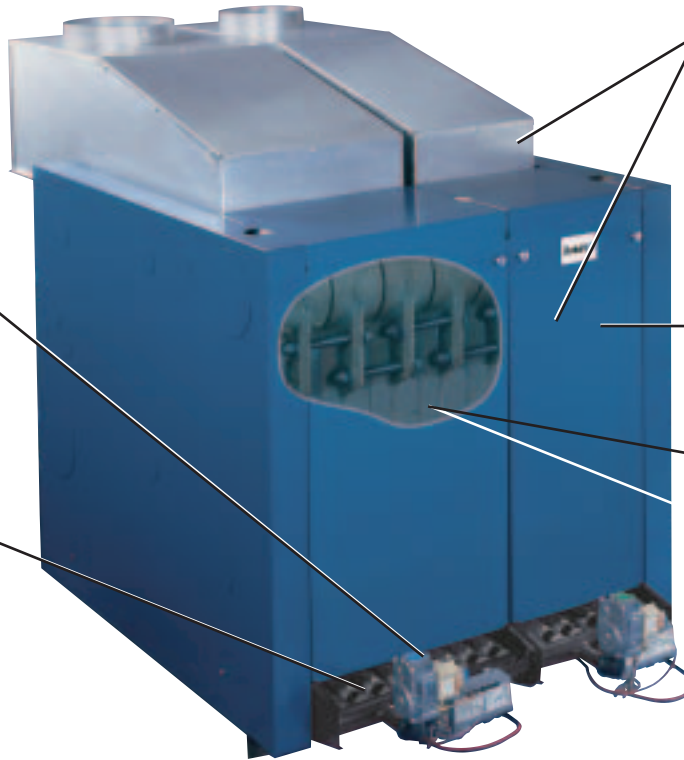

Easy Access & Maintenance

Draft Hoods allow for easy cleaning or inspection of flueways. Front doors make combustion chambers and sections easily accessible.

Baked Enamel Steel Jacket

Factory installed insulation keeps off-cycle heat losses to a minimum in an attractive and compact package

Cast Iron Quality

Provides effective heat transfer, reliability and strength

Easy Installation

The D247 is delivered in sections with factory complete bases and fuel trains, and then assembled on site. All sizes of boilers are installed the same way, aiding installer familiarity.

D247 SERIES DIMENSIONS IN INCHES

Boiler Model Number	Assembled Boiler Unit Section Sizes			Sections			Width of Boiler	Left Side of Cover to Center of Flue Outlet		Distance Between Flue Centers					Right Side of Cover to Center of Flue Outlet	Base & Battery Length
	300	400	500	L	Inner	R		A	B	C	D	E	F	G		
D247-300	1			1	2	1	18 1/4	9 3/8	Omit	Omit	Omit	Omit	Omit	9 3/8	16 1/4	
D247-400		1		1	3	1	23	11 1/2						11 1/2	21	
D247-500			1	1	4	1	27 1/4	13 5/8						13 5/8	25 1/4	
D247-600	2			1	5	1	31 1/2	9 3/8	12 3/4	↓	↓	↓	↓	9 3/8	29 1/2	
D247-700	1	1		1	6	1	35 3/4	9 3/8	14 7/8	↓	↓	↓	↓	11 1/2	34 3/4	
D247-800		2		1	7	1	40	11 1/2	17	↓	↓	↓	↓	11 1/2	38	
D247-900		1	1	1	8	1	44 1/4	11 1/2	19 1/8	↓	↓	↓	↓	13 3/8	42 1/4	
D247-1000			2	1	9	1	48 1/2	13 3/8	21 1/4	↓	↓	↓	↓	13 3/8	46 1/2	
D247-1100	1	2		1	10	1	52 3/4	9 3/8	14 7/8	17	↓	↓	↓	11 1/2	50 3/4	
D247-1200		3		1	11	1	57	11 1/2	17	17	↓	↓	↓	11 1/2	55	
D247-1300	1		2	1	12	1	61 1/4	9 3/8	17	21 1/4	↓	↓	↓	13 3/8	59 1/4	
D247-1400		1	2	1	13	1	65 1/2	11 1/2	19 1/8	21 1/4	↓	↓	↓	13 3/8	63 1/2	
D247-1500			3	1	14	1	69 3/4	13 3/8	21 1/4	21 1/4	↓	↓	↓	13 3/8	67 3/4	
D247-1600		4		1	15	1	74	11 1/2	17	17	17	↓	↓	11 1/2	72	
D247-1700	1	1	2	1	16	1	78 1/4	9 3/8	14 7/8	19 1/8	21 1/4	↓	↓	13 3/8	76 1/4	
D247-1800		2	2	1	17	1	82 1/2	11 1/2	17	19 1/8	21 1/4	↓	↓	13 3/8	80 1/2	
D247-1900		1	3	1	18	1	86 1/4	11 1/2	19 1/8	21 1/4	21 1/4	↓	↓	13 3/8	84 3/4	
D247-2000			4	1	19	1	91	13 3/8	21 1/4	21 1/4	21 1/4	↓	↓	13 3/8	89	
D247-2100	2		3	1	20	1	95 1/4	9 3/8	12 3/4	17	21 1/4	21 1/4	↓	13 3/8	93 1/4	
D247-2200		3	2	1	21	1	99 1/2	11 1/2	17	17	19 1/8	21 1/4	↓	13 3/8	97 1/2	
D247-2300		2	3	1	22	1	103 3/4	11 1/2	17	19 1/8	21 1/4	21 1/4	↓	13 3/8	101 3/4	
D247-2400		1	4	1	23	1	108	11 1/2	19 1/8	21 1/4	21 1/4	21 1/4	↓	13 3/8	106	
D247-2500			5	1	24	1	112 1/4	13 3/8	21 1/4	21 1/4	21 1/4	21 1/4	↓	13 3/8	110 1/4	
D247-2600	2		4	1	25	1	116 1/2	9 3/8	12 3/4	17	21 1/4	21 1/4	21 1/4	13 3/8	114 1/2	
D247-2700	1	1	4	1	26	1	120 3/4	9 3/8	14 7/8	19 1/8	21 1/4	21 1/4	21 1/4	13 3/8	118 3/4	
D247-2800		2	4	1	27	1	125	11 1/2	17	19 1/8	21 1/4	21 1/4	21 1/4	13 3/8	123	
D247-2900		1	5	1	28	1	129 1/4	11 1/2	19 1/8	21 1/4	21 1/4	21 1/4	21 1/4	13 3/8	127 1/4	
D247-3000			6	1	29	1	133 1/2	13 3/8	21 1/4	21 1/4	21 1/4	21 1/4	21 1/4	13 3/8	131 1/2	

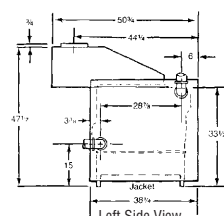
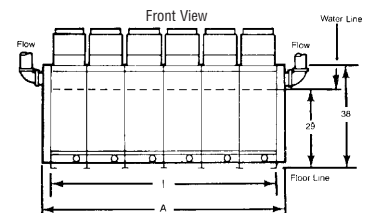
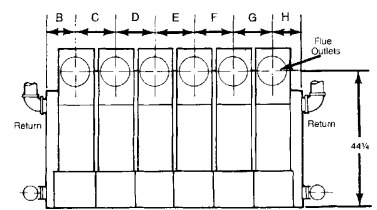

D247 SERIES RIGHT- AND LEFT-END TAPPINGS DATA

OPENING	SIZE	STEAM	WATER
A	4"	Supply	Supply
B	4"	Return	Return
C	1/2"	Low-Water Cutoff and/or Gauge Glass	Plugged
D	1"	Low-Water Cutoff & Feeder Combination	Plugged or Low-Water Cutoff
E	1-1/2"	Drain Left Side	Drain Left Side
E	3/4"	Drain Right Side	Drain Right Side
F	1/2"	Plugged or Pressure Control	Limit Control on Control End of Boiler. Pressure/Temp. Gauge on Opposite End of Boiler
H	3/4"	Probe Low Water Cut-Off	Probe Low Water Cut-Off

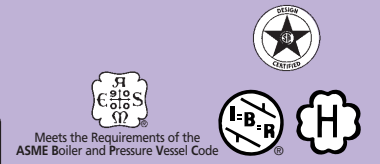
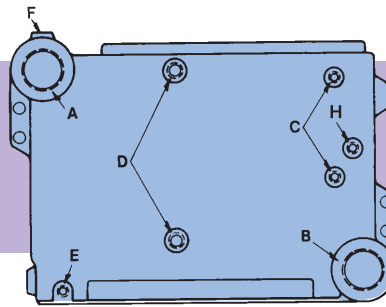

D247 SERIES WATER OR STEAM SPECIFICATIONS

INPUT	OUTPUT	I = B = R RATINGS†			CHIMNEY SIZE #	FLUE OUTLET NO. & SIZE	WATER CAPACITY (Gallons)		OPERATING WGT. LESS PIPING		HORSE-POWER Gross Output**	PRESSURE DROP THRU WATER BOILER††		
		STEAM Sq Ft	STEAM Btu Mbbh	WATER Btu Mbbh			Water Entire Boiler	Steam to Water Line	Steam Lbs.	Water Lbs.		GPM	in. Water	
300	240	750	180	209	8" X 20'	1		26	20	1022	1092	7.16	18.9	0.10
400	320	1000	240	278	10" X 20'		1	33	25	1238	1325	9.55	25.2	0.27
500	400	1250	300	348	12" X 20'		1	40	30	1455	1559	11.94	31.5	0.40
600	480	1500	360	417	12" X 20'	2		46	35	1711	1832	14.33	37.8	0.50
700	560	1750	420	487	12" X 20'	1	1	52	40	1933	2070	16.72	44.1	0.70
800	640	2000	480	557	14" X 20'		2	58	45	2155	2308	19.10	50.4	0.88
900	720	2250	540	626	14" X 20'		1	65	50	2526	2526	21.49	56.7	1.10
1000	800	2500	600	696	14" X 20'		2	71	55	2588	2775	23.88	63.0	1.30
1100	880	2750	660	765	16" X 20'	1	2	78	60	2845	3048	26.27	69.3	1.50
1200	960	3000	720	835	16" X 20'		3	84	65	3085	3305	28.66	75.6	1.80
1300	1040	3250	780	904	16" X 20'	1	2	91	70	3279	3515	31.04	81.9	2.00
1400	1120	3500	840	974	18" X 20'		1	97	75	3545	3815	33.43	88.2	2.40
1500	1200	3750	900	1043	18" X 20'		3	104	80	3813	4063	35.82	94.5	2.60
1600	1280	4008	962	1113	18" X 20'		4	110	85	4010	4312	38.21	100.8	2.80
1700	1360	4283	1028	1183	18" X 20'	1	1	117	90	4234	4554	40.60	107.1	3.15
1800	1440	4563	1095	1252	20" X 20'		2	123	95	4457	4795	42.99	113.4	3.50
1900	1520	4838	1161	1322	20" X 20'		1	130	100	4676	5028	45.37	119.7	4.00
2000	1600	5117	1228	1391	20" X 20'		4	136	105	4895	5261	47.76	126.0	4.40
2100	1680	5392	1294	1461	20" X 20'	2	3	143	110	5138	5523	50.15	132.3	4.85
2200	1760	5671	1361	1530	22" X 20'		3	149	115	5380	5784	52.54	138.6	5.40
2300	1840	5942	1426	1600	22" X 20'		2	156	120	5599	5967	54.93	144.9	5.70
2400	1920	6213	1491	1670	22" X 20'		1	162	125	5815	6149	57.31	151.2	6.00
2500	2000	6471	1553	1739	22" X 20'		5	169	130	6068	6507	59.70	157.5	6.50
2600	2080	6729	1615	1809	22" X 20'	2	4	175	135	6321	6865	62.09	163.8	7.00
2700	2160	6988	1677	1878	24" X 20'	1	1	182	140	6551	7075	64.48	170.1	7.50
2800	2240	7246	1739	1948	24" X 20'		2	188	145	6780	7285	66.87	176.4	8.00
2900	2320	7504	1801	2017	24" X 20'		1	195	150	7007	7511	69.25	182.7	8.50
3000	2400	7763	1863	2087	24" X 20'		6	201	155	7234	7737	71.64	189.1	9.00

* RATINGS ARE AT SEA LEVEL TO 2,000 FEET. FOR ALTITUDES ABOVE 2,000 FEET, REDUCE ALL RATINGS 4% FOR EACH 1,000 FEET ABOVE SEA LEVEL.
 † RATINGS BASED ON SELECTION FACTORS RECOMMENDED BY HYDRONICS INSTITUTE FOR PIPING AND PICKUP. NET WATER BOILER RATINGS ARE BASED ON AN ALLOWANCE OF 1.15, AND NET STEAM BOILER RATINGS ARE BASED ON AN ALLOWANCE OF 1.33. FOR WATER APPLICATIONS WITH HIGH PIPING AND PICKUP REQUIREMENTS, USE STEAM RATING.
 ‡ RATINGS IN SQUARE FEET ARE COMPUTED AT 240 Btu/h/ SQUARE FOOT FOR STEAM BOILERS.
 ** RATINGS BASED ON 33,500 BTUH PER HORSEPOWER.
 †† PRESSURE DROP BASED ON GIVEN FLOW FROM A SINGLE OUTLET AND RETURNING TO A SINGLE INLET AT THE OPPOSITE END OF THE BOILER.
 # CHIMNEY SIZES SHOWN ARE ONE OPTION BASED ON A TYPICAL VENTING SYSTEM, AND SIZED ACCORDING TO THE NATIONAL FUEL GAS CODE, ASSUMING TYPE B DOUBLE WALL VENT AND VENT CONNECTORS. OTHER VENTING SYSTEM DESIGNS ARE ACCEPTABLE. FOR FURTHER CHIMNEY DESIGN AND SIZING INFORMATION, CONSULT THE NATIONAL FUEL GAS CODE, ANSI Z223.1/NFPA 54-LATEST REVISION; OR ASHRAE-1996 HVAC SYSTEMS AND EQUIPMENT HANDBOOK, CHAPTER 30, CHIMNEY, GAS, VENT, AND FIREPLACE SYSTEMS; OR THE STANDARD FOR CHIMNEYS, FIREPLACES, VENTS, AND SOLID FUEL BURNING APPLIANCE NFPA 211-LATEST REVISION. FOLLOW STANDARD ENGINEERING PRACTICE.

- The ratings marked Net I=B=R Ratings represent the heat available to the radiation or terminal units.
- Water boiler size should be based upon Net I=B=R Rating being equal to or greater than the calculated heat loss of the building.
- Selection of steam boiler size should be based upon Net I=B=R Steam Rating being equal to or greater than the installed radiation in square feet EDR.
- Consult manufacturer before selecting a boiler for installations having unusual piping and pick-up requirements.

- These gas-fired boilers are sectional cast iron boilers design certified by CSA in the U.S. for use with natural gas. They are constructed and hydrostatically tested for a maximum working pressure of 100 psi in accordance with A.S.M.E. (American Society of Mechanical Engineers) Boiler And Pressure Vessel Code Section IV standards for cast iron heating boilers. They are capacity rated in accordance with the code of The Hydronics Institute.



85 MIDDLE RD DUNKIRK, NY 14048
716/366-5500 FAX 716/366-1209
 e-mail: heating@dunkirk.com
 Web Site: www.dunkirk.com

An **ECR** International Brand

An ISO 9001-2000 Certified Company

Specifications and dimensions are subject to change without notice.
 Made in America by American Craftsmen.
 D247 • 11/03 Rev

