

# Igniter Replacement Kit Instructions

## Q/UB 90-100 Series II & III

Kit # 550002797

### Purpose

- Release of enhanced igniter kit for 90-100 Series II & III.
- Intended use is only 90-100 family series II and series III boilers Natural Gas and Propane (50 MBH, 75 MBH and 100 MBH) which utilize direct spark ignition.
- Replacement igniter kits are offered any boiler within serial number range: first four digits between 3312 and 0313. These boilers were manufactured between August 20th, 2012 and January 30th 2013.

Kit installation shall be completed by qualified agency.

### WARNING

Fire, explosion, asphyxiation and electrical shock hazard. Improper installation could result in death or serious injury. Read these instructions and understand all requirements, including requirements of authority having jurisdiction, before beginning installation. Installation not complete until appliance operation is verified per Installation, Operation & Maintenance Manual provided with boiler.

### Igniter Removal

1. Tools required:
  - Flat Screw driver or 5/16 inch nut driver
  - Manometer to check/adjust gas pressure
  - 1/8" NPT Barb
  - 3/16" Allen Wrench
  - Torx T-40 Wrench or flat screw driver
  - Wire Cutters
2. Follow instructions to TURN OFF GAS TO APPLIANCE found on Operating Instructions label on boiler or in Installation, Operation & Maintenance Manual. Verify all electrical power to boiler is turned off.



### WARNING

Electrical shock hazard. Turn OFF electrical power supply at service panel.

### WARNING

Burn hazard. Verify heat exchanger and igniter have cooled or use appropriate personal protection equipment before removing igniter.

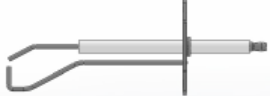
### Parts List

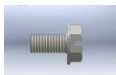
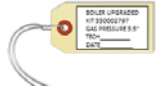
Parts	Quantity	Picture
New igniter	1	
Graphite Gasket	1	
Ground Terminal	1	
10-32 x 3/8" Screws	2	
Hang tag	1	
Instructions	1	240010031
Labor Reply Card	1	240010035
Transformer Harness	1	
Zip-Ties	2	

## IGNITER REPLACEMENT KIT INSTRUCTIONS

3. Inspect combustion chamber through sight glass. Verify flame is not present.
4. Disconnect ignition cable and ground wire from igniter.
5. Remove two igniter screws (top and bottom).
6. Remove igniter and silicone gasket under igniter flange.
7. Remove old igniter gasket.

### Igniter Installation

1. Install new igniter and graphite gasket. New igniter fits only one way.
2. Separate green quick connect ground wire from wire harness.
3. Install ground terminal under lower igniter screw with tab facing left.
4. Tighten both screws. Verify igniter is securely in place.
5. Connect ignition cable and green grounding wire to igniter.
6. Close gas valve, set boiler for call for heat, inspect blower housing and vent pipe connection for secure connections and possible flue gas leaks around igniter.
7. Replace transformer harness. Follow Harness Replacement Procedure found on Page 3.
8. Resume operation using OPERATING INSTRUCTION found on Operating Instructions label on boiler or in Installation, Operation & Maintenance Manual.
9. Adjust gas manifold pressure to 3.0 - 3.2 inch water. Follow Gas Pressure Adjustment found on Page 3.

### **WARNING**

Fire, explosion, asphyxiation hazard. Venting **not** installed to specifications as required in boiler's Installation, Operation and Maintenance Manual or for installations above 2000 ft. shall be required to use a combustion analyzer to verify CO and CO<sub>2</sub>. Failure to follow these instructions and venting requirements as listed in Installation, Operation and Maintenance Manual could result in death or serious injury.

### Typical Boiler Operation Should Be Between

8.5% -10.0% CO<sub>2</sub> on Natural Gas

9.5% -11.0% CO<sub>2</sub> on Propane Gas

Under all conditions CO level should not exceed 100ppm.

10. Fire boiler several times after gas adjustment to verify ignition quality.
11. Sign and date notice tag. Hang on gas valve.

Figure 1 - Remove Ignitor (Procedure 2 To 4)

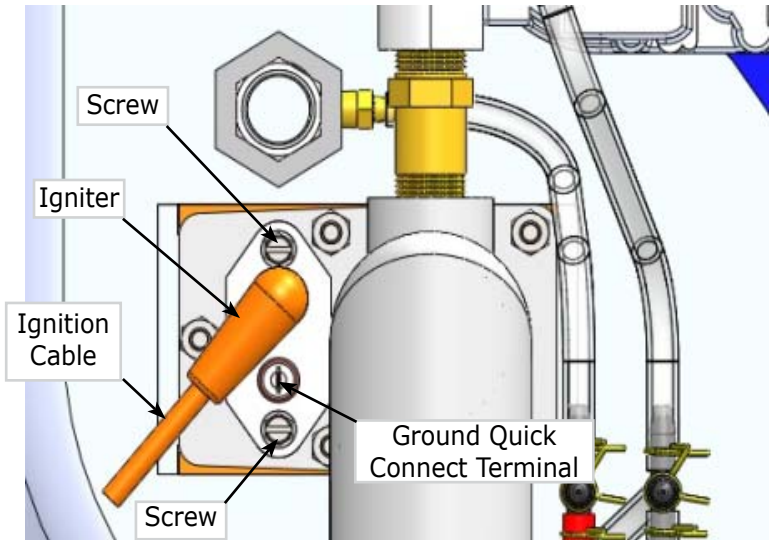
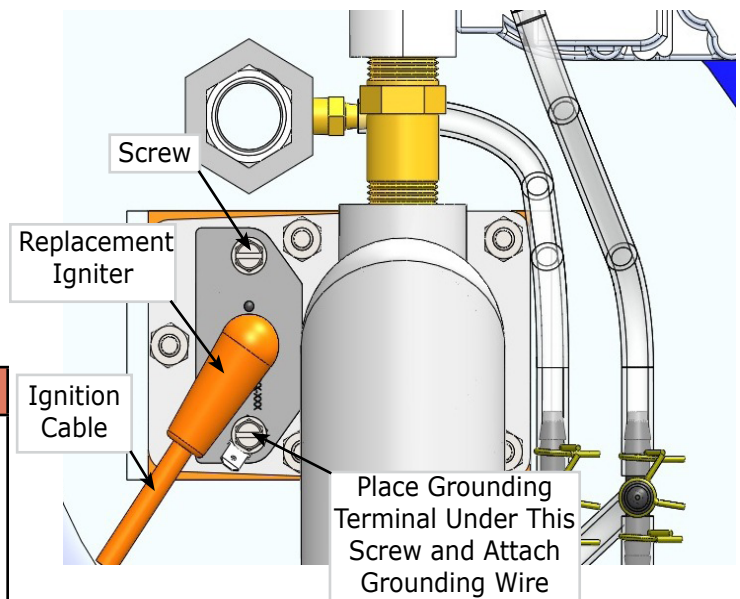

Figure 2 - Replace Ignitor (Procedure 5 To 9)



# IGNITER REPLACEMENT KIT INSTRUCTIONS

## Gas Pressure Adjustment

1. Follow instructions to Turn Off Gas to Appliance found on Operating Instructions label on boiler or in Installation, Operation & Maintenance Manual. Verify all electrical power to boiler is turned off.
2. Open outlet pressure tap and pressure regulator adjustment ports on gas valve by removing their cover screws.
3. Thread 1/8" NPT barb into outlet pressure port. Attach manometer.
4. Use screw (T-40 or flat screw driver) located at pressure regulator to adjust manifold pressure.
5. After final adjustment shut boiler off. Remove instrumentation and install port covers.

Figure 3 - Gas Valve

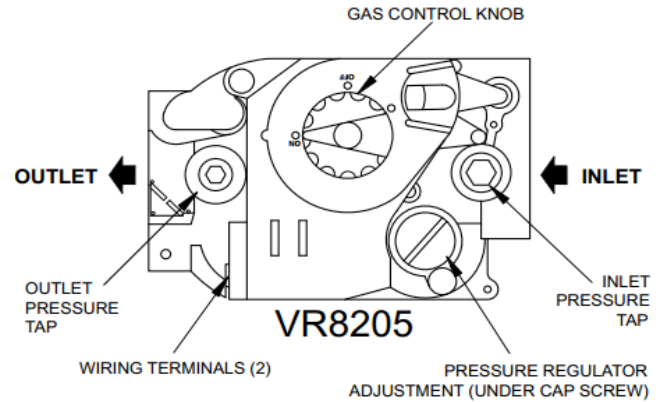

## Harness Replacement Procedure

### **⚠ WARNING**

Electrical shock hazard. Turn OFF electrical power supply at service panel.

1. Locate boiler 24 VAC transformer. Disconnect yellow wires connected to load side
2. Disconnect molex connector attached to control board identified as secondary.
3. Cut two zip-ties to free yellow wire harness.
4. Replace with new harness and attach connections.
5. Attach supplied zip-ties to secure wires.

Figure 4 - 24V Transformer Wire Harness

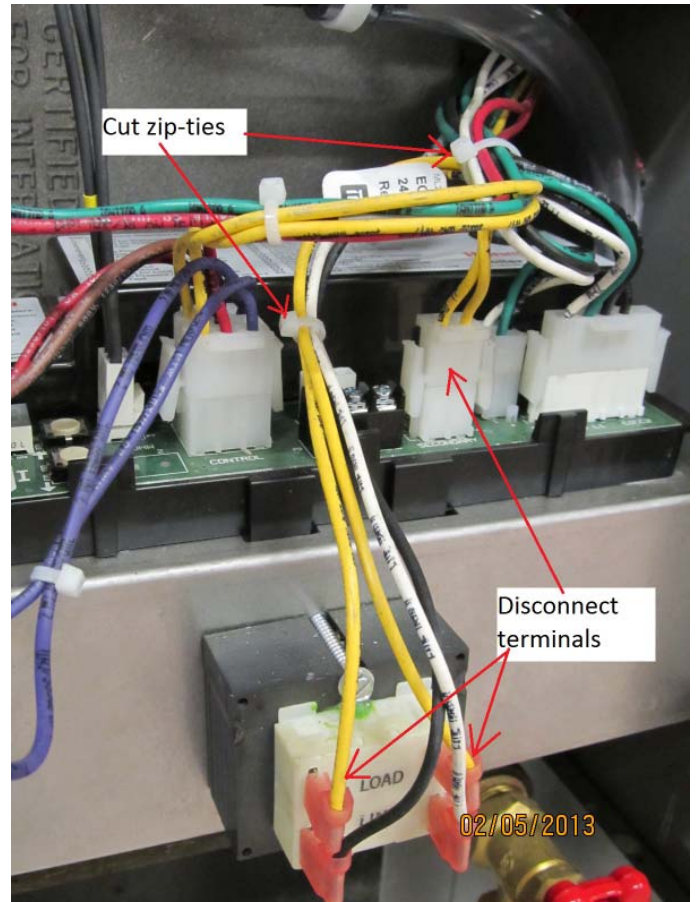

Technical Support - 1-800-325-5479

ECR International  
2201 Dwyer Ave.  
Utica, NY 13502