



Models
DXL-50
DXL-75
DXL-100
DXL-125
DXL-150
DXL-170
DXL-200

DXL SERIES II

CAST IRON GAS FIRED BOILERS
FOR FORCED HOT WATER

INSTALLATION, OPERATION & MAINTENANCE MANUAL

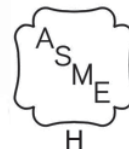

Tested For 100 psi.
ASME
Working Pressure



An ISO 9001-2008 Certified Company

Manufactured by:
ECR International, Inc.
2201 Dwyer Avenue, Utica NY 13501
web site: www.ecrinternational.com

P/N 2400009041, Rev. A [04/2012]

1- DIMENSIONS

Figure 1 - Dimensions

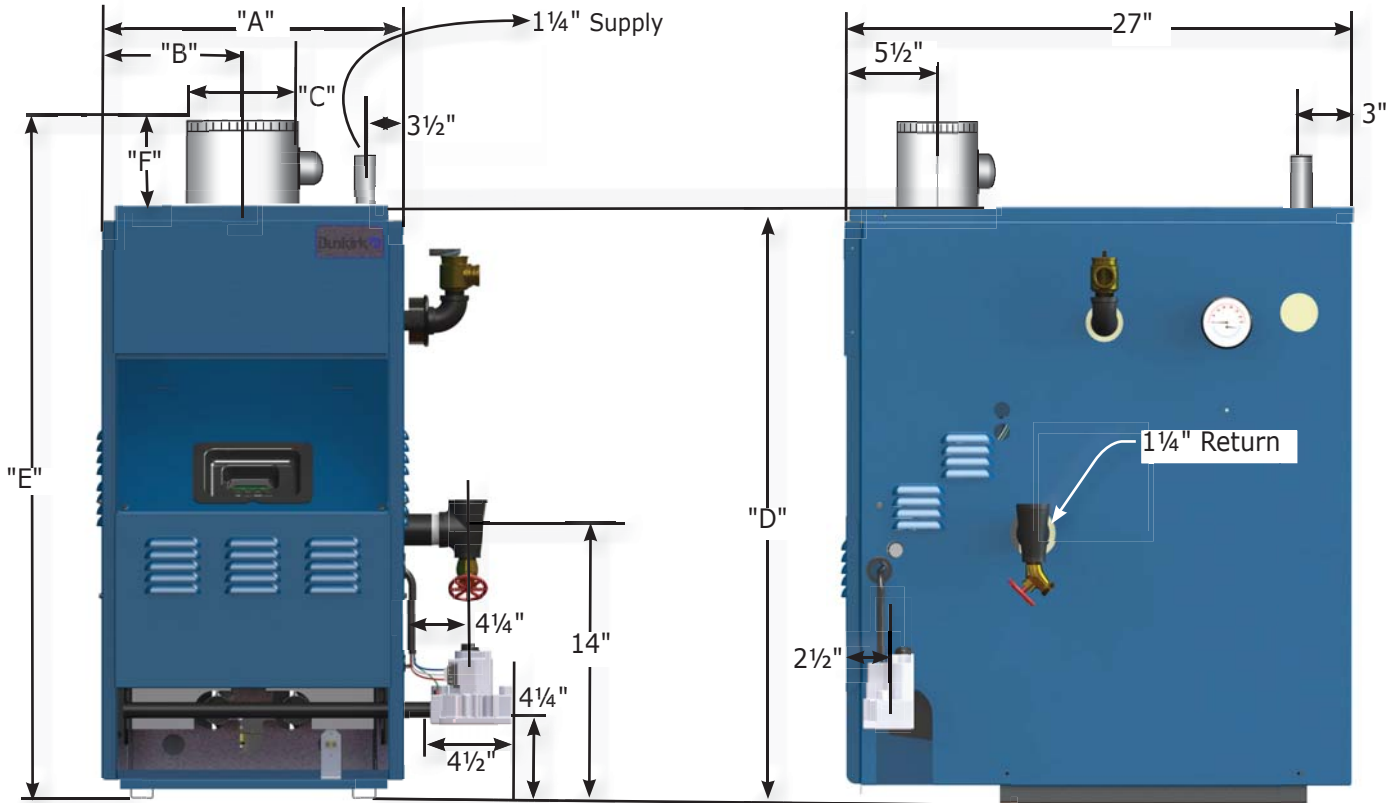

Table 1 - Dimensions

Boiler No.	Natural Gas Inlet*	Dimensions						Pump size Supply & Return Tappings
		A	B	C	D	E	F	
50	1/2"	11 1/8"	5 1/2"	4"	30 3/4"	36 3/4"	6"	1 1/4"
75	1/2"	15	7 1/2"	5"	30 3/4"	36 3/4"	6"	1 1/4"
100	1/2"	15	7 1/2"	6"	30 3/4"	37 1/4"	6 1/2"	1 1/4"
125	1/2"	18 7/8"	9 1/2"	6"	30 3/4"	37 1/4"	6 1/2"	1 1/4"
150	1/2"	18 7/8"	9 1/2"	7"	30 3/4"	37 3/4"	7"	1 1/4"
170	1/2"	22 3/4"	11 1/2"	7"	30 3/4"	38 3/4"	7"	1 1/4"
200	1/2"	22 3/4"	11 1/2"	8"	30 3/4"	38 3/4"	8"	1 1/4"

2 - SAFETY SYMBOLS & WARNINGS

1 - Dimensions.....	2
2 - Safety Symbols & Warnings	3
3 - Ratings & Data - Natural Gas & Propane Gas	4
4 - Installation Procedure	5
5 - Ventilation & Combustion Air	6
6 - Supply And Return Piping	7
7 - Vent Installation	12
8 - Vent System Modification.....	12
9 - Vent Damper Installation & Instructions.....	13
10 - Connecting Gas Service	14
11 - Electrical Section	15
12 - Wiring Diagram - Intermittent Ignition.....	16
13 - Lighting Instructions	18
14 - Sequence Of Operation.....	19
15 - General Instructions.....	19
16 - Checking Gas Input Rate To Boiler.....	21
17 - Setting The Control.....	22
17 - System Start-Up.....	23
17 - Limit Control Troubleshooting	24
18 - System Troubleshooting.....	25

Safety Symbols & Warnings

The following defined symbols are used throughout this manual to notify the reader of potential hazards of varying risk levels.

DANGER

Indicates a hazardous situation which, if not avoided, WILL result in death or serious injury

WARNING

Indicates a hazardous situation which, if not avoided, could result in death or serious injury.

CAUTION

Indicates a hazardous situation which, if not avoided, could result in minor or moderate injury.

NOTICE

Used to address practices not related to personal injury.

**KEEP THIS MANUAL NEAR BOILER
RETAIN FOR FUTURE REFERENCE**

**IMPORTANT: Read the following instructions
COMPLETELY before installing!!**

WARNING

Fire, explosion, asphyxiation and electrical shock hazard. Improper installation could result in death or serious injury. Read this manual and understand all requirements before beginning installation.

WARNING

Keep boiler area clear and free from combustible materials, gasoline and other flammable vapors and liquids.
DO NOT obstruct air openings to the boiler room. Modification, substitution or elimination of factory equipped, supplied or specified components may result in personal injury or loss of life.
TO THE OWNER - Installation and service of this boiler must be performed by a qualified installer.
TO THE INSTALLER - Leave all instructions with boiler for future reference.
When this product is installed in the Commonwealth of Massachusetts the installation must be performed by a Licensed Plumber or Licensed Gas Fitter.



Table 2 - Ratings and Capacities

Boiler No.	(1) Input Mbh	(1) Heating Capacity Mbh	(2) Net AHRI Rating Water Mbh	AFUE	No. of Burners	(3) Recommended Air Cushion Tank	Water Content (Gals.)	High Altitude Input
50	50	42	37	83.5	1	15	2.4	45,000
75	75	63	55	83.1	2	15	4.0	67,500
100	100	83	72	83.0	2	30	4.0	90,000
125	125	104	90	82.0	3	30	5.6	112,500
150	150	124	108	83.0	3	30	5.6	135,000
170	170	139	121	82.0	4	30	7.2	153,000
200	200	165	143	82.0	4	30	7.2	180,000

EXPLANATORY NOTES

- All boilers are design certified for installation on noncombustible floor.
- For installation on combustible floors use combustible floor kit.
- Recommended chimney height 20 feet. In special cases where conditions permit, chimney height may be reduced to 10 feet. Refer to the latest revision of NFGC part 11.
- Electric service to be 120 Volts, 15 Amps, 60 Hz.
- The MEA number for the this boiler is 19-79-E.

(1) Input rating for sea level to 2,000 ft. (610m) above sea level. United States, over 2000 ft (610m) above sea level. Reduce input rate 4% for every 1000 ft (304m) above sea level.

(2) Net AHRI Water Ratings shown based on piping and pickup allowance of 1.15. Consult manufacturer before selecting boiler for installations having unusual piping and pickup requirements, such as intermittent system operation, extensive piping systems, etc.

For forced hot water systems where boiler and all piping within area to be heated, boiler may be selected on basis of its heating capacity.

(3) Tank sized for non-ferrous baseboard or radiant panel systems. Increase size for cast iron baseboard and radiation.

STANDARD EQUIPMENT: Boiler Jacket, Cast Iron Boiler Battery, Combination High Limit/Low Water Cutoff Control, Intermittent Electric Ignition Pilot System, Vent Damper Relay, Temperature/Pressure Gauge, Circulator With Return Piping To Boiler, Main Gas Burners, Gas Control (Includes Automatic Gas Valve, Gas Pressure Regulator, Intermittent Pilot, Safety Shutoff, Pilot Flow Adjustment, Pilot Filter), A.S.M.E. Relief Valve, Drain Valve, Spill Switch, Rollout Switch, Combination Gas Control, Automatic Vent Damper. Not Shown Are: Wiring Harness, Thermocouple, Non-linting Safety Pilot.

4 - INSTALLATION PROCEDURE

⚠ WARNING

Improper installation, adjustment, alteration, service or maintenance could result in death or serious injury.

1. Installation must conform to requirements of authority having jurisdiction or, in absence of such requirements, to the National Fuel Gas Code, ANSI Z223.1/NFPA 54.
2. Where required by authority having jurisdiction, installation must conform to the Standard for Controls and Safety Devices for Automatically fired Boilers, ANSI/ASME CSD-1.
3. Boiler series is classified as Category I. Vent installation shall be in accordance with "Venting of Equipment," of the National Fuel Gas Code, ANSI Z223.1/NFPA 54, or applicable provisions of local building codes.
4. Boiler has met safe lighting and other performance criteria with gas manifold and control assembly on boiler per latest revision of ANSI Z21.13/CGA 4.9.
5. Boiler shall be installed such that gas ignition system components are protected from water (dripping, spraying, rain, etc.) during appliance operation and service, (circulator replacement, condensate trap, control replacement, etc.).
6. Locate boiler on level, solid base as near chimney as possible and centrally located with respect to heat distribution system as practical.
7. Allow 24 inches (610mm) at front and right side for servicing and cleaning.
8. When installed in utility room, door should be wide enough to allow largest boiler part to enter, or to permit replacement of another appliance such as water heater.

⚠ WARNING

Fire hazard. Do not install boiler on combustible flooring or carpeting. Failure to follow these instructions could result in death or serious injury.

9. **FOR INSTALLATION ON NON-COMBUSTIBLE FLOORS ONLY** - For installation on combustible flooring special base must be used. (See Replacement Parts Section.) **Boiler can not be installed on carpeting.** Minimum clearances to combustible construction are:

TOP	18 IN. (457mm)
FRONT	ALCOVE *
FLUE CONNECTOR	6 IN. (152mm)
REAR	4 IN. (102mm)
CONTROL SIDE	9 IN. (229mm)
OTHER SIDE	3 IN. (76mm)
HOT WATER PIPING	2IN. (51mm)

NOTE: Greater clearances for access should supersede fire protection clearances.

* Definition of Alcove is three sided space with no wall in front of boiler. ANSI standard for alcove is 18 inches from front of appliance to leading edge of side walls as shown below.

Figure 2 - Clearance to Combustibles

Minimum Clearances to Combustible Construction (as seen from above)

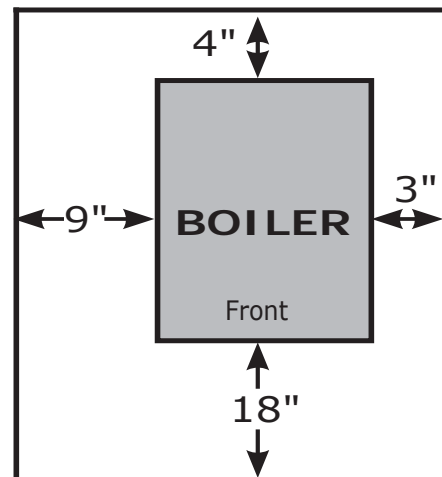

5 - VENTILATION & COMBUSTION AIR

Provide combustion air and ventilation air in accordance with the section "Air for Combustion and Ventilation," of the National Fuel Gas Code, ANSI Z223.1/NFPA 54, or applicable provisions of local building codes.

Provide make-up air where exhaust fans, clothes dryers, and kitchen ventilation equipment interfere with proper operation.

National Fuel Gas Code recognizes several methods of obtaining adequate ventilation and combustion air. Requirements of the authority having jurisdiction may override these methods.

- Engineered Installations. Must be approved by authority having jurisdictions.
- Mechanical Air Supply. Provide minimum of 0.35 cfm per Mbh for all appliances located within space. Additional requirements where exhaust fans installed. Interlock each appliance to mechanical air supply system to prevent main burner operation when mechanical air supply system not operating.
- All Indoor Air. Calculate minimum volume for all appliances in space. Use a different method if minimum volume not available.
 - Standard Method. Cannot be used if known air infiltration rate is less than 0.40 air changes per hour. See Table 3 for space with boiler only. Use equation for multiple appliances.

$$\text{Volume} \geq 50 \text{ ft}^3 \times \text{Total Input [Mbh]}$$
 - Known Air Infiltration Rate. See Table 3 for space with boiler only. Use equation for multiple appliances. Do not use an air infiltration rate (ACH) greater than 0.60.

$$\text{Volume} \geq 21 \text{ ft}^3/\text{ACH} \times \text{Total Input [Mbh]}$$
 - Refer to National Fuel Gas Code for opening requirements between connection indoor spaces.

- All Outdoor Air. Provide permanent opening(s) communicating directly or by ducts with outdoors.
 - Two Permanent Opening Method. Provide opening commencing within 12 inches of top and second opening commencing within 12 inches of bottom enclosure.
 - Direct communication with outdoors or communicating through vertical ducts. Provide minimum free area of 1 in² per 4 Mbh of total input rating of all appliances in enclosure.
 - Communicating through horizontal ducts. Provide minimum free area of 1 in² per 2 Mbh of total input rating of all appliances in enclosure.
 - One Permanent Opening Method. Provide opening commencing within 12 inches of top of enclosure. Provide minimum clearance of 1 inch on sides and back and 6 inches on front of boiler (does not supersede clearance to combustible materials).
 - Combination Indoor and Outdoor Air. Refer to National Fuel Gas Code for additional requirements for louvers, grilles, screens and air ducts.
- Combination Indoor and Outdoor Air. Refer to National Fuel Gas Code for application information.

National Gas and Propane Installation Code Requires providing air supply in accordance with:

- Section 8.2 and 8.3 when combination of appliances has a total input of up to and including 400 Mbh (120 kW).
- Section 8.4 when combination of appliances has total input exceeding 400 Mbh (120 kW).
- Refer to Natural Gas and Propane Installation Code for specific air supply requirements for enclosure or structure where boiler is installed, including air supply openings and ducts.

Table 3 - Ventilation & Combustion Air

Input Mbh	Standard Method	Known Air Infiltration Rate Method ACH (Air Changes Per Hour)					
		0.1	0.2	0.3	0.4	0.5	0.6
50	2500	10500	5250	3500	2625	2100	1750
75	3750	15750	7875	5250	3938	3150	2625
100	5000	21000	10500	7000	5250	4200	3500
125	6250	26250	13125	8750	6563	5250	4375
150	7500	31500	15750	10500	7875	6300	5250
170	8500	35700	17850	11900	8925	7140	5950
200	10000	42000	21000	14000	10500	8400	7000

**WARNING**

Burn or Scald Hazard. Discharge line shall be installed to relief valve outlet connection to avoid burns, scalding, or water damage due to discharge of steam and/or hot water during operation.

Discharge line shall:

- Connect to relief valve outlet and piped down to safe point of disposal. Check local codes for maximum distance from floor or allowable safe point of discharge.
- Be of pipe size equal to or greater than that of the relief valve outlet over the entire length of discharge line.
- Have no intervening shutoff valve between safety relief valve and discharge to atmosphere (do not plug or place any obstruction in discharge line).
- Terminate freely to atmosphere where any discharge will be clearly visible and at no risk of freezing.
- Allow complete drainage of the valve and the discharge line.
- Be independently supported and securely anchored to avoid applied stress on the relief valve.
- Be as short and straight as possible.
- Terminate with plain end (not threaded).
- Be constructed of material suitable for exposure to temperatures of 375°F (191°C); or greater.

Refer to local codes and appropriate ASME Boiler and Pressure Vessel Code for additional installation requirements.

Figure 3 - Safety Relief Valve

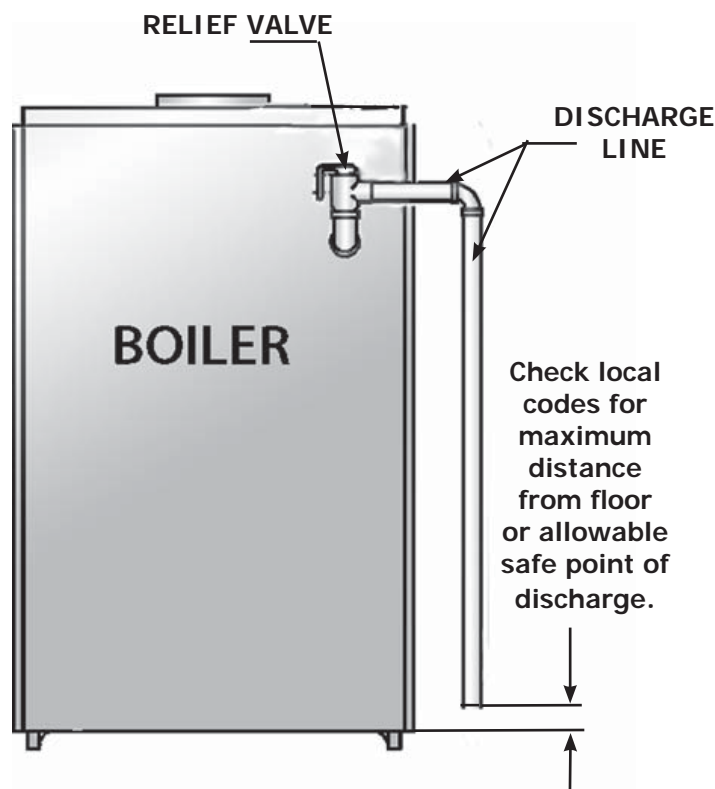

6 - SUPPLY AND RETURN PIPING

IMPORTANT: Circulators in the following illustrations are mounted on the system supply side, but mounting on the system return side is also acceptable practice.

**Figure 4 - Circulators Mounted on Supply System, Boiler Used In Configuration to Chiller System.
See Special Conditions, Page 9**

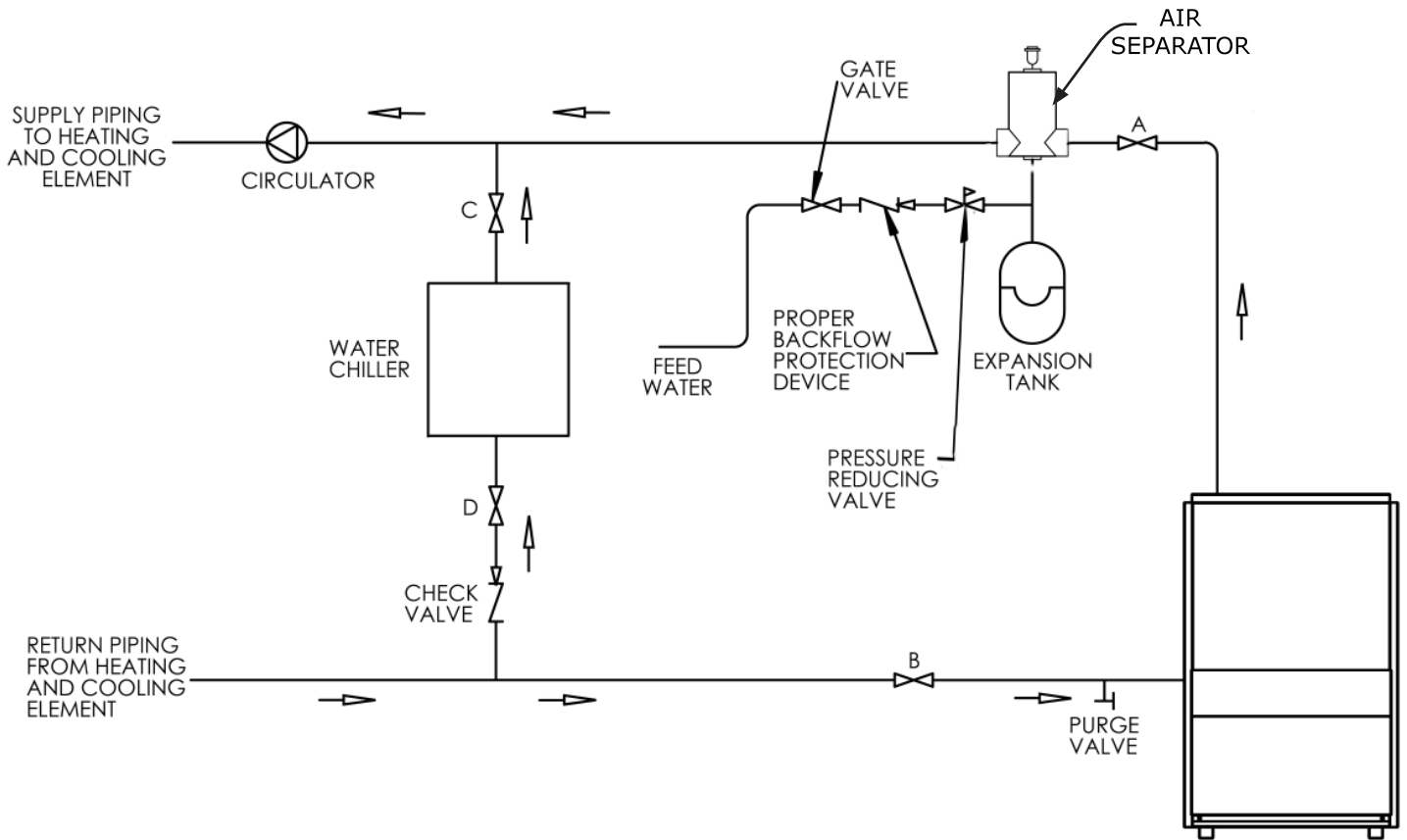

1. Boiler, used in connection with a refrigeration system, must be installed so chilled medium is piped in parallel with boiler with appropriate valves to prevent chilled medium from entering boiler. See Figure 4.
2. Boiler piping system of hot water boiler connected to heating coils located in air handling units where they may be exposed to refrigerated air circulation must be equipped with flow control valves or other automatic means to prevent gravity circulation of boiler water during cooling cycle.
3. Hot water boilers installed above radiation level or as required by authority having jurisdiction must be provided with a low water cut-off device.
4. When a boiler is connected to a heating system that utilizes multiple zoned circulators, each circulator must be supplied with a flow control valve to prevent gravity circulation.
5. Hot water boilers and system must be filled with water and maintained to a minimum pressure of 12 psi.
6. Bypass piping is an option which gives the ability to adjust the supply boiler water temperature to fit the system or the condition of the installation. This method of piping, however, is not typically required for base-board heating systems. Typical installations where bypass piping is used are as follows:
 - A. This method is used to protect boilers from condensation forming due to low temperature return water. Generally noticed in large converted gravity systems or other large water volume systems. Figure 5 & 6, Page 9.
 - B. These methods are used to protect systems using radiant panels and the material they are encased in from high temperature supply water from the boiler and protect the boiler from condensation.

NOTE#1: When using bypass piping, adjust valves V1 & V2 until desired system temperature is obtained.

NOTE#2: Bypass loop must be same size piping as the supply and return piping.

Figure 5 - Bypass Piping Automatic Mixing Valve

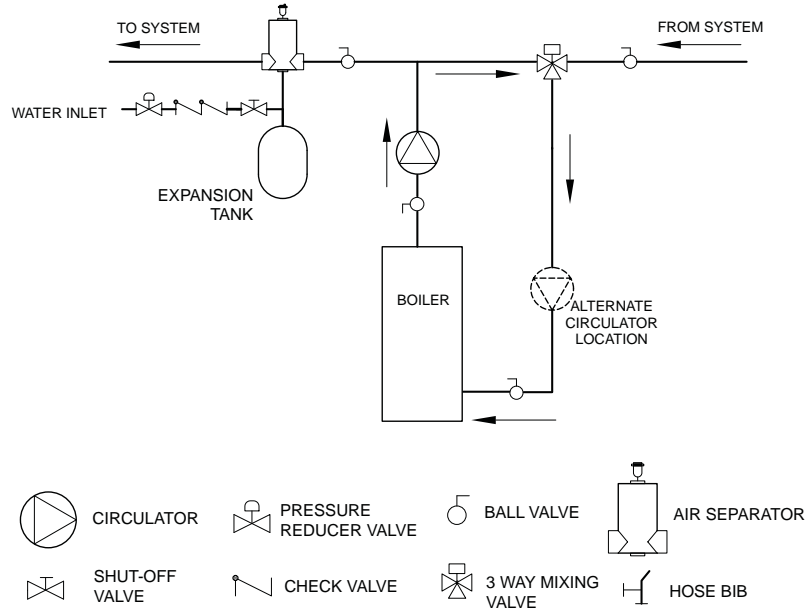
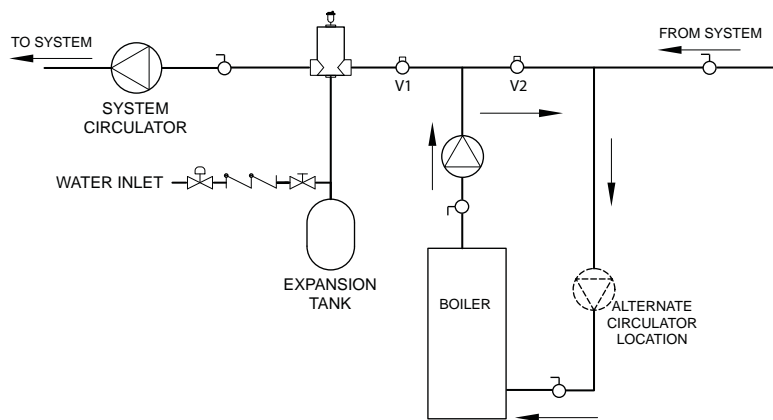

Figure 6 - Bypass Piping - Fixed Low Temp Only Manual Mixing Valve



7. Installation using circulators and zone valves are shown in Figure 7, 8, 9 and 10 Pages 10, and 11. For further piping information refer to AHRI Installation and Piping Guide.

⚠ WARNING

Burn and scald hazard. Safety relief valve could discharge steam or hot water during operation. Install discharge piping per these instructions.

8. Install discharge piping from safety relief valve. See Warning, Page 7.

Figure 7 - Single Zone System With DHW Priority

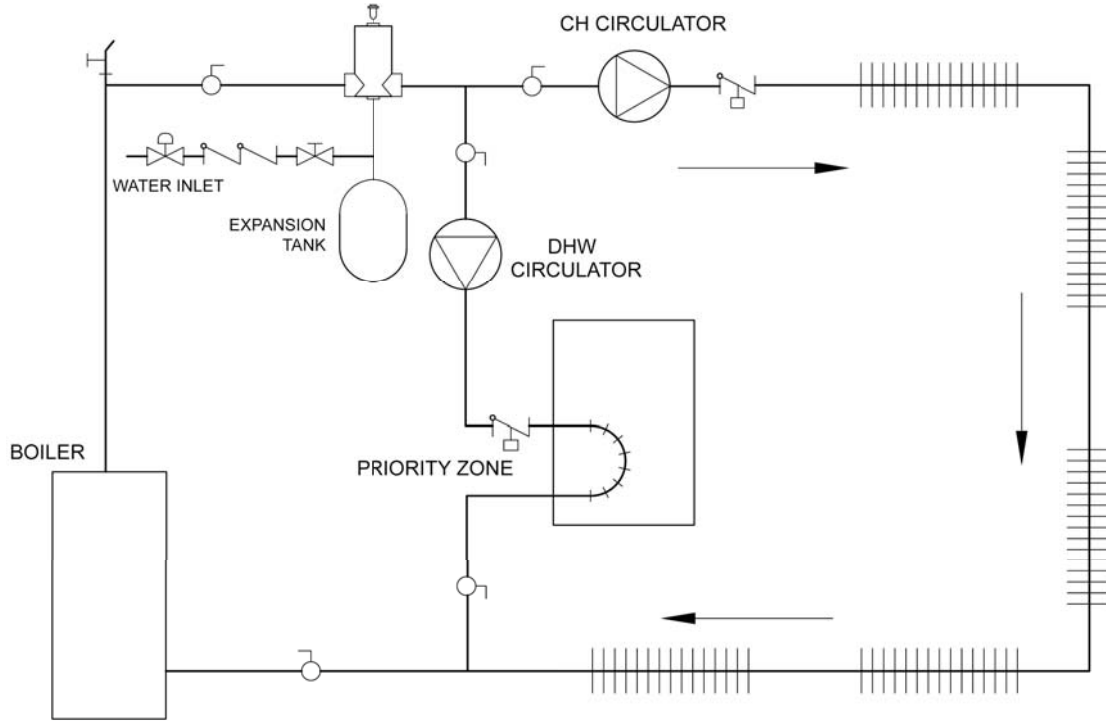

Figure 8 - Multi Zone System With Circulators And DHW Priority

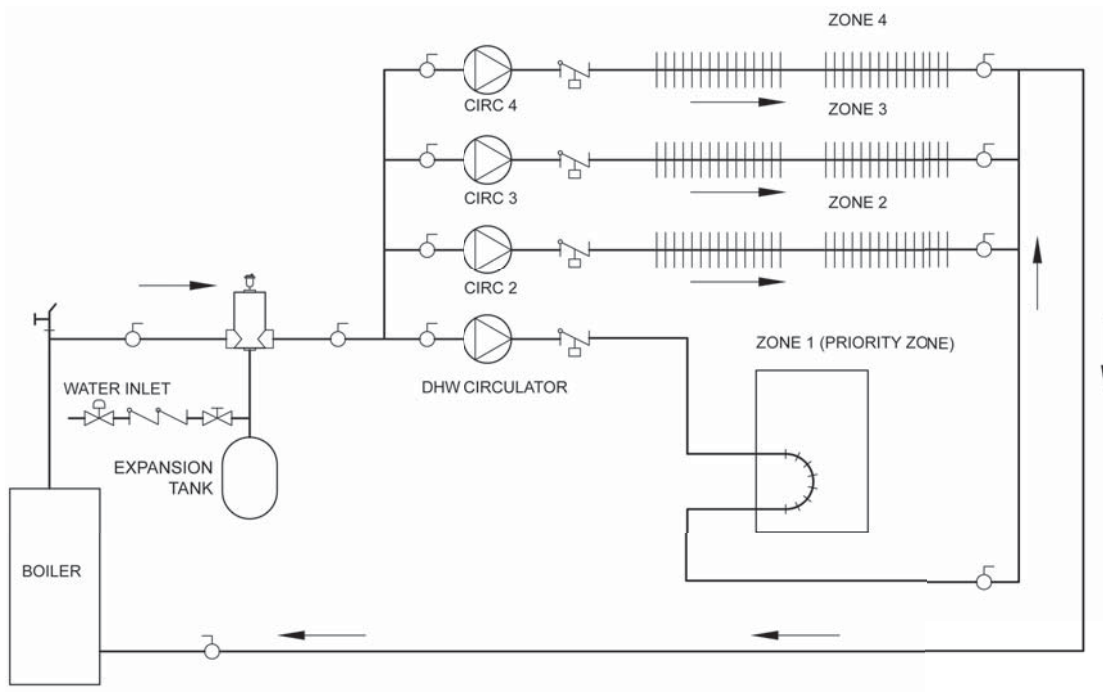

Figure 9 - Multi Zone System With Zone Valves And DHW Priority (With Circulator)

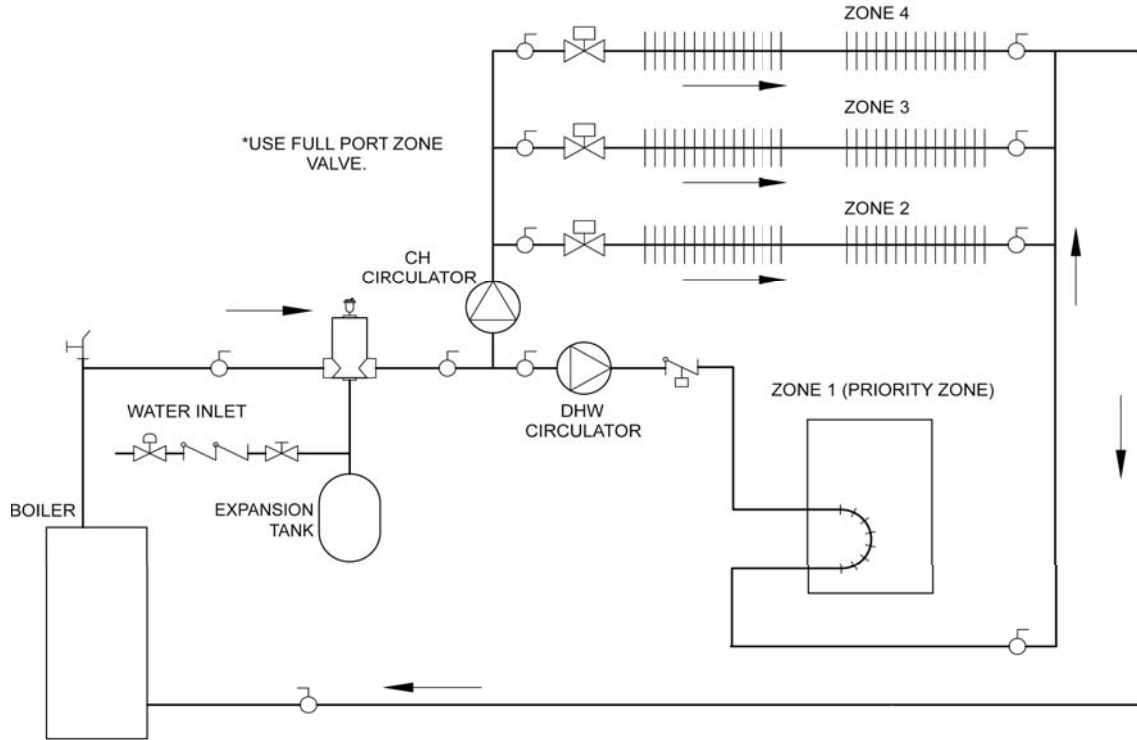
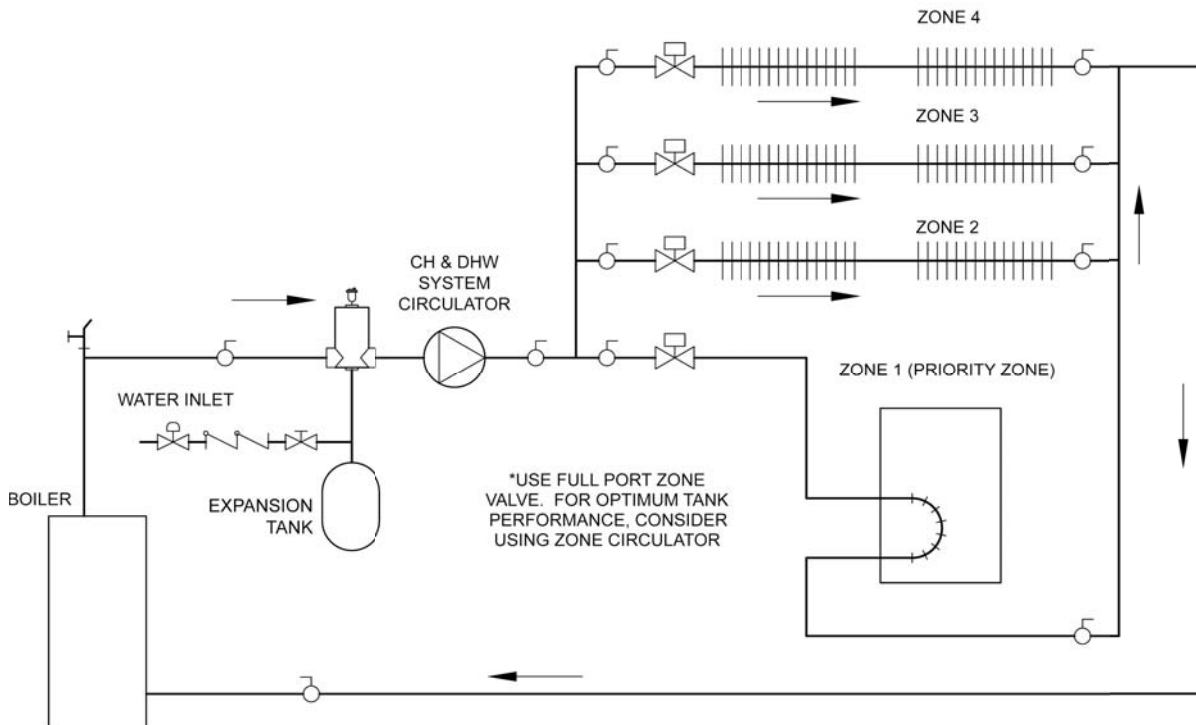

Figure 10 - Multi Zone System With Zone Valves And DHW Priority (With Zone Valve)



7 - VENT INSTALLATION

WARNING

Boiler and venting installations shall be performed by a qualified expert and in accordance with the appropriate manual. Installing or venting boiler or other gas appliance with improper methods or materials may result in serious injury or death due to fire or to asphyxiation from poisonous gases such as carbon monoxide which is odorless and invisible.

WARNING

Do not connect boiler to any portion of mechanical draft system operating under positive pressure.

1. The vent pipe must slope upward from the boiler not less than ¼ inch for every 1 foot (21mm/m) to vent terminal.
2. Horizontal portions of the venting system shall be supported rigidly every 5 feet and at the elbows. No portion of the vent pipe should have any dips or sags.
3. This boiler series is classified as a Category I. Vent installation shall be in accordance with "Venting of Equipment," of the National Fuel Gas Code, ANSI Z223.1/NFPA 54, or applicable provisions of the local building codes.
4. Inspect chimney to make certain it is constructed according to NFPA 211. The vent or vent connector shall be Type B or metal pipe having resistance to heat and corrosion not less than that of galvanized sheet steel or aluminum not less than 0.016 inch thick (No. 28 Ga).
5. Connect flue pipe from draft hood to chimney. Bolt or screw joints together to avoid sags. Flue pipe should not extend beyond inside wall of chimney. Do not install manual damper in flue pipe or reduce size of flue outlet except as provided by the latest revision of ANSI Z223.13.. Protect combustible ceiling and walls near flue pipe with fireproof insulation. Where two or more appliances vent into a common flue, the area of the common flue must be at least equal to the area of the largest flue plus 50 percent of the area of each additional flue.

8 - VENT SYSTEM MODIFICATION

When an existing boiler is removed from a common venting system, the system is likely to be too large for the proper venting of the appliances still connected to it. If this situation occurs, the following test procedure must be followed:

REMOVAL OF BOILER FROM VENTING SYSTEM

At the time of removal of an existing boiler, the following steps shall be followed with each appliance remaining connected to the common venting system placed in operation, while the other appliances remaining connected to the common venting system are not in operation.

1. Seal an unused opening in the common venting system.
2. Visually inspect the venting system for proper size and horizontal pitch and determine there is no blockage or restriction, leakage, corrosion and other deficiencies which could cause an unsafe condition.
3. Insofar as is practical, close all building doors and windows and all doors between the space in which the appliances remaining connected to the common venting system are located and other spaces of the building. Turn on clothes dryers and any other appliance not connected to the common venting system. Turn on any exhaust fans, such as range hoods and bathroom exhausts, so they operate at maximum speed. Do not operate a summer exhaust fan. Close fireplace dampers.
4. Place in operation the appliance being inspected. Follow the lighting instructions. Adjust thermostat so appliance will operate continuously.
5. Test for spillage at the draft hood relief opening after 5 minutes of main burner operation. Use the flame of a match or candle, or smoke from a cigarette, cigar or pipe.
6. After it has been determined that each appliance remaining connected to a common venting system properly vents when tested as outlined above, return doors, windows, exhaust fans, fireplace dampers and any other gas burning appliances to their previous condition of use.
7. Any improper operation of the common venting system should be corrected so the installation conforms with the National Fuel gas Code, ANSI Z223.1/NFPA 54. When re-sizing any portion of the common venting system, the common venting system should be re-sized to approach the minimum size determined using the appropriate tables in Chapter 13 of the National Fuel Gas Code, ANSI Z223.1/NFPA 54.

9 - VENT DAMPER INSTALLATION & INSTRUCTIONS

DAMPER INSTALLATION

NOTE: Refer to Figure 10 for steps 1-6.

Figure 11 - Damper Motor Wiring



1. Place vent damper on or as close to vent outlet of boiler as possible. See Figure 12.
2. Remove vent damper motor cover.
3. Feed damper wire harness connector through bracket hole on damper motor frame.
4. Tighten locknut onto damper wire harness connector.
5. Plug damper connector into socket on damper motor frame.
6. Replace damper motor cover and wire damper. See Figure 11.

DAMPER INSTRUCTIONS

Figure 12 - Vent Damper Placement

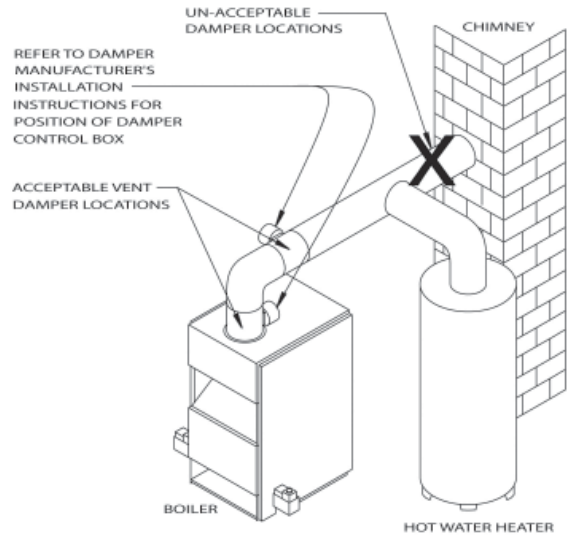

1. Verify only boiler is serviced by vent damper. See Figure 12.
2. Clearance of not less than 6 inches between vent damper and combustible material must be maintained. Additional clearance should be allowed for service of vent damper.
3. Vent damper must be in the open position when appliance main burners are operating.
4. Vent damper position indicator must be in a visible location following installation.
5. The thermostat's heat anticipator must be adjusted to match the total current draw of all controls associated with boiler during heating cycle.

CAUTION

WHAT TO DO IF YOU SMELL GAS

- Do not try to light any appliance.
- Do not touch any electrical switch; do not use any phone in your building.
- Immediately call your gas supplier from a neighbor's phone. Follow gas supplier's instructions.
- If you cannot reach your gas supplier, call the fire department.

General

- Use piping materials and joining methods acceptable to authority having jurisdiction. In absence of such requirements of National Fuel Gas Code, ANSI Z223.1/ NFPA 54
- Size and install gas piping system to provide sufficient gas supply to meet maximum input at not less than minimum supply pressure. See Table 5.
- Support piping with hooks straps, bands, brackets, hangers, or building structure components to prevent or dampen excessive vibrations and prevent strain on gas connection. Boiler will not support piping weight.
- Use thread (joint) compound (pipe dope) suitable for liquefied petroleum gas.
- Install field sourced manual main shutoff valve, ground joint union, and sediment trap upstream of gas valve. See Figure 13.

Figure 13 - Gas Piping

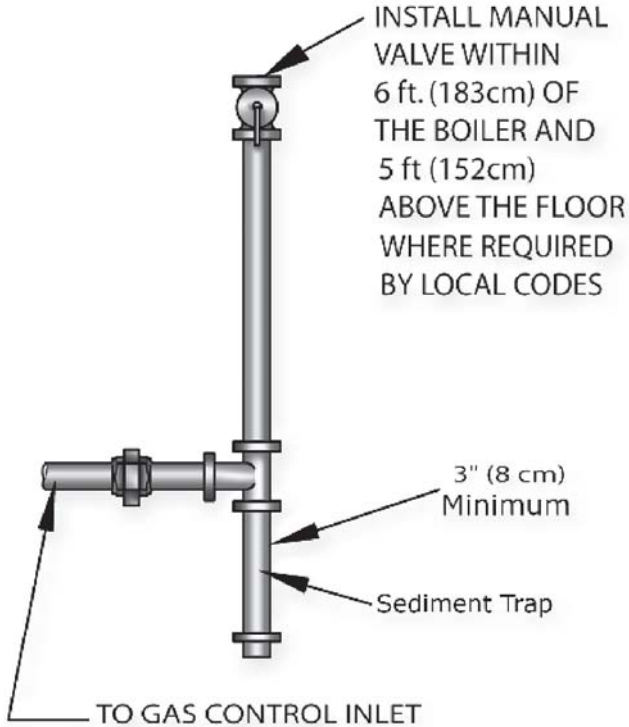

MAXIMUM CAPACITY OF PIPE IN CUBIC FEET OF GAS/HOUR
(Gas Pressure = 0.5 psig or less, Pressure Drop = 5 in. w/c)

Length of Pipe (Feet)	Nominal Iron Pipe Size			
	1/2"	3/4"	1"	1 1/4"
10	175	360	680	1400
20	120	250	465	950
30	97	200	375	770
40	82	170	320	660
60	66	138	260	530
80	57	118	220	460
100	50	103	195	400

For additional information refer to the National Fuel Gas Code Handbook.

Table 5 - Gas Pressure

	Natural Gas	Propane
Min. Supply Pressure	5" w.c.	11" w.c.
Max. Supply Pressure	13.5" w.c.	13.5" w.c.
Manifold Pressure	3.5" w.c.	10.5" w.c.

DANGER

Fire Hazard. Do not use matches, candles, open flames, or other methods providing ignition source. Failure to comply will result in death or serious injury.

Leak Check Gas Piping

Pressure test boiler and gas connection before placing boiler in operation.

- Pressure test over 1/2 psig (3.5 kPa). Disconnect boiler and its individual gas shutoff valve from gas supply system.
- Pressure test at 1/2 psig (3.5 kPa) or less. Isolate boiler from gas supply system by closing manual gas shutoff valve.
- Locate leakage using gas detector, noncorrosive detection fluid, or other leak detection method acceptable to authority having jurisdiction. Do not use matches, candles, open flames, or other methods providing ignition source.
- Correct leaks immediately and retest.

WARNING

Electrical shock hazard. Turn OFF electrical power supply at service panel before making electrical connections. Failure to do so could result in death or serious injury.

Electrical Wiring

See wiring diagrams on the following two pages for details.

Electrically bond boiler to ground in accordance with requirements of authority having jurisdiction. Refer to National Electrical Code, ANSI/NFPA 70.

Thermostat Installation

1. Thermostat should be installed on an inside wall about four feet above the floor.
2. NEVER install a thermostat on an outside wall.
3. Do not install a thermostat where it will be affected by drafts, hot or cold pipes, sunlight, lighting fixtures, televisions, a fireplace, or a chimney.
4. Check thermostat operation by raising and lowering thermostat setting as required to start and stop the burners.
5. Instructions for the final adjustment of the thermostat are packaged with the thermostat (adjusting heating anticipator, calibration, etc.)

12 - WIRING DIAGRAM - INTERMITTENT IGNITION

Figure 14 - Intermittent Electronic Ignition Control (24009076)

⚠ WARNING

Modification, substitution or elimination of factory equipped, supplied or specified components may result in personal injury or loss of life.

WIRING DIAGRAM

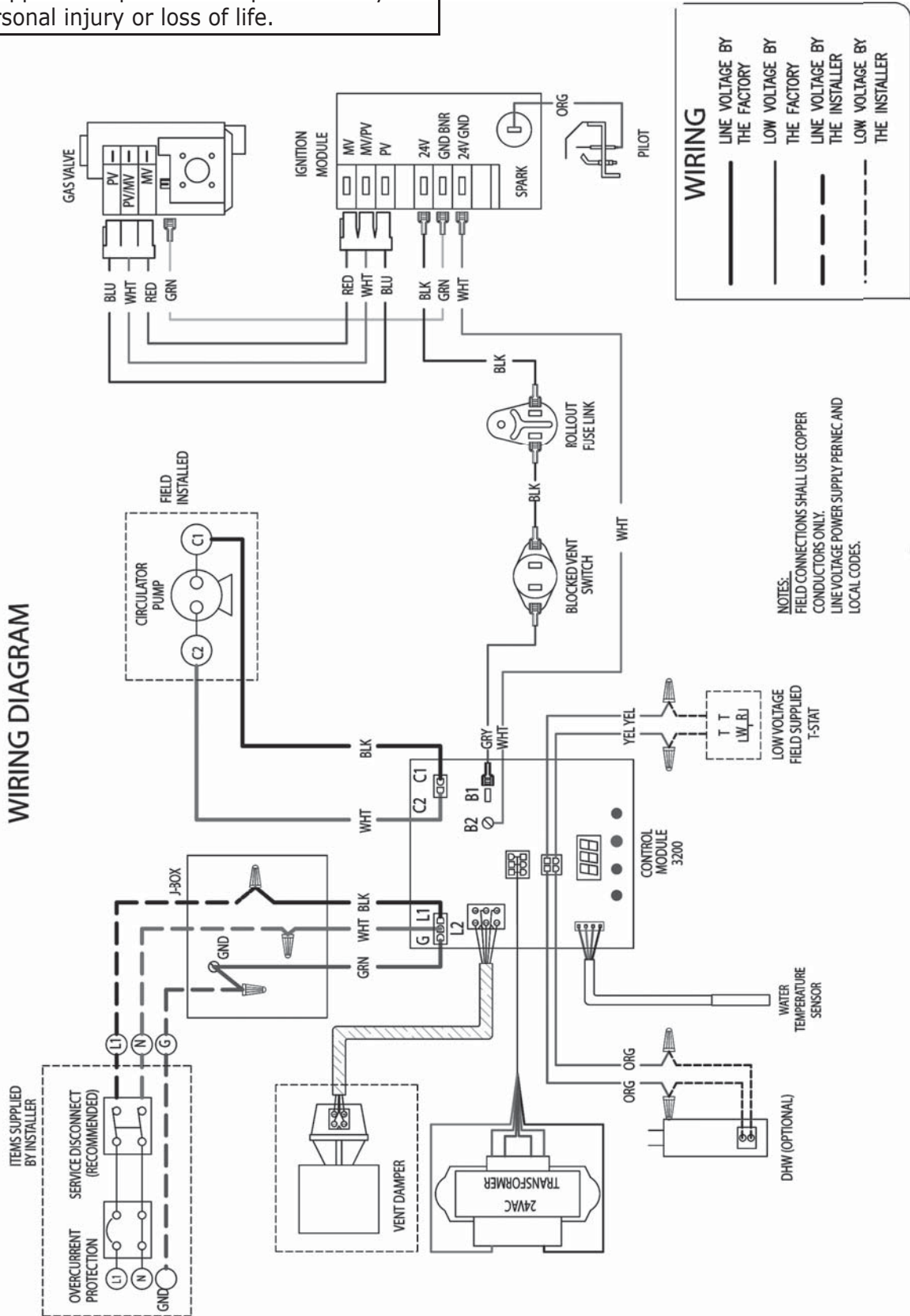

⚠ WARNING

If you do not follow these instructions exactly, a fire or explosion may result causing property damage, personal injury or loss of life.

- This appliance is equipped with an ignition device which automatically lights burner. **Do NOT try to light this burner by hand.**
- Before operating smell all around appliance area for gas. Be sure to smell next to floor because some gas is heavier than air and will settle to the floor.
- **Use only your hand to turn the gas shutoff valve.** Never use tools. If valve will not turn by hand, do not try to repair it, call a qualified service technician. Force or attempted repair may result in fire or explosion.
- **Do not use this appliance if any part has been under water.** Immediately call a qualified service technician to inspect appliance and to replace any part of control system and any gas control which has been under water.

NOTICE

Before lighting any type of pilot burner (standing or intermittent), verify the hot water boiler and system are full of water to minimum pressure of 12 psi in the system, also verify system is vented of air. Set operating control of thermostat to "below" normal setting. Refer to following appropriate lighting instruction.

LIGHTING PROCEDURE FOR BOILER WITH INTERMITTENT PILOT SYSTEM

For Your Safety, Read Before Operating!!

- A. This appliance is equipped with an ignition device which automatically lights the pilot. Do not try to light appliance by hand.

⚠ CAUTION

WHAT TO DO IF YOU SMELL GAS



- Do not try to light any appliance.
- Do not touch any electrical switches; do not use any phone in your building.
- Immediately call your gas supplier from a neighbor's phone. Follow the gas supplier's instructions.
- If you cannot reach your gas supplier, call the fire department.

OPERATING INSTRUCTIONS FOR INTERMITTENT PILOT SYSTEM

1. STOP! Read the safety information to the left.
2. Set the thermostat to lowest setting.
3. Turn off all electric power to the appliance.
4. This appliance is equipped with an ignition device which automatically lights the pilot. Do not try to light the pilot by hand.

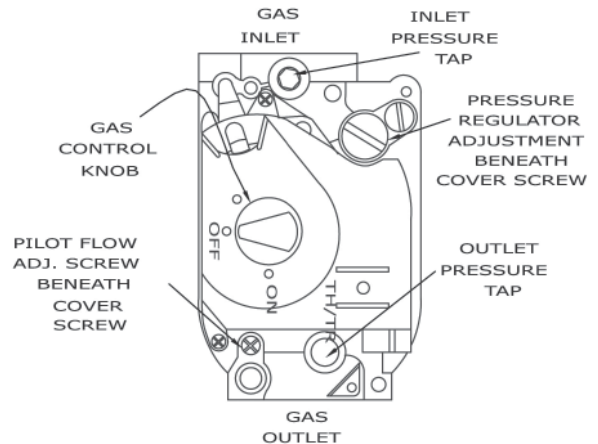
Figure 16 - Intermittent Pilot



5. Turn gas control knob clockwise  to "OFF."
6. Wait (5) minutes to clear out any gas. If you then smell gas, STOP! Follow "What To Do If You Smell Gas" in the safety information to the left. If you don't smell gas, go on to the next step.
7. Turn gas control knob counterclockwise  to "ON."
8. Turn on all electric power to the appliance.
9. Set thermostat to desired setting.
10. If the appliance will not operate, follow the instructions "To Turn Off Gas To Appliance", and call qualified service technician or your gas supplier.

TO TURN OFF GAS TO THE APPLIANCE

1. Set the thermostat to lowest setting.
2. Turn off all electric power to the appliance if service is to be performed.
3. Push in gas control knob slightly and turn clockwise  to "OFF." DO NOT FORCE.
4. Call qualified service technician.

14 - SEQUENCE OF OPERATION

Thermostat actuates on call for heat, completing circuit to control. Completed circuit to control will first activate circulator and damper which will close end switch inside damper. Completes circuit to ignition system, ignition takes place.

In event boiler water temperature exceeds high limit setting on boiler mounted high limit control, power is interrupted between control system and ignition system. Power remains off until boiler water temperature drops below high limit setting. Circulator continues to operate under this condition until thermostat is satisfied.

In event flow of combustion products through boiler venting system becomes blocked, blocked vent safety switch shuts main burner gas off. Similarly, if boiler flue-way becomes blocked, flame rollout safety switch shuts main burner gas off. See Figure 17. If either of these conditions occur, do not attempt to place boiler back into operation. Contact certified service agency.

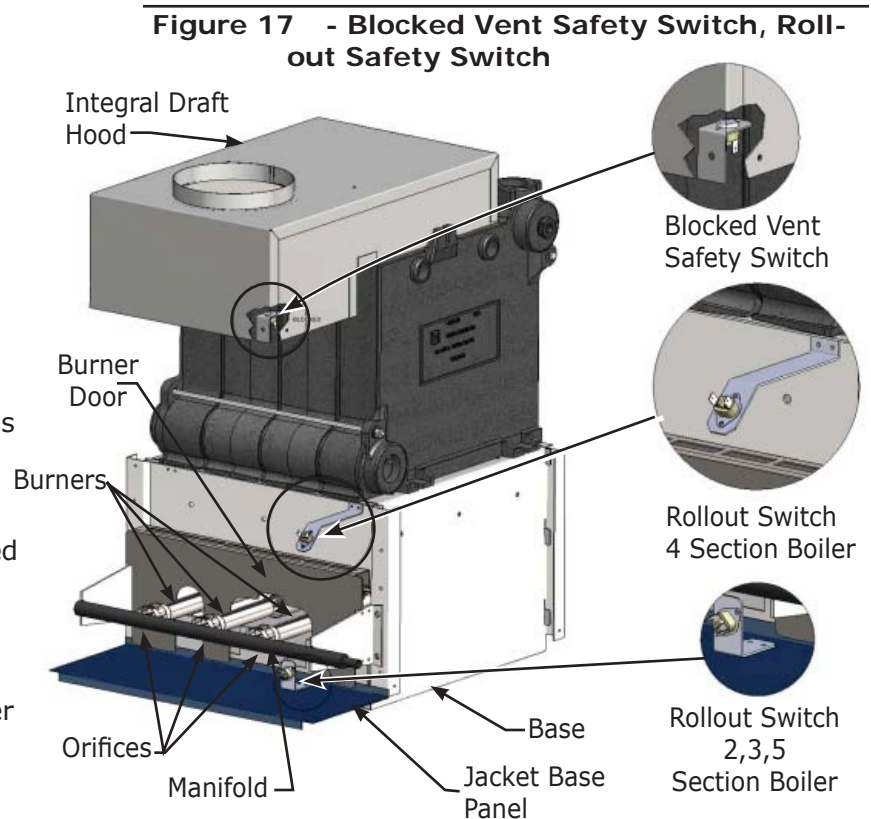

15 - GENERAL INSTRUCTIONS

Before seasonal start-up, have a certified service agency check boiler for soot and scale in flues, clean burners and check gas input rate to maintain high operating efficiency.

! WARNING

Label all wires prior to disconnection when servicing controls. Wiring errors could cause improper and dangerous operation.

Verify proper operation after servicing

Service agency will verify system is filled with water to minimum pressure and open air vents, if used, to expel any air accumulated in the system. Check entire piping system and, if any leaks appear, have them repaired.

Circulators need to be checked and maintained. Refer to circulator manufacturer's instructions.

Inspect venting system at the start of each heating season. Check vent pipe from boiler to chimney for signs of deterioration by rust or sagging joints. Repair if necessary. Remove vent pipe at base of chimney or flue and using a mirror, check vent for obstruction and verify vent is in good working order.

Boiler flue gas passageways may be inspected by a light and mirror. Remove burner door. See Figure 20, Page 20. Place trouble lamp in flue collector through draft relief opening. With mirror positioned above burners, flue gas passageways can be checked for soot or scale.

This procedure should be followed to clean flue gas passageways:

1. Remove burners from combustion chamber by raising burners up from manifold orifices and pulling toward front of boiler. See Figure 17.
2. Disconnect vent pipe from draft hood.
3. Remove top jacket panel.
4. Remove combination flue collector and draft hood from boiler castings by loosening nuts on hold down bolts located on each side of collector. See Figure 17.
5. Place sheet of heavy paper or similar material over bottom of base and brush down flue passageways. Soot and scale will collect on paper and is easily removed with the paper.
6. With paper still in place in base, clean top of boiler castings of boiler putty or silicone used to seal between castings and flue collector. Verify chips are not lodged in flue passageways.

When cleaning process is complete, restore boiler components to their original position. Use IS-808 GE silicone (available from distributor) to seal around flue collector and boiler castings.

Make visual check of main burner and pilot flames at start of heating season and again in mid-season. Main burner flame should have well defined inner blue mantel with lighter blue outer mantel. Check burner throats and burner orifices for lint or dust obstruction. See Figures 17 and 19.

Figure 18 - Gas Burner Flame

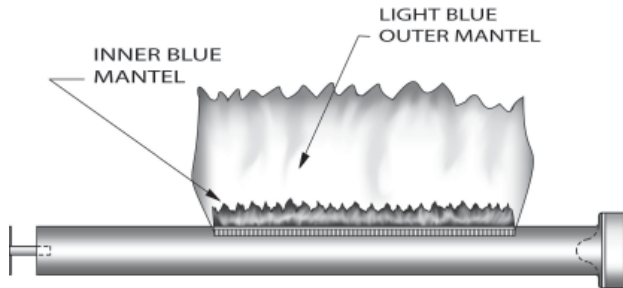

Figure 19 - Gas Burner Pilot

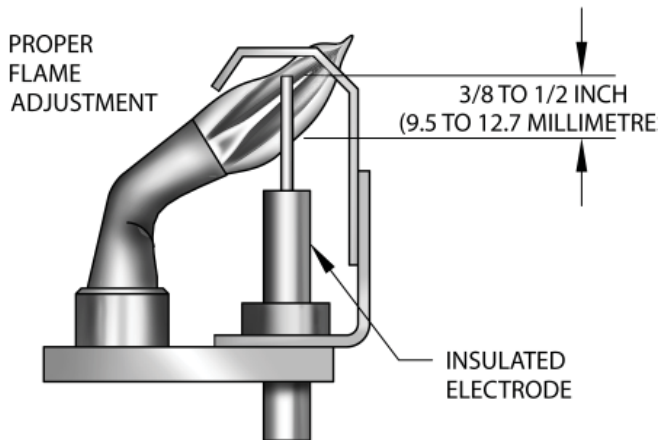
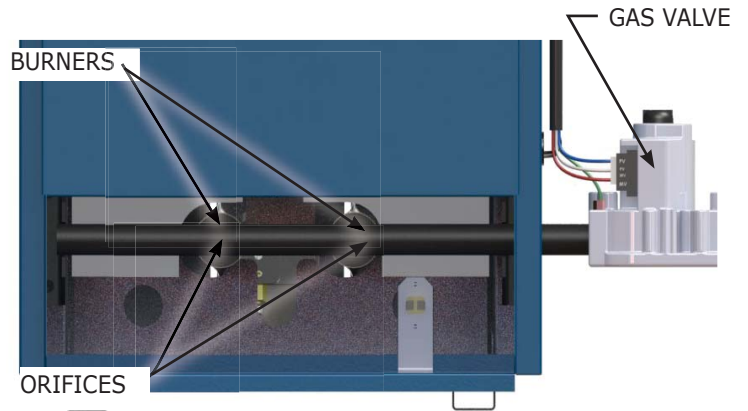



Figure 20 - Combustion Chamber



Pilot flame should envelop $\frac{3}{8}$ to $\frac{1}{2}$ inch of tip of pilot thermocouple, ignition/sensing electrode or mercury sensor. See Figure 19.

To adjust pilot flame, remove pilot adjustment cover screw and turn inner adjustment screw counterclockwise  to increase or clockwise  to decrease pilot flame.

Be sure to replace cover screw after adjustment to prevent possible gas leakage. See Figure 14, Page 16.

Burners and pilot should be checked for signs of corrosion, rust or scale buildup.

Area around boiler must be kept clear and free of combustible materials, gasoline and other flammable vapors and liquids.

Free flow of combustion and ventilating air to boiler and boiler room must not be restricted or blocked.

Inspect field sourced low water cutoffs annually, or as recommended by low water cutoff manufacturer. Flush float type low water cutoffs per manufacturer's instructions.

Employ a qualified service agency to make annual inspection of boiler and heating system. They are experienced in making the inspections outlined above, and, in event repairs or corrections are necessary, trained technicians can make the proper changes for safe operation of the boiler.

16 - CHECKING GAS INPUT RATE TO BOILER

- Adjust gas input to boiler by removing protective cap on pressure regulator, and turning screw clockwise ↻ to increase input and counterclockwise ↻ to decrease input.
- Manifold pressures are taken at outlet side of gas valve.
- To check for proper flow of natural gas to boiler, divide input rate shown on rating plate by heating value of gas obtained from local gas company. This determines number of cubic feet of gas required per hour.
- With all other gas appliances off, determine flow of gas through meter for two minutes and multiply by 30 to get hourly rate.
- Make minor adjustments to gas input as described above.
- Change burner orifices if final manifold pressure varies more than plus or minus 0.3 inches water column from specified pressure.
- Primary air adjustment is not necessary, therefore air shutters are not furnished as standard equipment.
- Air shutters can be furnished on request where required by local codes or conditions.

CHECK SAFETY CONTROL CIRCUIT. Test ignition system safety shutoff device after placing boiler in operation.

1. **Pilot:** With main burner operating, turn pilot gas adjusting screw clockwise ↻ until pilot gas is turned off. Within 90 seconds main gas control closes, shutting off gas to main burner.
2. **High Limit Control:** Remove cover and note temperature setting. Decrease this setting to minimum and operate boiler. When the boiler water temperature exceeds the control temperature setting, the control will open the circuit, closing the automatic main gas valve. See Figure 21.

Figure 21 - High Limit Control Location



Wiring An Indirect Water Heater

When installing with indirect water heater, signal from indirect must be separated from heating zone signals and wired appropriately.

If you choose not to separate indirect signal from heating zones, Economy Feature should be turned off to insure boiler supplies adequate temperature to heat the indirect tank.

Setting The Control

Settings can be checked using the TEST/SETTINGS Button. See page 23 for details.

Setting The High Limit

The high limit is factory set at 190°F. To adjust, turn HI TEMP dial **A** until desired setting is displayed. (Setting range: 130°F - 220°F)

Setting The Low Limit

Low limit is designed to maintain temperature in boiler suitable for domestic hot water. Low limit is factory set to OFF. Prior to adjusting, remove the jumper (not equipped on all units) **B**.

Then turn LO Temp dial **C** clockwise until desired temperature is displayed. For Proper operation, low temperature limit setting should be at least 10° below high limit setting. For cold start operation, low limit must be turned OFF. If low limit temperature cannot be set above 140°F, remove jumper **B**. (Setting range: OFF or 110°-200°F).

Setting The Economy Feature

Economy Feature is factory set for 1 zone heating system. To adjust, turn the ECONOMY dial **D** until the number displayed equals the number of heating zones. The Economy Feature conserves fuel by reducing boiler temperature. If heating system is unable to supply needed heat to the house, Economy dial should be turned to lower setting (example: In a three zone house, turn dial to 2 or 1). Conversely, if boiler provides adequate heat, added fuel savings can be achieved by selecting a higher setting (example: 4 or 5). If heating and indirect water heater signals were not separated when wiring control, Economy Feature should be turned OFF to insure boiler supplies adequate temperature to heat the indirect tank.

SETTING	
OFF	Disables economy function. Will allow boiler to fire until hi-limit temp is reached and re-fire with a 10° subtractive differential.
LO	Provides lowest level of fuel savings. Use this setting only if the house does not stay warm at higher settings.
1	Recommended setting for single zone systems.
2	Recommended setting for Two zone systems.
3	Recommended setting for Three zone systems.
4	Recommended setting for Four zone systems.
5	Recommended setting for Five zone systems.
HI	Provides highest level of fuel savings.

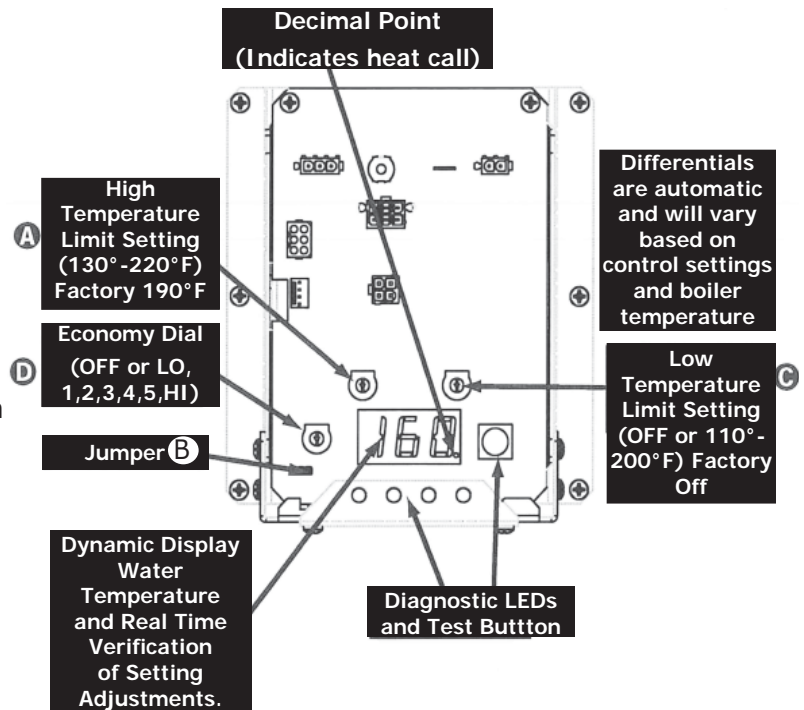

Activation Thermal Pre-Purge (Optional)

Activation of this feature is not recommended for boiler supplying domestic hot water.

Fuel Smart HydroStat has a Thermal Pre-Purge feature to maximize efficiency. When activated, control will purge higher boiler temperatures down to 135°F at start of any thermostat call and supply the latent energy in the boiler to the heating zone that is calling. During the purge cycle, the display will indicate **Pur**. If the heat is not sufficient to satisfy the thermostat, control will energize burner. Feature works with single and multi-zone heating systems utilizing circulators or zone valves. No change in wiring is needed.

To Activate Thermal Pre-Purge

Push and hold the *TEST/SETTINGS* button for 20 seconds. Display will read **Pur On**. To deactivate this feature, push and hold button a second time for 20 seconds. Display will read **Pur OFF**.

System Start-up

At initial start-up, with Economy feature active, control establishes 145°F target temperature. To test the high limit shut-off function, Economy Dial must be turned to OFF. Once tested, restore the Economy setting. If heating demand is high, target will increase over time to satisfy heat load. To reduce potential for condensing, control will allow boiler to heat to 120°F prior to energizing the circulator.

How Thermal Targeting Works

Thermal targeting technology analyzes thermostat activity and continually evaluates how much heat the house requires. When it is very cold outside, heat demand is high and Fuel Smart HydroStat will raise boiler's target temperature to provide needed heat to the home. When outside temperature is milder, heat demand is lower. During these periods, Fuel smart HydroStat will lower boiler's target temperature saving fuel while continuing to provide comfort to the house.

LED Legend



1 LOW WATER

Illuminates if boiler is in a low water condition. Control will prevent burner operation during this condition.

NOTICE

System must be checked by a qualified heating professional prior to resuming operation.

WARNING

Burn and scald hazard. Do not add water until boiler has fully cooled. Failure to follow these instructions could result in death or serious injury.

2 T-STAT

Illuminates whenever there is a call for heat from any thermostat, zone device or indirect.

3 TARGET/HI LIMIT

Illuminates when boiler temperature has reached target temperature or high limit setting. When economy feature is active, the control utilizes thermal targeting technology to operate boiler at reduced target temperatures (during off-peak demand) or at high limit setting (during peak demand). When boiler water temperature reaches the target or high limit temperature, LED illuminates and burner shuts down. Boil water continues to circulate and heat the house as long as thermostat call continues. The LED will stay lit until boiler temperature drops to predetermined differential. The LED illuminates regularly during normal operation.

4 BURNER

Illuminates whenever the burner is running (B1 is powered).

Test/Settings Button

To test low water cut-off: Press and hold TEST/SETTINGS button for 5 seconds. Display will read LCO.



The red Low Water light should illuminate and burner circuit (B1 and B2) should energize.

To View Current Settings: Press and release the TEST/SETTINGS button in short intervals to sequentially display following settings:

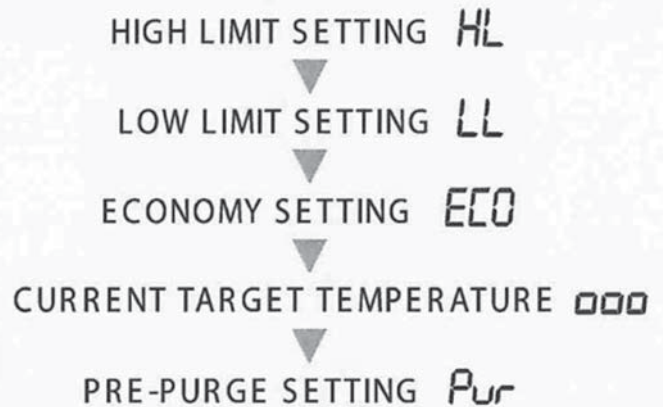

The display will return to boiler temperature (default) if TEST/SETTINGS button is not pressed for 5 seconds.

17 - OPERATING THE BOILER - LIMIT CONTROL TROUBLESHOOTING

Fahrenheit/Celsius Change

Control has the ability to operate in degrees Fahrenheit (default setting) or Celsius.

To change from Fahrenheit to Celsius:

1. Set low limit to 112°F
2. Set high limit to 112°F
3. Display will delay 2 seconds and then display an "F".
4. Push the LWCO Test Button to change setting to "C".
5. Reset the limit dials to the correct settings.

When control is in Celsius mode, a "c" appears in temperature display as third digit whenever temperature is below 100°C.

To change from Celsius to Fahrenheit:

1. Set low limit to 44°C.
2. Set high limit to 44°C.
3. Display will delay 2 seconds and then display a "c".
4. Push the LWCO test button to change settings to "F".
5. Re-set limit dials to correct settings.

WARNING

Burn and scald hazard. Do not add water until boiler has fully cooled. Failure to follow these instructions could result in death or serious injury.

Table 6 - LIMIT CONTROL TROUBLESHOOTING

Temperature Display Exceeds High Limit Setting	Under normal operation, boiler temperature continues to rise after control shuts off the burner. This condition, known as "thermal stacking", results from hot boiler surfaces continuing to release heat into the boiler.
No Domestic Hot Water from Tankless Coil	Make sure low limit setting on Control is properly set. If low limit setting is dialed fully counter clockwise, it shuts off the low temperature maintenance feature.
Boiler will Not Maintain Low Limit Temperature	Check for overlapping high temperature setting. If high limit setting is below low limit setting, control will default to high limit setting.
Temperature Display Differs from Boiler Temperature Pressure Gauge Temperature Reading	Temperature variances can result from differing water temperatures within the boiler or different reaction times of the two devices. If the control temperature is significantly below the temperature pressure gauge temperature, make sure the thermistor is inserted all the way to the end of the well. DO NOT USE ANY HEAT TRANSFER PASTE OR GREASE.
TSTAT Light (Green LED) is Not On	The TSTAT light indicates when there is a call for heat. If a call is known to be present and this light is on, check the wiring to the T-T terminals.
Low Water Light (RED LED) is On	<p>READ WARNING ABOVE. Low water condition is a serious and potentially dangerous condition. Do not attempt to add water to a hot boiler. Allow boiler to fully cool before adding water.</p> <ol style="list-style-type: none"> 1. If heating system is filled with water, pull sensor out of well and inspect it. Verify the metal clip on the sensor is intact. This metal clip must be in contact with the inside of the copper well in order for control to sense presence of water. Check well does not have excessive build-up of heat transfer grease that may interfere with clip contacting well. 2. Remove well and examine for excessive residue build-up. Clean and re-install.

TABLE 7 - SYSTEM TROUBLESHOOTING

No Or Insufficient Domestic Hot Water	If installed with indirect water heater, insure end switch in relay box controlling indirect water heater is properly connected to cable 2 (see wiring diagram). This insures domestic water calls are prioritized. If cable 2 is not used, turn Economy Feature OFF.
House Will Not Get Or Stay Warm	<ol style="list-style-type: none"> 1. Check for air bond radiators. 2. Check thermostat settings including het anticipator settings (common on non-digital thermostats). 3. Check Economy settings. Economy feature, much like outdoor reset controls, lowers average boiler temperature, can slow or prevent house from coming up to temperature. Move to lower setting.



DUNKIRK BOILERS

2201 Dwyer Avenue, Utica NY 13501
web site: www.ecrinternational.com