

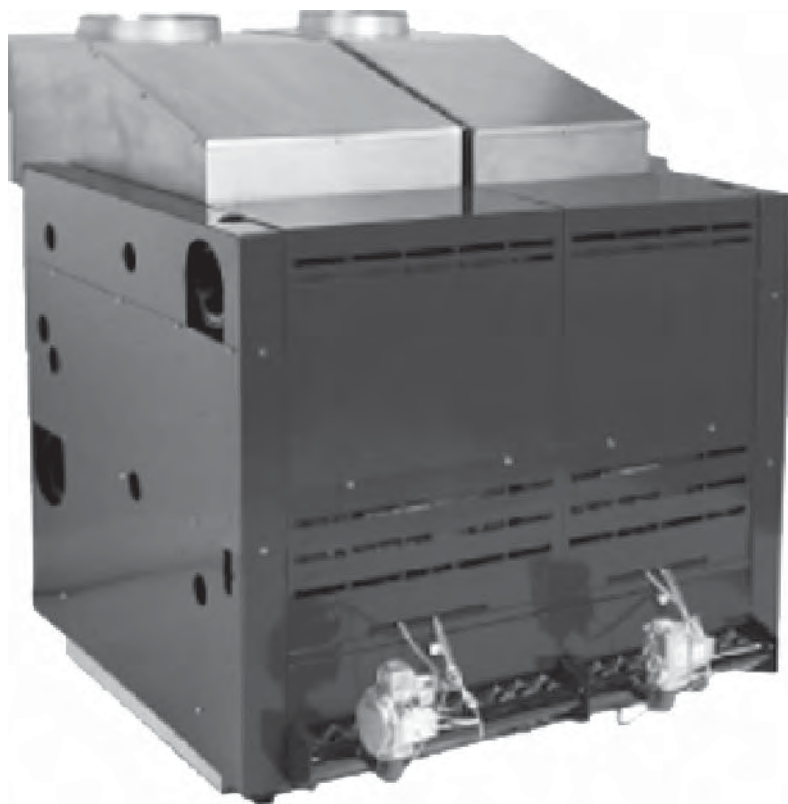

# D248 Series

## Cast Iron Commercial Steam Boiler

### INSTALLATION, OPERATION & MAINTENANCE MANUAL



**Manufactured by:**  
**ECR International, Inc.**  
2201 Dwyer Avenue, Utica NY 13501  
web site: [www.ecrinternational.com](http://www.ecrinternational.com)

P/N# 240009137, Rev. A [02/2012]

INSTALLATION MANUAL AND OPERATING INSTRUCTIONS

TABLE OF CONTENTS

Safety Symbols ..... 2  
 Boiler Ratings & Capacities ..... 3  
 Rules For Safe Installation & Operation..... 4  
 Locating The Boiler ..... 5  
 Combustion Air, Chimney & Vent Pipe Connection ... 5  
 Minimum Vent Pipe Clearance, ..... 5  
 Installation ..... 5  
 Ventilation And Combustion Air ..... 6  
 Vent Installation ..... 8  
 Assembly Of Bases, Starting Section Assembly ..... 12  
 Attaching Draft Hoods..... 13  
 Installing Boiler Jacket Panels ..... 14  
 Control Mounting And Installation ..... 17  
 Tappings ..... 19  
 Boiler Trim, Water Trim, Water Trim Assembly..... 19  
 Boiler Piping ..... 20  
 Boilers Used With Refrigeration System ..... 20  
 Boiler Piping, High Limit, Pipe Sizing..... 20  
 Piping Diagrams ..... 21  
 Connecting Gas Service..... 23  
 Electrical Wiring ..... 24  
 Installing Thermostat ..... 24  
 Adjust Thermostat Heat Anticipator ..... 24  
 Stage Firing Multiple Base Boilers ..... 24  
 Wiring Diagrams ..... 25  
 Operation and Service ..... 27  
 Functions & Operation, Trial/Pilot Ignition ..... 27  
 Main Burner Operation, System Troubleshooting ..... 27  
 Component & Spark Ignition Check..... 27  
 Startup & Checkout, Start system..... 28  
 Pilot Flame Adjustment, Check Burner Input..... 28  
 Pilot System Troubleshooting Table ..... 29  
 Checking & Adjusting ..... 30  
 Cleaning And Maintenance ..... 31

SAFETY SYMBOLS

 **DANGER**

Indicates a hazardous situation which, if not avoided, WILL result in death or serious injury.

 **WARNING**

Indicates a hazardous situation which, if not avoided, could result in death or serious injury.

 **CAUTION**

Indicates a hazardous situation which, if not avoided, could result in minor or moderate injury.

**NOTICE**

Indicates information which should be followed to ensure proper installation and operation.

**KEEP THIS MANUAL NEAR BOILER.  
 RETAIN FOR FUTURE REFERENCE.**

 **WARNING**

Fire, explosion, asphyxiation and electrical shock hazard. Improper installation could result in death or serious injury. Read this manual and understand all requirements before beginning installation.

## RATINGS AND CAPACITIES

 <span style="float: right;">Ratings and Capacities - Chart 1</span>												
Input/Size (Mbh)	Output (1)	Net AHRI Ratings (2)		Flue Outlet No. & Size			Chimney Size (6)	Flue Collector Size to Chimney	Horsepower Gross Output (4)	Therm. Eff.	Pressure Drop Thru Water Boiler (5)	
	Gross Output Mbh	Steam (Sq Ft)	Steam Mbh	8"	10"	12"	I.D. x Ht.				GPM	In. Water
300	233	729	175	1			8"x20'	8	6.96	77.5	18.9 37.8	0.10 0.50
400	310	971	233		1		10"x20'	10	9.25	77.5	25.2 50.4	0.27 0.86
500	388	1213	291			1	12"x20'	12	11.58	77.5	31.5 63.0	0.40 1.20
600	465	1454	349	2			12"x20'	12	13.88	77.5	37.8 75.6	0.50 1.70
700	543	1696	407	1	1		12"x20'	12	16.21	77.5	44.1 88.2	0.70 2.50
800	620	1938	465		2		14"x20'	14	18.51	77.5	50.4 100.8	0.88 2.90
900	698	2183	524		1	1	14"x20'	14	20.84	77.5	56.7 113.4	1.10 3.80
1000	775	2421	581			2	14"x20'	14	23.13	77.5	63.0 126.0	1.30 4.00
1100	853	2667	640	1	2		16"x20'	16	25.46	77.5	69.3 138.6	1.50 5.00
1200	930	2908	698		3		16"x20'	16	27.76	77.5	75.6 151.2	1.80 6.00
1300	1008	3150	756	1		2	16"x20'	16	30.09	77.5	81.9 163.8	2.00 5.60
1400	1085	3392	814		1	2	18"x20'	18	32.39	77.5	88.2 176.4	2.40 7.00
1500	1163	3633	872			3	18"x20'	18	34.72	77.5	94.5 189.0	2.60 8.30
1600	1240	3875	930		4		18"x20'	18	37.01	77.5	100.8 201.0	2.80 9.60
1700	1318	4138	993	1	1	2	18"x20'	18	39.34	77.5	107.1 214.2	3.15 10.30
1800	1395	4408	1058		2	2	20"x20'	20	41.64	77.5	113.4 226.8	3.50 11.00
1900	1473	4675	1122		1	3	20"x20'	20	43.97	77.5	119.7 239.4	4.00 12.50
2000	1550	4942	1186			4	20"x20'	20	46.27	77.5	126.0 252.0	4.50 14.00
2100	1628	5213	1251	2		3	20"x20'	20	48.60	77.5	132.3 264.6	4.95 16.00
2200	1705	5483	1316		3	2	22"x20'	22	50.90	77.5	138.6 277.2	5.40 18.00
2300	1783	5750	1380		2	3	22"x20'	22	53.22	77.5	144.9 289.8	5.70 17.00
2400	1860	6008	1442		1	4	22"x20'	22	55.52	77.5	151.2 302.4	8.00 19.00
2500	1938	6271	1505			5	22"x20'	22	57.85	77.5	157.5 315.0	8.00 20.50
2600	2015	6517	1564	2		4	22"x20'	22	60.15	77.5	163.8 327.6	7.00 24.00
2700	2093	6771	1625	1	1	4	24"x20'	24	62.48	77.5	170.1 340.2	7.50 24.00
2800	2170	7021	1685		2	4	24"x20'	24	64.78	77.5	176.4 352.8	8.00 26.00
2900	2248	7271	1745		1	5	24"x20'	24	67.10	77.5	182.75 365.5	8.50 27.50
3000	2325	7521	1805			6	24"x20'	24	69.40	77.5	189.1 378.2	9.00 9.00

- 1) Ratings are at sea level to 2,000 feet. For altitudes above 2,000 feet, reduce all ratings 4% for each 1,000 feet above sea level
- 2) Net steam ratings based on an allowance of 1.333 (300-1600), 1.327 (1700), 1.319 (1800), 1.313 (1900), 1.307 (2000), 1.301 (2100), 1.296 (2200), 1.292 (2300), 1.290 (2400), and 1.288 (2500-3000). Contact Technical Support before selecting boiler for installations having unusual piping and pick-up factors, such as intermittent system operations, extensive piping systems, etc.
- 3) Ratings in square feet are computed at 240 Btuh/square foot for steam boilers.
- 4) Ratings based on 33,500 Btuh per horsepower.
- 5) Pressure drop based on given flow from single outlet and returning to single inlet at the opposite end of the boiler.
- 6) Chimney sizes shown are one option based on a typical venting system as shown in **Figure 6**, and sized according to the National Fuel Gas Code, assuming Type B double wall vent and vent connectors. Other venting system designs are acceptable as shown on **Flue Connection And Venting section of this manual**. For further chimney design and sizing information, consult the National Fuel Gas Code, ANSI Z223.1/NFPA 54-latest revision, or ASHRAE6 HVAC Systems and Equipment Handbook, Chimney, Gas Vent, and Fireplace Systems, or the Standard for Chimneys, Fireplaces, Vents, and Solid Fuel Burning Appliances. NFPA 211. Follow standard engineering practice.

**Safety Information**

**IMPORTANT: Read the following instructions COMPLETELY before installing!!**

**⚠ WARNING**

Fire, explosion, asphyxiation and electrical shock hazard. Improper installation could result in death or serious injury. Read this manual and understand all requirements before beginning installation.

**⚠ WARNING**

Keep boiler area clear and free from combustible materials, gasoline and other flammable vapors and liquids.  
 DO NOT obstruct air openings to the boiler room. Modification, substitution or elimination of factory equipped, supplied or specified components may result in personal injury or loss of life.  
 TO THE OWNER - Installation and service of this boiler must be performed by a qualified installer.  
 TO THE INSTALLER - Leave all instructions with boiler for future reference.  
 When this product is installed in the Commonwealth of Massachusetts the installation must be performed by a Licensed Plumber or Licensed Gas Fitter.

1. Never test for leaks with an open flame. Use soap suds to check all connections. This will avoid any possibility of fire or explosion.
2. Boiler is configured for operation with natural gas. Over-firing will result in premature failure of boiler sections and cause dangerous operation. Verify there is adequate gas supply piping.
3. Never vent this boiler into enclosed space. Always connect boiler to chimney and vent to outside. Never vent to another room or inside abuilding.
4. Verify there is adequate air supply for complete combustion.
5. Follow regular service and maintenance schedule for efficient and safe operation.

**⚠ WARNING**

Fire hazard. Do not install boiler carpeting. Failure to follow these instructions could result in death or serious injury.

6. Never install boiler on carpeting.

**When Your Boiler Arrives**

When boiler arrives be sure to save and refer to instructions.

Inspect each item received for visible damage. If any parts are damaged, report this to freight company immediately and request them to call and make inspection before you make any installation. Have inspector prepare a signed report. Send copy of report to manufacturer.

We must have the signed inspection report of the freight company to prove their liability.

Read these instructions carefully before beginning the installation to be sure all packages have been received. It is recommended that you follow the step-by-step instructions for best assembly results. Before discarding any packing material carefully examine for loose parts. Also store all parts received where they will not be lost or damaged.

**CODES GOVERNING INSTALLATION**

Installation must conform to the requirements of the authority having jurisdiction or, in the absence of such requirements, to the National Fuel Gas Code, ANSI Z223.1/NFPA54.

Where required by the authority having jurisdiction, the installation must conform to the standard for Controls and Safety Devices for Automatically Fired Boilers, ANSI/ASME CSD-1.

**Installation**

Boiler is designed to provide wide heating capacity range with multiple burner modules, each equipped with its own set of controls. For purposes of orientation, gas manifold side of boiler is considered front. Instructions are written for assembly of boiler starting with left side and working to right side.

Hot water boiler installed above radiation level or as required by the Authority having jurisdiction, must be provided with a low water cutoff device at the time of boiler installation.

**Boiler Location**

Locate boiler on level, non-combustible foundation as near to chimney or flue as possible. Allow 24 inches at front and sides of boiler for servicing and cleaning. When installed in utility room, the door should be wide enough to allow the largest boiler parts to enter, or permit replacement of any other appliance in the same room.

Installing contractor **must** provide ventilated foundation for boiler when installing:

- Over a room
- Over electrical wiring or cables of any kind
- If concrete floor is “green,” or water is channeled under concrete floor

**Combustion Air**

Provide combustion and ventilation air in accordance with the section “Air for Combustion and Ventilation”, of the National Fuel Gas Code, ANSI Z223.1/NFPA 54, or applicable provisions of the local building codes.

**Chimney And Vent Pipe Connection**

This is a very important part of the heating system. It must be clean, the right size, properly constructed and in **Good Condition**. No boiler can function properly with a bad chimney. See Pages 6-10 for specific venting instructions.

Flue pipe should be same size as draft hood outlet from boiler to flue collector. See **Chart 1** for Typical Chimney Size. Maintain a minimum upward slope of 1/4 inch per linear foot from boiler to the chimney. Fasten joints together with sheet metal screws to prevent sagging.

**Minimum Vent Pipe Clearance**

If the vent pipe must go through a crawl space, double wall vent pipe should be used. Where vent passes through a combustible wall or partition, use a ventilated metal thimble. The thimble should be 4 inches larger in diameter than vent pipe. If boiler is installed with single wall galvanized type vent pipe, it must have 6 inches clearance between its surface and any combustible material. If UL listed type B (insulated) vent pipe is used, clearance between it and combustible material to be as listed by pipe manufacturer.

<b>FOR INSTALLATION ON NON-COMBUSTIBLE FLOORS ONLY, MINIMUM CLEARANCES TO COMBUSTIBLE CONSTRUCTION</b>		
	<b>Inputs of 400 MBH or less</b>	<b>Inputs over 400 MBH</b>
Top	52"	52"
Front	Alcove	Alcove
Flue Collector	6 "	6"
Rear	18"	24"
Sides	18"	24"
Steam/Water Piping	1"	1"

Greater clearances (24") for access should supersede fire protection clearances.

## VENTILATION AND COMBUSTION AIR

### ⚠ WARNING

Asphyxiation hazard. Ensure enough air is available for proper combustion, avoiding hazard due to lack of oxygen.

### ⚠ WARNING

Air openings to combustion area must not be obstructed. Follow Chart 2 to insure adequate combustion air is maintained.

### COMBUSTION AIR REQUIREMENTS – Chart #2

(MINIMUM SQUARE INCHES OPENING)

MODEL NUMBER	NUMBER OF MODULES	*UNCONFINED AREA		**CONFINED AREA OUTSIDE COMBUSTION AIR	
		OUTSIDE COMBUSTION AIR 1 SQ. IN /4000 Btu/hr (SEE FIG. 2)	INSIDE COMBUSTION AIR 1 SQ. IN. /1000 Btu/hr (SEE FIG. 1)	VERT. DUCTS 1 SQ. IN. /4000 Btu/hr	HORZ. DUCTS 1 SQ. IN. /2000 Btu/hr
300	1	75	300	75	150
400	1	100	400	100	200
500	1	125	500	125	250
600	2	150	600	150	300
700	2	175	700	175	350
800	2	200	800	200	400
900	2	225	900	225	450
1000	2	250	1000	250	500
1100	3	275	1100	275	550
1200	3	300	1200	300	600
1300	3	325	1300	325	650
1400	3	350	1400	350	700
1500	3	375	1500	375	750
1600	4	400	1600	400	800
1700	4	425	1700	425	850
1800	4	450	1800	450	900
1900	4	475	1900	475	950
2000	4	500	2000	500	1000
2100	5	525	2100	525	1050
2200	5	550	2200	550	1100
2300	5	575	2300	575	1150
2400	5	600	2400	600	1200
2500	5	625	2500	625	1250
2600	6	650	2600	650	1300
2700	6	675	2700	675	1350
2800	6	700	2800	700	1400
2900	6	725	2900	725	1450
3000	6	750	3000	750	1500

\* Unconfined area: A space whose volume is not less than 50 cubic feet per 1000 Btu per hour of all appliances installed in that space (cubic feet of space = height x width x length).

\*\* Confined area: A space whose volume is less than 50 cubic feet per 1000 Btu per hour of all appliances installed in that space (cubic feet of space = height x width x length).

Figure 1

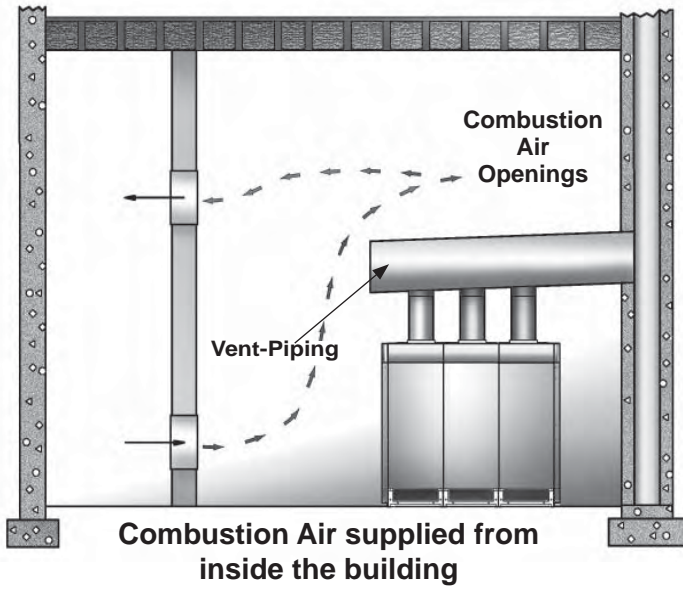
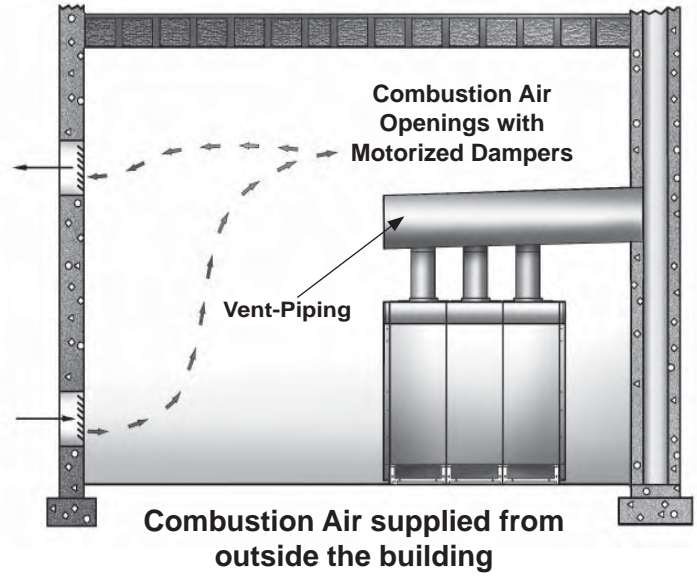

Figure 2



**Important Vent-Piping Note: Sloped vent pipe at least 1/4" for every 1' to the vent terminal.**

1. Provide combustion and ventilation air in accordance with the section "Air for Combustion and Ventilation", of the National Fuel Gas Code, ANSI Z223.1/NFPA 54, or applicable provisions of the local building codes.
2. Boiler is located in unconfined space in building or conventional construction frame, masonry or metal building, infiltration normally is adequate to provide air for combustion and ventilation. However, if equipment is located in building of tight construction (See National Fuel Gas Code, ANSI Z223.1), boiler area should be considered as confined space. If there is any doubt, install air supply provisions in accordance with latest revision of National Fuel Gas Code.
3. Boiler is installed in unconfined space, in building of tight construction, air for combustion and ventilation must be obtained from outdoors or from spaces freely communicating with outdoors. Permanent opening or openings having total free area of not less than 1 square inch per 5,000 Btu per hour of total input rating of all appliances shall be provided. Ducts may be used to convey makeup air from outdoors and shall have same cross-sectional area of openings to which they are connected.
4. When air for combustion and ventilation is from inside buildings, confined space shall be provided with two permanent openings, one starting 12 inches from top and one 12 inches from bottom of enclosed space. Each opening shall have minimum free area of 1 square inch per one thousand (1000) Btu per hour of total input rating of all appliances in enclosed space, but must not be less than one hundred (100) square inches. Openings must freely communicate directly with other spaces of sufficient volume so combined volume of all spaces meets criteria for unconfined space. **Figure 1.**
5. When boiler is installed in confined space and all air is provided from outdoors confined space shall be provided with one or two permanent openings according to methods A or B (listed below). When ducts are used, they shall be of same cross sectional area as free area of area of openings to which they connect. Minimum dimension of rectangular air ducts shall be not less than 3 x 3 inches or 9 square inches.

## VENTILATION AND COMBUSTION AIR

- A. When installing two openings, one must commence within 12 inches from top and other within 12 inches from bottom of enclosure. Openings shall communicate directly, or by ducts, with outdoors or spaces (crawl or attic) that freely communicate with outdoors. One of following methods must be used to provide adequate air for ventilation and combustion.
- 1) When directly communicating with outdoors, each opening shall have minimum free area of 1 square inch per 4,000 Btu per hour of total input rating of all equipment in enclosure. Refer to **Figure 2** on previous page.
  - 2) When communicating with outdoors by means of vertical ducts, each opening shall have minimum free area 1 square inch per 4,000 Btu per hour of total input rating of all appliances in the enclosed space.
  - 3) If horizontal ducts are used, each opening and duct shall have minimum free area 1 square inch per 2,000 Btu per hour of total input rating of all appliances in the enclosed space.
- B. One permanent opening, commencing within 12 inches of top of enclosure, shall be permitted where equipment has clearances of at least 1 inch from sides, 1 inch from back, and 6 inches from front of boiler. Opening shall directly communicate with outdoors or shall communicate through vertical or horizontal duct to outdoors or spaces (crawl or attic) that freely communicate with outdoors. Openings must have minimum free area of 1 square inch per 3000 Btu per hour of total input rating of all equipment located in enclosure. Free area must be no less than sum of areas of all vent connectors in confined space.
6. In calculating free area using louvers, grilles or screens for above, consideration shall be given to their blocking effect. Screens used shall not be smaller than 1/4 inch mesh. If free area through design of louver or grill is known, it should be used in calculating size opening required to provide free area specified. If design and free area is not known, it may be assumed that wood louvers will have 20-25% free area and metal louvers and grilles will have 60-75% free area. Louvers and grilles should be fixed in open position or interlocked with boiler so they are opened automatically during boiler operation.

## VENT INSTALLATION

### **WARNING**

Vent connectors serving appliances vented by natural draft shall not be connected into any portion of mechanical draft systems operating under positive pressure.

1. The vent pipe must slope upward from the boiler not less than 1/4" for every 1' to the vent terminal.  
**Figures 1 & 2.**
2. Horizontal portions of the venting system shall be supported rigidly every 5 feet and at the elbows. No portion of the vent pipe should have dips or sags.
3. Consult dimensional drawing for number and size of flue pipes required for each size boiler.
4. Maintain minimum upward slope of 1/4 inch per linear foot from the boiler to chimney.
5. Run flue pipe directly as possible. Keep turns to a minimum. Insert flue pipe into, but not beyond, inside wall of chimney. Do not connect into a chimney serving an open fireplace.
6. Insulate flue pipe where it passes near combustible material.
7. Rigidly support pipe with hangers and straps.
8. Extend chimneys at least 2 feet above any object within radius of 15 feet, including roof.
9. Install hood on all flue pipes which extend through roof. In most locations, venting of boiler relies on natural draft. In as much as energy available from natural draft is quite low, serious thought should be given to vent system design, i.e., adequate size, use of gradual transitions, tees, elbows, etc., close proximity of boiler and chimney. On all boilers, vertical risers must be at least as large as vent openings on draft-hood. Boiler manufacturer makes no specific recommendations regarding application of draft inducers that may be used with this boiler. If draft inducer is used, it is up to installing contractor and draft inducer manufacturer to determine proper application.



**Flue Connection And Venting** - Continued

Simple vent system consists of 6-foot minimum vertical rise immediately off draft-hood, as shown in **Figure 3**. Terminate this vertical flue above building roof with suitable rain cap at least 2 feet above surrounding obstructions, i.e., parapets, adjacent buildings, penthouses, etc. This type of vent system applies to single draft-hood boilers ONLY, and has limited practical use, because it is restricted to single-story boiler rooms and because of problems encountered in roof flashing.

Vertical venting system shown in **Figure 3** cannot be used on multiple-base boilers because of physical interference of multiple rain caps.

For multiple-base boilers, pant leg venting system shown in **Figure 4** can be applied, if desired.

Vent system shown in **Figure 5** is commonly used. With vent diameters sized to match flue outlets, minimum vertical rise of 4 feet above draft-hood must be maintained for proper operation. Refer to **Chart 1** for typical chimney sizes. Requirements for this type of system are: an adequately sized chimney, adequate combustion air, and outlet end of horizontal run must be no more than 6 feet from chimney with no more than one 90° elbow in this run as shown.

For installations where required minimum 4-foot vertical rise cannot be maintained, diameter of horizontal run must be increased one inch for each foot of riser reduction. This procedure will reduce resistance of system, and if chimney is adequate boiler will vent properly.

**Figure 3**

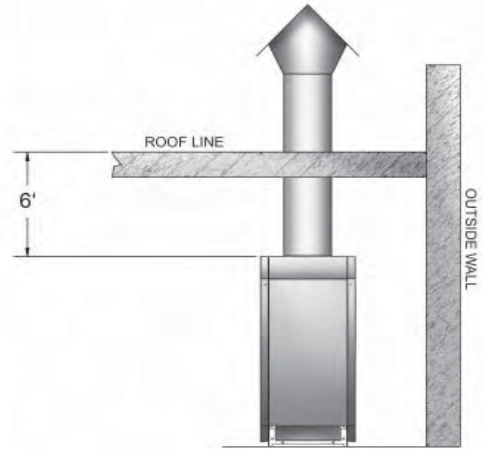

**IMPORTANT:** Extend chimneys at least 2 feet above any object within radius of 15 feet, including roof.

**Figure 5**

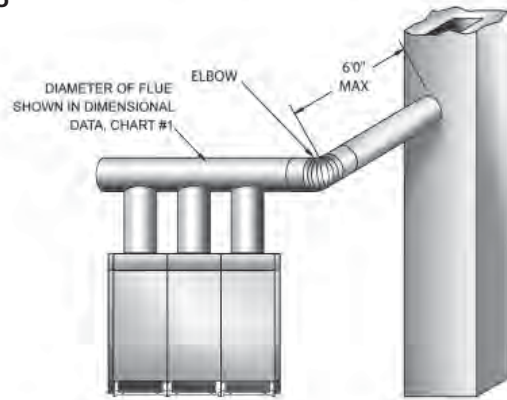

**IMPORTANT:** Extend chimneys at least 2 feet above any object within radius of 15 feet, including roof.

**Figure 4**

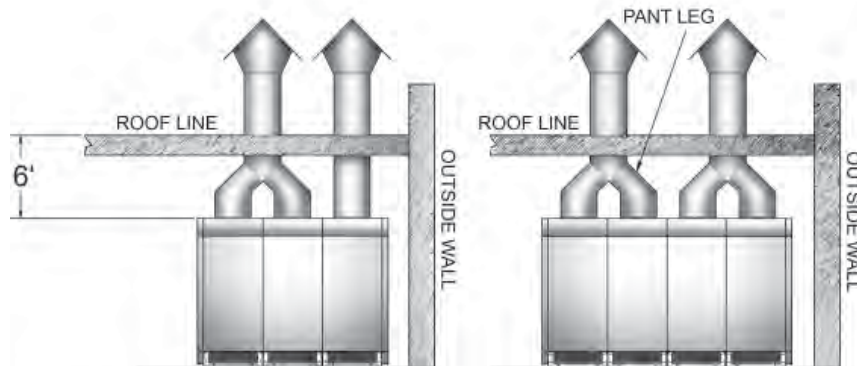

**IMPORTANT:** Extend chimneys at least 2 feet above any object within radius of 15 feet, including roof.

Figure 6

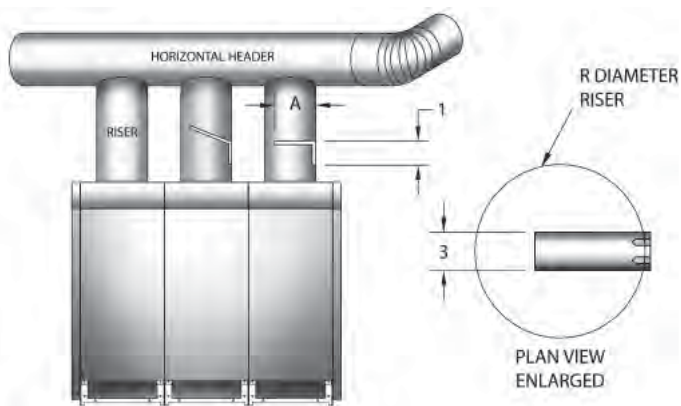

Baffle Size (Inches)			
R	8	10	12
A	6	8	10

Shown is suggested size of fixed baffle for different size risers.

**IMPORTANT:** Extend chimneys at least 2 feet above any object within radius of 15 feet, including roof.

### Flue Connection And Venting - Continued

In certain cases where these short rises of less than 4 feet have been used, spillage of combustion products has occurred at the draft-hoods farthest from the chimney. Assuming the chimney is adequately sized, one acceptable method to correct this spillage problem is to permanently baffle the riser(s) closest to the chimney to reduce the excess of room air entering those draft-hoods. **DO NOT BAFFLE ENOUGH TO CAUSE SPILLAGE.** The use of fixed baffles in the short risers above the boiler draft-hood are acceptable as spelled out in American National Standard NFPA 54/ANSI Z223.1 National Fuel Gas Code, latest revision.

Fabricate these fixed baffles, using 20-gauge steel. See Figure #6. Permanently attach the baffle to the inside of the riser(s). Trial and error will dictate the degree to which each should be positioned to avoid draft-hood spillage at the far end of the boiler. Be careful to avoid bending the fixed baffle so it will obstruct the flue gas flow in the horizontal collector.

### Removing Existing Boiler From Common Venting System

When existing boiler is removed from common venting system, common venting system is likely to be too large for proper venting of appliances remaining connected to it.

At time of removal of existing boiler, following steps shall be followed with each appliance remaining connected to common venting system placed in operation, while other appliances remaining connected to common venting system are not in operation.

1. Seal any unused openings in the common venting system.
2. Visually inspect the venting system for proper size and horizontal pitch and determine there is no blockage or restriction, leakage, corrosion and other deficiencies which could cause an unsafe condition.
3. Insofar as is practical, close all building doors and windows and all doors between the space in which the appliances remaining connected to the common venting system are located and other spaces of the building. Turn on clothes dryers and any appliance not connected to the common venting system. Turn on any exhaust fans, such as range hoods and bathroom exhausts, so they will operate at maximum speed. Do not operate a summer exhaust fan. Close fireplace dampers.
4. Place in operation the appliance being inspected. Follow the lighting instructions. Adjust thermostat so appliance will operate continuously.
5. Test for spillage at the draft hood relief opening after 5 minutes of main burner operation. Use the flame of a match or candle, or smoke from a cigarette, cigar or pipe.
6. After it has been determined that each appliance remaining connected to the common venting system properly vents when tested as outlined above, return doors, windows, exhaust fans, fireplace dampers and any other gas-burning appliance to their previous conditions of use.
7. Any improper operation of the common venting system should be corrected so the installation conforms with the National Fuel Gas Code, ANSI Z223.1/NFPA 54. When resizing any portion of the common venting system, the common venting system should be resized to approach the minimum size as determined using the appropriate tables in Chapter 13 of the National Fuel Gas Code, ANSI Z223.1/NFPA 54.

## BOILER DIMENSIONS

**Front View**

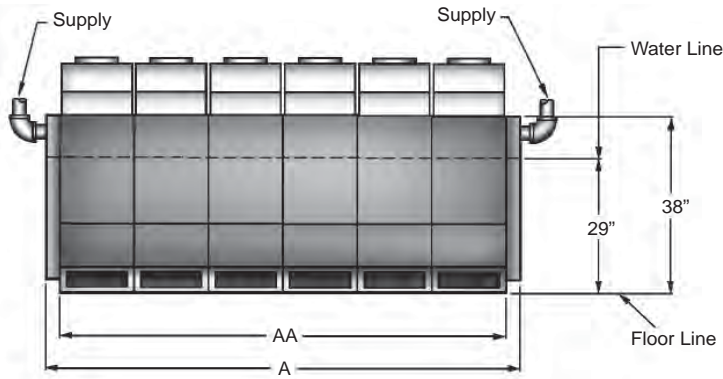

**Left Side View**

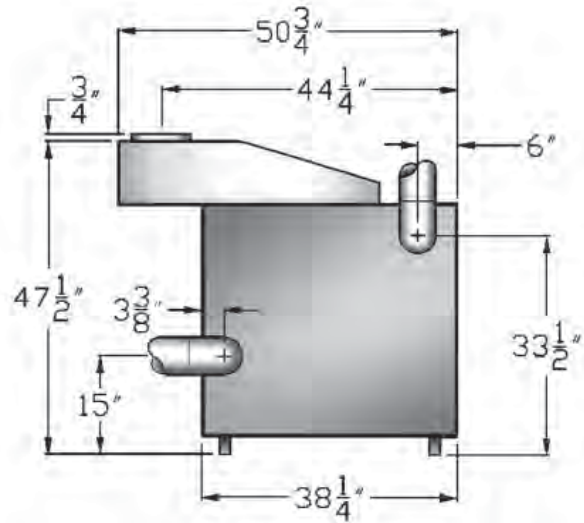

**Top View**

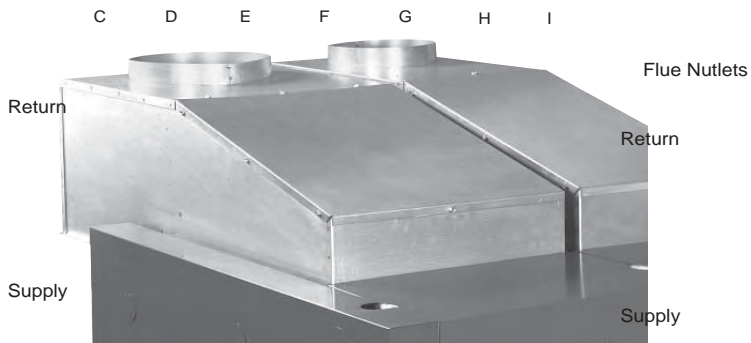

**ALL SUPPLY AND RETURN CONNECTIONS ARE 4 INCH**

**Chart 3**

Boiler Model No.	Water Content in Gallons		Shipping Weight Lbs.	A Jacket Width L to R	AA Base & Battery Length	C	D	E	F	G	H	I
	Steam	Water										
300	20	26	922	18 3/4	16 3/4	9 3/8	-	-	-	-	-	9 3/8
400	25	33	1133	23	21	11 1/2	-	-	-	-	-	11 1/2
500	30	40	1344	27 1/4	25 1/4	13 5/8	-	-	-	-	-	13 5/8
600	35	46	1555	31 1/2	29 1/2	9 3/8	12 3/4	-	-	-	-	9 3/8
700	40	52	1766	35 3/4	34 3/4	9 3/8	14 7/8	-	-	-	-	11 1/2
800	45	58	1977	40	38	11 1/2	17	-	-	-	-	11 1/2
900	50	65	2188	44 1/4	42 1/4	11 1/2	19 1/8	-	-	-	-	13 5/8
1000	55	71	2399	48	46 1/2	13 5/8	21 1/4	-	-	-	-	13 5/8
1100	60	78	2610	52 3/4	50 3/4	9 3/8	14 7/8	17	-	-	-	11 1/2
1200	65	84	2821	57	55	11 1/2	17	17	-	-	-	11 1/2
1300	70	91	3032	61 1/4	59 1/4	9 3/8	17	21 1/4	-	-	-	13 5/8
1400	75	97	3243	65 1/2	63 1/2	11 1/2	19 1/8	21 1/4	-	-	-	13 5/8
1500	80	104	3454	69 3/4	67 3/4	13 5/8	21 1/4	21 1/4	-	-	-	13 5/8
1600	85	110	3665	74	72	11 1/2	17	17	17	-	-	11 1/2
1700	90	117	3876	78 1/4	76 1/4	9 3/8	14 7/8	19 1/8	21 1/4	-	-	13 5/8
1800	95	123	4087	82 1/2	80 1/2	11 1/2	17	19 1/8	21 1/4	-	-	13 5/8
1900	100	130	4298	86 3/4	84 3/4	11 1/2	19 1/8	21 1/4	21 1/4	-	-	13 5/8
2000	105	136	4509	91	89	13 5/8	21 1/4	21 1/4	21 1/4	-	-	13 5/8
2100	110	143	4720	95 1/4	93 1/4	9 3/8	12 3/4	17	21 1/4	21 1/4	-	13 5/8
2200	115	149	4931	99 1/2	97 1/2	11 1/2	17	17	19 1/8	21 1/4	-	13 5/8
2300	120	156	5142	103 3/4	101 3/4	11 1/2	17	19 1/8	21 1/4	21 1/4	-	13 5/8
2400	125	162	5353	108	106	11 1/2	19 1/8	21 1/4	21 1/4	21 1/4	-	13 5/8
2500	130	169	5564	112 1/4	110 1/4	13 5/8	21 1/4	21 1/4	21 1/4	21 1/4	-	13 5/8
2600	135	175	5775	116 1/2	114 1/2	9 3/8	12 3/4	17	21 1/4	21 1/4	21 1/4	13 5/8
2700	140	182	5986	120 3/4	118 3/4	9 3/8	14 7/8	19 1/8	21 1/4	21 1/4	21 1/4	13 5/8
2800	145	188	6197	125	123	11 1/2	17	19 1/8	21 1/4	21 1/4	21 1/4	13 5/8
2900	150	195	6408	129 1/4	127 1/4	11 1/2	19 1/8	21 1/4	21 1/4	21 1/4	21 1/4	13 5/8
3000	155	201	6619	133 1/2	131 1/2	13 5/8	21 1/4	21 1/4	21 1/4	21 1/4	21 1/4	13 5/8

**Base Assembly**

The 300, 400 and 500 boilers are the basic models. The 300 model has (6) burners, the 400 model has (8) burners and the 500 model has (10) burners. Combinations of the basic models are used to assemble the 600 through 3000 models. Refer to **Chart 3** for the proper order of assembly. When two or more bases are used to assemble the boiler, be sure the tops of the bases are even.

The bases are fastened together with 5/16 cap bolts and nuts. Insert two bolts in the front posts and two in the rear posts as shown in **Figure 7A** . After bases are fastened together, install the base end panels. These end panels must be installed before assembling sections **Figure 7B**.

**Important:** After bases are assembled check to be sure they are level.

**Figure 7A**

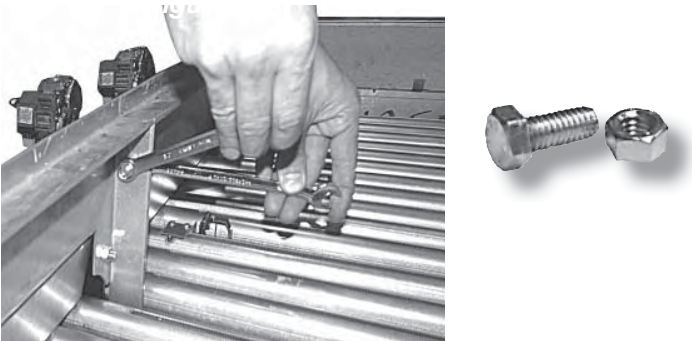

**Figure 7B**

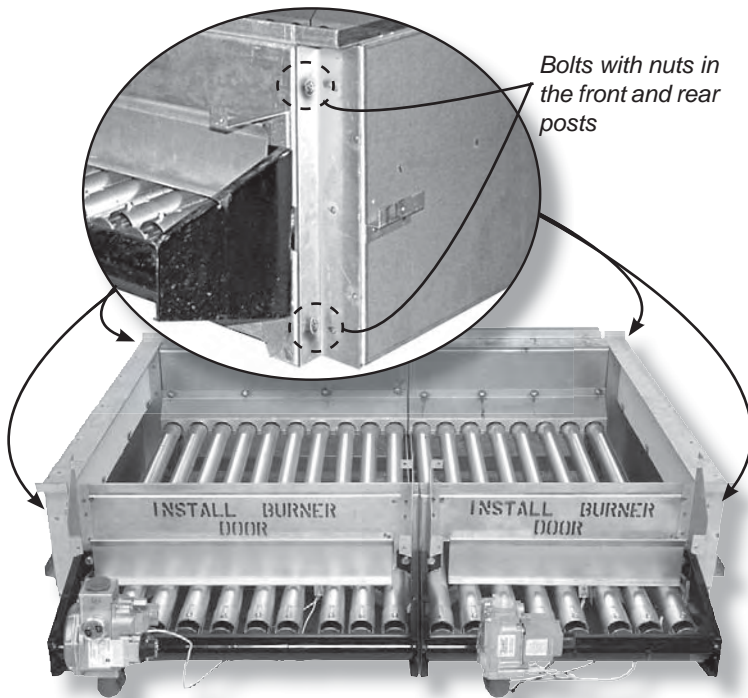

**Section Assembly**

The sections may be started from either the left or right end of the base.

Place the end section on the base with the center-line of the section directly over the joint of the base end closure. With boilers having two or more bases, as you progress be sure the parting line (center-line of section) of the intermediate sections fall on the junction of the two bases. **Figure 8**.

**Figure 8**

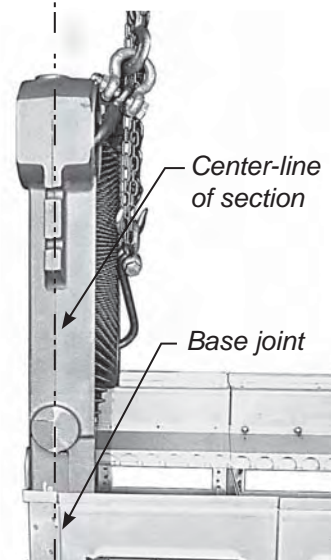

Before beginning, clean nipples and nipple ports. Coat nipples and nipple ports with pipe joint compound or other good sealant and keep them clean. **Figure 9**.

**Figure 9**



**Figure 10**

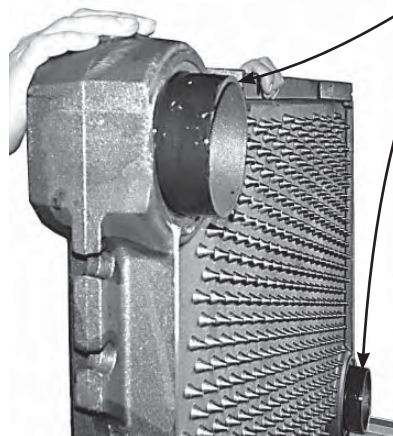

Place nipples in ports taking care to seat them squarely to prevent cocking. **Figure 10.**

When pulling sections together with tie rods, always insert tie rods in holes nearest to nipple ports. Move tie rods to proper location, if necessary, only after sections are fully pulled together. Oil or lubricate threads, insert tie rods in lugs with washers under nuts and tighten uniformly and evenly so that sections are pulled parallel as they go together. When all sections are pulled up locate tie rods in alternating pairs of upper and lower holes between adjacent sections. **Figure 11.**

Be sure both ends of completed section assembly are resting evenly on both ends of base.

Apply furnace cement at the joints of the sections front, top and back. Putty should also be applied where the sections join the base. **Figure 12.**

Place necessary plugs and control wells in correct locations. Plug all other tappings, leaving air vent in top of one of end sections, and connect water. Fill boiler with water until it runs out the air vent. Hydrostatically test boiler in accordance with applicable codes. Check for leaks before continuing with assembly Drain and remove unnecessary plugs.

**Figure 11**

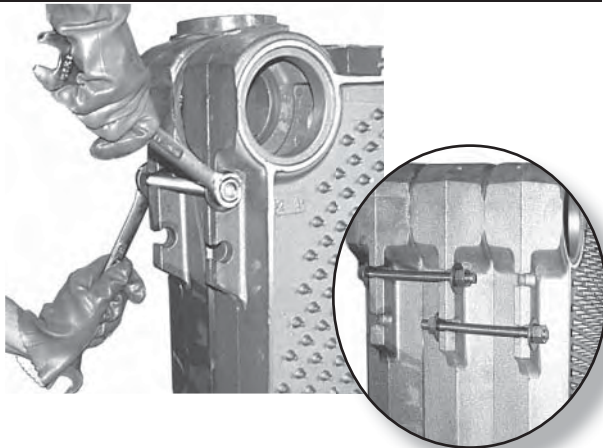

**Figure 12**

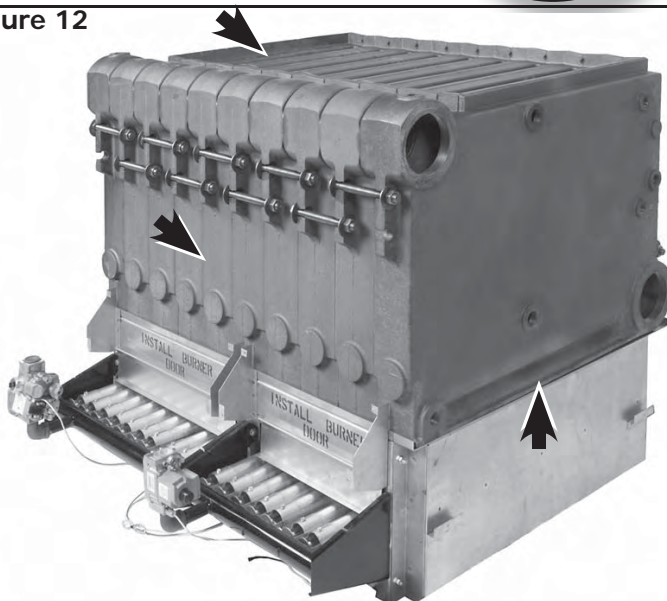

Apply furnace cement to joints on all sides of boiler.

**Attaching Draft Hoods**

Attach the draft hoods to the boiler sections after applying boiler putty to the top of the boiler sections where the hoods and sections meet. Use j-bolts to attach the fronts of the draft hoods to slots in the section flanges. **Figure 13.**

**Figure 13**

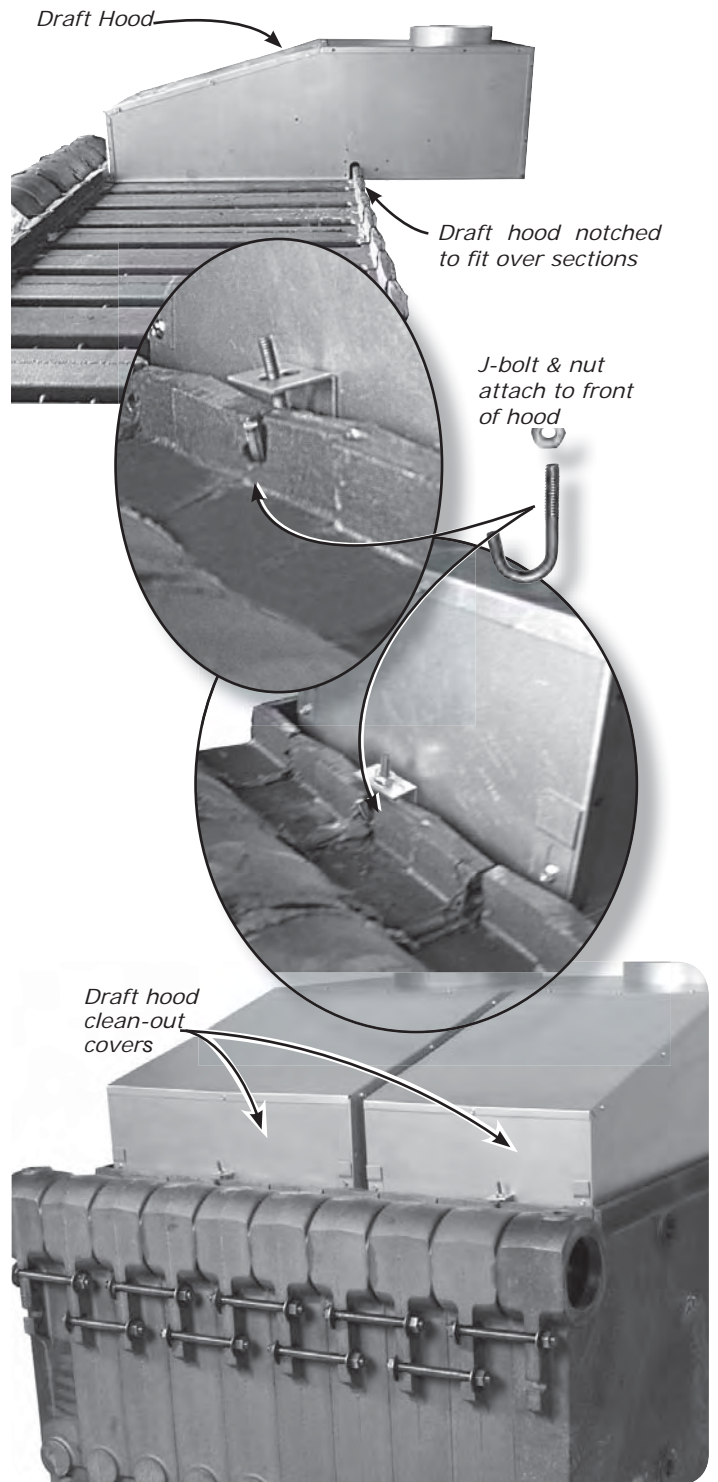

**Installing Boiler Jacket Panels**

**NOTE:** Jacket assembly must start at the left side of boiler.

1. Attach lower jacket end panel (left) to two Z-bars on base end closures through two slotted holes on bottom of jacket end panel. Use (2) #10 x 1/2" screws. **Figure 14.**
2. Attach middle jacket end panel (left) to lower jacket end panel with middle laying over lower and lining up holes. Use (5) #10 x 1/2" screws. **Figure 15.**
3. Attach upper jacket end panel (left) to middle jacket end panel with upper behind middle and lining up holes. Use (6) #10 x 1/2" screws. Attach upper jacket end panel to rear side of draft hood. Use (1) #8 x 3/4" screw. **Figure 16.**

4. Position top/front intermediate panel so back edge of top hangs on adjustable clips on front of draft hood(s); left edge hangs on bracket on left upper jacket end panel; and right edge with integral bracket hangs on tie rod(s). **Figure 17.**
5. Attach top/front intermediate panel to lower base brackets through four slotted holes in panel. Use (4) #10 x 1/2" screws. **Figure 18.**
6. On multiple base boilers, each additional top/front intermediate panel attaches in same way (working your way from left to right). **Figure 19.**

**Figure 14**



**Figure 15**

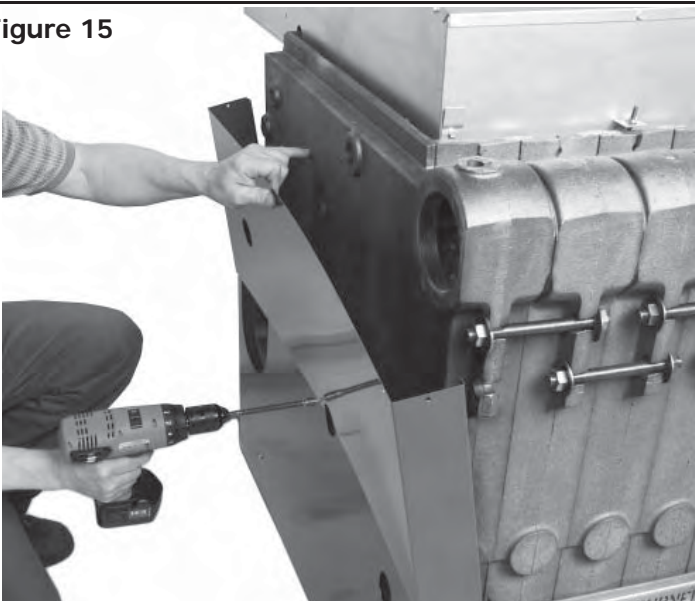

**Figure 16**

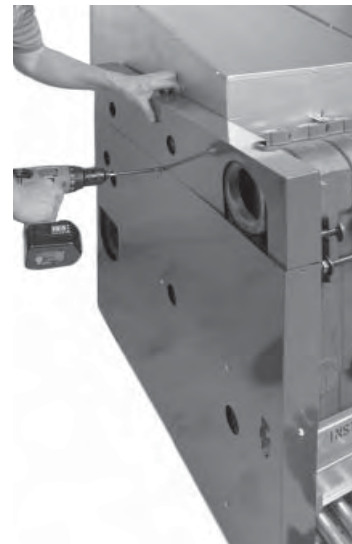

**Figure 17**

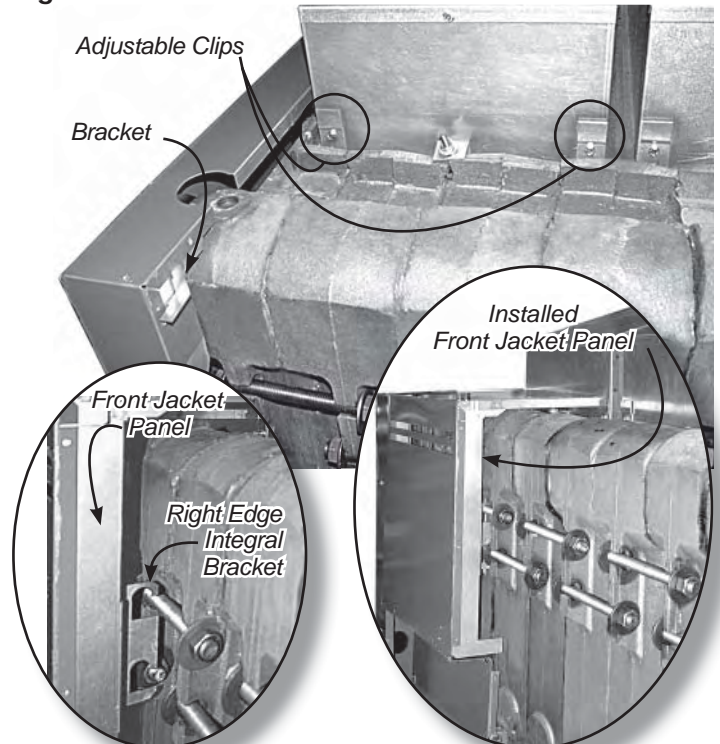

**Installing Boiler Jacket Panels - Continued**

7. Attach upper jacket end panel (right) so left edge hangs on bracket on top/front intermediate panel. Attach upper jacket end panel to rear side of draft hood. Use (1) #8 x 3/4" screw. **Figure 20.**
8. Attach middle jacket end panel (right) to upper jacket end panel with middle laying over upper and lining up holes. Use (6) #10 x 1/2" screws. **Figure 21.**

9. Attach lower jacket end panel (right) to middle jacket end panel with lower behind middle and lining up holes. Use (5) #10 x 1/2" screws. Attach lower jacket end panel to two Z-bars on base end closures through two slotted holes on bottom of jacket end panel. Use (2) #10 x 1/2" screws. **Figure 21B.**
10. Position top of rear jacket panel(s) to draft hood baffle flange and secure with (2) #10 x 1/2" screws. Secure bottom of rear jacket panel(s) to bracket(s) on boiler base using (2) #10 x 1/2" screws. **Figure 22.**

**Figure 18**

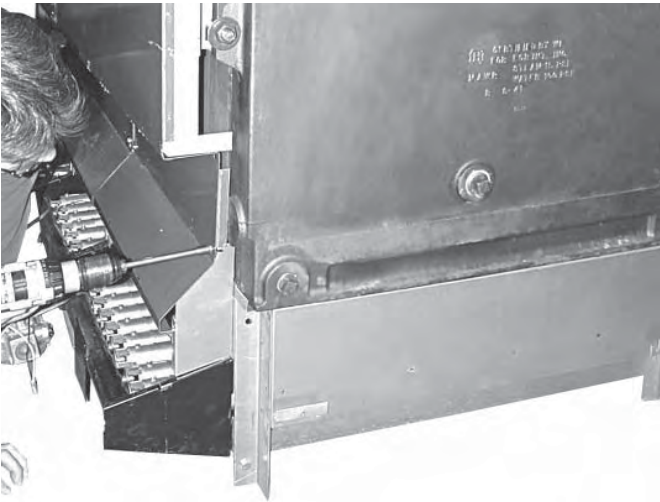

**Figure 20**

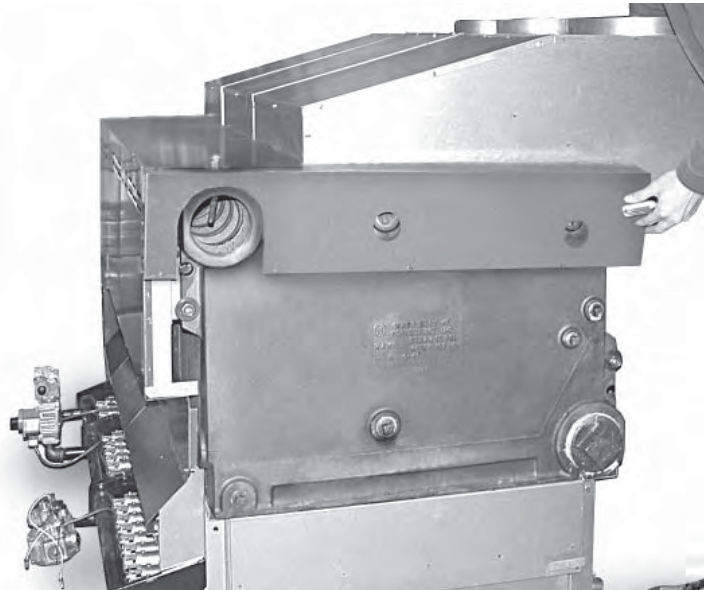

**Figure 19**

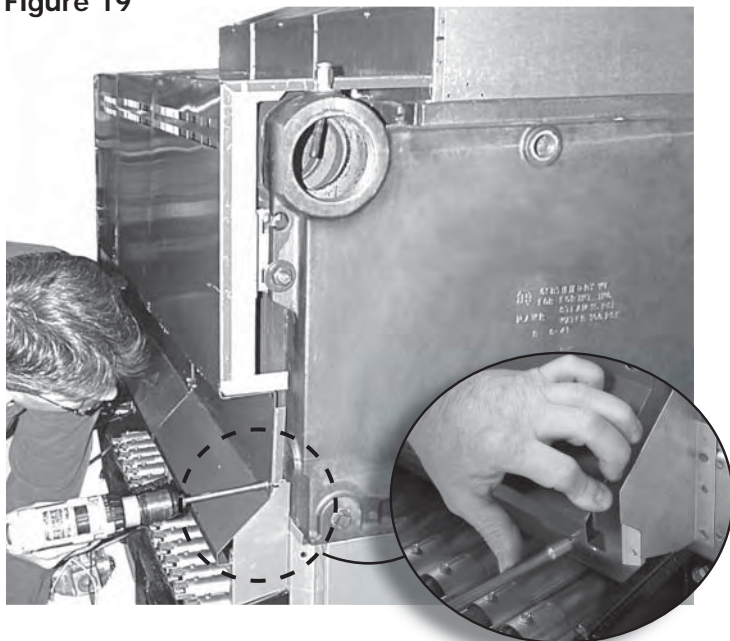

**Figure 21A**



**Installing Boiler Jacket Panels - Continued**

- 11.** Attach burner door knobs with #8-32 x ¼" screws and #8-32 hex nuts. Slide bottom of lower access door(s) in slots on top of manifold brackets. **Figure 23.**
- 12.** Position control access jacket panel(s) so tabs slide into slots on top/front intermediate jacket panel(s). Attach control access jacket panel to top/front intermediate jacket. Use (2) #10 x ½" screws. **Figure 24.**

- 13.** Lighting Instruction Plates are provided with each boiler base. Each boiler base also includes data plate indicating required gas type, firing rate, and gas pressure for that base. These plates are located on Jacket Top/Front Panels. Boilers also have rating plate showing total Input and Output Ratings. This rating plate is shipped in AC Carton and is to be mounted on side Jacket End Panel by installing contractor.
- 14.** Attach Local Code Label (*not provided by manufacturer.*)

**Figure 21B**



**Figure 22**



**Figure 23**

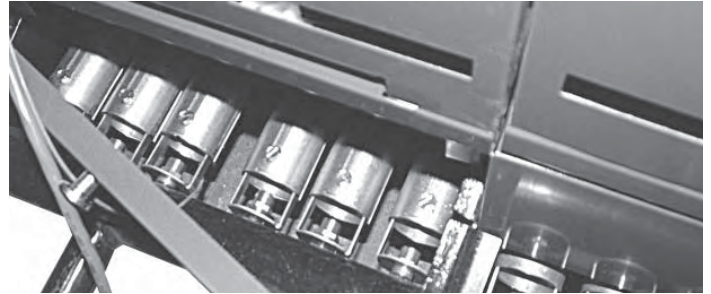

**Figure 24**

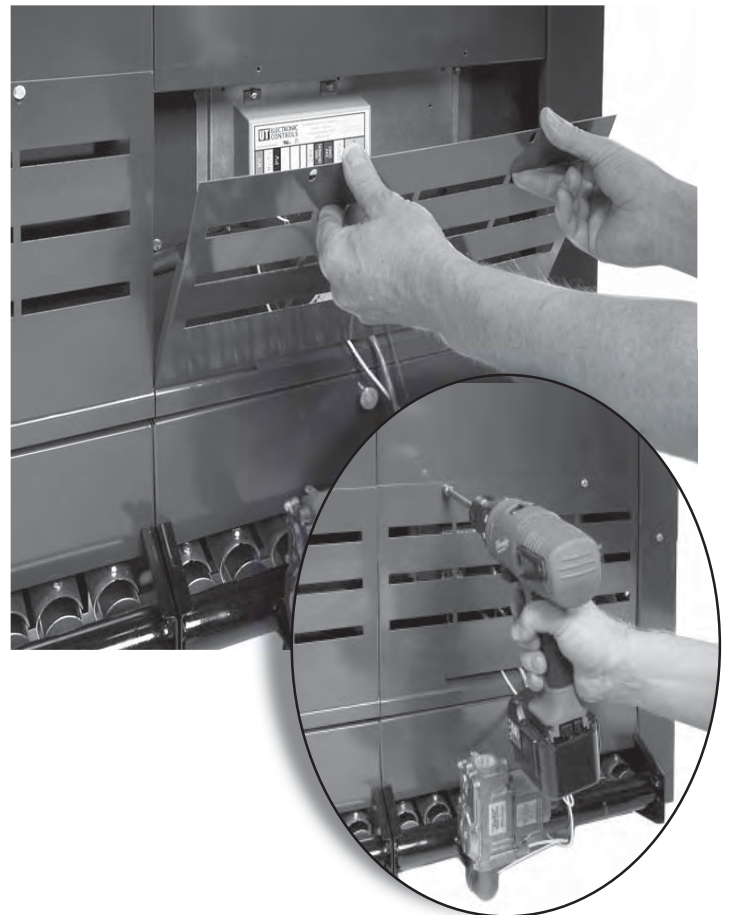

**NOTE:** The attachment of the control access jacket panels can wait until the controls have been mounted to the top/front intermediate jacket panels.



**Control Mounting And Installation**

**NOTE:** Electrical controls (j-box, transformer, etc. can be mounted on either left or right jacket end panel. Subsequently, boiler safeties (LWCO, etc.) and their respective piping must be mounted on opposite end of boiler.

1. Attach j-box assembly to jacket end panel aligning with holes in end panel. Use (4) #10 x 1/2" screws. **Figure 25A.**
2. Position harness and plug from j-box through opening in jacket end panel. **Figure 25B.**
3. Boilers with four through six bases, require transformer mounted externally to j-box assembly. Attach transformer and bracket assembly to jacket end panel by using #10 x 1/2" screws; (3) along top of bracket and (2) along lower edge of bracket. **Figure 26A.** Remove cover (2 screws) from J-box, then remove knockout (left or right side). Connect plug of harness from transformer to plug on j-box. **Figure 26B.**

4. Orient harness of control panel assembly so correct (female) plug is toward j-box and will connect to j-box harness. **Figure 27A.** Secure harness to control panel with zip-ties and #10 x 1/2" screws. **Figure 27A.** Connect plugs on harnesses. **Figure 27B.**
5. Attach control panel to intermediate jacket panel aligning with holes. Use (4) #10 x 1/2" screws. Connect plugs on control panel to j-box. **Figure 28.**
6. On multiple base boilers, mount remaining control panels to intermediate jacket panels following steps 4 & 5.
7. On each base, connect gas valve harness and pilot spark wire to control. **Figures 29A & 29B.**

**Figure 25A**

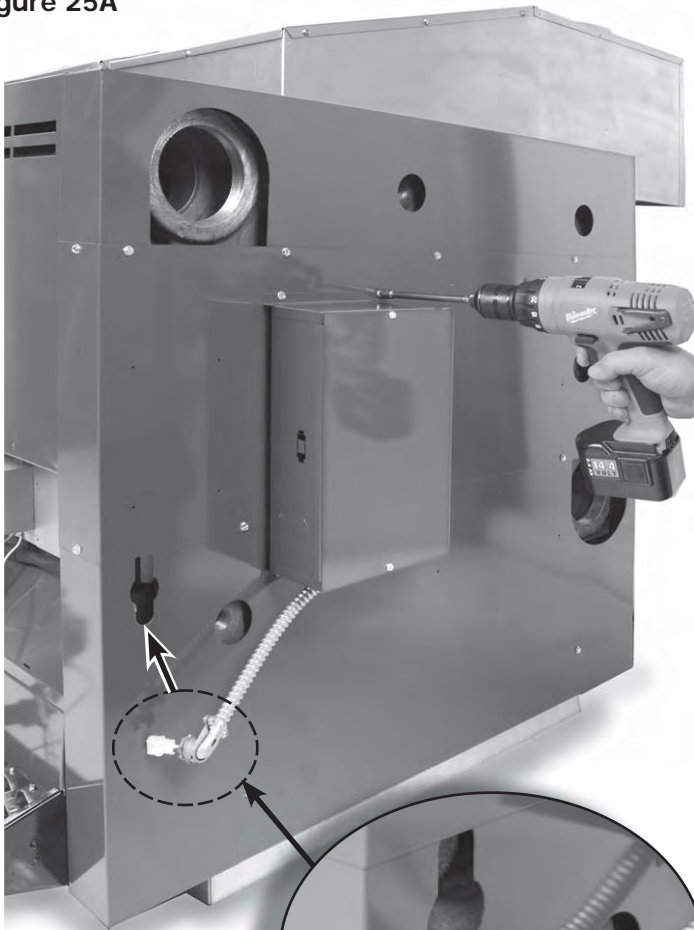

**Figure 25B**



**Figure 26A**

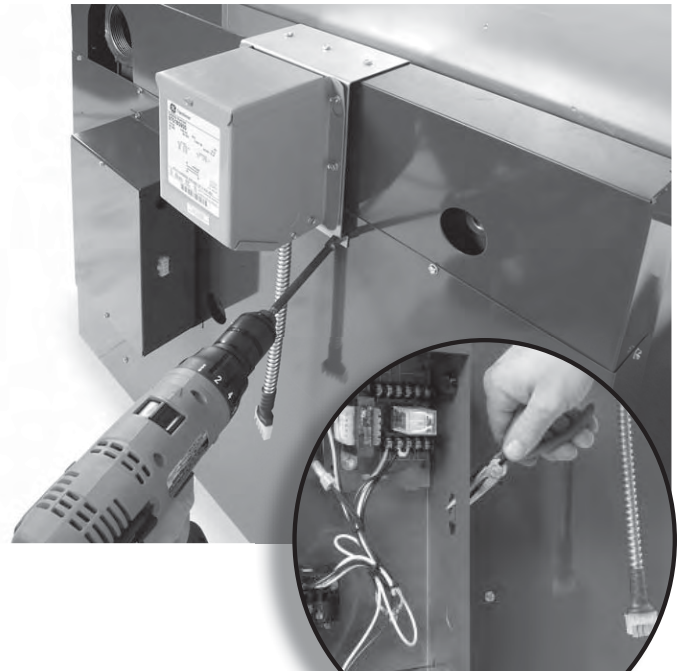

**Figure 26B**

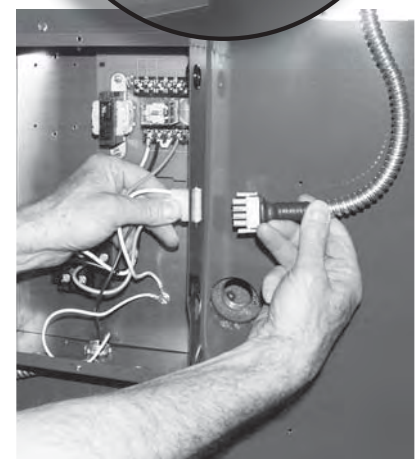

Control Mounting And Installation

Figure 27A

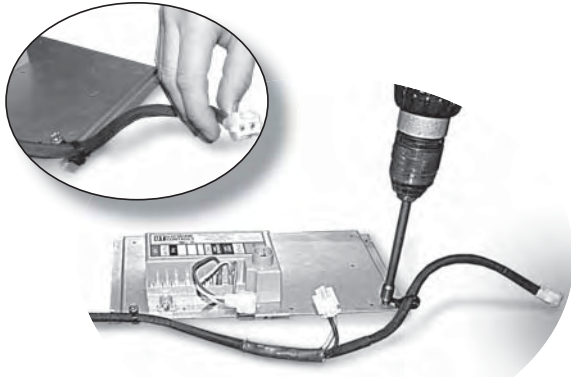

Figure 29A

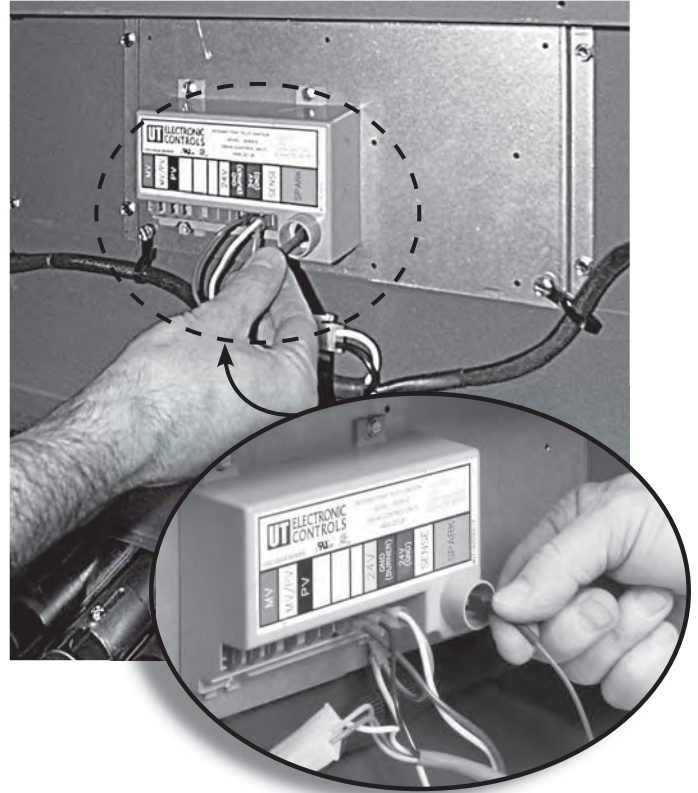

Figure 27B



Figure 29B

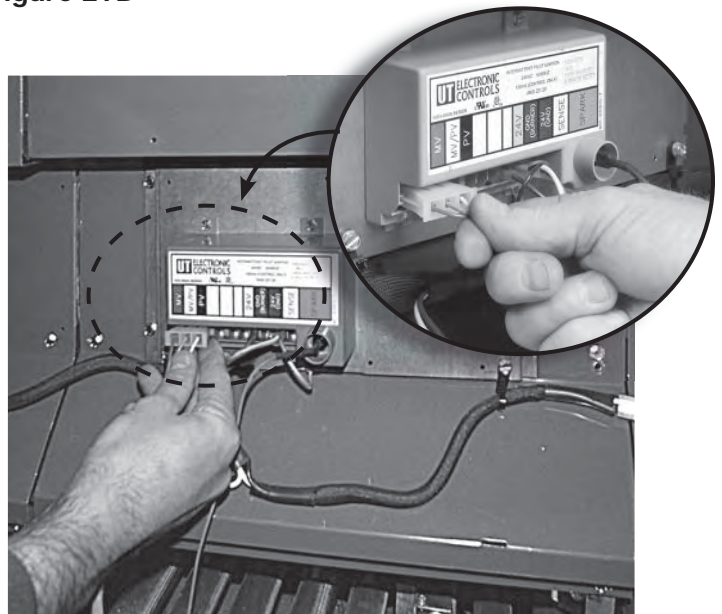
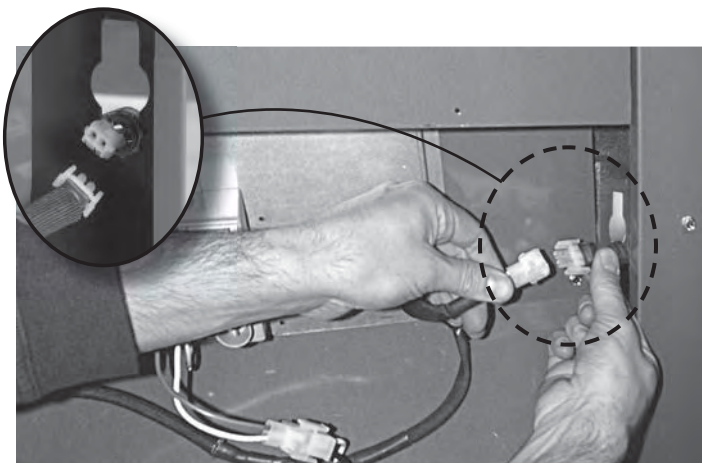

Figure 28



## TAPPINGS

Illustration shows the end section and the various tapplings provided. Tappings are the same in both right and left end sections.

OPENING	SIZE	STEAM	WATER
A	4"	Supply and Return	Supply and Return
B	½"	Primary LWCO and Gauge Glass Set	Plugged
C	¾"	Drain, Left End	Drain, Left End
C	¾"	Drain, Right End	Drain, Right End
D	½"	Plugged	Limit Control
E	1"	Accessories	Accessories
*F	1"	Safety Valve	Safety Relief Valve
G	¾"	Plugged or Electronic (Probe Type) LWCO	Plugged

\* If opening F is to be used for something other than the Safety Valve or Safety Relief Valve, or the Safety/Relief valve is larger than 1", the Safety/Relief Valve must be installed in the Header Piping as near the boiler as possible

### BOILER TRIM

Following controls are supplied as standard equipment. Details of their function and operation will be found in section on Controls and Adjustments.

### WATER TRIM

1. Water temperature high limit control
2. Combination temperature - pressure gauge
3. Safety relief valve (30 psi)

### WATER TRIM ASSEMBLY

Locate water trim controls per chart and illustration above.

### STEAM TRIM

1. Low Water Cut-Off (mounted externally) with blow-off valve
2. High Pressure Limit Control
3. Pressure Gauge
4. Water Gauge Glass Set
5. Siphon Loop
6. Safety Valve (15 psi.)

### STEAM TRIM ASSEMBLY

Assemble Steam Trim, Low Water Cut-Off, High Pressure Limit Control, Pressure Gauge, Water Gauge Glass Set and Siphon Loop, as shown in **Figures 30**. See Illustration and Chart above for location of controls.

Figure 29

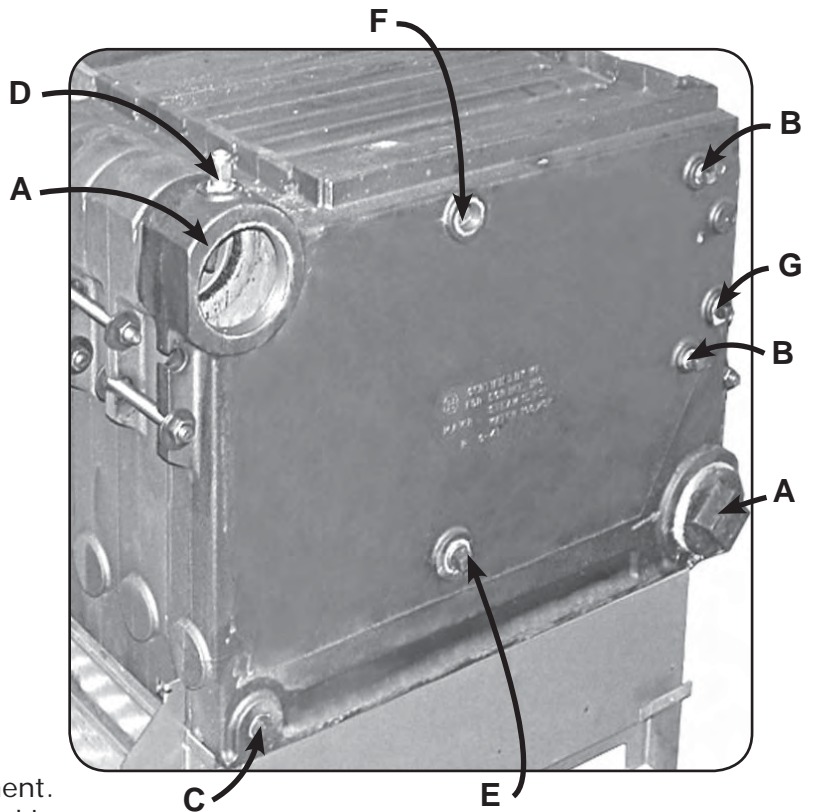
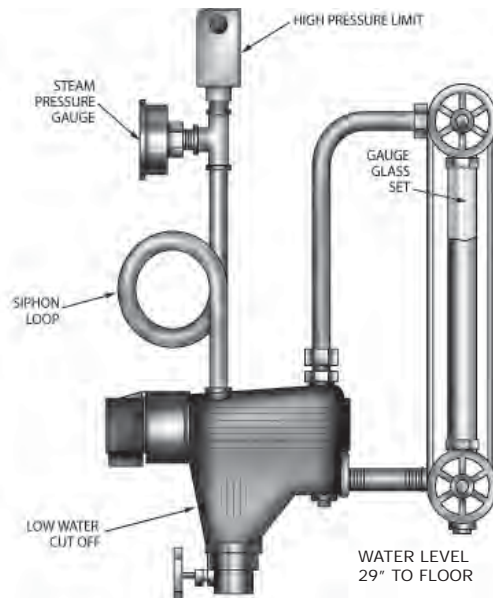

Figure 30



**NOTE:**

No shutoff of any description shall be placed between the pressure relief valve and the boiler, or on discharge pipes between such safety valves and the atmosphere. Installation of the pressure relief valve shall conform to the requirements of the ANSI/ASME Boiler and Pressure Vessel Code, Section IV.

**BOILERS USED WITH REFRIGERATION SYSTEM**

When the boiler is installed in connection with a refrigeration system, it must be piped so that the chilled medium is piped in parallel with the heating boiler with appropriate valves to prevent the chilled medium from entering the heating system. An example of such piping is shown in **Figure 31**, Valve A and B open for heating, closed for cooling. Valves C and D closed for heating, open for cooling.

When hot water boilers are connected to heating coils located in air handling units where they may be exposed to refrigerated air circulation on the boiler piping, the boiler piping system shall be equipped with flow control valves or other automatic means to prevent gravity circulation of the boiler water during the cooling cycle.

**WATER BOILER PIPING** Figure 32

Supply and return connections to the hot water boiler should be located so that the water will thoroughly circulate throughout the entire boiler. Each installation has a preferred piping arrangement according to the requirements of the particular system and choice of arrangements and sizes of headers should be decided upon by the installer's heating engineer or with standard engineering practice. When using only one supply and one return connection, return must be connected at opposite end of boiler from flow connection, on all boilers 600,000 Btu/hr input and larger.

**HIGH LIMIT**

The immersion well for the high limit control must be mounted at flow outlet of boiler. This may be either right or left hand. The temperature and pressure gages should be mounted at the outlet as well, and may be the opposite and of the high limit control.

**PIPE SIZING**

Piping connection sizes are important to control proper water velocity at the inlet and outlet connections to the water boiler. It is recommended that the following pipe sizes be used for flow rates shown and that the boiler being headered to tapplings at both ends, where one pipe connection will not be adequate to hold water velocities below 3.33 feet per second.

FLOW RATE GPM	PIPE SIZE
35 - 50	2½"
51 - 76	3"
77 - 131	4"
132 - 205	5"
206 - 300	6"

Figure 31

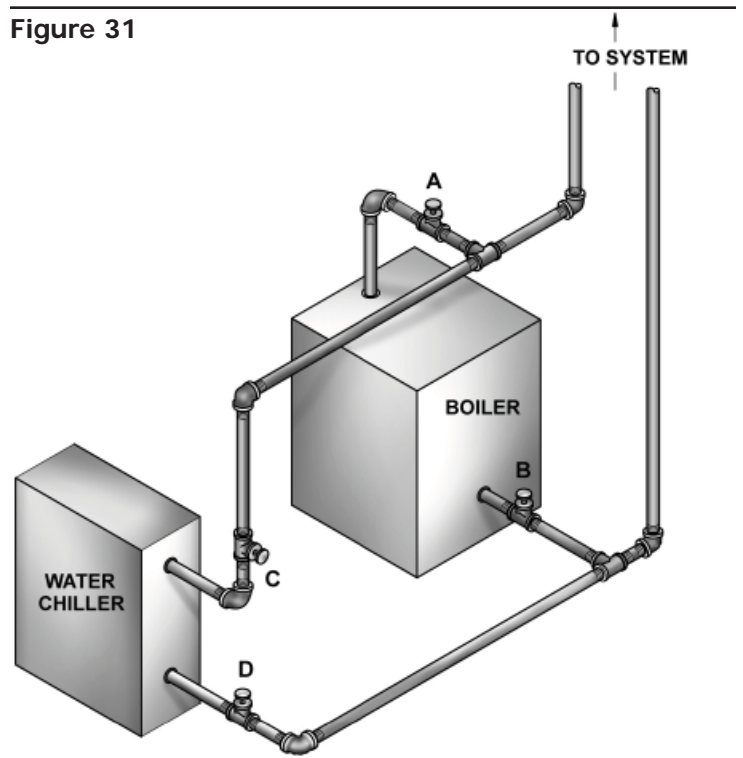

Figure 32

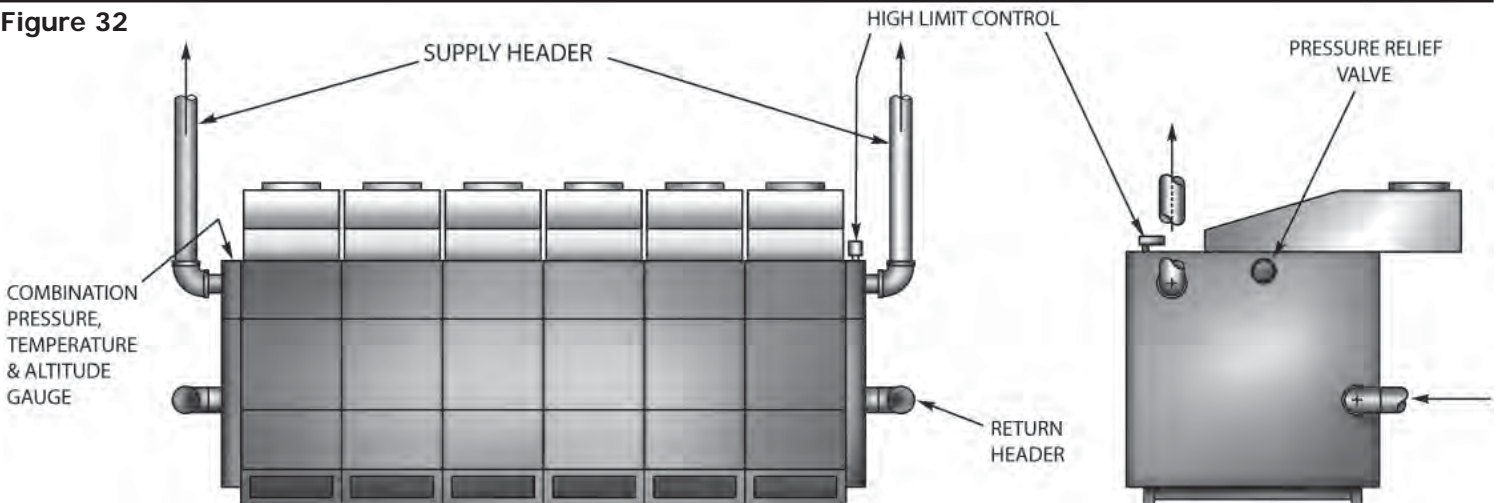
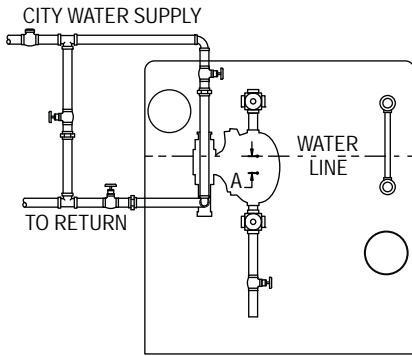

Figure 33

**STEAM BOILERS - SERIES S**  
**BOILER TAPPINGS ARE AVAILABLE FOR ALL CONNECTIONS SHOWN**

*NOTE: Mount electrical supply on opposite side.*



**McDONNELL FEEDER CUTOFF COMBINATION**

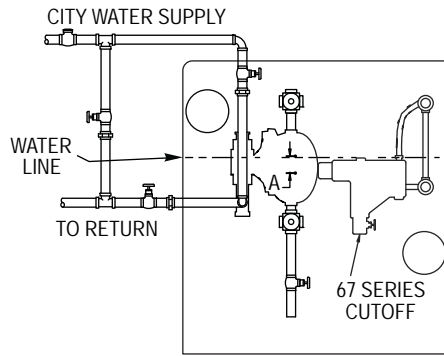

**SEPARATE McDonnell FEEDER AND SEPARATE McDonnell LOW-WATER CUTOFF**

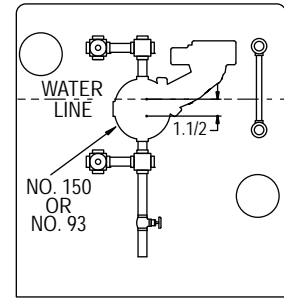

**McDONNELL PUMP CONTROL AND LOW-WATER CUTOFF USED WITH CONDENSATE RECEIVER AND ELECTRIC BOILER FEED PUMP**

BOILER SIZE	USE
300 THRU 1500	No. 47-2* Control Mounts in Gauge Glass Tappings
1600 THRU 3000	No. 51.2* Control Mounts in 1-inch Tappings

*NOTE: For multiple boiler installation with gravity return, use feeder Cutoff Combination or separate feeder and separate cutoff on each boiler.*

FOR CLOSED HEATING SYSTEMS  
 DIMENSION A = 2 • 2 1/2

BOILER SIZE	USE
300 THRU 1500	No. 247 mechanical feeder or No. 101-24V electric feeder with transformer - for use on closed heating systems only.
1600 THRU 3000	No. 51.2*

*NOTE: For multiple installation with condensate tank and single boiler feed pump, use No. 93 on each boiler to operate motorized valve in each boiler feed line.*

FOR CLOSED HEATING SYSTEMS  
 DIMENSION A - 2 = 2 1/2 inches

FOR PROCESS OR PARTIAL PROCESS SYSTEMS  
 DIMENSION A - 1 = 1 1/2 inches

\*These items available through your Distributor.

Figure 34

**WATER BOILERS - SERIES W**  
**BOILER TAPPINGS ARE AVAILABLE FOR ALL CONNECTIONS SHOWN WITH EXCEPTION OF NO. 764 WHICH MOUNTS IN PIPING**

*NOTE: Mount electrical supply on opposite side.*

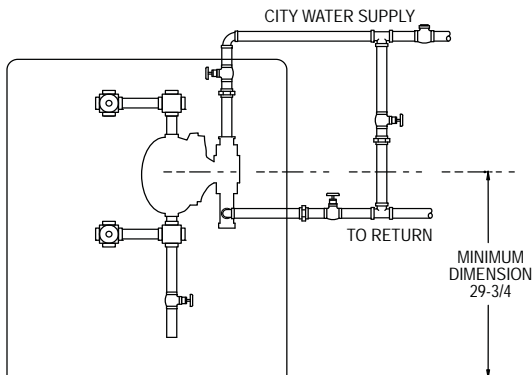

**McDONNELL FEEDER CUT-OFF COMBINATION**

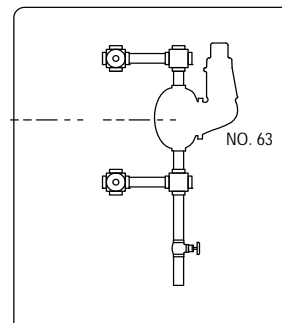

**McDONNELL LOW-WATER CUT-OFF**

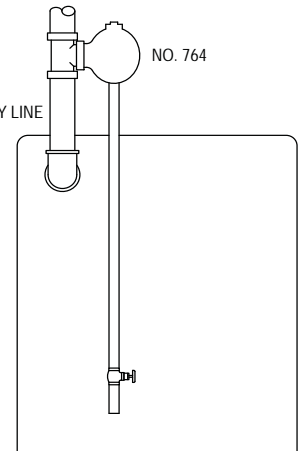

For boilers with up to 75-psi relief valve setting\*\*

BOILER SIZE	USE
ALL SIZES	No. 53-2

For boilers with 30-psi relief valve setting

BOILER SIZE	USE
300 THRU 1500	No. 247-2
1600 THRU 3000	No. 51-2*

For boilers with 75-to 100-psi relief valve setting

BOILER SIZE	USE
ALL SIZES	No. 150

\*These items available through your Distributor.  
 \*\* Water supply pressure must exceed relief valve setting by at least 20 psi.

For all boilers up to 50-psi relief valve setting

BOILER SIZE	USE
ALL SIZES	No. 63*
ALL SIZES	NO. 764*

Figure 35

**STEAM BOILER PIPING**

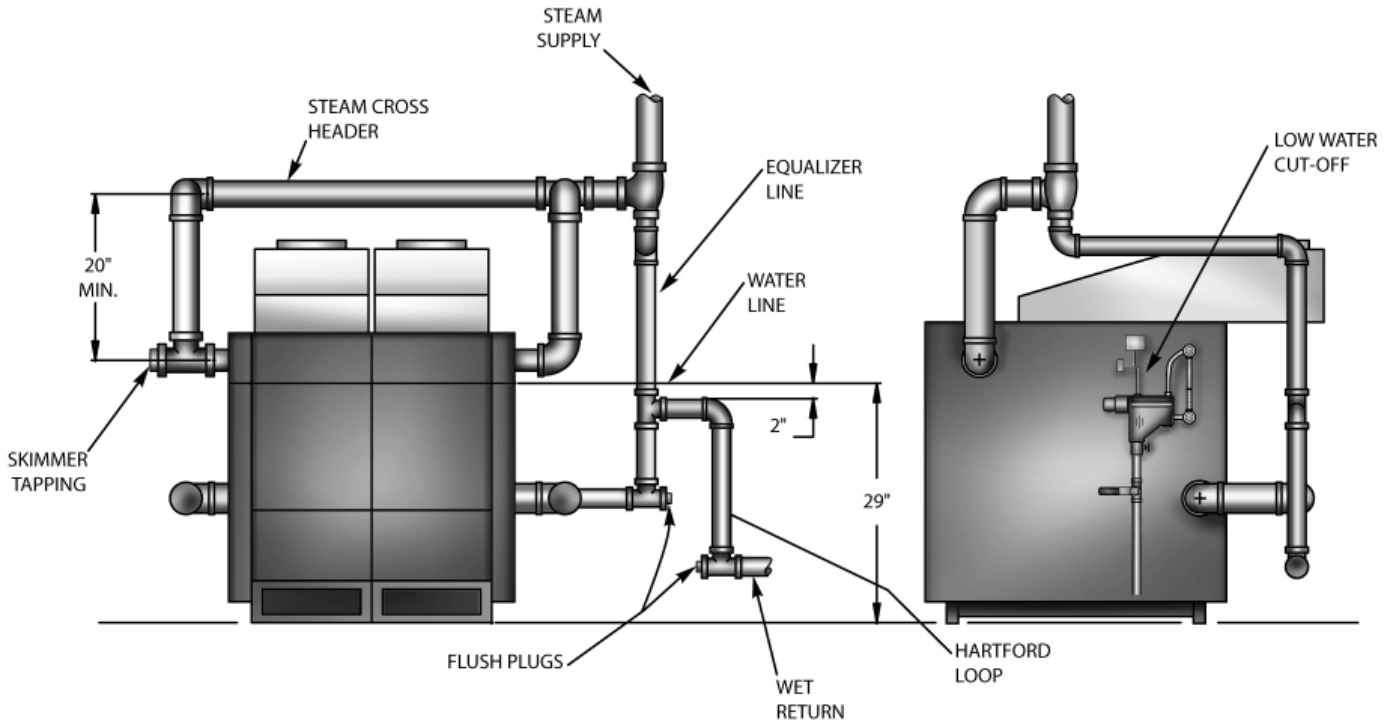

**SAFETY VALVE SHOULD BE FIELD INSTALLED AS CLOSE AS POSSIBLE TO BOILER**

***STEAM BOILER PIPING* Figure 35**

Full size steam header is recommended on all steam systems as shown above. On Boiler Models 300, 400 and 500 full header may be eliminated and single steam header taken off either side of boiler provided system is clean and properly designed.

Risers should be full 4" and at least 20" in height. Use skimmer tee as shown.

Area of Main Steam Cross Header Pipe should be equal to or larger than total area of Steam Supply Mains leading from Header and should never be smaller than Supply Tappings on Boiler. Return Header should be piped to both ends of Boiler. Area of Return Header should be equal to total area of Return Mains or larger.

Steam cross headers must be piped with swing joints, or be equipped with slip joint connector, in order to prevent expansion and contraction of steam header from damaging boiler.

Each installation has preferred piping arrangement according to requirements of particular system and choice of arrangements and sizes of Headers should be decided upon by installer's heating engineer or with standard engineering practice.

**⚠ WARNING**

Do not install shut-off or steam valve between safety valve and boiler.

Steam Piping Size			
Model	Header	Riser	Equalizer
300 to 900	4"	4"	2"
1000 to 1900	4"	4"	2 ½"
2000 to 2500	4"	4"	3"
2600 to 3000	4"	4"	4"

## CONNECTING GAS SERVICE

- Connect gas service from meter to control assembly(s) in accordance with ANSI Z223.1 and local codes or utility. On multiple base boilers, connect gas service with branch lines from common main. Individual branch lines must be same size as inlet to gas valve. Ground joint union should be installed in each branch line for easy servicing of gas controls. Drip leg or trap should be installed at bottom of vertical section of piping at inlet to each branch line. **Figure 36**. Pipe compound resistant to action of liquefied petroleum gases must be used on all threaded pipe connections.
- Main gas supply line should be adequate to prevent undue pressure drop. See **Chart 5** for pipe sizes for gas mains.
- Boiler and its gas connection must be leak tested before placing boiler in operation.
  - Boiler and its individual shutoff valve must be disconnected from gas supply piping system during any pressure testing of that system at test pressures in excess of 1/2psi (3.5kPa).
  - Boiler must be isolated from gas supply piping system by closing its individual manual shutoff valve during any pressure testing of gas supply piping system at test pressures equal to or less than 1/2 psig (3.5 kPa)

Chart 4						
Minimum Gas Supply Pressure						
Models	5.0 inches w.c.					
		300	500	600	1000	1300
	2000	2100	2500	2600	3000	
Models	5.3 inches w.c.					
	400	700	800	900	1100	1200
	1400	1600	1700	1800	1900	2200
	2300	2400	2700	2800	2900	
All Models	Maximum Gas Supply Pressure					
	13.5 inches w.c.					
All Models	Manifold Pressure					
	3.5 inches w.c.					

Chart 5									
TABLE OF PIPE SIZES IN INCHES FOR GAS MAINS (NATURAL GAS)									
Boiler No	20'	30'	40'	50'	60'	80'	100'	125'	150'
300	1¼	1¼	1¼	1¼	1¼	1¼	1½	1½	1½
400	1¼	1¼	1¼	1¼	1½	1½	1½	1½	2
500	1¼	1¼	1¼	1½	1½	1½	2	2	2
600	1¼	1½	1½	1½	2	2	2	2	2
700	1¼	1½	1½	2	2	2	2	2	2½
800	1½	1½	2	2	2	2	2	2½	2½
900	1½	2	2	2	2	2	2½	2½	2½
1000	1½	2	2	2	2	2½	2½	2½	2½
1100	2	2	2	2	2	2½	2½	2½	2½
1200	2	2	2	2	2½	2½	2½	2½	3
1300	2	2	2	2½	2½	2½	2½	3	3
1400	2	2	2	2½	2½	2½	3	3	3
1500	2	2	2½	2½	2½	2½	3	3	3
1600	2	2	2½	2½	2½	2½	3	3	3
1700	2	2½	2½	2½	2½	3	3	3	3
1800	2	2½	2½	2½	2½	3	3	3	3
1900	2	2½	2½	2½	3	3	3	3	3
2000	2	2½	2½	2½	3	3	3	3	3
2100	2½	2½	2½	3	3	3	3	3	4
2200	2½	2½	2½	3	3	3	3	4	4
2300	2½	2½	3	3	3	3	3	4	4
2400	2½	2½	3	3	3	3	3	4	4
2500	2½	3	3	3	3	3	4	4	4
2600	3	3	3	3	3	4	4	4	4
2700	3	3	3	3	4	4	4	4	4
2800	3	3	3	4	4	4	4	4	4
2900	3	3	4	4	4	4	4	4	4
3000	3	4	4	4	4	4	4	4	4

**Figure 36**

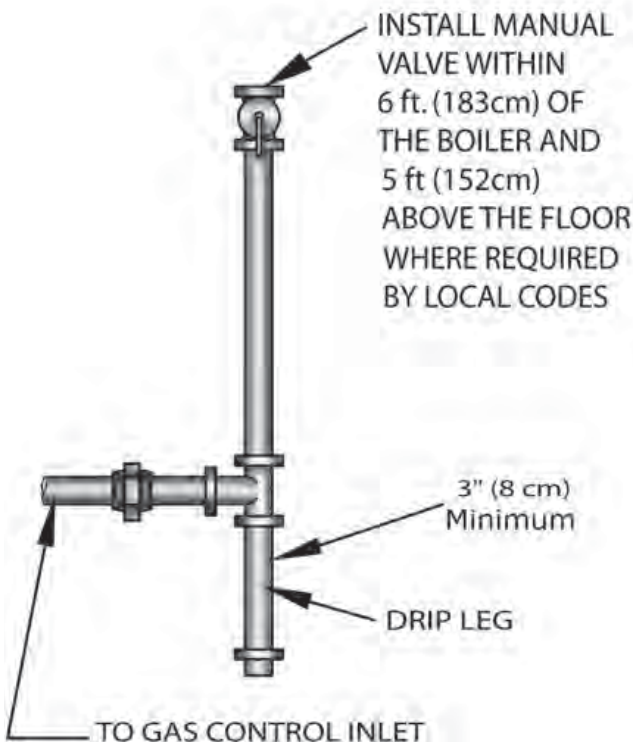

**⚠️ WARNING**

Electrical shock hazard. Turn OFF electrical power supply at service panel before making any line voltage connections. Failure to do so could result in death or serious injury.

**⚠️ CAUTION**

Label all wires prior to disconnection when servicing controls. Wiring errors can cause improper and dangerous operation.

**Electrical Wiring**

The boiler, when installed, must be wired and electrically bonded to ground in accordance with the requirements of the authority having jurisdiction or, in the absence of such requirements, with the National Electrical Code, ANSI/NFPA 70.

Install a fused disconnect switch between boiler and electrical panel in a convenient location. The wiring from high temperature limit control should be secured to the boiler jacket or gas piping to prevent an accidental disconnect from controls.

All wiring to gas valves must be taped securely to the gas supply lines or run in an appropriate conduit.

**Thermostat Installation**

The thermostat location has an important effect on the operation of the boiler system. Be sure to follow the instructions included with the thermostat. Locate the thermostat about 5 feet above the floor on an inside wall. It should be sensing average temperature.

Keep thermostat(s) at desired room temperature. If windows are to be opened or heat is not needed, set thermostat(s) pointer to a lower setting.

**Adjust Thermostat Heat Anticipator**

Suggested heat anticipator setting is .90 amps (set accordingly). Then follow instructions packaged with thermostat for final adjustment, **checking thermostat operation**. When set above temperature indicated on thermometer, boiler burners should ignite. Make certain thermostat(s) turns off boiler when room temperature reaches selected setting and starts boiler operating when room temperature falls few degrees.

Finally, set thermostat for desired temperature. Special conditions in building and location of thermostat will govern this setting.

**Stage Firing Multiple Base Boilers**

Multiple base hot water boilers are ideal for stage firing. Many controls are available for sequencing or stage firing multiple base hot water boilers. We offer Argo AMB Outdoor Reset Stage Fire Control Packages that will sequence up to eight bases, with lead boiler rotation, adjustable reset ratio, set point boiler rotation, and microprocessor control. This control will fire bases as required to maintain supply water temperature at a desired set point, which is automatically varied based on outdoor air temperature. Consult boiler manufacturer for more information.

**PLACES TO AVOID LOCATING THERMOSTAT**

<b>Dead Spots</b>	Behind Doors
	Corners and Alcoves
<b>Hot Spots</b>	Concealed Pipes
	Fireplaces
	TV Sets
	Lamps
	Direct Sunlight
	Kitchens
<b>Cold Spots</b>	Concealed Pipes or Ducts
	Stairwells
	Drafts
	Unheated Rooms on other side of Wall



Commercial Boiler, 1, 2 & 3 Base

COMMERCIAL BOILER, 1, 2 & 3 BASE

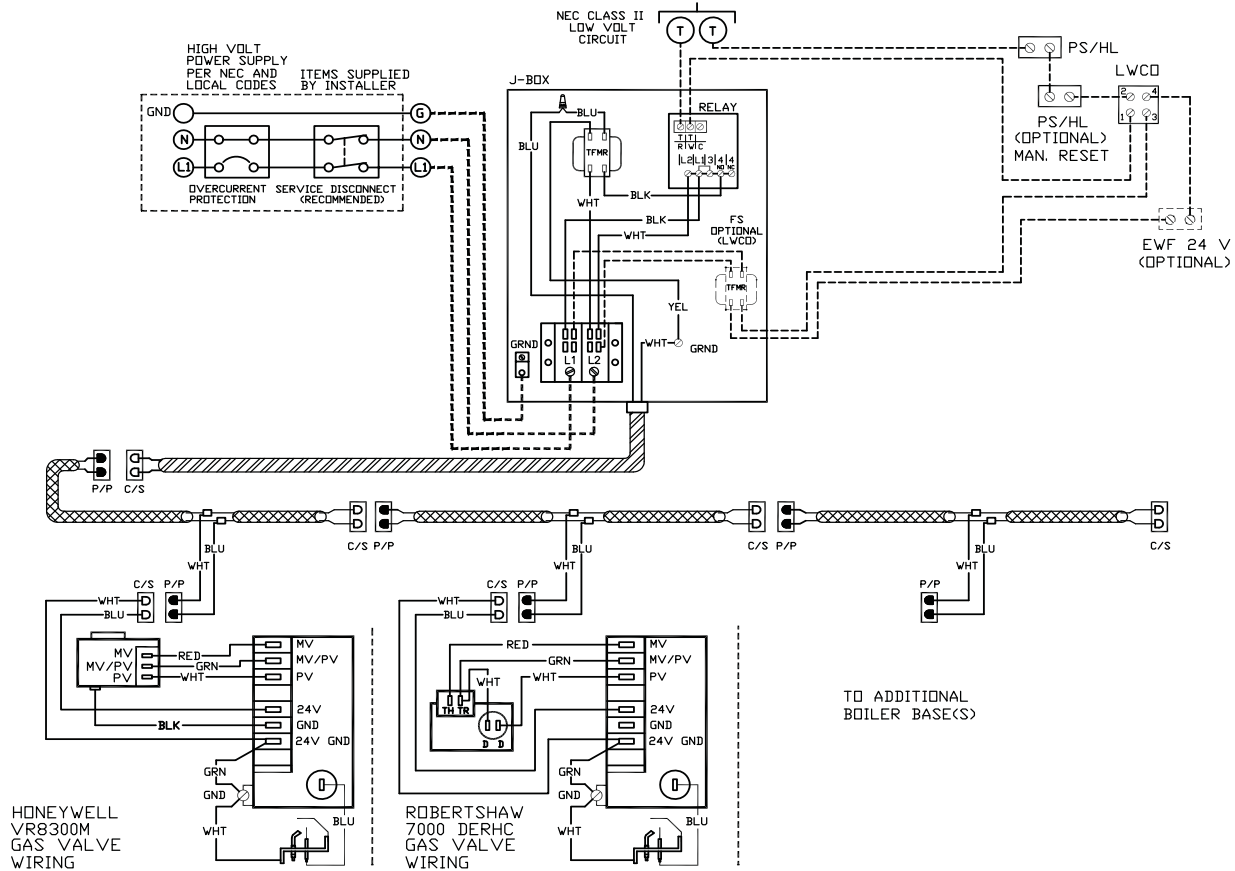

WIRING SCHEMATIC

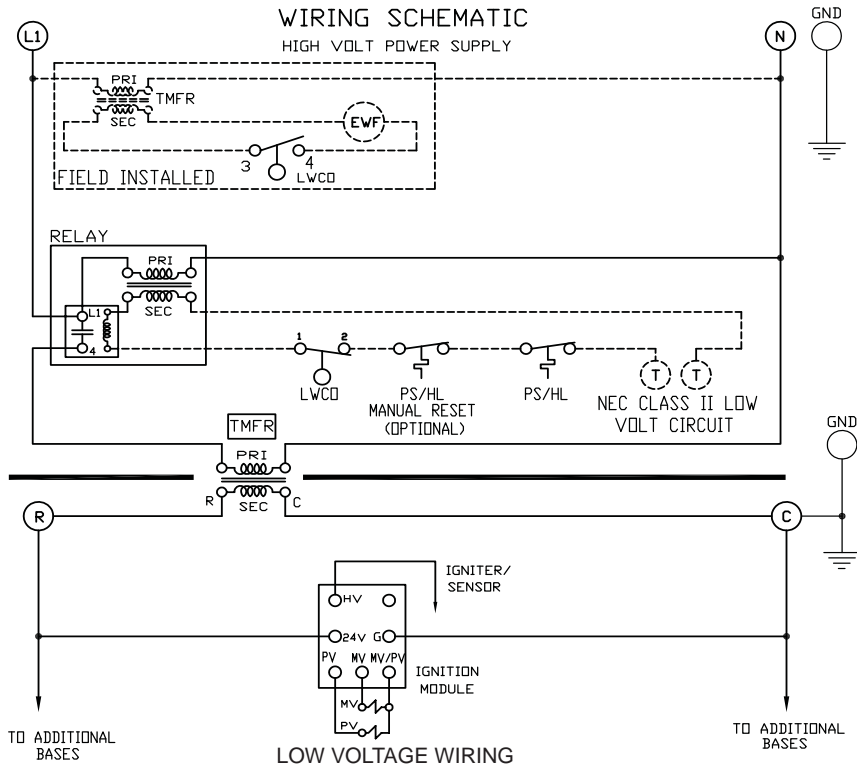

LEGEND

- LWCD = LOW WATER CUT OFF
- FS = FIELD SUPPLIED
- HL = HIGH LIMIT
- MV = MAIN VALVE
- PV = PILOT VALVE
- PSS = PILOT SAFETY SHUTOFF
- WTS = WATER TEMPERATURE SENSOR
- EWF = ELECTRIC WATER FEEDER
- P/P = PLUG/PIN
- C/S = CAP/SOCKET

- HIGH VOLT FIELD INSTALLED
- LOW VOLT FIELD INSTALLED

Commercial Boiler, 4, 5 & 6 Base

COMMERCIAL BOILER, 4, 5 & 6 BASE

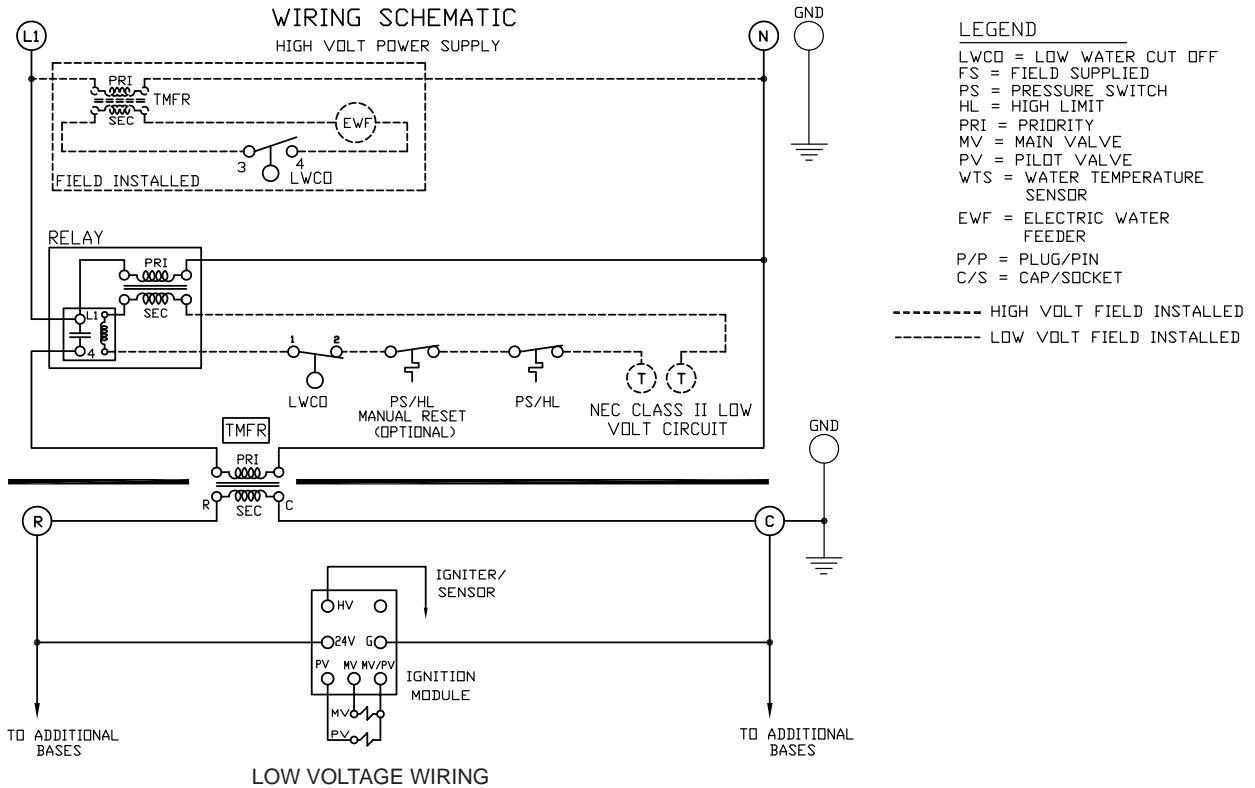
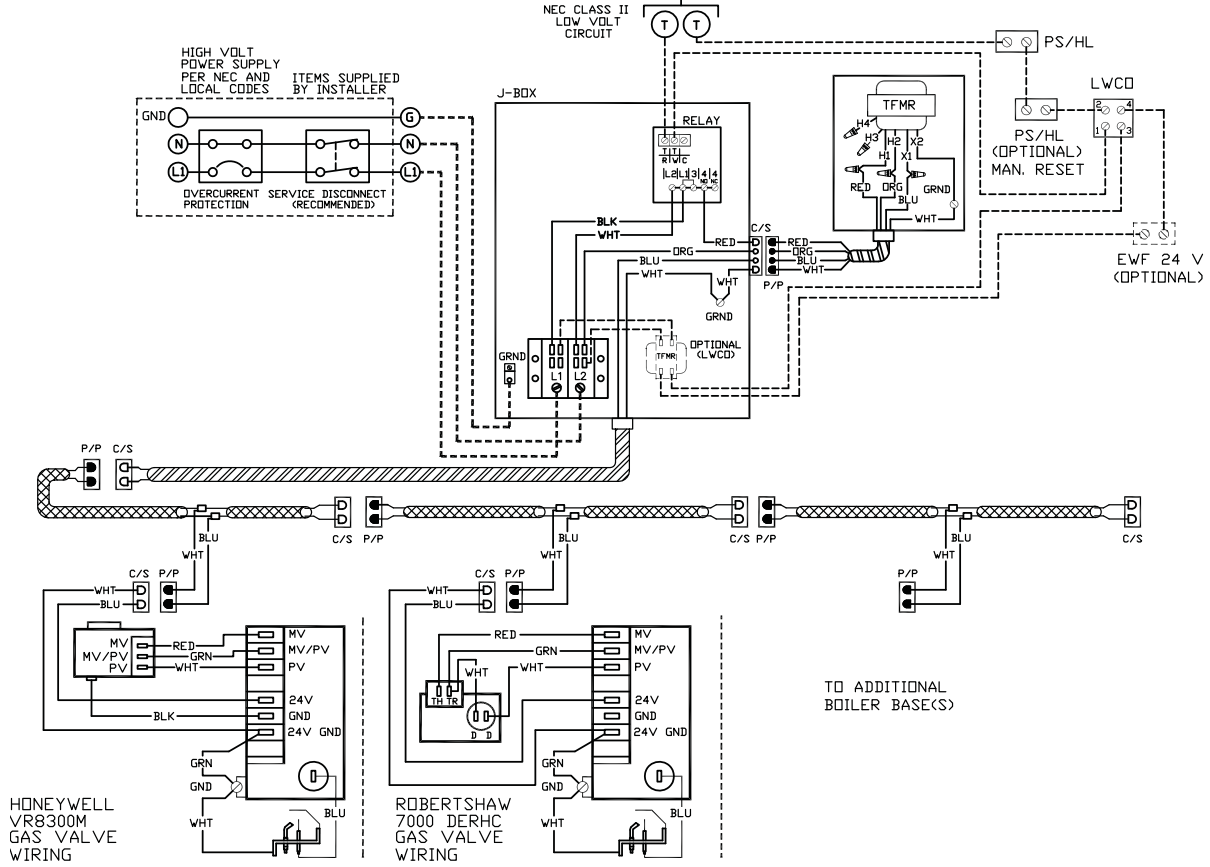

### Control Functions And Operation

The control module performs the following basic functions:

1. Opens and closes the first (pilot) operator of the gas valve.
2. Provides a spark for igniting pilot burner.
3. Senses the pilot burner flame.
4. Shuts off the spark after pilot flame is lit.
5. Opens and closes the second (main) operator.

These functions occur in two stages - trial for pilot ignition and main burner operation as described below.

#### Trial For Pilot Ignition

On every call for heat (system start), control performs internal safe-start check. If flame simulating condition is present, system will not start.

During normal start, control opens first (pilot) valve operator of gas control, which allows gas to flow to pilot burner. At same time, electronic spark generator in control produces 15,000 Volt spark pulse output (open circuit). This voltage produces spark at igniter sensor rod which ignites pilot burner. If pilot flame does not light or presence of pilot flame is not detected back through flame-rod, control will not open second (Main) valve operator of gas control. Control will continue to try to ignite pilot burner until either flame is detected or thermostat (controller) is set down below call for heat.

#### Main Burner Operation

When pilot flame is established, flame rectification circuit is completed to burner ground. Control flame sensing circuit detects flame current, shuts off spark generator and opens second (Main) valve operator to allow gas to flow to main burners. Pilot flame ignites main burner conventionally.

**IMPORTANT:** Electronic control module cannot be repaired. If troubleshooting procedure indicates malfunction in control, control must be replaced. Intermittent Pilot systems should be serviced only by trained, experienced service technicians.

#### Preliminary Check

Following visual checks should be made before troubleshooting and after maintenance.

1. Check power switch.
2. Manual shutoff valves in gas line to boiler must be open.
3. Make sure all wiring connections are clean and tight.
4. Review control's normal sequence of operation.

### System Troubleshooting

Start system by setting thermostat or controller above room temperature and observe system response.

Establish type of system malfunction or deviation from normal operation by using Pilot System Troubleshooting Table, in following section.

Use table by following questions in boxes. If condition is true (answer is yes), go down to next box. If condition is not true (answer is no), go to box alongside.

Continue checking and answering conditions in each box until problem and/or repair is explained. Use Component Checks section, see below, as necessary, to perform system checks.

After any maintenance or repair, troubleshooting sequence should be repeated until procedure ends with normal system operation.

### COMPONENT CHECKS

#### Check Spark Ignition Circuit

Electronic module and step-up transformer in control provides spark ignition at 15,000 V (open circuit). Check circuit at control module as follows:

1. Turn off manual gas valve to prevent flow of gas.

#### **WARNING**

Electrical shock hazard. Do not touch either end of jumper or stud terminal, high voltage circuit. Failure to follow these instructions could result in death or serious injury.

2. Disconnect ignition cable at control stud terminal to isolate circuit from pilot burner/igniter-sensor, and prepare short jumper lead using heavily insulated wire, such as ignition wire.
3. Energize control and touch one end of jumper firmly to control ground terminal (GND). (**Do not disconnect existing ground lead.**) Move free end slowly toward stud terminal to establish spark. Pull lead wire slowly away from stud. Note length of gap at which arcing discontinues.
4. Arc length of 1/8 inch (3.2 mm) or more indicates satisfactory voltage output. If no arc can be established or maximum gap is less than 1/8 inch (3.2 mm), replace control.

**CAUTION**

**WHAT TO DO IF YOU SMELL GAS**

- Do not try to light any appliance.
- Do not touch any electrical switch; do not use any phone in your building.
- Immediately call your gas supplier from a neighbor's phone. Follow gas supplier's instructions.
- If you cannot reach your gas supplier, call the fire department.

**Ignition Cable Check**

Cable must not run in continuous contact with a metal surface or spark voltage will be greatly reduced. Connections to the stud terminal on the control and on the igniter-sensor must be clean and tight. Loose connections may not conduct a flame current even though the ignition spark is satisfactory. Check the electrical continuity of the cable.

**Check Grounding**

A common ground is required for the pilot burner/igniter-sensor mounting bracket, and the GND terminal of the control. If the ground is poor or erratic, safety shutdown may occur occasionally even though operation is normal at the time of the checkout. Therefore, if nuisance shutdowns occur, be sure to check the grounding.

**Startup And Checkout**

**NOTE:** If any component in the system fails, the system will not operate. If the system does not perform as outlined in Start System, below, refer to the Pilot System Trouble-shooting Table.

**Start System**

1. Turn on power to the control(s) and turn off gas supply.
2. Check control(s) operation as follows:
  - A. Set the Thermostat or controller above room temperature to call for heat.
  - B. Watch for spark at the pilot burner(s).
3. Turn on gas supply.
4. System should start as follows:
  - A. Spark will turn on and pilot gas valve will open at once. Pilot burner(s) should ignite after gas reaches the pilot burner(s).
  - B. Spark ignition should cut off when pilot flame is established.
  - C. Main gas valve should open and main burners should ignite after gas reaches the burner ports.

**NOTE:** Light-off may not be satisfactory until the gas input and combustion air have been adjusted.

**DANGER**

Fire Hazard. Do not use matches, candles, open flames, or other methods providing ignition source. Failure to comply will result in death or serious injury.

**Pilot Flame Adjustment**

Pilot flame should envelop 3/8 to 1/2 inch of tip of insulated rod on igniter-sensor. If adjustment is required, remove pilot adjustment cover screw and turn inner adjustment screw clockwise to decrease or counterclockwise to increase pilot flame. Be sure to replace cover screw after adjustment to prevent possible gas leakage.

**Figure 41 - Proper Flame Adjustment**

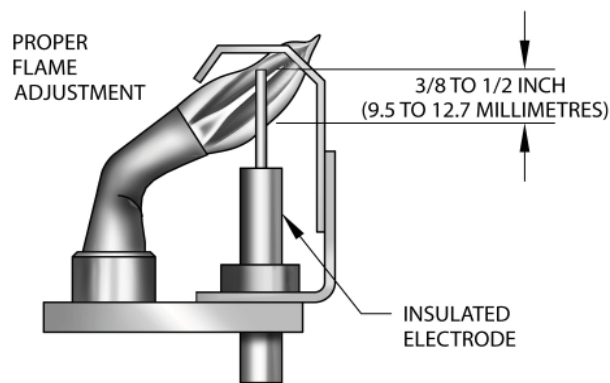

Ignition system safety shutoff device must be tested after placing boiler in operation. Disconnect sensor wire from ignition module. Burner operation should stop.

## PILOT SYSTEM TROUBLESHOOTING TABLE

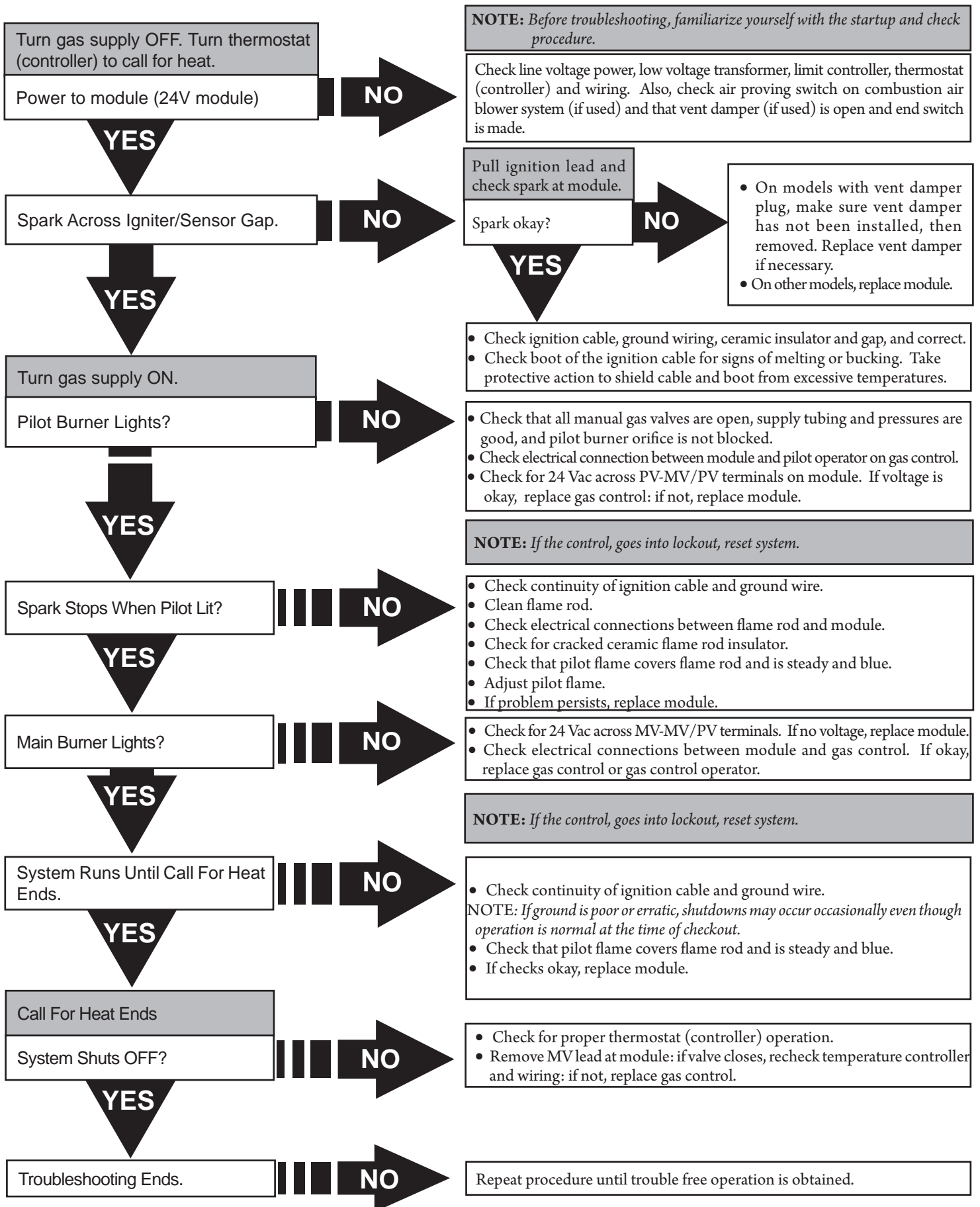

**NOTICE**

Do not exceed the Input rate stamped on the nameplate of boiler located on End Jacket Panel.  
Make certain primary air supply to Main burners is properly adjusted for complete combustion.

**Check Burner Input**

Check boiler for proper Btu input rate.

If boiler is shut down for service, gas and electric must be off for 5 minutes before relighting.

**To check boiler for proper Btu Input proceed as follows:** With main burners operating, measure the gas Input to the boiler by reading the meter. Be sure all other appliances connected to the same meter are shut off. Rate of gas flow (cu. ft. per hour) multiplied by the Btu value of the gas should check with the Btu Input shown on the nameplate of the boiler. If it is not within +/- 2%, adjust Pressure Regulator to obtain the desired flow (stem for adjustment is under the cap in the top of the regulator). **TURN CLOCKWISE TO INCREASE INPUT AND COUNTERCLOCKWISE TO DECREASE THE INPUT RATE.**

**NOTE:** *The adjustment screw is plastic and may require slightly greater turning force than metal threads.*

Be sure to replace Regulator Cap.

**High Limit Control**

While boiler is operating, set high limit control below boiler water temperature and main burners should shut off. Return control to normal setting and main burners should start again.

**Pressure Relief Valve**

You must have pressure relief valve on the boiler. The Relief Valve on water boilers is set at 30 psig, (50 psig optional.) Run a pipe from the pressure relief valve outlet to an open drain. This pipe must be of same size as outlet on valve and open end must not be threaded. This drain must be run in an area not subject to freezing. Failure to do so may cause water damage or injury should valve release.

If valve discharge occurs, or if valve fails to open as described above, contact an authorized contractor or qualified service technician to replace the relief valve and inspect the heating system to determine the cause, as this may indicate an equipment malfunction.

This valve should be tested every month during periods of boiler operation, and at the beginning and end of any extended non-service period. Prior to testing, make certain discharge pipe is properly connected to valve outlet and arranged so as to contain and safely dispose of boiler discharge. Test at normal system operating pressure. Hold the trip lever fully open for at least five seconds in order to flush free any sediment that may lodge on the valve seat. Then permit the valve to snap shut.

**Burner And Pilot Flame**

We recommend that you make a periodic visual check of the burners and pilot flame, **Figure 42**. During this visual check look for any deterioration from corrosion or other sources of the burners, pilot burners and boiler base frame. Also be sure the boiler base interior and exterior are clean. This visual check should be made once every month during the heating season by the owner and once a year by a competent service technician to assure safe and trouble-free operation.

**Figure 42 - Pilot and Flame**

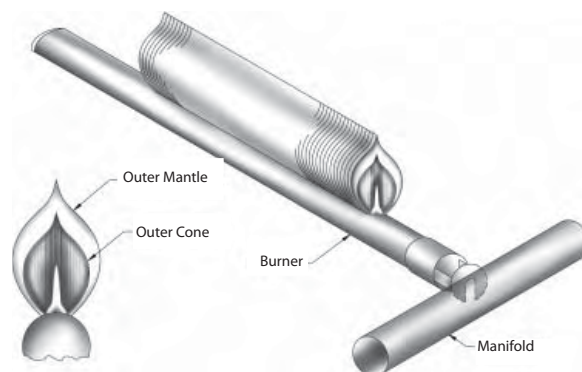
**Burner And Pilot Flame**

Under normal operating conditions, with the burners adjusted properly, it should not be necessary to clean the boiler flue gas passages. However, to assure trouble-free operation, we recommend that you have the flue passages, burner adjustments and operation of the boiler controls checked once each year by a competent service technician. If it becomes necessary to clean flue passages, first remove the burners and pilot(s) from the boiler. Refer to **Figure 13** in the **Installing Draft Hood Section** in the front of this instruction and remove the clean-cut cover panel on the draft hood. This will expose the flue passages. Clean flue passageways between the sections with flexible handle wire brush. Remove all dirt from bottom of boiler and reassemble all parts. Be sure to check tightness of pilot connection(s) and adjustment of pilot(s) and burner flames after reassembly.

### VENTING SYSTEM

Vent system is very important part of heating system. No boiler, however efficient its design, can perform satisfactorily if chimney that serves it is inadequate. Check your chimney to make sure that it is right size, properly constructed, clean and in good condition to ensure proper combustion and THAT NO HAZARD WILL DEVELOP. You must also provide enough FRESH AIR FOR COMBUSTION. LACK OF ENOUGH OXYGEN WILL CREATE A HAZARD. If your building is of tight construction, it may be necessary to add FRESH AIR DUCT to provide OXYGEN required (Refer to **Chart 2** in the front of this manual).

AT LEAST ONCE A MONTH DURING HEATING SEASON check to see that sections of vent pipe are secure at all joints and fittings. There should be at least two (2) sheet metal screws per joint.

Check to see that vent pipe slopes at least 1/4" per foot up from boiler to chimney. Vent pipe should be securely fastened to prevent sagging.

Vent Pipe should also be checked for any deterioration from corrosion or any other sources. *Refer to Venting and Combustion Air instructions in the front of this manual.*

## CLEANING AND MAINTENANCE

### Cleaning The New Steam Boiler

New steam boilers must be cleaned previous to or during the first few days of use in order to ensure efficient operation. The grease or oil used to lubricate the cutting tools or push nipples during the erection of new piping systems picks up sand and dirt causing a scum of fine particles and grease to accumulate on the surface of the water in all new boilers, The heavier particles carried in the grease may settle to the bottom of the boiler and form sludge. This condition, if permitted to remain in the boiler, tends to prevent the generation of steam, produces foaming and causes an unsteady water line. This unavoidable accumulation of oil and grease should be removed by blowing off the boiler as follows:

1. Install a surface blow-off connection of at least 1¼' nominal pipe size in boiler using the Skimming Tee shown in **Figure 35**. The blow-off line should extend to within 18" of the floor or to the sewer.
  - A. Insert a valve in the line close to the boiler.
2. Bring the water line to the center of the outlet.
  - A. Raise the temperature to a point just below steaming.
  - B. While the burners are on, open the valve in the skim line and then slowly feed clean water into the boiler adjusting the inlet water so that the boiler water remains hot.
  - C. Continue skimming until the water is clean.
3. Close valves in boiler feed line and skim line.
4. Bring the pressure in the boiler to about 10 lbs.
  - A. Turn off the burners.
  - B. Open the bottom drain valve permitting all the water to drain from boiler.
5. After the boiler has cooled, fill and flush out several times.
6. Fill to proper water level and ready for normal service.

**NOTE:** Use of soda or any alkali, vinegar or any acid is not recommended for cleaning heating boilers because it is difficult to completely remove them and injury may occur after the cleaning process has been completed.

### Boiler Water Treatment

In closed hot water heating systems, negligible amounts of make up water are used, and water treatment is not required.

In steam systems where the system is tight, free from leaks, and all the steam is returned to the boiler as condensate, the amount of make up water is small. Again, water treatment is not required.

On steam systems with less than 90% of the steam being returned as condensate, or with very hard or corrosive make up water, treatment may be desirable. Follow the recommendations of the ASME (American Society of Mechanical Engineers) Boiler and Pressure Vessel Code, Section VI, latest version.

### Between Heating Seasons

Boilers should not be drained between heating seasons. Boilers in closed hot water heating systems may be left as is. Steam boilers should be entirely filled with water during the summer months to exclude air.

### Low Water Cutoff(s)

Inspect low water cutoff(s) annually or as recommended by low water cutoff manufacturer. Flush float types per manufacturer's instructions.

### General Housekeeping

- Keep boiler area clear and free from combustible materials, gasoline and other flammable vapors and liquids.
- Keep boiler area clear of obstructions to flow of combustion and ventilation air.



**DUNKIRK BOILERS**

2201 Dwyer Avenue, Utica NY 13501  
web site: [www.ecrinternational.com](http://www.ecrinternational.com)