

MODELS

H₂OI30
H₂OI40
H₂OI40L
H₂OI50
H₂OI60
H₂OI60L
H₂OI80
H₂OI80C
H₂OI80HO
H₂OI80HOC
H₂OI115
H₂OI115C
H₂OI115HO
H₂OI115HOC

H₂O

INDIRECT-FIRED WATER HEATERS

INSTALLATION, OPERATION & MAINTENANCE MANUAL

FOR SINGLE WATER HEATER INSTALLATIONS

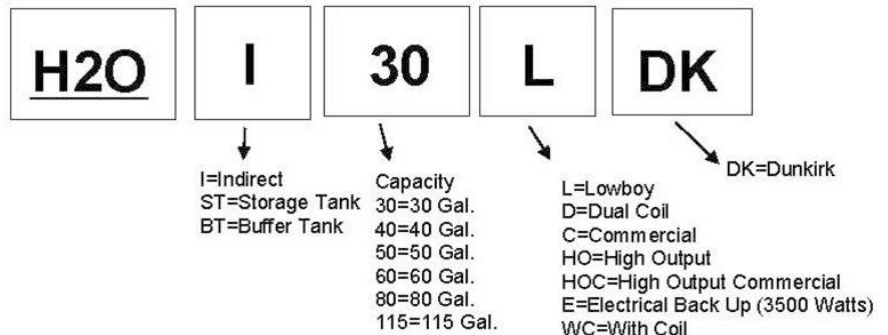

Intertek

Conforms to UL STD 174

Certified to CAN/CSA STD C22.2 No. 110-94

Information and specifications outlined in this manual in effect at the time of printing of this manual. ECR International reserves the right to discontinue, change specifications or system design at any time without notice and without incurring any obligation, whatsoever.



An ISO 9001-2008 Certified Company

ECR International, Inc.

2201 Dwyer Avenue, Utica NY 13501

web site: www.ecrinternational.com

P/N# 615000054, Rev. B [10/2011]

Table of Contents

I. General Information & Safety Instructions	2
II. Pre-installation Considerations	4
III. Piping.....	9
IV. Electrical.....	13
V. Operation.....	13
VI. Maintenance	16
VII. Troubleshooting	16

I. General Information

IMPORTANT INFORMATION – READ CAREFULLY

NOTE: Equipment shall be installed in accordance with those installation regulations required in the area where the installation is to be made. These regulations shall be carefully followed in all cases. Authorities having jurisdiction shall be consulted before installations are made. All wiring on water heaters shall be in accordance with the National Electrical Code and/or local regulations.

WARNING

Improper installation, adjustment, alteration, service or maintenance can cause property damage, personal injury, or loss of life. Read and understand the entire manual before attempting installation, start-up, operation, or service. Installation and service must be performed only by an experienced, skilled installer or service agency.

This water heater contains very hot water under high pressure. Do not unscrew any pipe fittings or attempt to disconnect any components of this water heater without positively assuring that the water is cool and has no pressure. Always wear protective clothing and equipment when installing, starting up or servicing this water heater to prevent scalding injuries. Do not rely on the pressure and temperature gauges to determine the temperature and pressure of the water heater. This water heater contains components that become very hot when the boiler is operating. Do not touch any components unless they are cool.

Failure to follow all instructions in the proper order can cause personal injury or death. Read all instructions, including all those contained in component manufacturers' manuals before installing, starting up, operating, maintaining, or servicing the water heater.

CAUTION

To reduce the risk of excessive pressures and temperatures in this water heater, install temperature and pressure protective equipment required by local codes but no less than a combination temperature relief valve certified by a nationally recognized testing laboratory that maintains periodic inspection of production of listed equipment or materials, as meeting the requirements for Relief Valves and Automatic Shutoff Devices for Hot Water Supply Systems, ANSI Z21.22- latest edition. This valve must be marked with a maximum set pressure not to exceed the marked working pressure of the water heater. Install the valve into an opening provide and marked for this purpose in the water heater, and orient it or provide tubing so that any discharge from the valve will exit only within 6 inches above, or at any distance below, the structural floor, and cannot contact any live electrical part. The discharge opening must not be blocked or reduced in size under any circumstances.

Heat transfer medium must be water or other non-toxic fluid having a toxicity rating or class of 1, as listed in clinical Toxicology of Commercial Products, latest edition. The pressure of the heat transfer medium must be limited to a maximum of 60 psig by a listed safety or relief valve.

⚠ DANGER

DO NOT store or use gasoline or other flammable vapors or liquids in the vicinity of this or any other appliance. If you smell gas vapors, DO NOT try to operate any appliance - DO NOT touch any electrical switch or use any phone in the building. Immediately, call the gas supplier from a remote located phone. Follow the gas supplier's instructions or if the supplier is unavailable, contact the fire department.

IMPORTANT SAFETY INSTRUCTIONS

WARNING – When using electrical appliances, basic safety precautions to reduce the risk of fire, electric shock, or injury to persons should be followed, including:

READ ALL INSTRUCTIONS BEFORE USING THIS BUFFER TANK.

1. This water heater must be grounded. Connect only to properly grounded outlet. See "GROUNDING INSTRUCTIONS" found in Section IV.
2. Install or locate this water heater only in accordance with the provided installation instructions
3. Use this water heater only for its intended use as described in this manual.
4. Do not use an extension cord set with this water heater. If no receptacle is available adjacent to the water heater, contact a qualified electrician to have one properly installed.
5. As with any appliance, close supervision is necessary when used by children.
6. Do not operate this water heater if it has damaged connections or plug, if it is not working properly, or if it has been damaged or dropped.
7. This water heater should be serviced only by qualified personnel. Contact nearest authorized service facility for examination, repair, or adjustment.

Hazard Definitions

The following defined terms are used throughout this manual to bring attention to the presence of hazards of various risk levels or to important information concerning the life of the product.

⚠ DANGER Indicates a presence of hazards that will cause severe personal injury, death or substantial property damage.

⚠ WARNING Indicates the presence of hazards that can cause severe personal injury, death or substantial property damage.

⚠ CAUTION Indicates presence of hazards that will or can cause minor personal injury or property damage.

NOTICE Indicates special instructions on installation, operation or maintenance that are important but not related to personal injury or property damage.

II. Pre-installation Considerations

Inspect shipment carefully for signs of damage. All equipment is carefully inspected and packed. ECR's responsibility ceases upon delivery of the water heater to the carrier in good condition. Any claims for damage or shortage, must be filed immediately against the carrier by the consignee. No claims for variances or shortages will be allowed by the Manufacturer, unless they are presented within sixty days after receipt of the equipment.

Installation must conform to the requirements of the authority having jurisdiction. In the absence of such requirements, installation must conform to the National Plumbing Code and the National Electrical Code ANSI/NFPA No. 70, current edition.

IMPORTANT CONSIDERATIONS BEFORE INSTALLATION

1. Water Heater Sizing.

Choose the water heater model based on the expected water usage for the given site. The average residence with one shower or more will require a Model 40 or larger. The Model 30 should only be considered for residences with minimal water demand, or for commercial applications without showers. See tables on pages 17 and 18.

Consult ASHRAE sizing guides and other references.

Factors that increase water demand dramatically include high flow shower heads, hot tubs, and the use of more than one shower at a time. Increase the tank size if these factors are present. Consult ASHRAE sizing guides or other references.

Dimensions, weights, ratings, and capacities are outlined in Tables 1 and 2.

2. Boiler Sizing.

The water heater will provide the rated performance only if it is used with a boiler with a heating capacity of at least as much as the capacity ratings in Table 2. If the boiler has less capacity, the water heating output will be reduced. To determine performance with other boiler outputs, refer to the expanded capacity tables in the Appendix.

TABLE 1 Dimensions and Capacities

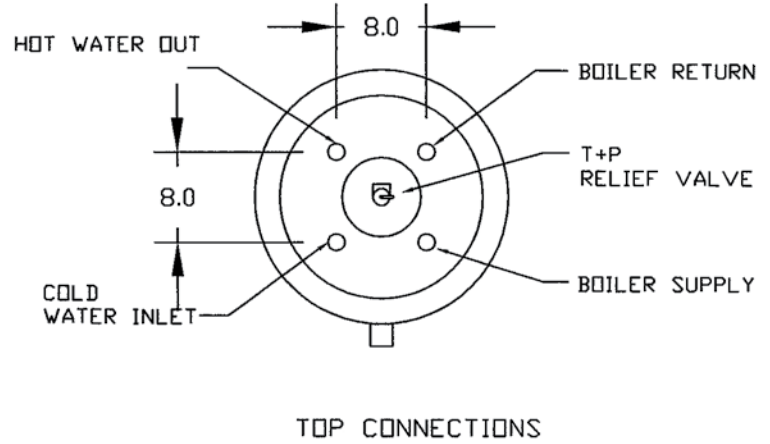
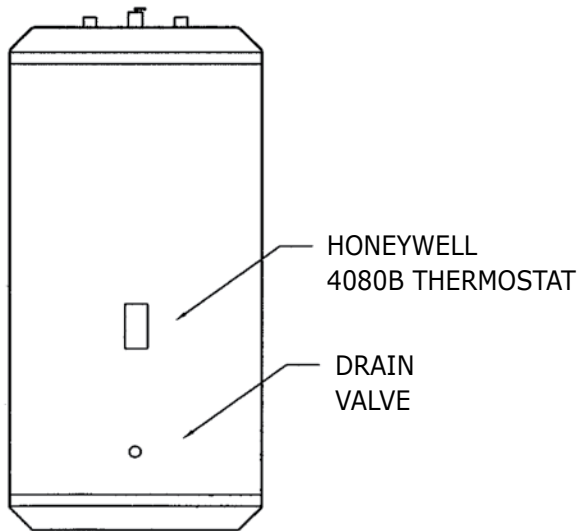

Model	Storage Volume	Coil Heating Surface	Dimensions (Inches)		Piping Connections		Max. Working Pressure	Approx. shipping Wt.
	Gals.	Sq. Ft.	Ht.	Dia.	Cold/Hot In/Out	Heat Source Supply/Return	(psi)	Lbs.
H2OI30	30	7.0	32.0	22.5	3/4	1	150	85
H2OI40	40	7.5	42.0	22.5	3/4	1	150	100
H2OI40L	42	7.1	34.0	26.0	3/4	1	150	100
H2OI50	60	8.0	52.0	22.5	3/4	1	150	110
H2OI60	60	8.4	60.0	22.5	3/4	1	150	125
H2OI60L	60	7.5	44.0	26.5	3/4	1	150	120
H2OI80	80	8.0	54.0	26.5	1	1	150	140
H2OI115	115	8.9	72.0	26.5	1	1	150	175
High Output Units								
H2OI80HO	80	13.5	54.0	26.5	1	1	150	155
H2OI115HO	115	14.4	72.0	26.5	1	1	150	190
H2OI80HOC	80	13.5	54.0	26.5	1½	1¼	150	155
H2OI115HOC	115	14.4	72.0	26.5	1½	1¼	150	190

Table 2 - Ratings

Model	Max. First Hour Rating		Continuous Rating		Boiler Output Needed	Min. Boiler Water Flow Through Coil	Pressure Drop Through Coil
	Gal/Hr. @		Gal/Hr @		(BTU/Hr)	Gal/Min	(Ft. Water)
	140F	115F	140F	115F			
H2OI30	182	242	155	215	116,200	10.0	2.7
H2OI40	202	266	166	230	124,500	10.0	2.9
H2OI40L	193	251	157	215	117,900	10.0	2.8
H2OI50	222	290	177	245	132,800	10.0	3.1
H2OI60	240	311	186	257	139,400	10.0	3.2
H2OI60L	220	284	166	230	124,500	10.0	2.9
H2OI80	257	328	185	256	138,600	12.0	3.7
H2OI115	309	388	206	285	154,200	12.0	4.0
High Output Units							
H2OI80HO	386	507	314	435	235,670	15.0	9.0
H2OI115HO	439	568	336	465	251,780	15.0	9.5
H2OI80HO(C)	386	507	314	435	235,670	15.0	9.0
H2OI115HO(C)	439	568	336	465	251,780	15.0	9.5

Table 2 For different ratings refer to table on page 18.

3. Circulator Sizing.

Refer to Table 2 for the minimum flow through the water heater coil and the pressure drop at minimum flow. Calculate the pressure drop across all piping and fittings connected to the water heater zone. Be sure to include all zone valves, check valves, and shut-off valves. It is recommended that the water heater zone be piped with 1" pipe around the entire loop on typical residential sites.

A. System Zone Control

The water heater must be installed as a separate zone from the space heating system. The water heating zone's piping and circulator must be sized for the minimum flow rate with all the zones in use and a maximum flow with only the water heater in use. Zone control with circulators normally gives the best performance.

The three most common systems are:

1. Zone Circulators - Space heating zones use a circulator for each zone. The water heater is controlled with an additional circulator.
2. Hybrid System - Space heating zones use zone valves for each zone. The water heater is controlled with an additional circulator.
3. Zone Valves - Space heating zones use zone valves for each zone. The water heater is controlled with an additional zone valve. Select a valve with a low pressure drop, and assure minimum flow with adequate pipe sizing.

B. Priority or Non-Priority for Hot Water

1. **Option 1 – Priority.** The demand for space heating is interrupted until the hot water demand is satisfied. This option provides the maximum delivery of hot water.
Priority is recommended when:
 - A. The boiler output is less than 100,000 Btu per hour, or
 - B. The boiler output required to satisfy the hot water demand is more than 50% of the boiler output needed to satisfy the space heating demand, or
 - C. When an interruption in space heating can be tolerated during long domestic hot water draws.
In most cases the delay in space heating will not be noticed because of the rapid recovery of the water heater. It must be recognized however that certain water heater malfunctions, such as a failed thermostat or circulator, could delay space heating indefinitely.
2. **Option 2 – Non-Priority.** Boiler output is divided between space heating and water heating. Heating of domestic hot water can be reduced during simultaneous space and water heating demands. The amount of reduction depends on boiler output, number of space heating zones calling, and the amount of boiler water flow split between space heating and water heater zones.

C. Locating the water heater.

Water heater should be located in an area where water leakage from the tank or connections will not result in damage to areas adjacent to the water heater or to lower floors of the structure. When such a location can not be avoided, a suitable drain pan must be installed under the water heater, and the drain pan must be connected to a drain.

Water heater should be installed as close to the boiler as is practical for easy access for service. Unit is designed for installation on combustible flooring and in alcoves, closets, etc.

The minimum clearances from combustible surfaces are:

- Bottom ----- 0"
- Left, right, and rear sides ----- 0.5"
- Front ----- 0.5"
- Top ----- 6"

The minimum clearances for service are:

- Bottom ----- 0"
- Left, right, and rear sides ----- 3"
- Front ----- 6"
- Top ----- 6"

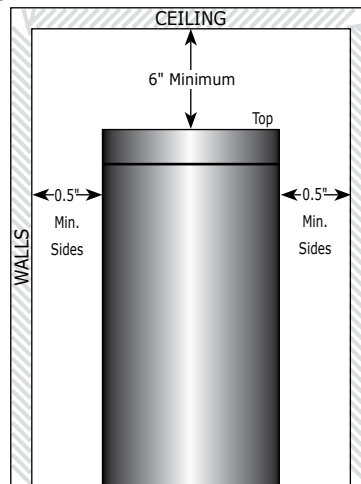

Front View

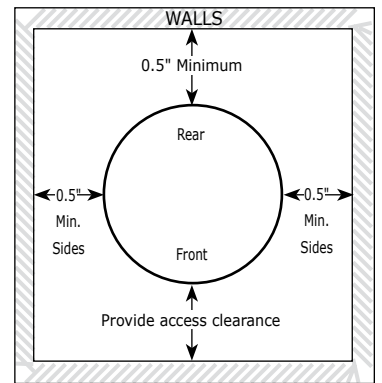

Top View

D. Additional recommended components

1. Shut-off valves. Allows the isolation of the water heater from the boiler system during service.
2. Unions. Allows for easy locating or removal.
3. Vacuum breaker. Protects water heater from collapse if a hot tank is valved off to service other components in the system.
4. Thermal expansion tank. If the water heater is installed in a closed water supply system, such as a system having a back flow preventer in the cold water supply line, the installation of a thermal expansion tank is required.

E. Removing the Existing Domestic Water Heating System

1. External Tankless Heater- Disconnect all lines to the boiler and plug the boiler fittings. Disconnect the external heater from the boiler piping, and the domestic piping systems.
2. Internal Tankless Heaters- Disconnect the domestic piping. Do not plug the cold water or the hot water fittings in the internal tankless coil. Leave the coil in the boiler with the cold and hot water fittings open to prevent pressure build-up in the coil.

F. Water Quality

Improper water quality will reduce the expected life of the water heater. Hard water, sediment, high or low Ph, and high levels of chlorides in the domestic water should be avoided. Sediment and hard water will eventually coat the heating coil inside the water heater and reduce the rate of hot water production and may, eventually cause a failure. High or low Ph and/or high chloride concentrations will cause corrosion and eventually failure. A filter is strongly recommended where sediment is present in the water. A water softening system is recommended for areas with hard water.

In an area where the water quality is not known, a water quality test should be performed.

WARNING:

Do not operate the water heaters in areas where the Ph is above 8.0 or below 6.0, and/or with chloride concentrations greater than 100 parts per million (ppm). ECR's standard warranty does not cover problems caused by improper water Ph or excessive levels of chlorides.

III. Piping

A. Domestic water piping. See Figure 1.

1. Shut off the cold water supply at the main shutoff valve.
Open one or more faucets to relieve the pressure. Open the system drain, leaving the faucets open.
Drain the domestic water system.
2. Position the water heater in the final location.
3. Connect the cold water supply piping.
Install piping onto cold inlet connection.
Connect to cold water supply connection using a union, a heat trap, a shut-off valve, an expansion tank (where required), a back flow preventer (where required), and a filter (recommended to prevent sediment buildup).
4. Connect the domestic hot water piping.
Install piping on to hot water supply connection using a union, a heat trap, a vacuum breaker, and a shut-off valve.
5. Pipe relief valve discharge so discharge from valve will exit only within 6 inches above, or at any distance below, the structural floor, and cannot contact any live electrical part. Discharge opening must not be blocked or reduced in size under any circumstances. Refer to local codes.
6. Fill the water heater tank.
Open all faucets to allow air to purge from the tank and piping. Remove screens on faucets.
Open domestic hot water shut-off valve.
Open cold water inlet shut-off valve.
Purge all of the air from the domestic water system. Allow water to run so the tank is completely purged of any debris. Run the water long enough to change at least five tank volume changes. Close all faucets. Reinstall all of the screens in the faucets.
Check the system for leaks. Repair as required using materials listed for potable water applications.

B. Water boiler piping. See Figures 2 and 3.

1. Determine where the boiler, the space heating, and the water heater connections should be made based on the type of piping system that is either in place, or is to be installed for a new hydronic system installation. See Figure 2, Boiler Water Piping with Zone Circulators, and Figure 3, Boiler Water Piping with Zone Valves.
2. It is recommended that 1" pipe and 1" zone valves be used on the water heater zone.

Zone Circulator System

For space heating systems that use Zone Circulators, refer to Figure 2. The water heater connection labeled "BOILER SUPPLY" should be piped to the boiler supply piping after the air purger and before the space heating takeoffs. Mount the water heater circulator as close as possible to the water heater, and make sure the flow arrow points toward the water heater. The use of shut-off valves is recommended for future service convenience.

The water heater connection labeled "BOILER RETURN" should be piped to the boiler return piping as close to the boiler as possible and after any flow control or check valves in the space heating return piping. The use of a union and a shut-off valve is recommended. The use of a check valve is required to prevent back flow through the water heater during operation of the space heating system.

Zone Valve System

For a space heating system that uses Zone Valves, refer to Figure 3. The water heater connection labeled "BOILER SUPPLY" should be piped to the boiler supply piping after the air purger and before the space heating circulator. Mount the water heater circulator as close as possible to the water heater, and make sure the flow arrow points toward the water heater. The use of a shut-off valve is recommended for future service convenience.

The water heater connection labeled "BOILER RETURN" should be piped to the boiler return piping as close to the boiler as possible and after any flow control or check valves in the space heating return piping. The use of a union and a shut-off valve is recommended. The use of a check valve is required to prevent back flow through the water heater during operation of the space heating system.

Thermal expansion tank – Optional

Required if cold water line is equipped with a backflow preventer or pressure reducing valve.

Water hammer arrester – Optional

⚠ WARNING Dishwashers, clothes washers, and fast-closing positive shutoff valves incorporated in the system all contribute to creating water hammer. Install a water hammer arrester to prevent damage to pipes and appliances. See control manufacturer's instructions for application and installation.

Unions

Use dielectric unions or couplings to protect hot and cold water fittings from corrosion when connecting dissimilar materials such as copper and galvanized pipe.

Backflow preventer – Optional

Required for Commonwealth of Massachusetts

Vacuum breaker – Optional

Required for Commonwealth of Massachusetts

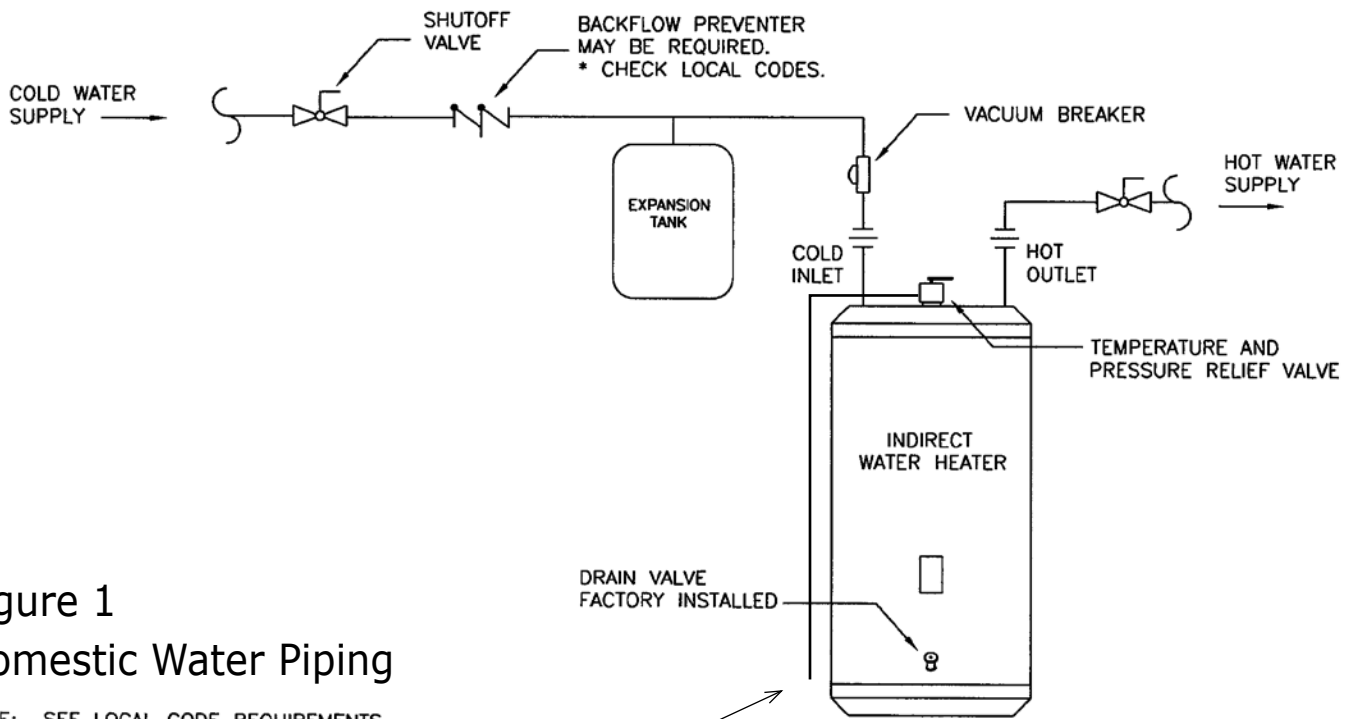

Pipe Relief Valve Discharge to within 6" of floor, see Section III Notes.

Figure 1
Domestic Water Piping

NOTE: SEE LOCAL CODE REQUIREMENTS.
BACKFLOW PREVENTER CONFORMING TO CMR 248,
MASS. STATE CODE REQUIRED IN MASSACHUSETTS.

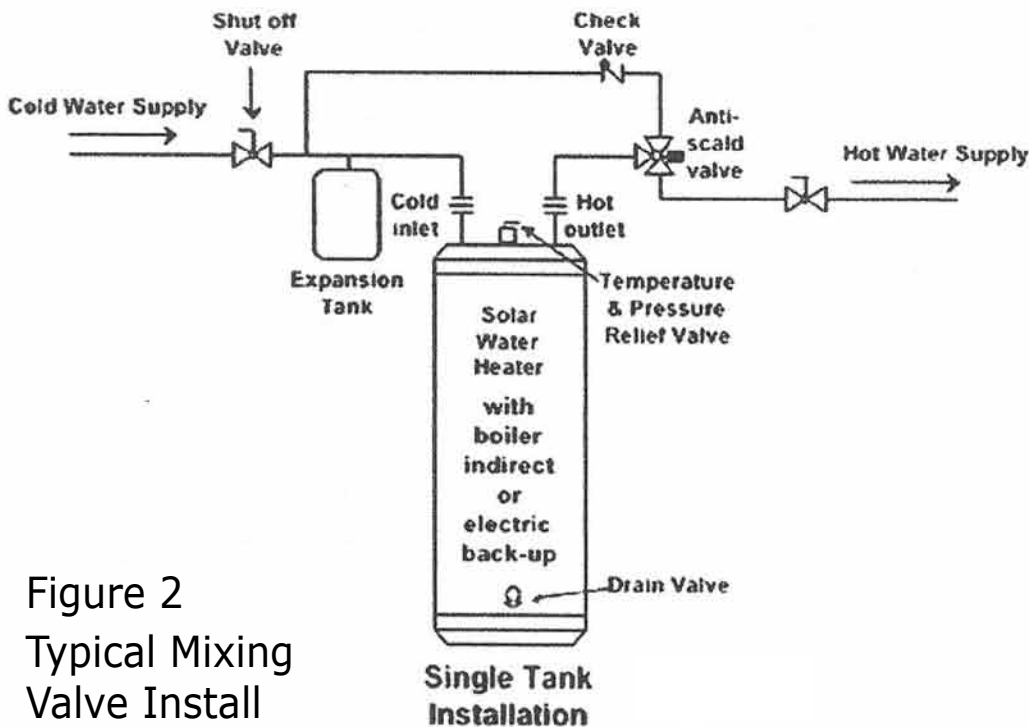

Figure 2
Typical Mixing Valve Install

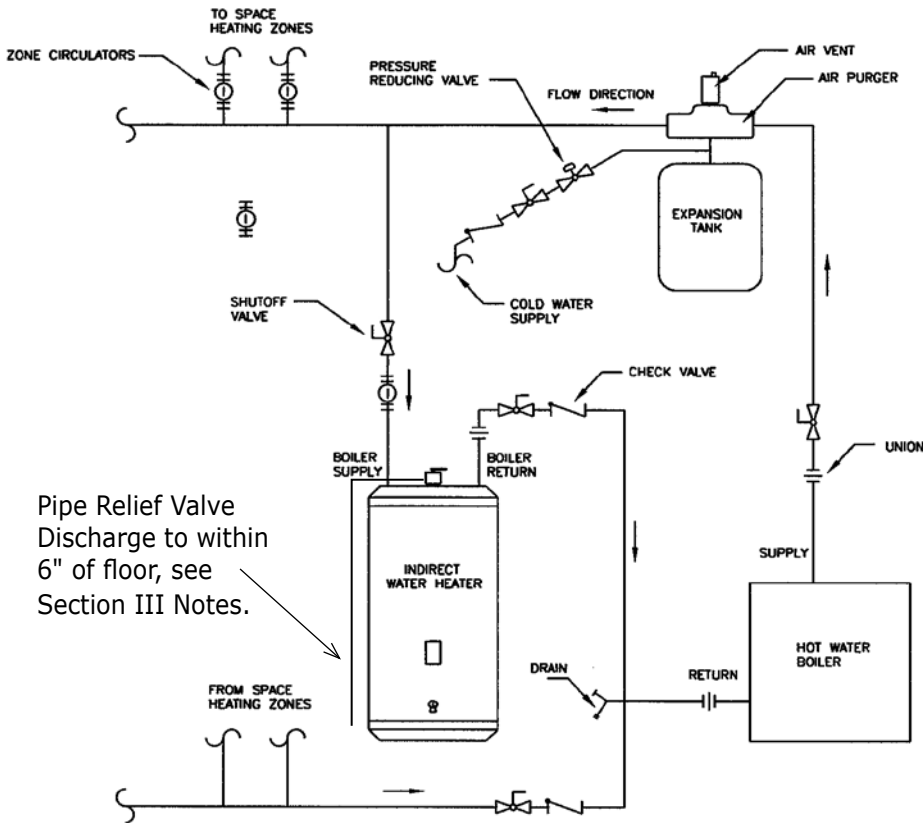

FIGURE 3 - BOILER WATER PIPING WITH ZONE CIRCULATORS

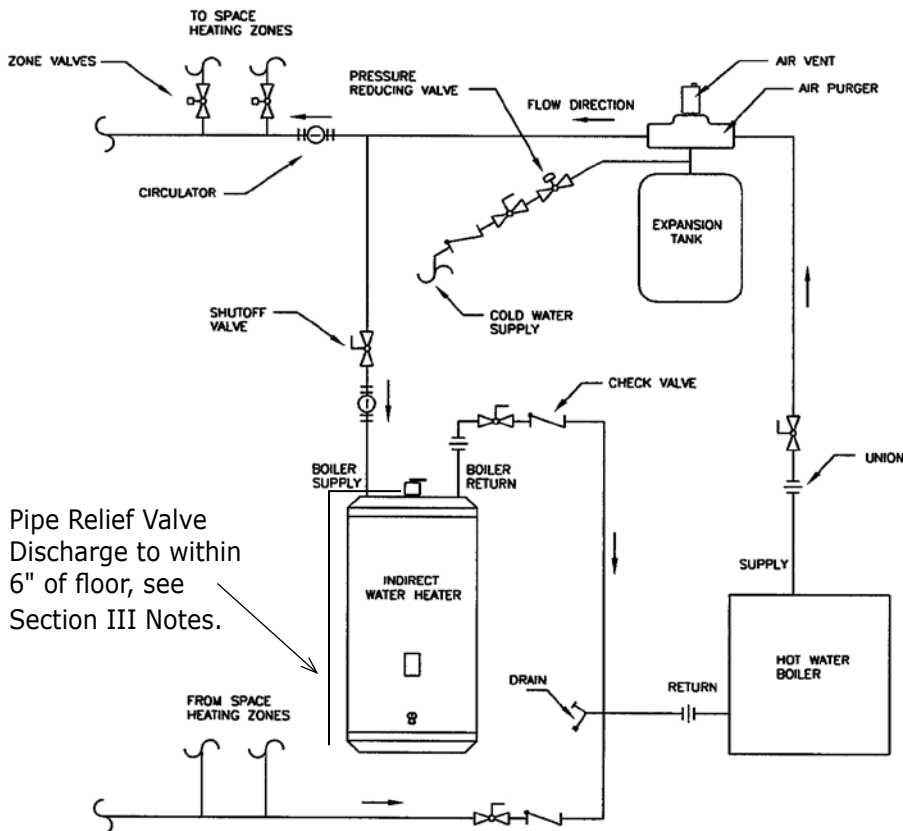

FIGURE 4 - BOILER WATER PIPING WITH ZONE VALVES



Hot Water Can Scald!

Water heated to temperature for clothes washing, dish washing and other sanitizing needs can scald and cause permanent injury.

Children, elderly, and infirm or physically handicapped persons are more likely to be permanently injured by hot water. Never leave them unattended in bathtub or shower. Never allow small children to use a hot water tap or draw their own bath.

- If anyone using hot water in the building fits the above description, or if state laws or local codes require certain water temperatures at hot water taps, you must take special precautions:
 - Use lowest possible temperature setting.
 - Install some type of tempering device, such as an automatic mixing valve, at hot water tap or water heater. Automatic mixing valve must be selected and installed according to manufacturer's recommendations and instructions.

Water passing out of drain valves may be extremely hot. To avoid injury:

- Make sure all connections are tight.
- Direct water flow away from any person.

IV. Electrical

1. Install electric wiring and grounding in accordance with the National Electrical code and local regulations.
2. All water heaters are supplied with a thermostat.
3. Refer to wiring schematics for separate circulator wiring.
Refer to wiring schematics for zone valve wiring.
Reference should be made to the Installation Manual for the boiler as well.

V. Operation

Startup

After the water heater has been plumbed and wired, and the boiler water piping is purged of air, the water heater is ready to be started.

1. Follow boiler installation instructions to place boiler in operation.
2. The tank thermostat is factory pre-set to 125 degrees F and will call for heat if the water in the tank is lower than 125.
3. On a call for heat, the tank thermostat contacts close to start the water heater zone circulator and the boiler.
4. After the tank has reached the temperature setting, the tank thermostat opens and de-energizes the circulator and the boiler. If there is a call for space heating, the boiler will continue to run until the room thermostats are satisfied.

Temperature Adjustment



The tank thermostat controls the maximum water temperature in the water heater. If it is set too high, the resulting hot water can cause painful scalding with possible serious and permanent injury. The temperature at which this occurs varies with a person's age, and the length of time in contact with the hot water. The slower response time of infants, older, or handicapped people increases the hazard for them.

It is recommended that the thermostat be set for the lowest possible temperature that satisfies your needs. This will also provide you with the lowest energy consumption and cost.

Check the water temperature at a hot water faucet soon after the tank thermostat has satisfied, and the circulator and the boiler have turned off. Adjust as needed.

Lowering the thermostat setting will not have an immediate effect on the water temperature because the stored water will have to be used and the thermostat must go through the cycle of heating cold water and satisfying at the new, lower temperature. Additional temperature checks should follow the completion of a heating cycle. Further adjustments may be required after you have used the water heater.



Studies have indicated that dangerous bacteria including **legionella pneumophila** can form in potable water distribution system if certain minimum water temperatures are not maintained. Contact your local health department for more information.



Argo offers a broad line of controls for water heating and multiple zone boiler heating applications.

Please check out our web site at <http://www.argoindustries.com> for applications information and comprehensive wiring diagrams.

A typical wiring diagram is shown below. This is a multi-zone application using zone pumps with programmable domestic hot water priority using our ARM-4P Panel.

Product features include:

1. Build in transformer that will support up to 15 zones. Transformer has electronic fuse protection to prevent transformer overloading.
2. Data Port Terminal for easy connection to other Argo control products.
3. Expansion module plug-in allowing easy expansion to more zones.
4. Priority Zone Safety Timer. If the priority zone calls for more than 30 minutes the priority zone feature will turn off allowing all zones to operate independently preventing freeze ups if water heater has a problem.
5. Plug in replacement relays for long life and easy servicing with 1/3 HP pump motor ratings.

INDIRECT WATER TANK TO ARM-4P CONTROL

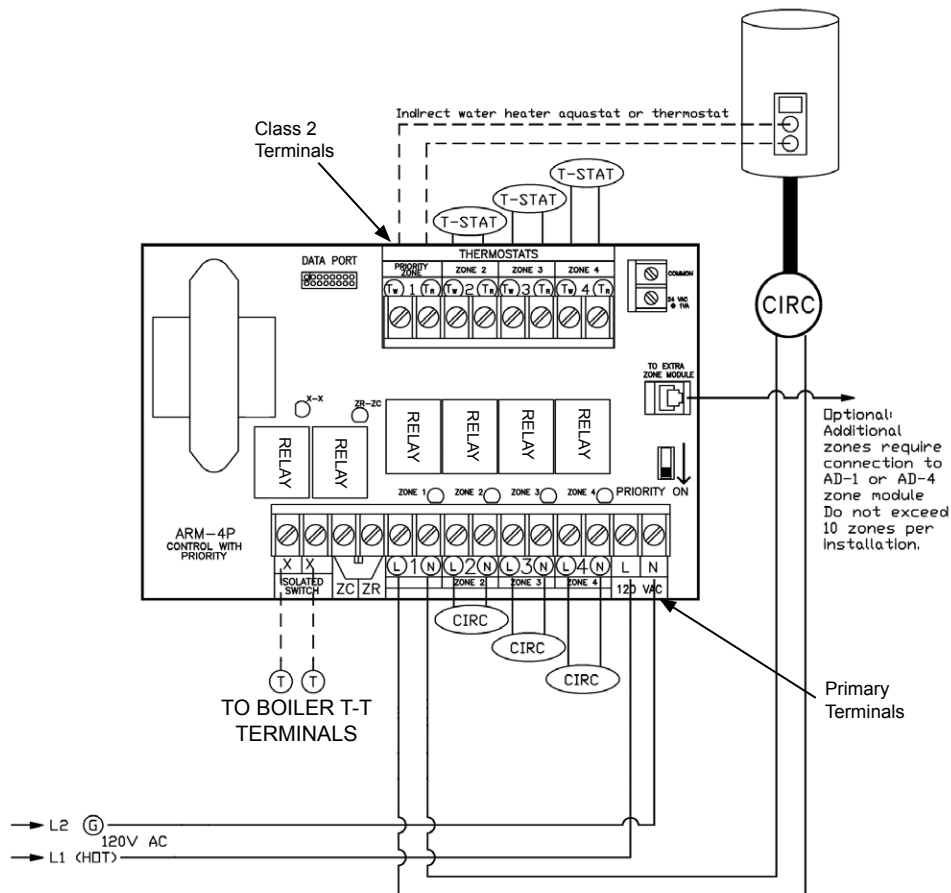

ZONE VALVE WIRING

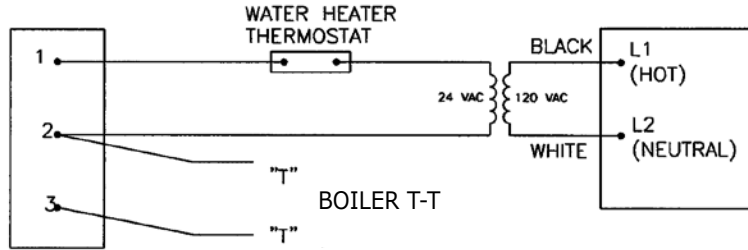

3-WIRE ZONE VALVE

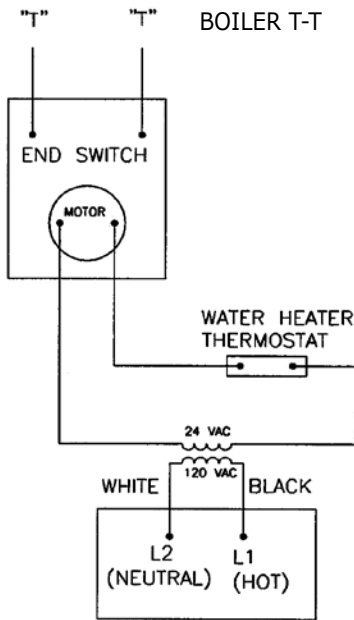

4-WIRE ZONE VALVE WITH 24 VOLT MOTOR

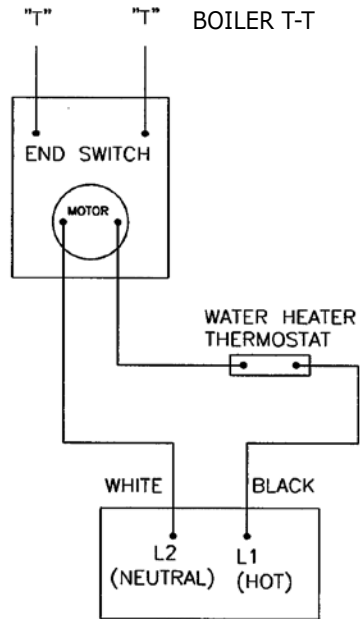

4-WIRE ZONE VALVE WITH 120 VOLT MOTOR

VI. Maintenance

The water heater is intended to provide many years of reliable service. Components, such as thermostats and relief valves, may be subject to failures that require service. Depending on the quality of the water supply, sediment and/or scale may coat the heating coil in the tank and reduce hot water recovery rate. Failure to use the correct procedures or parts can result in unsafe operation.

The owner should arrange to have the following inspections and simple maintenance procedures done at the suggested frequencies.

1. Boiler and Domestic Water Piping (Annual)
Check all piping for signs of leakage at the joints, unions and shut-off valves. Repair as required.
2. Temperature and Pressure Relief Valve (Annual)
3. Sediment (Annual except where harsh water quality may require more frequent service)
Depending on water conditions, a varying amount of sediment may collect in the tank. Levels requiring service are indicated by a small temperature difference between the boiler supply and return lines, and a reduced recovery rate. Repeated flushing usually clears such material. As a preventive measure, water should be drawn from the drain valve until it runs clear and the installation of a water filter should be considered.
4. Scale (Annual)
Hard water may cause scale buildup on the outside of the heating coil inside the tank. A water softener will prevent this problem. Symptoms are identical to sediment buildup. If repeated flushing does not resolve the problem, chemical cleaning may be required. Contact a qualified contractor.

VII. Troubleshooting

PROBLEM	CAUSE	SOLUTION
No hot water at faucets	Boiler does not operate.	Press reset button Check main cut-off switch Check fuses or breakers. Check power supply to boiler.
	Circulator does not operate	Check power supply to pump.
	Improper thermostat setting	Turn thermostat to a higher setting.
	Zone valve does not open	Check power supply and valve
	Electrical problem	Check fuses and replace. Check circuit breaker and reset. Check power supply
	Clogged filter	Clean or replace filter.
Insufficient or runs out of hot water at the faucet	Thermostat setting too low.	Turn the thermostat to a higher setting.
	Undersized boiler with no priority to domestic water heating.	Rewire for priority.
	Peak draw of hot water is greater than the tank storage.	Determine peak usage and compare to tank volume.
	Sediment and/or scale buildup	Contact qualified contractor to clean coil.
	Faulty water heater thermostat	Replace thermostat
Water at faucet too hot	Thermostat set to high	Lower thermostat setting.
	Improper wiring or plumbing.	Compare to installation guide.
Boiler cycles more than 5 times per day in summer	Excessive demand	Reduce demand or consider larger boiler and/or water heater.
	Faulty thermostat	Replace thermostat
	Boiler high limit set to low	Increase boiler hi-limit setting
	Sediment and or scale buildup	Contact qualified contractor to clean coil.

180 deg. F Boiler Supply IBR Rating Condition

MODEL	30 and 40LOW				40				60							
	Boiler flow = 14 gpm								Boiler flow = 14 gpm							
BOILER	1st HOUR		CONTINUOUS		1st HOUR		CONTINUOUS		1st HOUR		CONTINUOUS					
OUTPUT (BTU/HR)	RATING (GAL/HR)		RATING (GAL/HR)		RATING (GAL/HR)		RATING (GAL/HR)		RATING (GAL/HR)		RATING (GAL/HR)					
	140 F	115 F	140 F	115 F	140 F	115 F	140 F	115 F	140 F	115 F	140 F	115 F				
50,000	94	119	67	92	103	128	67	92	121	146	67	92				
60,000	107	138	80	111	116	147	80	111	134	165	80	111				
80,000	134	174	107	147	143	183	107	147	161	201	107	147				
100,000	160	212	133	185	169	220	133	184	187	238	133	184				
120,000	171	227	144	200	190	250	154	214	214	275	160	221				
140,000	171	227	144	200	190	250	154	214	227	293	173	239				
160,000	171	227	144	200	190	250	154	214	227	293	173	239				
MODEL	60 LOW				80				115							
	Boiler flow = 14 gpm								Boiler flow = 14 gpm							
BOILER	1st HOUR		CONTINUOUS		1st HOUR		CONTINUOUS		1st HOUR		CONTINUOUS					
OUTPUT (BTU/HR)	RATING (GAL/HR)		RATING (GAL/HR)		RATING (GAL/HR)		RATING (GAL/HR)		RATING (GAL/HR)		RATING (GAL/HR)					
	140 F	115 F	140 F	115 F	140 F	115 F	140 F	115 F	140 F	115 F	140 F	115 F				
50,000	121	146	67	92	139	164	67	92	170	195	67	92				
60,000	134	165	80	111	152	183	80	111	183	214	80	111				
80,000	161	201	107	147	179	219	107	147	210	250	107	147				
100,000	187	238	133	184	205	256	133	184	236	287	133	184				
120,000	208	268	154	214	232	293	160	221	263	324	160	221				
140,000	208	268	154	214	239	303	167	231	289	360	186	257				
160,000	208	268	154	214	239	303	167	231	289	360	186	257				
High Output Units - 80-HO and 115-HO - 21 gpm boiler flow																
MODEL	80-HO High Output				115-HO High Output											
	Boiler flow = 21 gpm								Boiler flow = 21 gpm							
BOILER	1st HOUR		CONTINUOUS		1st HOUR		CONTINUOUS		1st HOUR		CONTINUOUS					
OUTPUT (BTU/HR)	RATING (GAL/HR)		RATING (GAL/HR)		RATING (GAL/HR)		RATING (GAL/HR)		RATING (GAL/HR)		RATING (GAL/HR)					
	140 F	115 F	140 F	115 F	140 F	115 F	140 F	115 F	140 F	115 F	140 F	115 F				
50,000	139	164	67	92	170	195	67	92								
60,000	152	183	80	111	183	214	80	111								
80,000	179	219	107	147	210	250	107	147								
100,000	205	256	133	184	236	287	133	184								
120,000	232	293	160	221	263	324	160	221								
140,000	258	330	186	258	289	361	186	258								
160,000	285	368	213	296	316	398	213	295								
180,000	312	405	240	333	343	435	240	332								
200,000	339	442	267	370	370	473	267	370								
220,000	343	473	271	401	396	509	293	406								
240,000	362	473	290	401	412	531	309	428								
250,000	362	473	290	401	412	531	309	428								

200 deg. F Boiler Supply

MODEL	30 and 40LOW				40				60			
	Boiler flow = 10 gpm				Boiler flow = 10 gpm				Boiler flow = 10 gpm			
BOILER OUTPUT (BTU/HR)	1st HOUR RATING (GAL/HR)		CONTINUOUS RATING (GAL/HR)		1st HOUR RATING (GAL/HR)		CONTINUOUS RATING (GAL/HR)		1st HOUR RATING (GAL/HR)		CONTINUOUS RATING (GAL/HR)	
	140 F	115 F	140 F	115 F	140 F	115 F	140 F	115 F	140 F	115 F	140 F	115 F
50,000	94	119	67	92	103	128	67	92	121	146	67	92
60,000	107	138	80	111	116	147	80	111	134	165	80	111
80,000	134	174	107	147	143	183	107	147	161	201	107	147
100,000	160	211	133	184	169	220	133	184	187	238	133	184
120,000	183	242	156	215	196	257	160	221	214	275	160	221
140,000	183	242	156	215	202	266	166	230	239	312	185	258
160,000	183	242	156	215	202	266	166	230	239	312	185	258
MODEL	60 LOW				80				115			
	Boiler flow = 10 gpm				Boiler flow = 12 gpm				Boiler flow = 12 gpm			
BOILER OUTPUT (BTU/HR)	1st HOUR RATING (GAL/HR)		CONTINUOUS RATING (GAL/HR)		1st HOUR RATING (GAL/HR)		CONTINUOUS RATING (GAL/HR)		1st HOUR RATING (GAL/HR)		CONTINUOUS RATING (GAL/HR)	
	140 F	115 F	140 F	115 F	140 F	115 F	140 F	115 F	140 F	115 F	140 F	115 F
50,000	121	146	67	92	139	164	67	92	170	195	67	92
60,000	134	165	80	111	152	183	80	111	183	214	80	111
80,000	161	201	107	147	179	219	107	147	210	250	107	147
100,000	187	238	133	184	205	256	133	184	236	287	133	184
120,000	197	275	160	221	232	293	160	221	263	324	160	221
140,000	197	284	166	230	257	328	185	256	289	361	186	258
160,000	197	284	166	230	257	328	185	256	309	388	206	285
High Output Units - 80-HO and 115-HO - 15 gpm boiler flow												
MODEL	80-HO High Output				115-HO High Output							
	Boiler flow = 15 gpm				Boiler flow = 15 gpm							
BOILER OUTPUT (BTU/HR)	1st HOUR RATING (GAL/HR)		CONTINUOUS RATING (GAL/HR)		1st HOUR RATING (GAL/HR)		CONTINUOUS RATING (GAL/HR)					
	140 F	115 F	140 F	115 F	140 F	115 F	140 F	115 F				
50,000	139	164	67	92	170	195	67	92				
60,000	152	183	80	111	183	214	80	111				
80,000	179	219	107	147	210	250	107	147				
100,000	205	256	133	184	236	287	133	184				
120,000	232	293	160	221	263	324	160	221				
140,000	258	330	186	258	289	361	186	258				
160,000	285	368	213	296	316	398	213	295				
180,000	312	405	240	333	343	435	240	332				
200,000	339	442	267	370	370	473	267	370				
220,000	365	478	293	406	396	509	293	406				
240,000	386	507	314	435	423	546	320	443				
250,000	386	507	314	435	436	564	333	461				

REPLACEMENT PARTS

Part	Part No.	Description
T+P Relief Valve	TP-3	150 psi / 210deg. F, 4" probe, ANSI/AGA Cert.
Thermostat	L4080	Honeywell L4080B
Thermostat Well	R-Well	3" Immersion Well, 3/4", 1/2" NPT

ECR International, Inc.

LIMITED WARRANTY

INDIRECT WATER HEATERS & STORAGE TANKS

By this Limited Warranty ECR International, Inc. ("ECR") issues limited warranties from the date of original installation of the H₂O Indirect Water Heater or Storage Tank ("Product") to the person that purchased the new Product directly (a) from the ECR brand dealer; or (b) in the case of a newly constructed home, from the contractor who purchased such new Product directly from an ECR brand dealer or wholesaler for installation and use in the newly constructed home (such person in either case referred to hereinafter as the "Original Purchaser"), subject to the terms and conditions set forth below.

WARRANTY COVERAGE FOR RESIDENTIAL USAGE

The following limited warranty set forth in this section shall apply to only the original installation of the Product in a single-family dwelling used without interruption by the Original Purchaser as his or her primary residence ("Residential Application"). "Residential Application" shall also mean usage in a multiple family dwelling provided that the Product services only one (1) dwelling in such multiple family dwelling. The term "Residential Application" shall not include any usage of the Product above one hundred fifty (150) degrees Fahrenheit.

First Year

ECR warrants its Product used in Residential Applications to be free from defects in material and workmanship under normal usage and service for a period of one (1) year from the date of original installation. In the event that any component of the Product is found to be defective in material or workmanship during this one-year period, then ECR will repair or replace, at its option, the defective component.

Second Year through Lifetime

During the remaining lifetime of the Product, ECR will repair or replace, at its option, any component of the Product found to have a defect or malfunction that results in a water leak from the outer jacket, inner tank, or heat exchanger of the Product under normal usage and service.

If ECR is unable to repair or replace the Product component so as to repair the water leak from the outer jacket, inner tank, or heat exchanger of the Product, after a reasonable number of attempts, then ECR will provide at its option, either a replacement Product, or a full refund of the purchase price.

If at the time of the request for service, the Original Purchaser cannot provide a copy of the original sales receipt for the Product, or equivalent document, then the warranty period for the Product shall be ten (10) years from the date of manufacture of the Product.

WARRANTY COVERAGE FOR COMMERCIAL USAGE

The following limited warranty set forth in this section shall apply to only the original installation of the Product in a Commercial Application, used without interruption by the Original Purchaser. "Commercial Application" as used herein shall mean, any usage not falling within the above definition of Residential Application. The term "Commercial Application" shall include any usage of the Product above one hundred fifty (150) degrees Fahrenheit.

First Year

ECR warrants its Product used in Commercial Applications to be free from defects in material and workmanship under normal usage and service for a period of one (1) year from the date of original installation. In the event that any component of the Product is found to be defective in material or workmanship during this one-year period, then ECR will repair or replace, at its option, the defective component.

Second Year through Fifth Year

During the second through fifth year after the date of original installation, ECR will repair or replace, at its option, any component of the Product having a defect or malfunction that results in a water leak from the outer jacket, inner tank, and heat exchanger of the Product under normal usage and service.

If ECR is unable to repair or replace the Product component so as to repair the water leak from the outer jacket, inner tank, or heat exchanger of the Product, after a reasonable number of attempts, then ECR will provide at its option, either a replacement Product, or a full refund of the purchase price.

LIMITATIONS AND EXCLUSIONS

1. Under no circumstances will ECR be responsible for any other costs associated with rectifying the defective part or Product, including, without limitation, costs associated with removing and reinstalling the defective part or Product and/or its replacement part or Product, and all labor and material costs connected therewith, including, without limitation, costs associated with returning the defective part or Product to ECR.

2. This Limited Warranty will not be applicable if the Product is (a) used or operated at a pressure over or under its rated capacity; (b) installed for uses other than home heating; (c) not maintained in accordance with ECR's recommendation or accepted good practice as determined by industry standards; or (d) subjected to unauthorized alteration.

3. This Limited Warranty will not be applicable if the Product has been damaged as a result of being improperly installed, serviced or operated, including, without limitation, operated with insufficient water, allowed to freeze or subjected to flood conditions.

4. In order for this Limited Warranty to be effective (a) the Product must have been assembled in strict compliance with installation instructions furnished with the Product; and (b) the Product sections must not have been damaged during shipment and installation.

5. ECR shall not be liable for any damages, defaults or delays in performance under this Limited Warranty caused by (a) any contingency beyond its control, including, without limitation, a shortage or reduced supply of energy or raw materials, freezing, flood, fire, wind or lightning; (b) the failure of external wiring, piping, or other attachments and accessory products not integral with the Product; (c) installation, service or operation that is not in compliance with all applicable federal, state and provincial laws or regulations; (d) misapplication or the use of the Product for purposes other than for which it was designed; (e) the use of parts not supplied or designated by ECR; (f) failure to maintain the Product free of water sediments or scale deposits; (g) components of a Product which are not defective, but must be replaced during the warranty period as a result of reasonable wear and tear; (h) failure of a component, control or component part other than a component part manufactured solely by ECR; or (i) potable water with a Ph exceeding 8.0 or below 6.0, and/or chloride concentrations exceeding 80 parts per million (ppm).

6. This Limited Warranty in no way can be considered as a guarantee of workmanship of an installer or repairman connected with the installation or repair of the Product or as imposing on ECR liability of any nature for unsatisfactory performance as a result of faulty workmanship in the installation or service of the Product, which liability is hereby expressly disclaimed.

7. The furnishing of replacement parts under the terms of this Limited Warranty will apply to the original warranty period and will not serve to extend such period.

8. This Limited Warranty only applies to Products installed in the United States or Canada.

9. The remedy for breach of this Limited Warranty is expressly limited to the repair or replacement of any part found to be defective under conditions of normal use, unless otherwise specifically set forth herein, and the remedy for breach of this Limited Warranty, statutory duty or by reason of tort (including, without limitation, negligence) does not extend to liability for incidental, special or consequential damages or losses, such as loss for the use of the material, inconvenience or loss of time. The maximum liability of ECR in connection with the sale of the Product shall not in any case exceed the price of the part claimed to be defective, or the price of the Product if the entire Product is claimed to be defective. This Limited Warranty is the complete and exclusive statement of warranty terms in regards to the Product.

10. FOR ALL SALES NOT SUBJECT TO THE MAGNUSON-MOSS WARRANTY ACT THE FOREGOING WARRANTIES ARE EXCLUSIVE AND ARE GIVEN AND ACCEPTED IN LIEU OF ANY AND ALL OTHER WARRANTIES, EXPRESS OR IMPLIED, INCLUDING, WITHOUT LIMITATION, THE IMPLIED WARRANTIES OF MERCHANTABILITY AND FITNESS FOR PARTICULAR PURPOSE. FOR ALL OTHER SALES, ALL IMPLIED WARRANTIES OF MERCHANTABILITY AND/OR FITNESS FOR ANY PARTICULAR PURPOSE ARE LIMITED IN DURATION TO THE PERIOD OF THIS LIMITED WARRANTY.

PLEASE NOTE: Some states, provinces and territories do not allow the exclusion or limitation of incidental or consequential damages, or limitations on how long an implied warranty lasts, so the above limitations and exclusions may not apply to you.

MISCELLANEOUS

1. The Magnuson-Moss Warranty Act applies to "consumer" sales as contrasted with "commercial" sales. A consumer sale is one to a buyer for personal, family or household purposes and not for the purpose of resale.

2. If any provision of this Limited Warranty shall be determined to be illegal, unconscionable or unenforceable, all other terms and provisions hereof shall nevertheless remain effective and shall be enforced to the fullest extent permitted by law. The warranties made under this Limited Warranty are exclusive and may not be altered, enlarged or changed by a distributor, dealer, or other person whatsoever, other than pursuant to a written agreement executed by a duly authorized officer of ECR.

3. This Limited Warranty is nontransferable and shall be for the benefit of the Original Purchaser of the Product only.

4. This Limited Warranty gives the Original Purchaser only specific legal rights and you may have other legal rights which vary from state-to-state.

PROCEDURE FOR OBTAINING WARRANTY SERVICE

1. At the time a claim is filed under this Limited Warranty the Original Purchaser must present a copy of the original sales receipt, and a deed, utility bill, or equivalent document evidencing both ownership of the Product and installation in the dwelling or commercial property owned by the Original Purchaser. With regard to claims made by an Original Purchaser used in a Commercial Application, in no event shall notification of a service request be received later than five (5) years from the date of original installation.

2. For prompt warranty service, notify the installer who, in turn, will notify the ECR distributor from whom such distributor purchased the Product. If this action does not result in warranty service, the Original Purchaser or installer should contact ECR Customer Service (see contact information below), giving full particulars in support of the claim. Alleged defective part or parts must be returned through trade channels in accordance with ECR's procedure currently in force for handling returned goods for the purpose of inspection or determining the cause of failure. ECR will furnish the new part(s) to an authorized ECR distributor who, in turn, will furnish the part(s) to the heating contractor who installed the Product.

ECR International, Inc.
2201 Dwyer Avenue
Utica, New York 13504-4729
Ph: 315/797-1310
Customer Service Fax: 315/724-9319
E-Mail: info@ecrinternational.com

PN 240009217 Rev. A 10/11

NOTES

NOTES

H₂O



ECR International, Inc
2201 Dwyer Avenue, Utica NY 13504-4729

web site: www.ecrinternational.com