

MODELS

H₂O40BT

H₂O60BT

H₂O80BT

H₂OBT40114

H₂OBT40112

H₂OBT402

H₂OBT60114

H₂OBT602

H₂OBT80114

H₂OBT80112

H₂OBT802

H₂OBT115114

H₂OBT115112

H₂OBT1152

H₂O

Hydronic Buffer Tanks

INSTALLATION, OPERATION & MAINTENANCE MANUAL

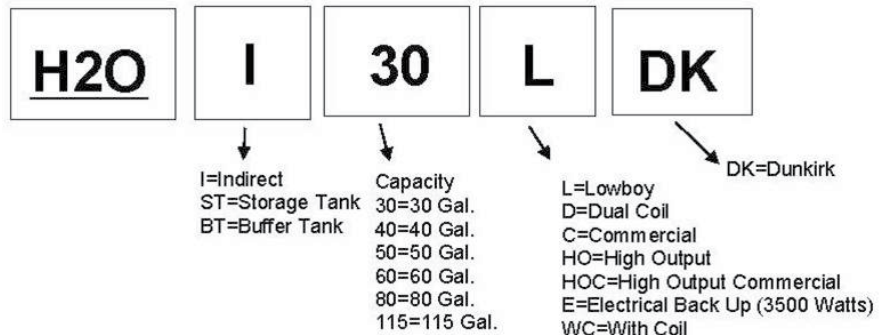

Intertek

Conforms to UL STD 174

Certified to CAN/CSA STD C22.2 No. 110-94

Information and specifications outlined in this manual in effect at the time of printing of this manual. ECR International reserves the right to discontinue, change specifications or system design at any time without notice and without incurring any obligation, whatsoever.



An ISO 9001-2008 Certified Company

ECR International, Inc.

2201 Dwyer Avenue, Utica NY 13501

web site: www.ecrinternational.com

P/N# 61500057, Rev. A [10/2011]

Table of Contents

I. General Information & Safety Instructions	2
II. Important Safety Instructions	3
III. Application	3

I. General Information

IMPORTANT INFORMATION – READ CAREFULLY

NOTE: The equipment shall be installed in accordance with those installation regulations required in the area where the installation is to be made. These regulations shall be carefully followed in all cases. Authorities having jurisdiction shall be consulted before installations are made.

All wiring on water heaters shall be in accordance with the National Electrical Code and/or local regulations.

WARNING

Improper installation, adjustment, alteration, service or maintenance can cause property damage, personal injury, or loss of life. Read and understand the entire manual before attempting installation, start-up, operation, or service. Installation and service must be performed only by an experienced, skilled installer or service agency.

This water heater contains very hot water under high pressure. Do not unscrew any pipe fittings or attempt to disconnect any components of this water heater without positively assuring that the water is cool and has no pressure. Always wear protective clothing and equipment when installing, starting up or servicing this water heater to prevent scalding injuries. Do not rely on the pressure and temperature gauges to determine the temperature and pressure of the water heater. This water heater contains components that become very hot when the boiler is operating. Do not touch any components unless they are cool.

Failure to follow all instructions in the proper order can cause personal injury or death. Read all instructions, including all those contained in component manufacturers' manuals before installing, starting up, operating, maintaining, or servicing the water heater.

CAUTION

To reduce the risk of excessive pressures and temperatures in this water heater, install temperature and pressure protective equipment required by local codes but no less than a combination temperature relief valve certified by a nationally recognized testing laboratory that maintains periodic inspection of production of listed equipment or materials, as meeting the requirements for Relief Valves and Automatic Shutoff Devices for Hot Water Supply Systems, ANSI Z21.22- latest edition. This valve must be marked with a maximum set pressure not to exceed the marked working pressure of the water heater. Install the valve into an opening provide and marked for this purpose in the water heater, and orient it or provide tubing so that any discharge from the valve will exit only within 6 inches above, or at any distance below, the structural floor, and cannot contact any live electrical part. The discharge opening must not be blocked or reduced in size under any circumstances.

The heat transfer medium must be water or other non-toxic fluid having a toxicity rating or class of 1, as listed in clinical Toxicology of Commercial Products, latest edition.

The pressure of the heat transfer medium must be limited to a maximum of 60 psig by an approved safety or relief valve.

⚠ DANGER

DO NOT store or use gasoline or other flammable vapors or liquids in the vicinity of this or any other appliance.

If you smell gas vapors, DO NOT try to operate any appliance - DO NOT touch any electrical switch or use any phone in the building. Immediately, call the gas supplier from a remote located phone. Follow the gas supplier's instructions or if the supplier is unavailable, contact the fire department.

II. IMPORTANT SAFETY INSTRUCTIONS

WARNING – When using electrical appliances, basic safety precautions to reduce the risk of fire, electric shock, or injury to persons should be followed, including:

READ ALL INSTRUCTIONS BEFORE USING THIS BUFFER TANK.

1. This tank must be grounded if any electrical control is used. Connect only to properly grounded outlet.
2. Install or locate this buffer tank only in accordance with the provided installation instructions
3. Use this tank only for its intended use as described in this manual.
4. As with any appliance, close supervision is necessary when used by children.
5. This tank should be serviced only by qualified personnel. Contact nearest authorized service facility for examination, repair, or adjustment.

SAVE THESE INSTRUCTIONS

III. Application

The primary application of a buffer tank is to reduce heat pump, chiller, or boiler short cycling. Hydronic buffer tanks are used in systems operating below the design load condition, which is most of the time, or in systems having several low BTU cooling or heating loads calling at different times. This can cause the heat pump or the boiler to short cycle, resulting in reduced operating efficiency and shorter equipment life.

The hydronic buffer tanks are built with 4 connections. Two connections can be piped to the heat pump or boiler, and two connections can be piped to the distribution system. If piped correctly, the tank can serve as both a thermal buffer and a hydraulic separator. The heat pump or boiler can be hydraulically decoupled from the distribution system. The tanks are all stainless steel construction with R-12 insulation, and an ABS jacket.

A 3/8" ID thermal well is located mid-tank. Thermistors to be inserted 3" into the well, or the well will accept the Honeywell L4006A controls.

WARNING:

Do not operate the water heaters in areas where the Ph is above 8.0 or below 6.0, and/or with chloride concentrations greater than 100 parts per million (ppm). ECR's standard warranty does not cover problems caused by improper water Ph or excessive levels of chlorides.

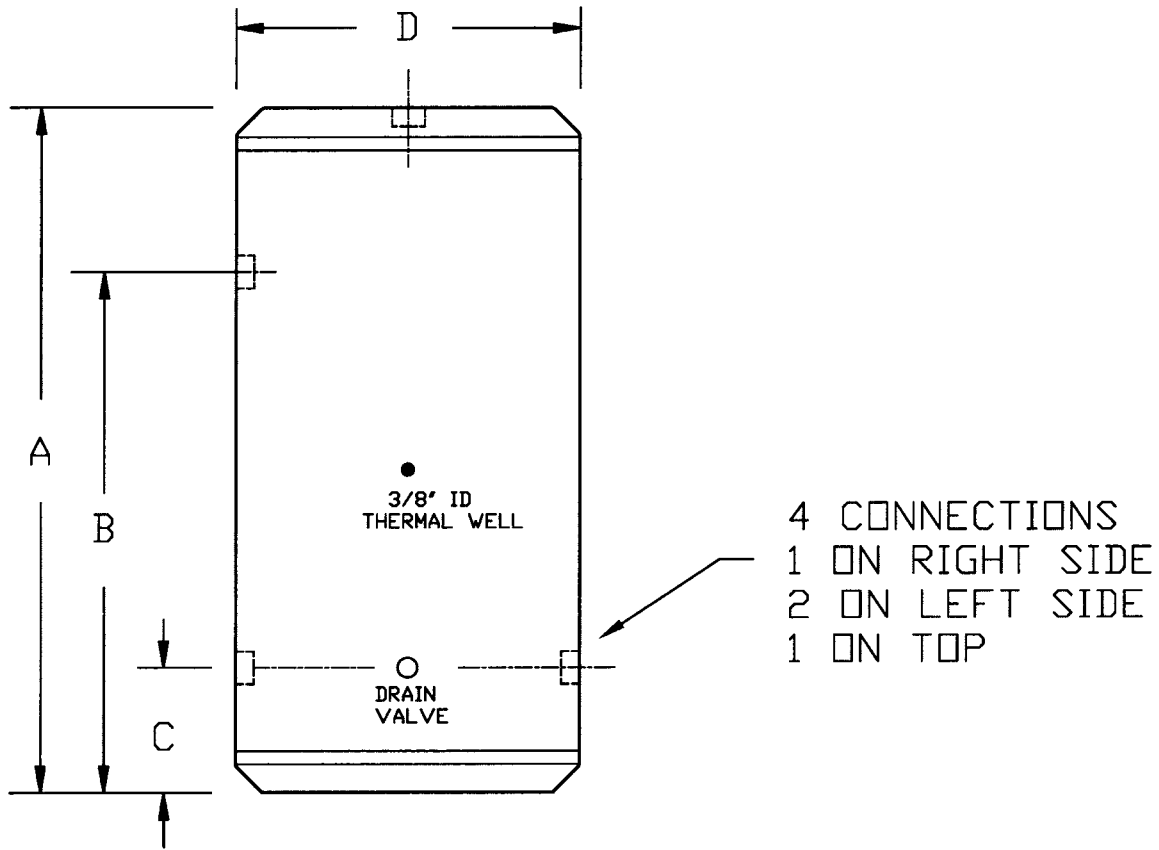

Model	Volume (gal.)	A Height	B	C	D Diameter	Connections (NPT)	Max. Working Pressure (psi)	Approx. Ship wt. (lbs.)
H2O40BTXXX	40	42.0	29.0	9.0	22.5	Specify	60	87
H2O60BTXXX	60	42.0	29.5	9.5	26.5	1¼", 1½"	60	115
H2O80BTXXX	80	52.0	39.5	9.5	26.5	or 2" NPT	60	125

XXX = Refer to Models to specify tapping sizes.

The buffer tanks are all stainless steel construction, insulated with a thermoplastic jacket.

WARNING: DO NOT use in potable water systems.

WARNING: Use this vessel only in hydronic heating systems. The installer must comply with all plumbing codes. Do not operate above the temperature or pressure specified on the rating plate. Failure to comply may result in personal injury, property damage, or death.

An example of piping a buffer tank follows showing a water source heat pump application. In all applications note that the tank top fitting should be piped the distribution supply line to the air purger and vent. This way the tank will be self venting and no additional air vent is needed to install or maintain.

The objective in any application is to pipe the buffer tank such that the heating or cooling source is hydraulically decoupled from the distribution system.

Buffer Tank Sizing - Calculating Capacity

The buffer tanks are a simple, cost effective way to improve overall system efficiency by reducing unnecessary equipment short cycling. The recommended capacity or volume of a buffer tank is based on four variables.

1. The duration of the heating or cooling source "on time". (minutes)
The desired length of "on time" for each run cycle depends on the type of equipment used. Heat pump and chiller manufacturers typically recommend a minimum of 5 to 10 minutes on time, and boiler manufacturers may recommend a minimum of 10 minutes "on time". Check with your equipment manufacturer. Generally, the longer the "on time", the higher the overall operating efficiency.
2. The minimum rate of heat input. (BTU/HR)
This is based on the heat pump or chiller output, or the boiler output at the minimum firing rate if the boiler has a variable input system that ramps input down as the demand decreases.
3. The minimum system load (BTU/HR)
This is the demand placed on the system with the smallest zone calling for heat.
4. The allowable tank temperature rise. (deg. F)
This varies depending on the type of heating or cooling system used, and on the design of the distribution system. Chillers may require a tight, (6 deg. F), differential to assure good dehumidification and prevent freezing, heat pumps may require a 10 deg. F differential to maintain a high COP, and boilers with hydronic heating distribution systems may require a differential anywhere between 10 to 40 deg. F depending on the application.

The following formula determines the tank volume:

$$V = \frac{T \times (Q \text{ heat input} - Q \text{ min. heat load})}{\text{Tank temp. rise} \times 500}$$

V = Buffer tank volume (gallons)

T = desired heat source "on cycle" (min.)

Q heat source = heat source output (BTU/HR)

Q min. heat load = heat output to minimum load

Tank temp rise (deg.F)

Water to Water Heat Pump Example: Town and Country Mechanical wants a minimum heat pump on time of 10 minutes. The heat pump output is 46,500 BTU/HR. The smallest zone is 7,000 BTU/HR bathroom. The allowable temperature differential is 90 to 100 deg. F for the radiant heat zones.

$$V = \frac{10 \times (46,500 - 7,000)}{(100-90) \times 500} = 79.0 \text{ Gallons minimum volume. Choose the HF-80BT buffer tank.}$$

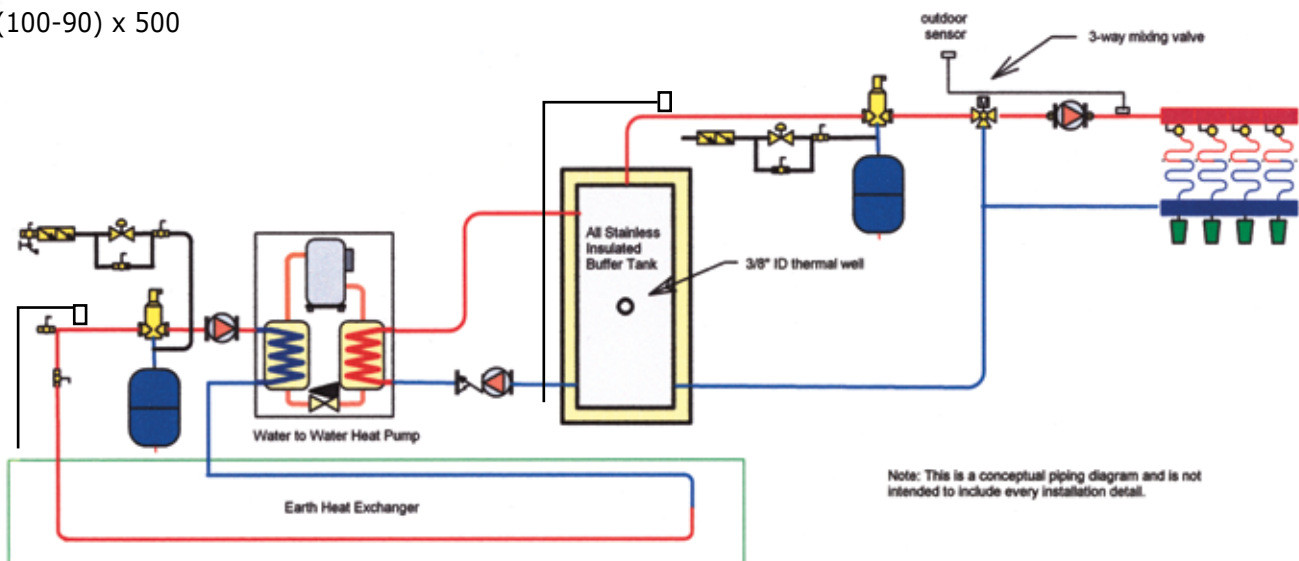

Note: This is a conceptual piping diagram and is not intended to include every installation detail.

Hydronic Buffer Tank applied to Water source heat pump application

ECR International, Inc.

LIMITED WARRANTY

HYDRONIC BUFFER TANKS & SOLAR HOT WATER STORAGE TANKS

By this Limited Warranty ECR International, Inc. ("ECR") issues limited warranties from the date of original installation of the Hydronic Buffer Tank or Solar Hot Water Storage Tank ("Product") to the person that purchased the new Product directly (a) from the ECR brand dealer; or (b) in the case of a newly constructed home, from the contractor who purchased such new Product directly from an ECR brand dealer or wholesaler for installation and use in the newly constructed home (such person in either case referred to hereinafter as the "Original Purchaser"), subject to the terms and conditions set forth below.

WARRANTY COVERAGE FOR RESIDENTIAL USAGE

The following limited warranty set forth in this section shall apply to only the original installation of the Product in a single-family dwelling used without interruption by the Original Purchaser as his or her primary residence ("Residential Application"). "Residential Application" shall also mean usage in a multiple family dwelling provided that the Product services only one (1) dwelling in such multiple family dwelling.

I. LIMITED ONE YEAR WARRANTY

ECR warrants its Product used in Residential Applications to be free from defects in material and workmanship under normal usage and service for a period of one (1) year from the date of original installation. In the event that the Product is found to be defective in material or workmanship during this one-year period, then ECR will repair or replace, at its option, the defective Product.

II. LIMITED WARRANTY ON STORAGE TANK/HEAT EXCHANGER ASSEMBLY

ECR warrants that the Product's storage tank/heat exchanger assembly shall be free from leaks during normal usage and service for a period of fifteen (15) years from the date of original installation. In the event that a leak should develop and occur within this limited warranty period as a result of defective material or workmanship, ECR will replace the Product. During the five (5) year period from the date of original installation ECR's replacement of the defective Product shall be without charge. From the sixth (6th) year from the date of original installation to the fifteenth (15th) year from the date of original installation, ECR's replacement of the defective Product shall be made upon payment by the Original Purchaser to ECR of a proportionate charge based upon the time the Product has been in service.

The proportionate charge will be equal to the appropriate percentage of the list price of such Product at the time the warranty claim is made and will be determined as follows:

- Within the sixth (6th) year through the seventh (7th) year from the original date of installation – sixty percent (60%)
- Within the eighth (8th) year through the ninth (9th) year from the original date of installation – sixty-five percent (65%)
- Within the tenth (10th) year through the eleventh (11th) year from the original date of installation – seventy percent (70%)
- Within the twelfth (12th) year through the thirteenth (13th) year from the original date of installation – seventy-five percent (75%)
- Within the fourteenth (14th) year through the fifteenth (15th) year from the original date of installation – eighty percent (80%)

Please Note: If the Product model involved is no longer available due to product obsolescence or redesign, the value used to establish the list price will be the current retail price of the nearest equivalent Product.

LIMITATIONS AND EXCLUSIONS

1. Under no circumstances will ECR be responsible for any other costs associated with rectifying the defective part or Product, including, without limitation, costs associated with removing and reinstalling the defective part or Product and/or its replacement part or Product, and all labor and material costs connected therewith, including, without limitation, costs associated with returning the defective part or Product to ECR.
2. This Limited Warranty will not be applicable if the Product is (a) used or operated at a pressure over or under its rated capacity; (b) installed for uses other than home heating; (c) not maintained in accordance with ECR's recommendation or accepted good practice as determined by industry standards; or (d) subjected to unauthorized alteration.
3. This Limited Warranty will not be applicable if the Product has been damaged as a result of being improperly installed, serviced or operated, including, without limitation, operated with insufficient water, allowed to freeze or subjected to flood conditions.
4. In order for this Limited Warranty to be effective (a) the Product must have been assembled in strict compliance with installation instructions furnished with the Product; and (b) the Product sections must not have been damaged during shipment and installation.
5. ECR shall not be liable for any damages, defaults or delays in performance under this Limited Warranty caused by (a) any contingency beyond its control, including, without limitation, a shortage or reduced supply of energy or raw materials, freezing, flood, fire, wind or lightning; (b) the failure of external wiring, piping, or other attachments and accessory products not integral with the Product; (c) installation, service or operation that is not in compliance with all applicable federal, state and provincial laws or regulations; (d) misapplication or the use of the Product for purposes other than for which it was designed; (e) the use of parts not supplied or designated by ECR; (f) failure to maintain the Product free of water sediments or scale deposits; (g) components of a Product which are not defective, but must be replaced during the warranty period as a result of reasonable wear and tear; (h) failure of a component, control or component part other than a component part manufactured solely by ECR; or (i) potable water with a Ph exceeding 8.0 or below 6.0, and/or chloride concentrations exceeding 80 parts per million (ppm).

6. This Limited Warranty in no way can be considered as a guarantee of workmanship of an installer or repairman connected with the installation or repair of the Product or as imposing on ECR liability of any nature for unsatisfactory performance as a result of faulty workmanship in the installation or service of the Product, which liability is hereby expressly disclaimed.

7. The furnishing of replacement parts under the terms of this Limited Warranty will apply to the original warranty period and will not serve to extend such period.

8. This Limited Warranty only applies to Products installed in the United States or Canada.

9. The remedy for breach of this Limited Warranty is expressly limited to the repair or replacement of any part found to be defective under conditions of normal use, unless otherwise specifically set forth herein, and the remedy for breach of this Limited Warranty, statutory duty or by reason of tort (including, without limitation, negligence) does not extend to liability for incidental, special or consequential damages or losses, such as loss for the use of the material, inconvenience or loss of time. The maximum liability of ECR in connection with the sale of the Product shall not in any case exceed the price of the part claimed to be defective, or the price of the Product if the entire Product is claimed to be defective. This Limited Warranty is the complete and exclusive statement of warranty terms in regards to the Product.

10. FOR ALL SALES NOT SUBJECT TO THE MAGNUSON-MOSS WARRANTY ACT THE FOREGOING WARRANTIES ARE EXCLUSIVE AND ARE GIVEN AND ACCEPTED IN LIEU OF ANY AND ALL OTHER WARRANTIES, EXPRESS OR IMPLIED, INCLUDING, WITHOUT LIMITATION, THE IMPLIED WARRANTIES OF MERCHANTABILITY AND FITNESS FOR PARTICULAR PURPOSE. FOR ALL OTHER SALES, ALL IMPLIED WARRANTIES OF MERCHANTABILITY AND/OR FITNESS FOR ANY PARTICULAR PURPOSE ARE LIMITED IN DURATION TO THE PERIOD OF THIS LIMITED WARRANTY.

PLEASE NOTE: Some states, provinces and territories do not allow the exclusion or limitation of incidental or consequential damages, or limitations on how long an implied warranty lasts, so the above limitations and exclusions may not apply to you.

MISCELLANEOUS

1. The Magnuson-Moss Warranty Act applies to “consumer” sales as contrasted with “commercial” sales. A consumer sale is one to a buyer for personal, family or household purposes and not for the purpose of resale.

2. If any provision of this Limited Warranty shall be determined to be illegal, unconscionable or unenforceable, all other terms and provisions hereof shall nevertheless remain effective and shall be enforced to the fullest extent permitted by law. The warranties made under this Limited Warranty are exclusive and may not be altered, enlarged or changed by a distributor, dealer, or other person whatsoever, other than pursuant to a written agreement executed by a duly authorized officer of ECR.

3. This Limited Warranty is nontransferable and shall be for the benefit of the Original Purchaser of the Product only.

4. This Limited Warranty gives the Original Purchaser only specific legal rights and you may have other legal rights which vary from state-to-state.

PROCEDURE FOR OBTAINING WARRANTY SERVICE

1. At the time a claim is filed under this Limited Warranty the Original Purchaser must present a copy of the original sales receipt, and a deed, utility bill, or equivalent document evidencing both ownership of the Product and installation in the dwelling owned by the Original Purchaser.

2. For prompt warranty service, notify the installer who, in turn, will notify the ECR distributor from whom such distributor purchased the Product. If this action does not result in warranty service, the Original Purchaser or installer should contact ECR Customer Service (see contact information below), giving full particulars in support of the claim. Alleged defective part or parts must be returned through trade channels in accordance with ECR’s procedure currently in force for handling returned goods for the purpose of inspection or determining the cause of failure. ECR will furnish the new part(s) to an authorized ECR distributor who, in turn, will furnish the part(s) to the heating contractor who installed the Product.

ECR International, Inc.
2201 Dwyer Avenue
Utica, New York 13504-4729
Ph: 315/797-1310
Customer Service Fax: 315/724-9319
E-Mail: info@ecrinternational.com

PN 240009218 Rev. A 10/11

REPLACEMENT PARTS

Part	Part No.	Description
T+P Relief Valve	TP-3	150 psi / 210deg. F, 4” probe, ANSI/AGA Cert.
Thermostat	L4080	Honeywell L4080B
Thermostat Well	R-Well	3” Immersion Well, 3/4”, 1/2” NPT

H₂O



ECR International, Inc
2201 Dwyer Avenue, Utica NY 13504-4729

web site: www.ecrinternational.com