

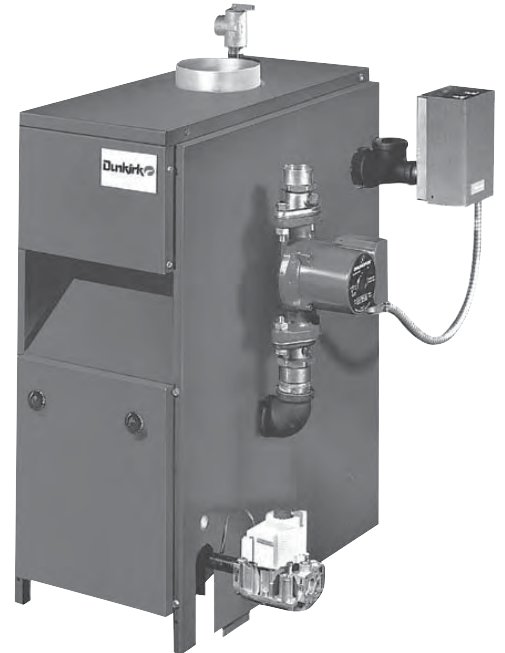

# PWB SERIES GAS-FIRED HOT WATER BOILERS

**MODEL PVWB**  
Continuous Pilot



**MODEL PWB**  
Electronic  
Intermittent Ignition

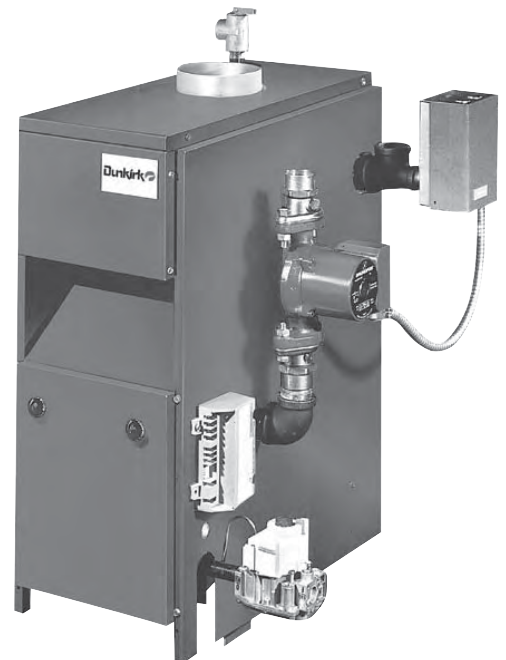

An ISO 9001-2008 Certified Company

**ECR International, Inc.**  
2201 Dwyer Avenue,  
Utica NY 13501  
[www.ecrinternational.com](http://www.ecrinternational.com)

P/N 14683002, Rev. A [8/2011]

## BOILER RATINGS AND CAPACITIES

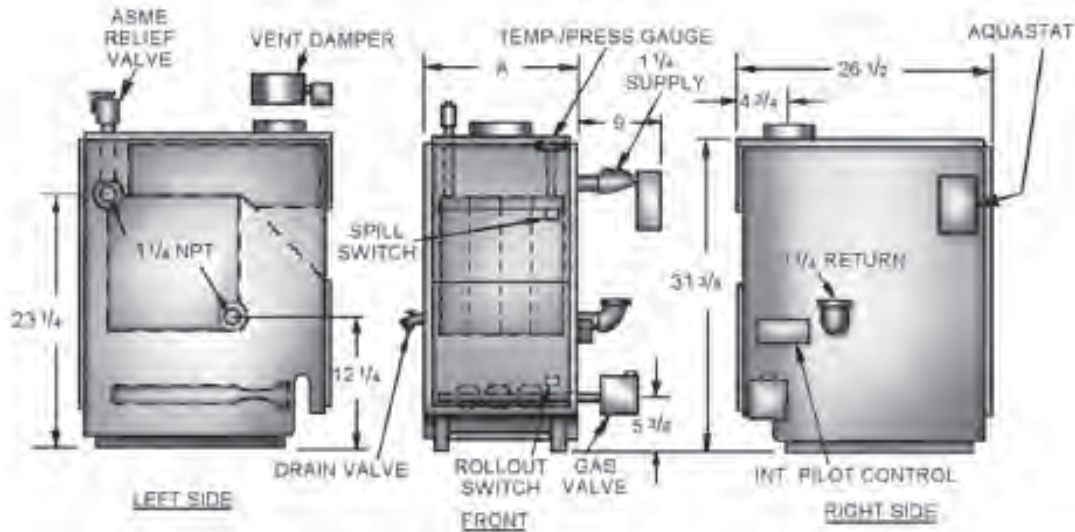

### NATURAL AND PROPANE GAS RATINGS

BASIC BOILER UNIT NO.		Number of Sections	Input MBH <sup>(1,2)</sup>	Heating Capacity MBH <sup>(1,3)</sup>	Net I=B=R Rating MBH <sup>(1,4)</sup>	Dimensions (Inches)	
Electronic Ignition With Vent Damper	Continuous Pilot With Vent Damper					Flue Diameter	"A" Width
PWB-2D	PVWB-2D	2	37.5	30	26	3 3/4	8
PWB-3D	PVWB-3D	3	70	57	50	5	11 1/4
PWB-4D	PVWB-4D	4	105	85	74	6	14 1/2
PWB-5D	PVWB-5D	5	140	113	98	6	17 3/4
PWB-6D	PVWB-6D	6	175	142	123	7	21
PWB-7D	PVWB-7D	7	210	170	148	7	24 1/4
PWB-8D	PVWB-8D	8	245	198	172	7	27 1/2
PWB-9D	PVWB-9D	9	280	226	197	7	30 3/4

<sup>(1)</sup> MBH = 1,000 Btuh = British Thermal Unit Per Hour

\*\* Add 5 1/2" to height for vent Damper.

<sup>(2)</sup> For altitudes above 2,000 ft. rating should be reduced at the rate of 4% for each 1,000 ft. above sea level.

<sup>(3)</sup> Heating Capacity is based on D.O.E. (Department of Energy) test procedure.

<sup>(4)</sup> Net I=B=R Water rating shown based on piping and pickup allowance of 1.15. Consult manufacturer before selecting boiler for installations having unusual piping and pickup requirements, such as intermittent system operation, extensive piping systems, etc.

<sup>(5)</sup> 2 Section boiler equipped with 3" diameter flue collar. Use 3" x 4" increaser fitting to install furnished 4" vent damper.

Ratings marked "Net I=B=R Ratings" indicate amount of remaining heat input that can be used to heat the radiation or terminal units. Net I=B=R Ratings shown are based on allowance of 1.15 in accordance with factors shown on the I=B=R Standard as published by The Hydronics Institute.

Selection of boiler size should be based upon "Net I=B=R Rating" being equal to or greater than calculated heat loss of the building. Consult manufacturer before selecting boiler for installations having unusual piping and pickup requirements.

These boilers must stand on non-combustible floor. If installed on combustible floor, use Combustible Floor Base Number 42135-1 or 146-14-031 (2-6 section boilers) or 42135-2 or 146-14-032 (7-9 section boilers).

### BOILERS FOR USE AT HIGH ALTITUDE

Boiler is factory equipped for use at altitudes of 0-2,000 feet above sea level. For use at altitudes above 2,000 feet above sea level, input ratings are reduced by change in main burner orifice size. For altitudes above 2,000 feet above sea level, input ratings should be reduced at rate of 4% for each 1,000 feet above sea level. Consult National Fuel Gas Code (NFPA 54/ANSI Z223.1), or manufacturer for correct orifice sizing information. High altitude orifices are available from boiler manufacturer.

## BEFORE YOU START

Check to be sure you have the right size boiler before starting the installation. See rating and capacity table on previous page. Also be sure the new boiler is or the type of gas you are using. Check the rating plate on the right side of the boiler.

You must see that the boiler is supplied with the correct type of gas, fresh air for combustion, and a suitable electrical supply. Also, the boiler must be connected to a suitable venting system and an adequate piping system. Finally, a thermostat, properly located, is needed for control of the heating system. If you have any doubts as to the various requirements, check with local authorities and obtain professional help where needed. Take the time to complete all of the steps for SAFE and PROPER operation of the heating system.

If this boiler is installed in a building under construction, special care must be taken to insure a clean combustion air supply during the construction process. Airborne particulates such as from drywall dust and from fiberglass insulation can clog the burner ports and cause incomplete combustion and sooting.

Where required by the authority having jurisdiction, the installation must conform to Standard for Controls and Safety Devices for Automatically Fired Boilers, ANSI/ASME. CSD-1.

The installation must conform to the requirements of the authority having jurisdiction or, in the absence of such requirements, to the National Fuel Gas Code, ANSI Z223.1 /NFPA 54.

### KEEP BOILER AREA CLEAN AND FREE FROM COMBUSTIBLE MATERIALS, GASOLINE AND OTHER FLAMMABLE VAPORS AND LIQUIDS

## LOCATING THE BOILER

1. Select level location as centralized with piping system, and as near chimney, as possible.
2. Place crated boiler at selected location, remove crate by pulling crate sides from top and bottom boards. Combustible floors: When boiler is to be installed on a combustible floor, a Special Base Plate must be used - 146-14-031 (2-6 Section) or 146-14-032 (7-9 Section). This boiler must not be installed on carpeting.
3. Boiler is to be level. Metal shims may be used under base legs for final leveling.
4. **Accessibility clearances.** Maintain 18-inch clearance on any side where passage is required to access another side for cleaning, servicing, inspection or replacement of any part that may need attention. An 18-inch clearance is recommended on the control side for servicing.
5. Equipment shall be installed in a location in which the facilities for ventilation permit satisfactory combustion of gas, proper venting, and maintenance of ambient temperature at safe limits under normal conditions of use. Equipment shall be located so as not to interfere with proper circulation of air. When normal infiltration does not provide the necessary air, outside air shall be introduced (See Page 4 - "Fresh Air for Combustion").
6. Advise owner to keep air passages free of obstructions. Ventilating and combustion air must enter boiler room without restrictions.
7. The boiler shall be installed such that the automatic gas ignition system components are protected from water (dripping, spraying, rain, etc.) during appliance operation and service (circulator replacement, control replacement, etc.).

### MINIMUM CLEARANCE TO COMBUSTIBLE MATERIALS

	2-5	6-9
	Alcove	Alcove
Top	6"	6"
Rear	6"	6"
Right Side	8"	24"
Left Side	6"	24"
Front	18"	18"
Flue/Vent Connector	6"	6"
Near Boiler Piping	1"	1"

Boiler Size	Boiler Volume (Cu. Ft.)
2 section	3.8
3 section	5.4
4 section	7.0
5 section	8.5
6 section	10.1
7 section	11.7
8 section	13.2
9 section	14.8

**WARNING**



Air openings to combustion area must not be obstructed. Following instructions below, adequate combustion air can be maintained.

Provide combustion air and ventilation air in accordance with the section "Air for Combustion and Ventilation," of the National Fuel Gas Code, ANSI Z223.1 / NFPA 54, or applicable provisions of local building codes.

Provide make-up air where exhaust fans, clothes dryers, and kitchen ventilation equipment interfere with proper operation.

National Fuel Gas Code recognizes several methods of obtaining adequate ventilation and combustion air. Requirements of the authority having jurisdiction may override these methods.

- Engineered Installations. Must be approved by authority having jurisdiction.
- Mechanical Air Supply. Provide minimum of 0.35 cfm per Mbh for all appliances located within space. Additional requirements where exhaust fans installed. Interlock each appliance to mechanical air supply system to prevent main burner operation when mechanical air supply system not operating.
- All Indoor Air. Calculate minimum volume for all appliances in space. Use a different method if minimum volume not available.
  - A. Standard Method. Cannot be used if known air infiltration rate is 0.40 air changes per hour. See Table 1 for space with boiler only. Use equation for multiple appliances.

$$\text{Volume} \geq 50 \text{ ft}^3 \times \text{Total Input [Mbh]}$$

- B. Known Air Infiltration Rate. See Table 1 for space with boiler only. Use equation for multiple appliances. Do not use an air infiltration rate (ACH) greater than 0.60.

$$\text{Volume} \geq 21 \text{ ft}^3/\text{ACH} \times \text{Total Input [Mbh]}$$

- C. Refer to National Fuel Gas Code for opening requirements between connected indoor spaces.
  - All Outdoor Air. Provide permanent opening(s) communicating directly or by ducts with outdoors.
    - A. Two Permanent Opening Method. Provide opening commencing within 12 inches of top and second opening commencing within 12 inches of bottom of enclosure.
      - Direct communication with outdoors or communicating through vertical ducts. Provide minimum free area of 1 in<sup>2</sup> per 4 Mbh of total input rating of all appliances in enclosure.
      - Communicating through horizontal ducts. Provide minimum free area of 1 in<sup>2</sup> per 2 Mbh of total input rating of all appliances in enclosure.
    - B. One Permanent Opening Method. Provide opening commencing within 12 inches of top of enclosure. Provide minimum clearance of 1 inch on sides/back and 6 inches on front of boiler (does not supersede clearance to combustible materials).
    - C. Refer to National Fuel Gas Code for additional requirements for louvers, grilles, screens and air ducts.
  - Combination Indoor and Outdoor Air. Refer to National Fuel Gas Code for application information.

Table 1 - Minimum Room Volume, Indoor Air Only\*

Input Mbh	Standard Method	Known Air Infiltration Rate Method (Air Changes Per Hour)					
		0.1	0.2	0.3	0.4	0.5	0.6
37.5	1875	7875	3938	2625	1969	1575	1313
70	3500	14700	7350	4900	3675	2940	2450
105	5250	22050	11025	7350	5513	4410	3675
140	7000	29400	14700	9800	7350	5880	4900
175	8750	36750	17375	12250	9188	7350	6125
210	10500	44100	22050	14700	11025	8820	7350
245	12250	51450	25725	17150	12863	10290	8575
280	14000	58800	29400	19600	14700	11760	9800

\* Table values based on boiler only. Add volume for any additional appliances.

**WARNING**



Burn and scald hazard. Safety relief valve could discharge steam or hot water during operation. Install discharge piping per these instructions

1. Place boiler in the selected location (as near chimney as possible.) Your boiler is shipped assembled. You need only to install Safety Relief Valve and drain line to carry any water or steam to drain.
2. Install Safety Relief Valve into the 3/4" pipe on the top of the boiler. See Figure 5. Use 3/4" Pipe and an elbow (not furnished) to carry the water or steam to a nearby drain.
  - Install safety relief valve with spindle in vertical position.
  - Do not install shutoff valve between boiler and safety relief valve.
  - Install discharge piping from safety relief valve.
  - Use 3/4" or larger pipe.
  - Use pipe suitable for temperatures of 375°F (191°C) or greater.
  - Individual boiler discharge piping shall be independent of other discharge piping.
  - Size and arrange discharge piping to avoid reducing safety relief valve relieving capacity below minimum relief valve capacity stated on rating plate.
  - Run pipe as short and straight as possible to location protecting user from scalding and properly drain piping.
  - Install union, if used, close to safety relief valve outlet.
  - Install elbow(s), if used, close to safety relief valve outlet and downstream of union (if used).
  - Terminate pipe with plain end (not threaded)
3. Install temperature pressure gauge on boiler:
  - Remove box containing new gauge from parts bag. Remove gauge from box.
  - Apply pipe sealant to threads on shaft of gauge. See Figure 1.
  - Thread gauge into supply water tee. See Figure 2.

**IMPORTANT: DO NOT TIGHTEN GAUGE BY HAND!!** Tighten gauge using crescent wrench or 9/16" open end wrench. See Figure 3.

Figure #1



Figure #2



Figure #3

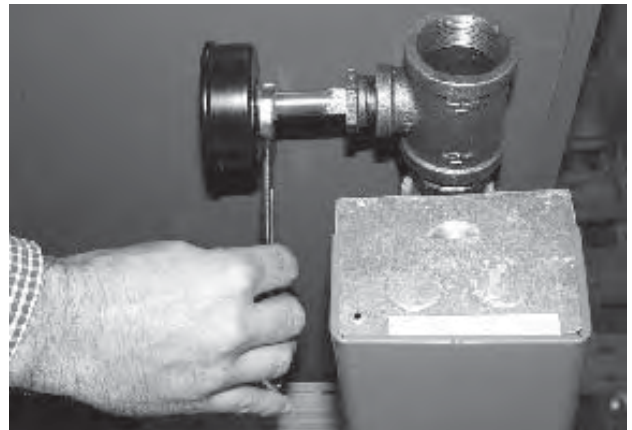

Figure 4



**LOW DESIGN WATER TEMPERATURE SYSTEMS  
(BELOW 140° F)**

Install 3-way or 4-way mixing valve (or suitable alternative) to prevent low temperature return water from entering boiler when used in heating system designed for low water temperature (below 140°F, e. g. radiant floor heating). Follow mixing valve manufacturer's installation instructions.

- Remove sticker from front of gauge. See Figure 4.
4. Connect Supply and Return Piping to boiler. Connections may require certain additional fittings and parts, as shown on diagram (Figs. 5 and 6).
  5. Boiler equipped with 1-1/4" supply and return connections on both left and right sides of boiler. In connecting cold water supply to water inlet valve, make sure clean water supply is available. When water supply is from a well or pump, install sand strainer at pump.  
Hot water boiler installed above radiation level or as required by Authority having jurisdiction must be equipped with low water cutoff device at time of installation. Periodic inspection is necessary, as is flushing of float type devices, per manufacturer's specific instruction.

**FOR USE WITH COOLING UNITS**

- A. This boiler, when used in connection with a refrigeration system, must be installed so that the chilled medium is piped in parallel with the heating boiler. Appropriate valves must be used to prevent the chilled medium from entering the heating boiler (Fig. 6).
- B. When this boiler is connected to heating coils located in air handling units where they may be exposed to refrigerated air circulation, the piping system shall be equipped with flow control valves or other automatic means to prevent gravity circulation of the boiler water during the cooling cycle.

FIG. 5 - TYPICAL HOT WATER PIPING

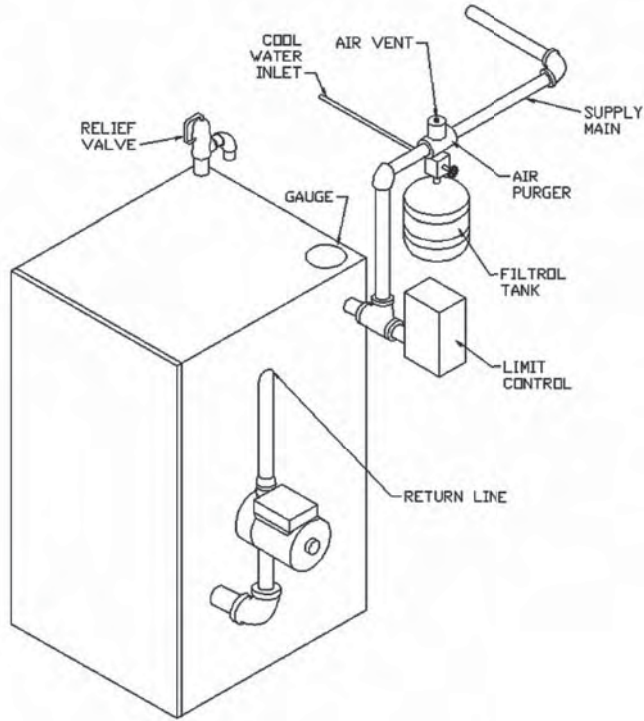
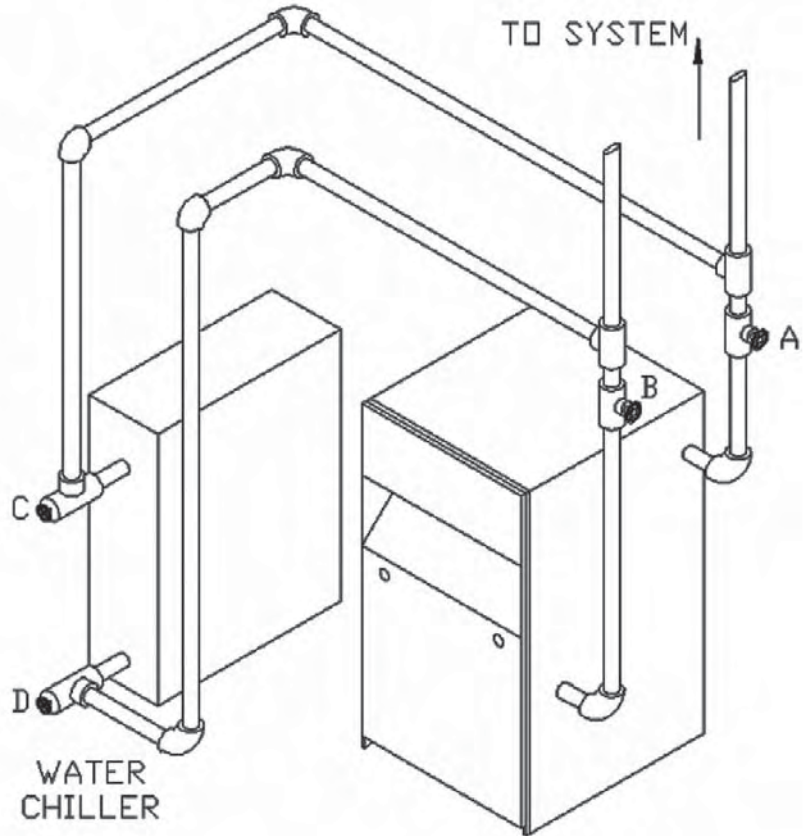

FIG. 6 - CHILLED WATER PIPING

VALVES A & B  
OPEN FOR HEATING;  
CLOSE FOR COOLING

VALVES C & D  
CLOSE FOR HEATING;  
OPEN FOR COOLING



**For boilers for connection to gas vents or chimneys, vent installations shall be in accordance with “Venting of Equipment”, of the National Fuel Gas Code, ANSI Z223.1/ NFPA 54, or applicable provisions of local building codes.**

### CHECK YOUR CHIMNEY

This is a very important part of your heating system. It must be clean, the right size, properly constructed and in GOOD CONDITION. No boiler can function properly with a bad chimney.

### CHIMNEY SIZING

Install vent in accordance with “Venting of Equipment” of the National Fuel Gas Code, ANSI Z223.1/NFPA 54, or applicable provisions of local building codes.

### CONNECTING THE VENT DAMPER AND VENT CONNECTOR

Refer to figure on page 2 for size and location of vent (flue opening).

**IMPORTANT** - The damper blade on the furnished vent damper has a 1/2 square inch hole (approximately 3/4” diameter). On boilers equipped with standing pilot, the hole must be left open. On boilers equipped with intermittent ignition, the hole should be plugged by using the plug supplied with the vent damper.

1. Position furnished vent damper on top of flue outlet collar. Fasten damper securely to flue outlet collar with sheet metal screws. Make sure damper blade has clearance to operate inside of diverter. Do not modify either draft diverter or vent damper during installation.

On 2 section boilers equipped with vent damper, supplied 4-inch vent damper is equipped with 3-inch to 4-inch adapter so that 4-inch vent damper may be installed on boiler’s 3-inch flue outlet collar. Fasten all fittings securely.

### As An Option

Damper may be installed in any horizontal or vertical position, closer to flue outlet collar preferred. Follow diagrams - Figures #9, #10 and #11.

2. Install vent damper to service only single boiler for which it is intended. Damper position indicator shall be in visible location following installation. Locate damper so that it is accessible for servicing.
3. Damper must be in open position when appliance main burners are operating.
4. Boiler is equipped with factory wired harness that plugs into vent damper.
5. Vent pipe must be same size as the flue outlet collar, except 2 section boilers with vent damper as noted above.
6. Slope pipe up from boiler to chimney not less than 1/4” per foot.

7. Run pipe as directly as possible with as few elbows as possible.
8. Do not connect to fireplace flue.
9. End of vent pipe must be flush with inside face of chimney flue. Use a sealed-in thimble for the chimney connection.

Sections of vent pipe should be fastened with sheet metal screws to make piping rigid. Support horizontal portions of vent system to prevent sagging. Use stovepipe wires every 5’ to support pipe from above. If vent pipe must go through crawl space, double wall vent pipe should be used. Where vent pipe passes through combustible wall or partition, use ventilated metal thimble. Thimble should be 4 inches larger in diameter than vent pipe.



### MINIMUM VENT PIPE CLEARANCE

Wood and other combustible materials must not be closer than 6" from any surface of single wall metal vent pipe. Listed Type B vent pipe or other listed venting systems shall be installed in accordance with their listing.

### REMOVING EXISTING BOILER FROM COMMON VENTING SYSTEM

When an existing boiler is removed from a common venting system, the common venting system is likely to be too large for proper venting of the appliances remaining connected to it.

At the time of removal of an existing boiler, the following steps shall be followed with each appliance remaining connected to the common venting system placed in operation, while the other appliances remaining connected to the common venting system are not in operation.

1. Seal any unused openings in the common venting system.
2. Visually inspect the venting system for proper size and horizontal pitch and determine there is no blockage or restriction, leakage, corrosion and other deficiencies which could cause an unsafe condition.
3. Insofar as is practical, close all building doors and windows and all doors between the space in which the appliances remaining connected to the common venting system are located and other spaces of the building. Turn on clothes dryers and any appliance not connected to the common venting system. Turn on any exhaust fans, such as range hoods and bathroom exhausts, so they will operate at maximum speed. Do not operate a summer exhaust fan. Close fireplace dampers.
4. Place in operation the appliance being inspected. Follow the lighting instructions. Adjust thermostat so appliance will operate continuously.
5. Test for spillage at the draft hood relief opening after 5 minutes of main burner operation. Use the flame of a match or candle, or smoke from a cigarette, cigar or pipe.
6. After it has been determined that each appliance remaining connected to the common venting system properly vents when tested as outlined above, return doors, windows, exhaust fans, fireplace dampers and any other gas-burning appliance to their previous conditions of use.
7. Any improper operation of the common venting system should be corrected so the installation conforms with the National Fuel Gas Code, ANSI Z223.1/NFPA 54. When re-sizing any portion of the common venting system, the common venting system should be re-sized to approach the minimum size as determined using the appropriate tables in Chapter 13 of the National Fuel Gas Code, ANSI Z223.1/NFPA 54.

**Vent connectors serving appliances vented by natural draft shall not be connected into any portion of mechanical draft systems operating under positive pressure.**

FIG. 9

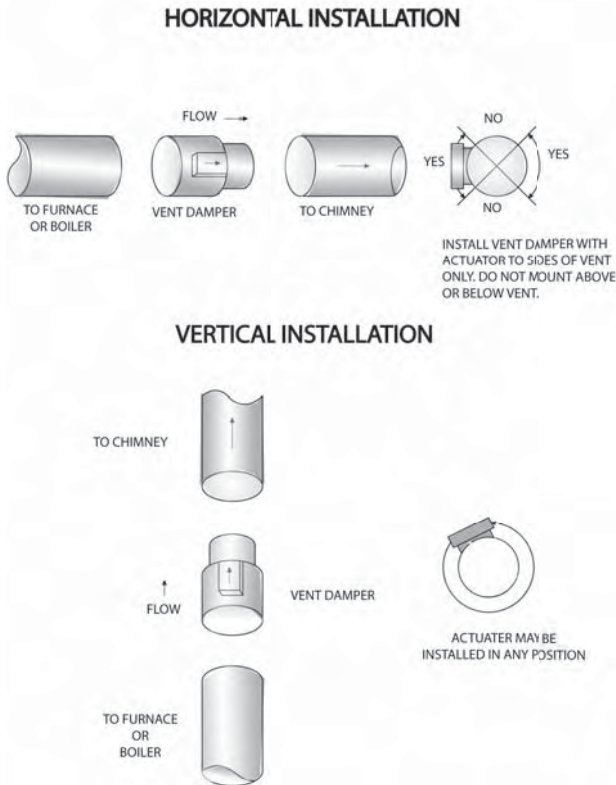
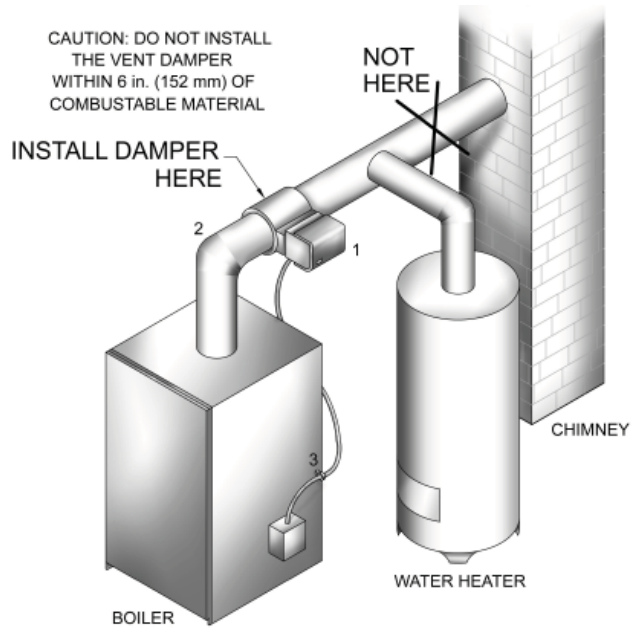

FIG. 10



For safe, efficient operation, the vent damper and all flue product carrying areas of the appliance must be checked annually by you, with particular attention given to deterioration from corrosion or other sources. If you see corrosion or other deterioration, contact your heating contractor for repairs. Check vent damper operation as follows:

For further information, and for a vent damper troubleshooting guide, refer to the manual that was packaged with the vent damper.

**The vent damper must be inspected at least once a year by a trained, experienced service technician. The name of the person who originally installed your vent damper is shown on the installation label.**

1. When the boiler is off, check that the vent damper positions indicator points to the closed position, Fig. 11.
2. Turn the thermostat or controller up to call for heat and check the vent damper indicator points to the open position, Fig. 11.
3. Turn the thermostat or controller down again and check that the damper position indicator returns to the closed position.

**MANUAL OPERATION OF THE VENT DAMPER**

The vent damper may be placed in the open position to permit burner operation by using the "HOLD DAMPER OPEN" switch, located on the damper controller. The thermostat will control the burner firing as before, while the damper will remain open. **DO NOT** turn damper open manually or motor damage will result. Set switch to "AUTOMATIC OPERATION" to close vent damper during burner off cycle.

FIG. 11 VENT DAMPER POSITION INDICATOR

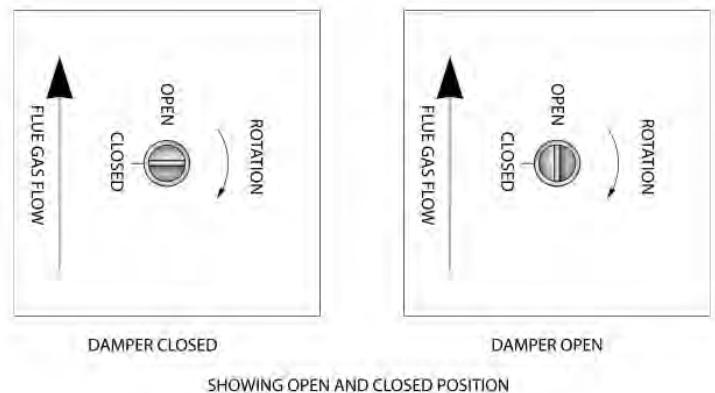

**CHECK GAS SUPPLY**

The gas pipe to your boiler must be correct size for length of run and for total BTU per hour input of all gas utilization equipment connected to it. See Fig. 12 for proper size. Be sure your gas line complies with local codes and gas company requirements.

**CONNECTING THE GAS PIPING**

Refer to Fig. 13 for the general layout at the boiler. It shows the basic fittings you will need. The gas line enters the boiler from the right side.

The following rules apply:

1. Use only those piping materials and joining methods listed as acceptable by the authority having jurisdiction, or in the absence of such requirements, by the National Fuel Gas Code, ANSI Z223.1/NFPA 54.
2. Use pipe joint compound suitable for LP gas on male threads only.
3. Use ground joint unions.
4. Install a sediment trap upstream of gas controls.
5. Use two pipe wrenches when making the connection to the gas valve to keep it from turning.
6. Install a manual shut-off valve in vertical pipe about 5 feet above floor.
7. Tighten all joints securely.
8. Propane gas connections should only be made by a licensed propane installer.
9. Two-stage regulation should be used by the propane installer.
10. Propane gas piping should be checked out by the propane installer.

**CHECKING THE GAS PIPING**

DANGER

!

Fire Hazard. Do not use matches, candles, open flames, or other methods providing ignition source. Failure to comply will result in death or serious injury.

Pressure test boiler and gas connection before placing boiler in operation.

- Pressure test over 1/2 psig (3.5 kPa). Disconnect boiler and its individual gas shutoff valve from gas supply system.
- Pressure test at 1/2 psig (3.5 kPa) or less. Isolate boiler from gas supply system by closing manual gas shutoff valve.
- Locate leakage using gas detector, noncorrosive detection fluid, or other leak detection method acceptable to authority having jurisdiction. Do not use matches, candles, open flames, or other methods providing ignition source.
- Correct leaks immediately and retest.

**FIG. 12 GAS PIPE SIZES**

NATURAL GAS				
	Pipe Capacity - BTU Per Hour Input Includes Fittings			
Length of Pipe - FT	1/2"	3/4"	1"	1 1/4"
20	92,000	190,000	350,000	625,000
40	63,000	130,000	245,000	445,000
60	50,000	105,000	195,000	365,000
PROPANE GAS				
	Pipe Capacity - BTU Per Hour Input Includes Fittings			
Length of Pipe - FT	Copper Tubing *		Iron Pipe	
	5/8"	3/4"	1/2"	3/4"
20	131,000	216,000	189,000	393,000
40	90,000	145,000	129,000	267,000
60	72,000	121,000	103,000	217,000

\* Outside diameter  
The length of pipe or tubing should be measured from the gas meter or propane second stage regulator.

**FIG. 13 - GAS PIPING**

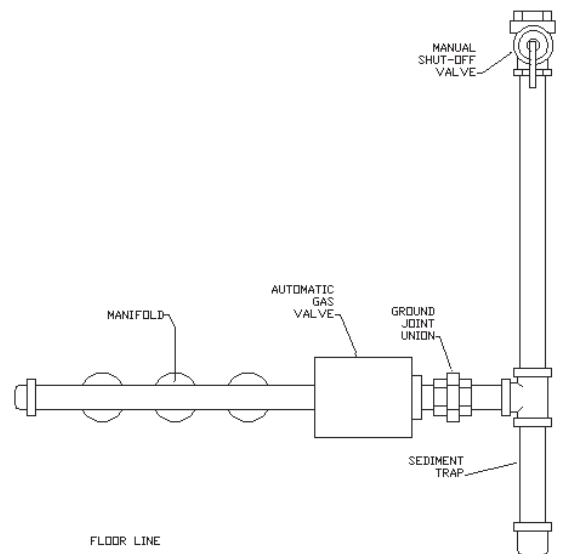

## ELECTRICAL WIRING

Electrical work must be in accordance with requirements of authority having jurisdiction or, in absence of such requirements, with National Electrical Code, ANSI/NFPA 70.

### ELECTRIC POWER SUPPLY

Run a separate 120 volt circuit from a separate over current protective device in the electrical service entrance panel. This should be a 15 ampere circuit. Locate a shut-off switch at the boiler. It must be turned off during any maintenance. Connect 120 volt power supply to aquastat terminals L1 (HOT) and L2. The boiler, when installed, must be electrically grounded in accordance with the requirements of the authority having jurisdiction or, in the absence of such requirements, with the National Electrical Code, ANSI/NFPA No. 70. Run a 14 gauge or heavier copper wire from the boiler to a grounded connection in the service panel or a properly driven and electrically grounded ground rod.



### WARNING

Turn off electric power at fuse box before making any line voltage connections. Follow local electrical codes.

### INSTALL YOUR THERMOSTAT

The thermostat location has an important effect on the operation of your boiler system. **BE SURE TO FOLLOW THE INSTRUCTIONS INCLUDED WITH YOUR THERMOSTAT.**

Locate the thermostat about five feet above the floor on an inside wall. It may be mounted directly on the wall or on a vertically mounted outlet box. It should be sensing average room temperature, so avoid the following:

#### DEAD SPOTS:

- Behind doors
- Corners and alcoves

#### HOT SPOTS:

- Concealed pipes
- Fireplace
- TV sets
- Radios
- Lamps
- Direct sunlight
- Kitchens

#### COLD SPOTS:

- Concealed pipes or ducts
- Stairwells - drafts
- Doors - drafts
- Unheated rooms on other side of wall

Set heat anticipator at .2 amps. 24 volt thermostat connects to aquastat terminals T and TV.

### VENT DAMPER WIRING

Boiler equipped with factory wired harness with 4 pin molex plug, that plugs into 4 pin molex receptacle inside vent damper operator.

Vent damper must be connected for boiler to operate.

Wiring diagrams follow for various different models.

### CIRCULATOR WIRING

Pump is not pre-installed on boiler. Connect circulator harness per pump manufacturer's instructions and wiring diagrams in this manual.



### CAUTION

Label all wires prior to disconnection when servicing controls. Wiring errors can cause improper and dangerous operation. Verify proper operation after servicing.

INTERMITTENT IGNITION

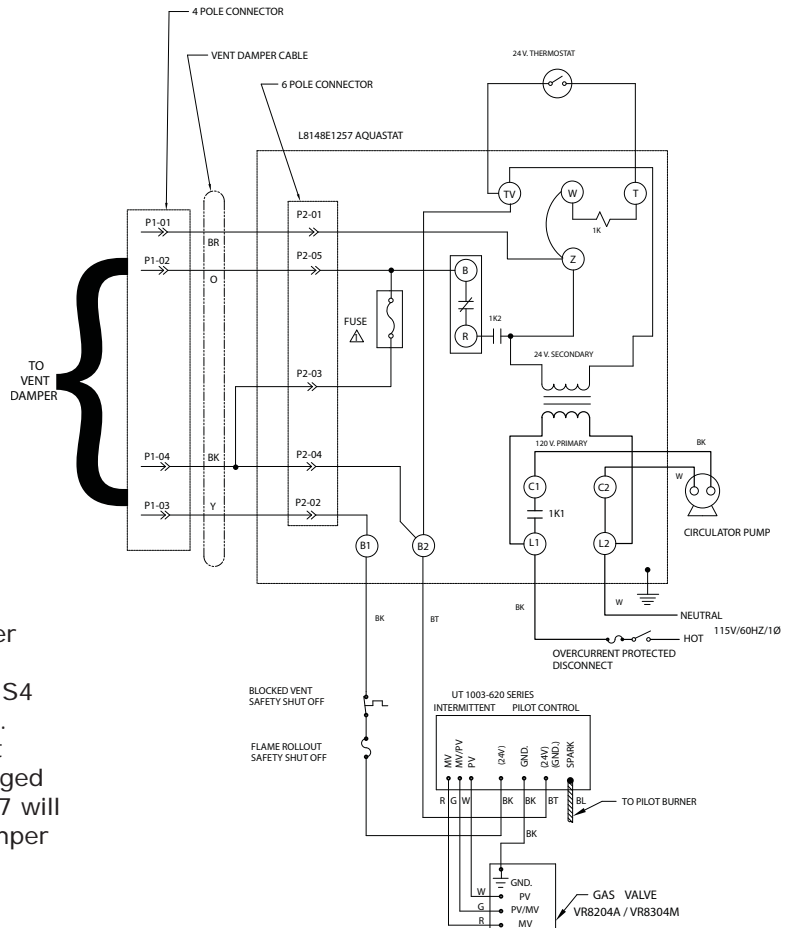
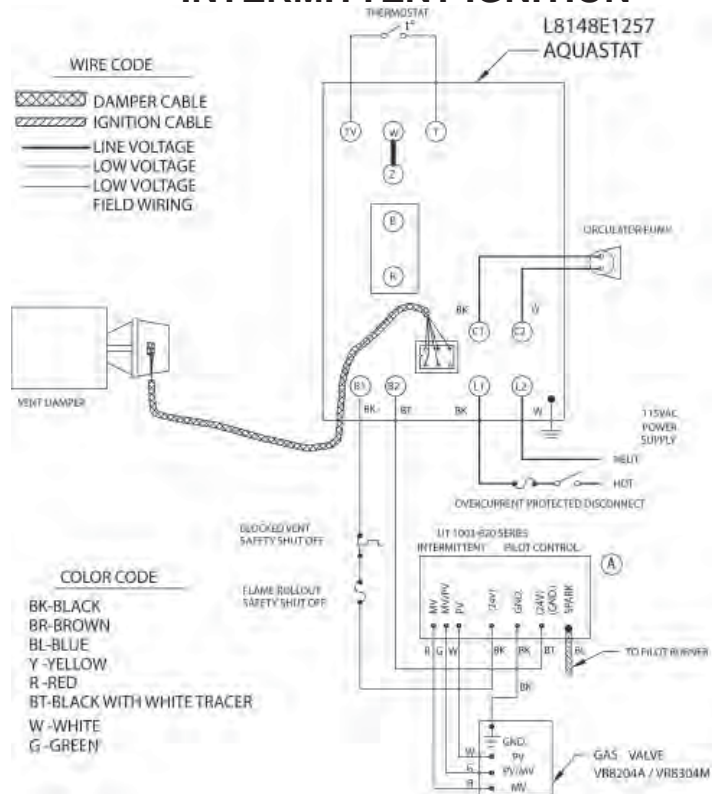

Note: S1A and S1B are the automatic operation/hold damper open switch. Switch is shown in automatic position. S2, S3 and S4 are cam actuated snap switches. Fuse blows first time thermostat closes after vent damper is plugged in. After fuse blows L8148E1257 will operate burners only if vent damper is connected (plugged in).

**IF ANY OF THE ORIGINAL WIRE AS SUPPLIED WITH THIS APPLIANCE MUST BE REPLACED, IT MUST BE REPLACED WITH TYPE 105°C THERMOPLASTIC WIRE OR ITS EQUIVALENT.**

STANDING PILOT

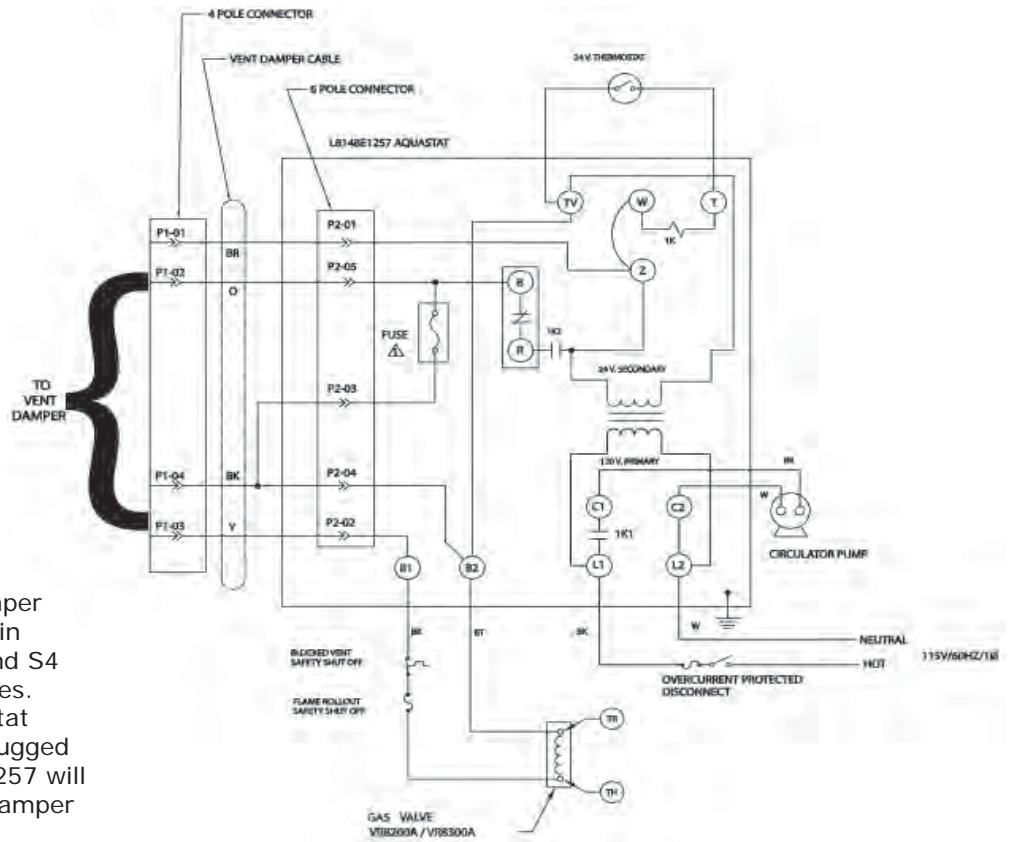
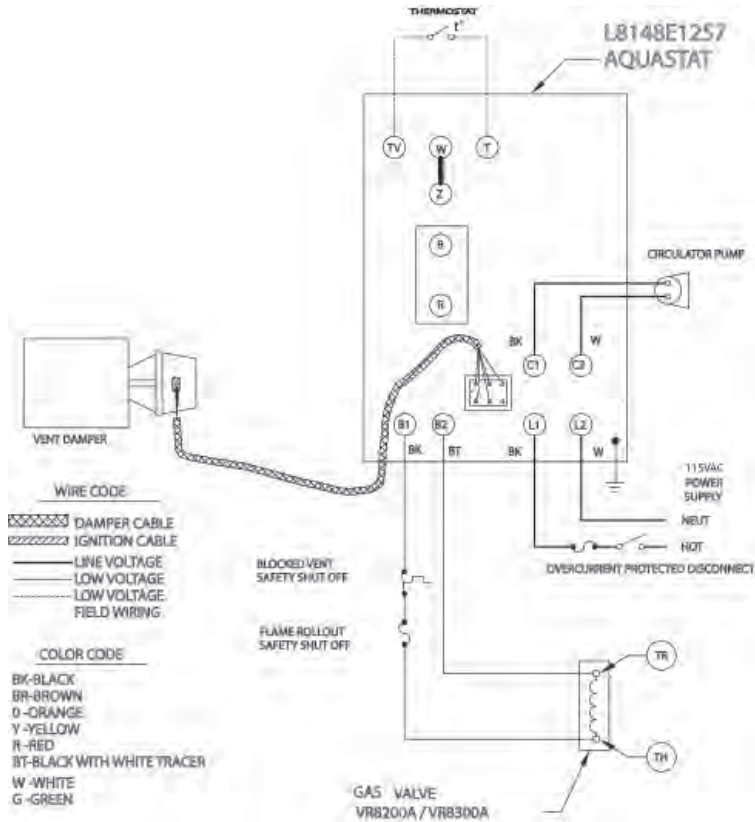

Note: S1A and S1B are the automatic operation/hold damper open switch. Switch is shown in automatic position. S2, S3 and S4 are cam actuated snap switches. Fuse blows first time thermostat closes after vent damper is plugged in. After fuse blows L8148E1257 will operate burners only if vent damper is connected (plugged in).

**IF ANY OF THE ORIGINAL WIRE AS SUPPLIED WITH THIS APPLIANCE MUST BE REPLACED, IT MUST BE REPLACED WITH TYPE 105°C THERMOPLASTIC WIRE OR ITS EQUIVALENT.**

**SAFETY RELIEF VALVE**

You must have a safety relief valve on your boiler. Water expands as it is heated. If there is no place for water to expand into, water pressure will build up inside boiler and system. Should this happen, safety relief valve will automatically open at predetermined pressure. This will relieve strain on boiler and system. Run a pipe from safety relief valve outlet (pipe must be same size as outlet and open end must not be threaded) to open drain, tub or sink, or other suitable drainage point not subject to freezing. Failure to do so may cause water damage or injury should safety relief valve release.

**EXPANSION TANK**

In a properly assembled system, the expanding water flows into a expansion tank. This tank should be of the correct size. The tank is filled with air. As the water expands it compresses the air in the tank to form an air pressure cushion. This "spring-like" cushion serves to maintain correct operating water pressure regardless of water temperature. This assures a "full measure" of a water, even in the highest radiation unit of the system. It also prevents blowing off of the relief valve. The air in the tank in the beginning (with system filled with cold water) is sufficient for proper operation. The tank also serves as a trap for excess air in the system. The air would cause gurgling in the pipes and inefficient circulation in the radiators if left in the system .

It is possible for tank to become "waterlogged" (filled with water). It can also become overfilled with air. This can happen after filling system with new water. Fittings provided on tank and in line to tank are for bleeding off excess water or air.

When installing this tank, it is important: 1) That the tank be higher than the boiler top. 2) That the pipe to the tank continuously rises up to the tank (so that air can "bubble" up to it).

**DIAPHRAGM TYPE EXPANSION TANK**

Diaphragm type expansion tank (EX-TROL) takes place of conventional expansion tank. Carefully read instructions packed with your EX-TROL tank assembly.

The EX-TROL tank comes to you with a 10-12 pounds per square inch air charge. This is the same as the pressure produced in the system by the automatic fill valve. When the system is first filled, the EX-TROL tank will contain little or no water.

As the water is heated its pressure increases. It expands into the EX-TROL tank, compressing the air in the tank. This compressed air cushion permits the water in the system to expand as the temperature changes. The diaphragm type tank can be mounted on the air purger fitting or at any convenient place in the supply or return line.

**AIR ELIMINATING FITTING (AIR PURGER)**

An air purger is used to remove excess air from the system. It is installed in the supply line. It will eliminate air from the water before it reaches the radiators and bleed off this air.

**MAIN AIR VENT FOR DOWN FLOW SYSTEMS OR DIAPHRAGM TYPE EXPANSION TANK**

Before a system is filled with water, there is air in the pipes and radiation units. Some of it will be trapped as the system is filled . It is possible to eliminate most of this air through the air vent on the radiation units. A main air vent will speed and simplify this. It should be installed on the highest point in the supply main when all radiation is below top of boiler.

**AUTOMATIC FILL VALVE**

For safe, efficient operation, a hot water system must be **completely filled** with water. Adding new water, when needed can be done manually (by use of a hand valve in the water supply line). This requires regular attention to the system's needs. An automatic fill valve accomplishes this without attention. It is installed in the supply line on hot water boilers only. The valve operates through water pressure differentials. It does not require an electrical connection.

**DRAIN VALVE**

This manual valve Provides a means of draining all water from the boiler and system. It is often installed in the 3/4" tapping at the bottom of the end boiler section. Or it can be installed in a tee where the return line enters the boiler.

**WATER TEMPERATURE CONTROL**

The water temperature limit control in the relay is adjustable and may be set as necessary. It may be set as low as 140°F, or as high as 240°F. This depends on the type and amount of radiation involved and weather conditions.

**CIRCULATING PUMP**

Every forced hot-water system requires a circulating pump. A separate pump or zone valve is required for each zone, if you have a two or more zone system. This pump must have the capacity to provide the circulation required by your system. The pump is connected into the main just ahead of the boiler. It is also wired to the electrical system.

**VENT DAMPER**

This product is an automatic, motorized stack damper that has been developed to increase the efficiency of heating system by reducing standby losses from the heating apparatus and the conditioned air space. The damper closes the chimney vent when the burner is off and fully opens it when combustion is required.

### ROLLOUT SWITCH (FLAME ROLLOUT SAFETY SHUTOFF)

The rollout switch is a temperature-sensitive fuse link device. It is located on the boiler base just outside the fire box. In the event of heat exchanger flueway blockage causing flame to roll out of the fire box, the fuse does not change in appearance when blown.

If the rollout switch blows, it must be replaced with an exact replacement. Check heat exchanger flueways for blockage when restoring system to operating condition. DO NOT operate system without a rollout switch.

### SPILL SWITCH (BLOCKED VENT SAFETY SHUTOFF)

The spill switch is a manual reset disc thermostat with a fixed setpoint (340° F), and normally closed contacts. It is located at the relief opening of the integral draft diverter. In the event of chimney or venting system blockage causing products of combustion to spill out of the relief opening, the spill switch disc heats up and the spill switch contacts open, shutting down the flow of gas to the main burners by removing power to the gas valve.

In the event that the spill switch contacts open, the reset button on the back of the switch will pop up. The spill switch must be reset manually, after the switch has cooled off, by pushing the reset button down. Check the venting system and chimney for blockage when restoring the system to operating condition. DO NOT operate the boiler without a spill switch.

## STARTING YOUR BOILER

### HOW A HOT-WATER SYSTEM OPERATES

Your entire heating system (boiler, piping and radiation units) is filled with water. As the water in the boiler is heated, it is pumped from the top of the boiler through the supply main to the radiation units. The cooler water in them flows back through the return main to the boiler. This provides positive and rapid response to the thermostat.

### FILLING SYSTEM WITH WATER

Close the air vents on all radiation units. Open the valves to these units. Make sure the boiler and expansion tank drain cocks are closed. The air bleed screw on the tank drain fitting should be closed. Open the valve in the line from the boiler to the expansion tank. Open the water inlet to your boiler and leave it open. Start with the **lowest** radiation unit. Open the air vent on this unit. When all the air has escaped and water starts to flow from the vent, close it. Go to the next radiation unit, and repeat this process. Repeat until you have covered every radiation unit in the system (ending up at the highest unit in the system). If your units have automatic vents, this manual venting is unnecessary but it will speed up the proper filling of your system.

If your system is a closed expansion tank system, you may leave it open to refill the system automatically as needed. Check the temperature pressure gauge. Note the position of the hand indicating pressure. This should be between 10 and 15 psi. Any lowering of this movable hand below 10 psi. Will indicate loss of water due to leakage. The automatic fill valve should compensate for this. Instructions are packages with the valve.



### WARNING

Never run water into a hot empty boiler.



**WARNING**



If you do not follow these instructions exactly, a fire or explosion may result causing property damage, personal injury or loss of life.

- A. Some boilers are equipped with an intermittent ignition device which automatically lights the pilot. Do **not** try to light the pilot by hand.

Some boilers are equipped with a continuous pilot and must be manually lighted. (See lighting instructions on page 18). A match holder is included in the parts bag.

- B. BEFORE OPERATING smell all around the appliance area for gas. Be sure to smell next to the floor because some gas is heavier than air and will settle on the floor.

**WHAT TO DO IF YOU SMELL GAS**

- Do not try to light any appliance.
  - Do not touch any electric switch; do not use any phone in your building.
  - Immediately call your gas supplier from a neighbor's phone. Follow the gas supplier's instructions.
  - If you cannot reach your gas supplier, call the fire department.
- C. Use only your hand to push in or turn the gas control knob. Never use tools. If the knob will not push in or turn by hand, don't try to repair it, call a qualified service technician. Force or attempted repair may result in a fire or explosion.
- D. Do not use this appliance if any part has been under water. Immediately call a qualified service technician to inspect the appliance and to replace any part of the control system and any gas control which has been under water.

**INTERMITTENT IGNITION BOILER - VR8204A/VR8304M GAS VALVE OPERATING INSTRUCTIONS**

1. STOP! Read the safety information above.
2. Set the thermostat to lowest setting.
3. Turn off all electric power to the appliance.
4. This appliance is equipped with an ignition device which automatically lights the pilot. Do **not** try to light the pilot by hand.

7. Wait five (5) minutes to clear out any gas. Then smell for gas, including near the floor. If you smell gas, STOP! Follow "B" in the safety information above. If you don't smell gas, go to next step.
8. Rotate gas control knob counterclockwise  to "ON".
9. Replace lower front panel.
10. Turn on all electric power to the appliance.
11. Set thermostat to desired setting.
12. If the appliance will not operate, follow the instructions "To Turn Off Gas To Appliance" and call your service technician or gas supplier.

**TO TURN OFF GAS TO APPLIANCE**

5. Remove lower front panel.
6. Rotate the gas control knob clockwise  to "OFF".

1. Set the thermostat to lowest setting.
2. Turn off all electric power to the appliance if service is to be performed.
3. Push in gas control knob slightly and turn clockwise  to "OFF" Do not force.

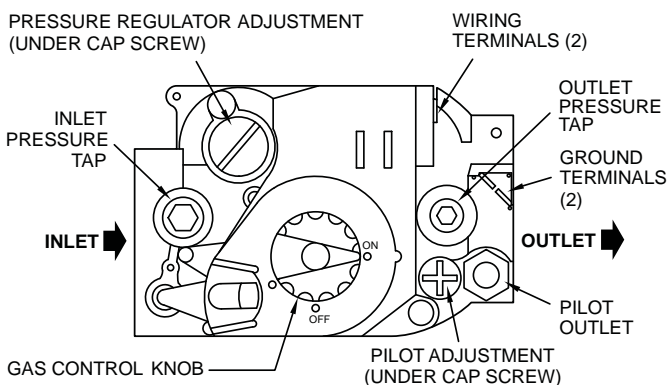

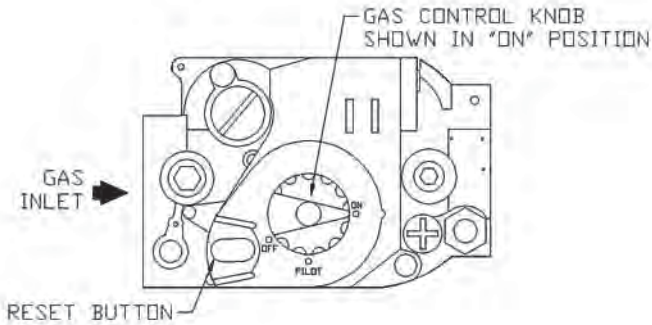

## CONTINUOUS PILOT BOILER - VR8200A/VR8300A GAS VALVE OPERATING INSTRUCTIONS

1. STOP! Read the safety information on page 17.
2. Set the thermostat to lowest setting.
3. Turn off all electric power to the appliance.
4. Remove lower front panel.
5. Rotate gas control knob slightly and turn clockwise to "OFF" 



6. Wait five (5) minutes to clear out any gas. Then smell for gas, including near the floor. If you smell gas, STOP! Follow "B" in the safety information on page 17. If you don't smell gas, go to next step.
7. Find pilot - follow metal tube from gas control. The pilot is between two burner tubes as shown in Fig. 14.
8. Turn knob on gas control counterclockwise to "PILOT" 

9. Rotate the gas control knob counterclockwise to "PILOT" Push down and hold the red reset button while you light pilot burner with a match. After about one minute, release reset button. Pilot should remain lit. If it goes out, turn gas control knob clockwise to OFF To relight, repeat steps 5-9. 

- If button does not pop up when released, stop and immediately call your service technician or gas supplier.
  - If the pilot will not stay lit after several tries, turn the gas control knob to "OFF" and call your service technician or gas supplier.
10. After pilot remains lit when red reset button is released, turn gas control knob counterclockwise to "ON." 
  11. Replace lower front panel.
  12. Turn on all electric power to the appliance.
  13. Set thermostat to desired setting.

### TO TURN OFF GAS TO APPLIANCE

1. Set the thermostat to lowest setting.
2. Turn off all electric power to the appliance if service is to be performed.
3. Push in gas control knob slightly and turn clockwise to "OFF" Do not force. 

## OPERATING YOUR BOILER

### AUTOMATIC GAS VALVE

Automatic Gas Valve opens or closes according to heat requirements of thermostat and temperature limit control. It closes if pilot goes out. Each individual control must be operating correctly before any gas can pass to burners. Any one control can hold gas supply from burner regardless of demand of any other control.

### SAFETY PILOT

Safety Pilot prevents flow of gas to burner if pilot goes out, or will not ignite.

### GAS VALVE SAFETY SHUTDOWN TEST

Ignition system safety shutoff device must be tested after placing boiler in operation.

1. For boilers equipped with continuous pilot, with main burners firing, disconnect the thermocouple from the gas valve. The gas valve should immediately shut off main burners and the pilot.
2. For boilers equipped with intermittent ignition, with main burners firing, disconnect ignition cable from intermittent pilot control box. Gas valve should shut off main burners.

TURN OFF ELECTRIC POWER to boiler before reconnecting ignition cable, to prevent electric shock.

### RELIGHT

Electric and gas shall be off for 5 minutes before relighting.

### THERMOSTAT

Keep it set at desired room temperature. If windows are to be opened or heat is not needed, move thermostat pointer to lower setting.

### NOTICE

In event of failure of any component, system will not operate or will go into safety lockout. System is completely self-checking. On every call for heat, each component must be functioning properly to permit operation. On safety lockout system has to be reset by turning thermostat to lowest setting for one minute, then back to normal setting.

FIG. 14 - LIGHTING PILOT

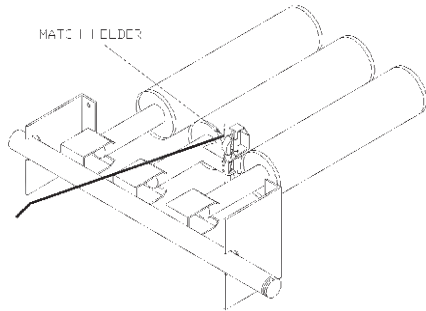

FIG. 15 -VR8200A/VR8300A AUTOMATIC GAS VALVE

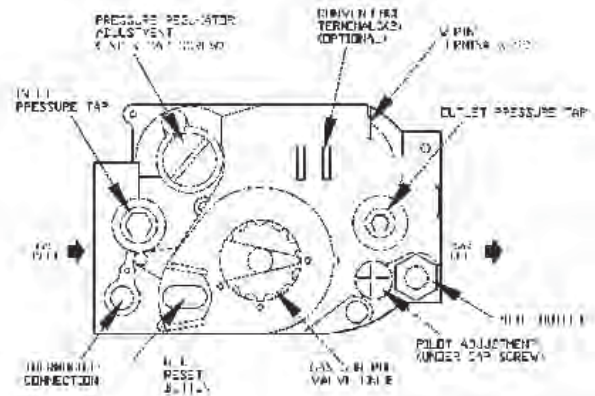

FIG. 16 -VR8204A/VR8304M AUTOMATIC GAS VALVE

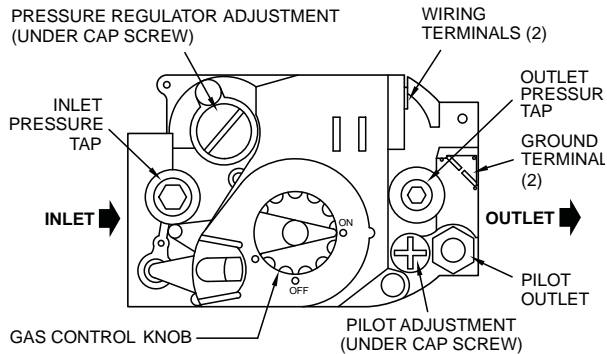
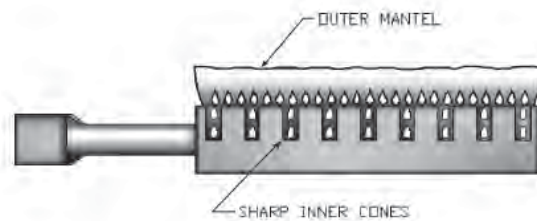

FIG. 17



OPERATING YOUR BOILER

**ADJUST PILOT BURNER**

Pilot flame should surround 3/8" to 1/2" of the pilot sensor. Refer to Fig. 18. If flame needs adjusting, do it as follows:

1. Remove screw cover over pilot adjusting screw.
2. Insert small screwdriver and adjust flame as needed.  
Turn screw counterclockwise to increase flame, clockwise to decrease.
3. Replace screw cover over pilot adjusting screw.

**MAIN BURNER(S)**

The main burners do not require primary air adjustment and are not equipped with primary air shutters. Main burner flames should form sharp blue inner cones in a softer blue outer mantel, with no yellow. Puffs of air from blowing on the flame or stamping on the floor will cause the flames to turn orange momentarily. This is not unusual. Remain still when observing the main burner flames. If the flame appearance is not correct, check main burner orifices and the burner throat and flame ports for dust and lint obstruction. It may be necessary to remove the rollout shield to observe the main burner flames. Replace rollout shield after observation. Refer to Figure 17.

**ADJUST LIMIT CONTROLS**

Instructions for each control are included with the controls. These settings can be changed after you have had some idea how the system works. Example: If your system does not give quite enough heat in very cold weather, you can raise the limit setting to 220° F Use the boiler gauge to check your settings. Make the adjustments according to its readings.

**RECOMMENDED BOILER WATER TEMPERATURES**

Type of Heating Unit	Limit Control Setting
Standing Radiators.....	180° F.
Baseboard and Convector Radiators.....	200° F.

Check thermostat operation. When set above temperature indicated on the thermometer, boiler should ignite. Make certain the thermostat turns off the boiler when room temperature reaches the selected setting and starts the boiler operating when room temperature falls a few degrees.

After setting limit control to limit setting, check to see if it shuts off the gas supply to the burners. Turn your thermostat up to call for heat and let your boiler run until the temperature of the water reaches the limit setting. The gas valve should shut off and the circulator keep running until the thermostat is satisfied, or the water cools enough to restart the burners through the limit control.

Finally, set the thermostat for the desired temperature. Special conditions in your home and the location of the thermostat will govern this setting.

FIG. 18

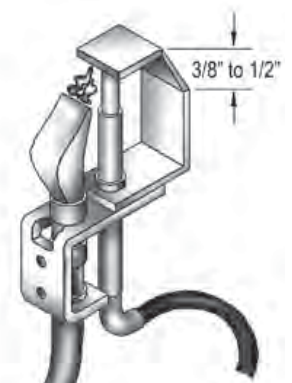

### BURNERS

A visual check of the pilot and main burner flames should be made at least once each year, preferably at the beginning of the heating season. See page 17

### SAFETY RELIEF VALVE

This valve should open automatically if the system pressure exceeds the pressure rating (usually 30 psi) of the safety relief valve. Should it ever fail to open under this condition, shut down your system. Drain the system until system pressure is reduced below the safety relief valve pressure rating. If valve discharge occurs, or if valve fails to open as described above, contact an authorized contractor or qualified service technician to replace the relief valve and inspect the heating system to determine the cause, as this may indicate an equipment malfunction. This valve should be tested every month during periods of boiler operation, and at the beginning and end of any extended non-service period. Prior to testing, make certain discharge pipe is properly connected to valve outlet and arranged so as to contain and safely dispose of boiler discharge. Test at normal system operating pressure. Hold the trip lever fully open for at least five seconds in order to flush free any sediment that may lodge on the valve seat. Then permit the valve to snap shut.

### EXPANSION TANK

As previously noted, this tank may become waterlogged, or may receive an excess of air. Frequent automatic opening of the relief valve indicates water logging. A high boiler temperature accompanied by unusually low radiation unit temperature (and "knocking") indicates excess air in tank.

To correct either condition, close the valve between the boiler and the tank. Drain the tank until it is empty. Check all the tank plugs and fittings. Tighten as necessary. Open the valve between the boiler and tank. Water will rise to the normal height in the tank if you have an automatic fill valve (otherwise, manually refill the system).

### BOILER FLUE PASSAGES

Under normal operating conditions, with the burners properly adjusted, it should not be necessary to clean the boiler flue gas passages. However, to assure trouble-free operation, we recommend that you have the flue passages, burner adjustment, and operation of the controls checked once each year by a competent Service Technician.

Before the start of each season (or whenever system has been shut down for some time) recheck the whole system for leaks ... and recheck the boiler and vent pipe for leaks. Replace or patch any boiler seals that are faulty.

### VENT PIPE

The venting of this unit is very important and the piping should be checked at least once a season. If the vent piping shows any sign of leaking, replace it immediately.

### WATER SYSTEM

If system is to remain out of service during freezing weather, always **drain it** completely (water left in to freeze will crack the pipes and/or boiler).

### CLEANING YOUR BOILER AND BURNERS

Flue passages between sections should be examined yearly and cleaned if necessary. To clean, remove burners, pilot, and vent pipe, Remove top and front jacket panels. Remove the two screws attaching the intermediate front panel to the left and right side jacket panels. Remove the draft diverter and intermediate front panel as a unit. Carefully remove the cerafelt gasket strips. Clean passageways between sections with a flexible handle wire brush. Remove dirt from bottom of boiler and from between sections by vacuuming. Make sure all flame ports in burners are open and clear. Shake out or blow out all loose dirt in burners. Reseal seams between adjacent sections as necessary with 400° F RTV silicone sealant. Reassemble all parts. Be sure to check tightness of pilot connections and condition of burner flames after reassembly (see Figures 17 and 18). Be sure vent pipe connections to chimney are secure and no obstructions are present.

### CIRCULATOR PUMP ISOLATION VALVES

The isolation valves in the circulator pump flanges should be operated manually once or twice per year to prevent the valves from becoming stuck in the open position. Rotate the valves from the open position to the closed position and back to the open position.

### HOUSEKEEPING

- Keep boiler area clear and free from combustible materials, gasoline and other flammable vapors and liquids.
- Keep boiler area clear of debris and other materials obstructing flow of combustion and ventilation air.

## SERVICE HINTS

You may avoid inconvenience and service calls by checking these points before you call for service.

### CAUTION



#### WHAT TO DO IF YOU SMELL GAS

- Do not try to light any appliance.
- Do not touch any electrical switch; do not use any phone in your building.
- Immediately call your gas supplier from a neighbor's phone. Follow gas supplier's instructions.

If you cannot reach your gas supplier, call the fire department.

### IF YOUR SYSTEM IS NOT HEATING OR NOT GIVING ENOUGH HEAT ...

Possible Cause	What to do
Thermostat is not set correctly	Reset thermostat above room temperature
Burner is not operating properly	Check flame. If it is yellow, the burner is not getting enough air. Or, if flame is blue and noisy and seems to lift off the burner, the burner is getting too much air. Contact your service technician.
No electric power to boiler	Check over current protection. Check to be sure electric power supply circuit is "ON".
Controls out of adjustment	Reset according to instructions.
Radiators not heating	Open radiator vents to excess air. Check flow control valve (if used). It may be in closed position.
Circulating pump not running	Check over current protection. Check relay operation.
Poor electrical contact	Check all control terminals and wire joints.
Rollout switch blown	Have your service technician check heat exchanger for blockage. Replace rollout switch with exact replacement.
Spill switch blown	Have your service technician check venting system and chimney for blockage, or down draft condition. Reset spill switch.
Vent damper not operating	Consult troubleshooting guide in Effikal manual, packaged with vent damper.

### IF BURNER IS NOISY ...

Possible Cause	What to do
Gas input amount is incorrect	Contact your service technician.

### RELIEF VALVE LEAKING ...

Possible Cause	What to do
Dirt on seat	Open valve manually. Allow water to run and clear valve seat.
Water logged expansion tank	Drain tank, see instructions.

**HAVE YOUR SERVICE TECHNICIAN CHECK ANY PROBLEM YOU ARE UNABLE TO CORRECT.**

**GAS – FIRED HOT WATER BOILERS**

**– IMPORTANT –  
READ THESE INSTRUCTIONS BEFORE  
ORDERING**

All parts are listed in the following Parts List may be ordered through your nearest supplier.

When ordering parts, first obtain the Model Number from the data plate on your boiler, than determine the Part No. (not the Key No.) and the Description of each part from the following illustrations and list. Be sure to give us all this information:

- The Part No.
- The Part Description –
- The Boiler Model No.

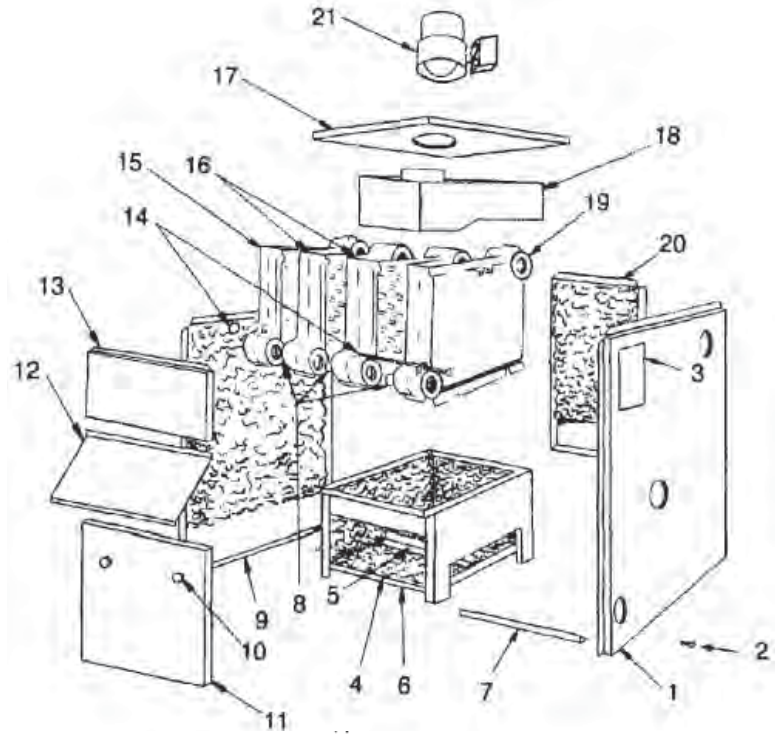

**JACKET - SECTION AND BASE PARTS**

**THIS IS A REPAIR PARTS LIST - NOT A PACKAGING LIST**

KEY NO.	DESCRIPTION	2 SECTION	3 SECTION	4 SECTION	5 SECTION	6 SECTION	7 SECTION	8 SECTION	9 SECTION
		Part No.	Part No.	Part No.	Part No.	Part No.	Part No.	Part No.	Part No.
1	Jacket, Right Side Panel	425-00-901	425-00-901	425-00-901	425-00-901	425-00-901	425-00-901	425-00-901	425-00-901
2	#10 x 1/2 Sheet Metal Screw	146-95-074	146-95-074	146-95-074	146-95-074	146-95-074	146-95-074	146-95-074	146-95-074
3	Rating Plate	146-80-901	146-80-901	146-80-901	146-80-901	146-80-901	146-80-901	146-80-901	146-80-901
4	Base Insulation - Base Sides (2)	146-14-020	146-14-130	146-14-130	146-14-130	146-14-130	146-14-130	146-14-130	146-14-130
	- Base Front	146-14-112	146-14-113	146-14-114	146-14-115	146-14-116	146-14-117	146-14-118	146-14-119
	- Base Rear	146-14-122	146-14-123	146-14-124	146-14-125	146-14-126	146-14-127	146-14-128	146-14-129
5	Base Baffle	425-00-642	425-00-643	425-00-644	425-00-645	425-00-646	425-00-647	425-00-648	425-00-649
6	Base	425-00-662	425-00-663	425-00-664	425-00-665	425-00-666	425-00-667	425-00-668	425-00-669
7	Jacket Tie Bar	425-00-652	425-00-653	425-00-654	425-00-655	425-00-656	425-00-657	425-00-658	425-00-659
8	Push Nipple	433-00-976	433-00-976	433-00-976	433-00-976	433-00-976	433-00-976	433-00-976	433-00-976
9	Jacket, Left Side Panel	425-45-900	425-45-900	425-45-900	425-45-900	425-45-900	425-45-900	425-45-900	425-45-900
10	Knob, Service Door (Pair)	137-02-513	137-02-513	137-02-513	137-02-513	137-02-513	137-02-513	137-02-513	137-02-513
11	Jacket, Service Door	425-00-912	425-00-913	425-00-914	425-00-915	425-00-916	425-00-917	425-00-918	425-00-919
12	Jacket, Int'd. Panel	425-00-812	425-00-813	425-00-814	425-00-815	425-00-816	425-00-817	425-00-818	425-00-819
13	Jacket, Front Panel	425-00-810	425-00-811	425-00-804	425-00-805	425-00-806	425-00-807	425-00-808	425-00-809
14	1/4" Tie Rod, Nut	146-05-008	146-05-001	146-05-002	146-05-051	146-05-053	146-05-005	146-05-007	146-05-009
15	Boiler Section, Left	410-00-020	410-00-020	410-00-020	410-00-020	410-00-020	410-00-020	410-00-020	410-00-020
16	Boiler Section, Middle	----	410-00-021	410-00-021	410-00-021	410-00-021	410-00-021	410-00-021	410-00-021
17	Jacket, Top Panel	425-45-842	425-45-843	425-45-844	425-45-845	425-45-846	425-45-847	425-45-848	425-45-849
18	Draft Diverter	425-00-672	425-00-673	425-00-674	425-00-675	425-00-676	425-00-677	425-00-678	425-00-679
19	Boiler Section, Right	410-00-021	410-00-021	410-00-021	410-00-021	410-00-021	410-00-021	410-00-021	410-00-021
20	Jacket, Back Panel	425-00-902	425-00-903	425-00-904	425-00-905	425-00-906	425-00-907	425-00-908	425-00-909
‡	Jacket Complete	425-00-922	425-00-923	425-00-924	425-00-925	425-00-926	425-00-927	425-00-928	425-00-929
‡	Block Assembly (19, 16, 15, 14, 8)	410-00-213	410-00-313	410-00-413	410-00-513	410-00-613	410-00-713	410-00-813	410-00-913
‡	Combustable Floor Plate	146-14-031	146-14-031	146-14-031	146-14-031	146-14-031	146-14-032	146-14-032	146-14-032
‡	Cerafelt Gasket	146-14-018	146-14-018	146-14-018	146-14-018	146-14-018	146-14-018	146-14-018	146-14-018
21	Vent Damper	118-20-04	118-20-05	118-20-06	118-20-06	118-20-07	118-20-07	118-20-07	118-20-07
‡	Base Assembly (6, 5, 4)	433-00-662	433-00-663	433-00-664	433-00-665	433-00-666	433-00-667	433-00-668	433-00-669

‡ Not illustrated

## REPAIR PARTS

**FOR USE WITH  
NATURAL GAS ONLY**

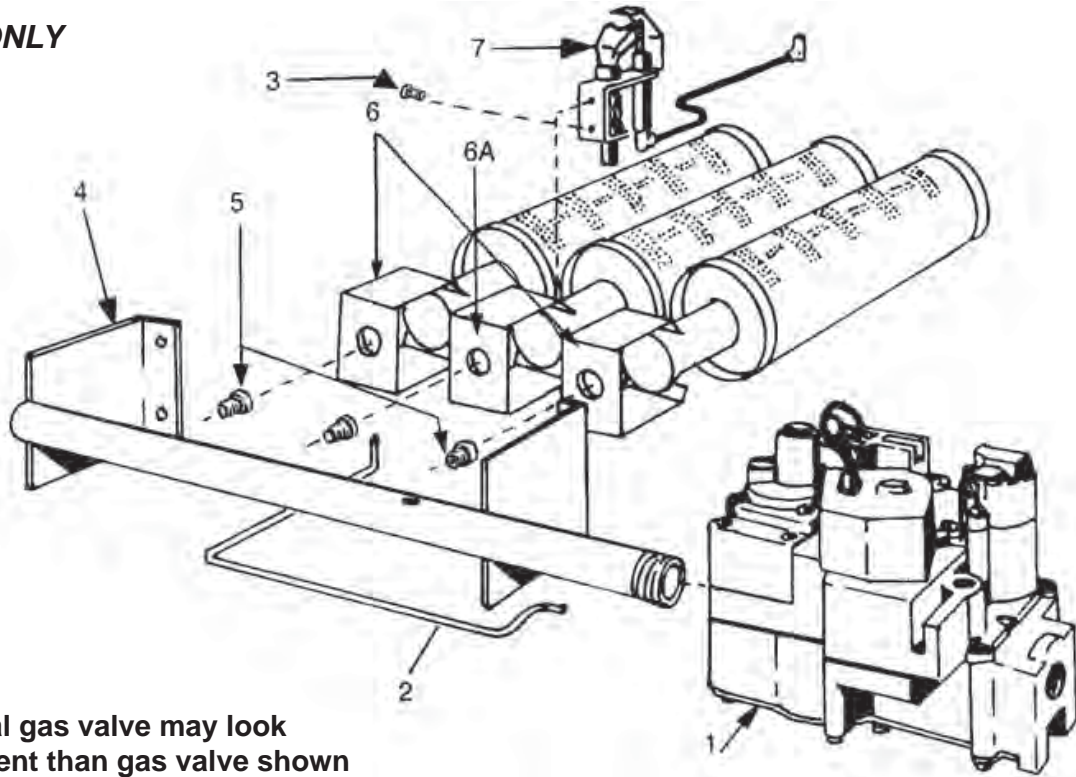

**NOTE: Actual gas valve may look different than gas valve shown**

BURNER & MANIFOLD PARTS									
<i>This is a repair parts list – NOT a packing list!</i>									
KEY NO.	DESCRIPTION	PART NUMBERS FOR							
		2 Section	3 Section	4 Section	5 Section	6 Section	7 Section	8 Section	9 Section
<b>Electronic Intermittent Ignition (Shown)</b>									
1	24 Volt Gas Valve, Nat.	14662052	14662052	14662052	14662052	14662058	14662058	14662058	14662058
	24 Volt Gas Valve, LP	14662062	14662062	14662062	14662062	14662059	14662059	14662059	14662059
2	Pilot Tube W/Fittings	43300201	43300201	43300201	43300201	43300201	43300201	43300200	43300200
3	10-32 x 1/2" Slotted Hex Head Screws	14695307	14695307	14695307	14695307	14695307	14695307	14695307	14695307
4	Gas Manifold - Nat.	14616032	14616033	14616034	14616035	14616013	14616014	14616015	14616016
	Gas Manifold - LP	14616009	14616010	14616011	14616012	14616013	14616014	14616015	14616016
5	*Main Burner Orifice - Nat.	14615041	14615041	14615041	14615041	14615042	14615042	14615042	14615042
	*Main Burner Orifice - LP	14615043	14615043	14615043	14615043	14615043	14615043	14615043	14615043
6	Main Burner Less Pilot Bracket**	---	14615532	14615532	14615532	14615532	14615532	14615532	14615532
6A	Main Burner with Pilot Bracket	14615531	14615531	14615531	14615531	14615531	14615531	14615531	14615531
7	Pilot Burner with Orifice, Nat.	14662095	14662092	14662092	14662092	14662092	14662092	14662092	14662092
	Pilot Burner with Orifice, LP	14662093	14662094	14662094	14662094	14662094	14662094	14662094	14662094
‡	Rollout Shield	42500932	42500933	42500934	42500935	42500936	42500937	42500938	42500939
<b>Alternate Parts for Continuous Pilot - 24 Volt</b>									
1	24 Volt Gas Valve Continuous Pilot - Nat.	14662051	14662051	14662051	14662051	14662060	14662060	14662060	14662060
	24 Volt Gas Valve Continuous Pilot - LP	---	14695301	14695301	14695301	14695301	14695301	14695301	14695301
7	Pilot Burner - Nat.	14662098	14662098	14662098	14662098	14662098	14662098	14662098	14662098
	Pilot Burner - LP	---	14662096	14662096	14662096	14662096	14662096	14662096	14662096
‡	Thermocouple- Nat.	14662037	14662037	14662039	14662039	14662039	14662039	14662036	14662036
	Thermocouple- LP	---	14662037	14662039	14662039	14662039	14662039	14662036	14662036

\*Requires 1 less than the number of sections.  
\*\*Requires 2 less than the number of sections.

‡ Not illustrated.  
Quantity is 1 unless otherwise noted.

**BOILER CONTROLS AND PIPING**

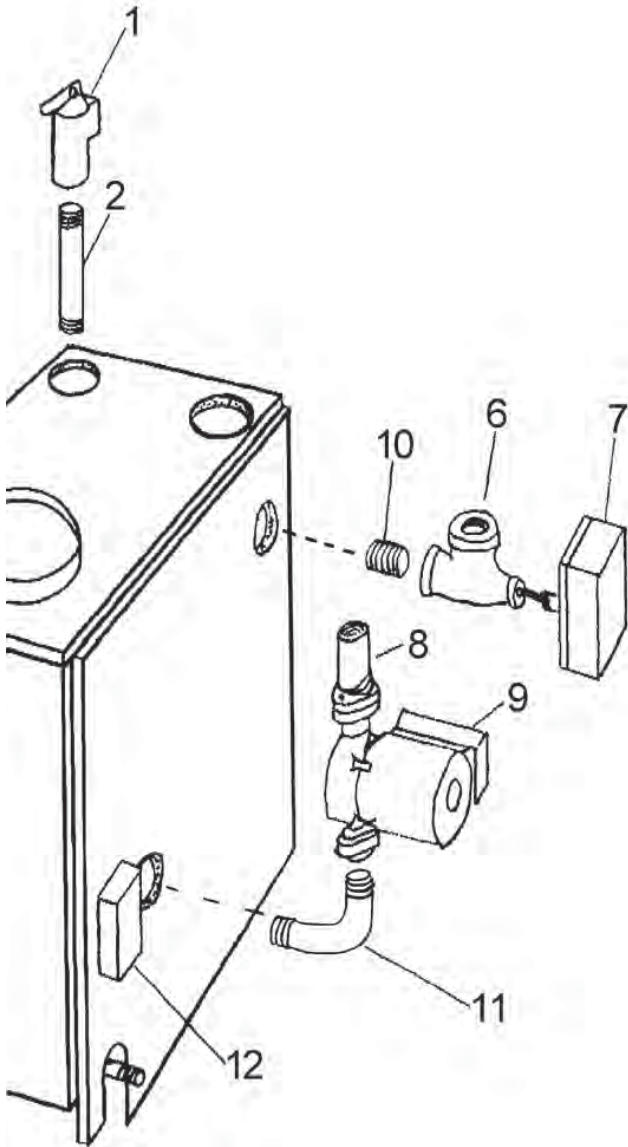

Key No.	Description	Part No.
1	3/4" ASME Relief Valve	14622011
2	3/4" x 6 1/2" Nipple	14607002
3	3a Temperature Pressure Gauge - 2" shank	1260006SP
	3b Tee, 1 1/4" x 1 1/4" x 3/4", Black Iron	PF05901
	3c Bushing, 3/4" x 1/4", Black Iron	1060002
	3d Nipple, 1 1/4" x 2 1/2", Black Iron	14607044
6	1 1/4" x 3/4" x 1 1/4" Tee	1510001
7	Aquastat Relay	1010002
‡	Isolation Valve Set- Grundfos	14626043
8	Isolation Valve Set- Taco	14626043
‡	Cast Iron Flange Set- Grundfos	14626050
‡	Cast Iron Flange Set- Taco	14626049
‡	Grundfos Pump UP15-42F Circulator	CI006.01
9	Taco Pump 007	CI-001.03
10	1 1/4" x 2 1/2" Nipple	14607044
11	1 1/4" Bent Return Nipple	14607003
12	Intermittent Pilot Control	14662070
‡	Spill Switch (36TX16-6282) 280°F	14660002
‡	Rollout Switch	14629002
‡	4" Vent Damper (with 3" Adapter)	1182004
‡	5" Vent Damper	1182005
‡	6" Vent Damper	1182006
‡	7" Vent Damper	1182007
‡	Vent Damper Operator (Motor)	1140002
‡	2 1/2" x 1 1/4" Bushing (2 Required)	14693008
‡	2 1/2" Plug	14693024
‡	2 1/2" x 3/4" Bushing	14693083
‡	1/2" Plug (3 Required)	1395003
‡	400°F Black Silicone Rubber Adhesive Sealant (10.3 oz. Cartridge)	14606020

‡ Not illustrated

**Temperature Pressure Gauge Assembly**

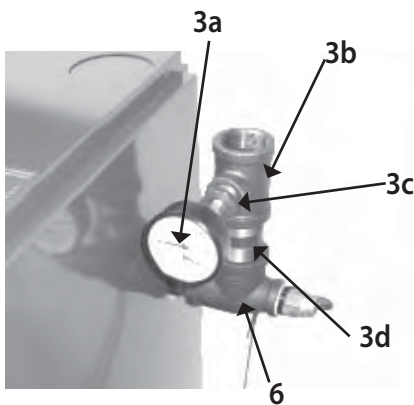











---

**ECR International, Inc.**  
2201 Dwyer Avenue,  
Utica NY 13501  
[www.ecrinternational.com](http://www.ecrinternational.com)