



EXCELSIOR Series 3

High Efficiency
Oil Fired Hot Water Boiler

INSTALLATION, OPERATION & MAINTENANCE MANUAL

Models
EXB4075
EXB4090
EXB5100
EXB6130
EXB7165



Manufactured by:
ECR International Inc.
2201 Dwyer Avenue, Utica, NY 13501
Tel. 800 325 5479
www.ecrinternational.com
PN 240013277 REV. A [12/31/2020]

EXCELSIOR OIL-FIRED CAST IRON HOT WATER BOILER

Models

EXB4075

EXB5100

EXB6130

EXB7165



Check our website frequently for updates: www.ecrinternational.com

Information and specifications outlined in this manual in effect at the time of printing of this manual. ECR International reserves the right to discontinue, change specifications or system design at any time without notice and without incurring any obligation, whatsoever.

DIMENSIONS

DIMENSIONS

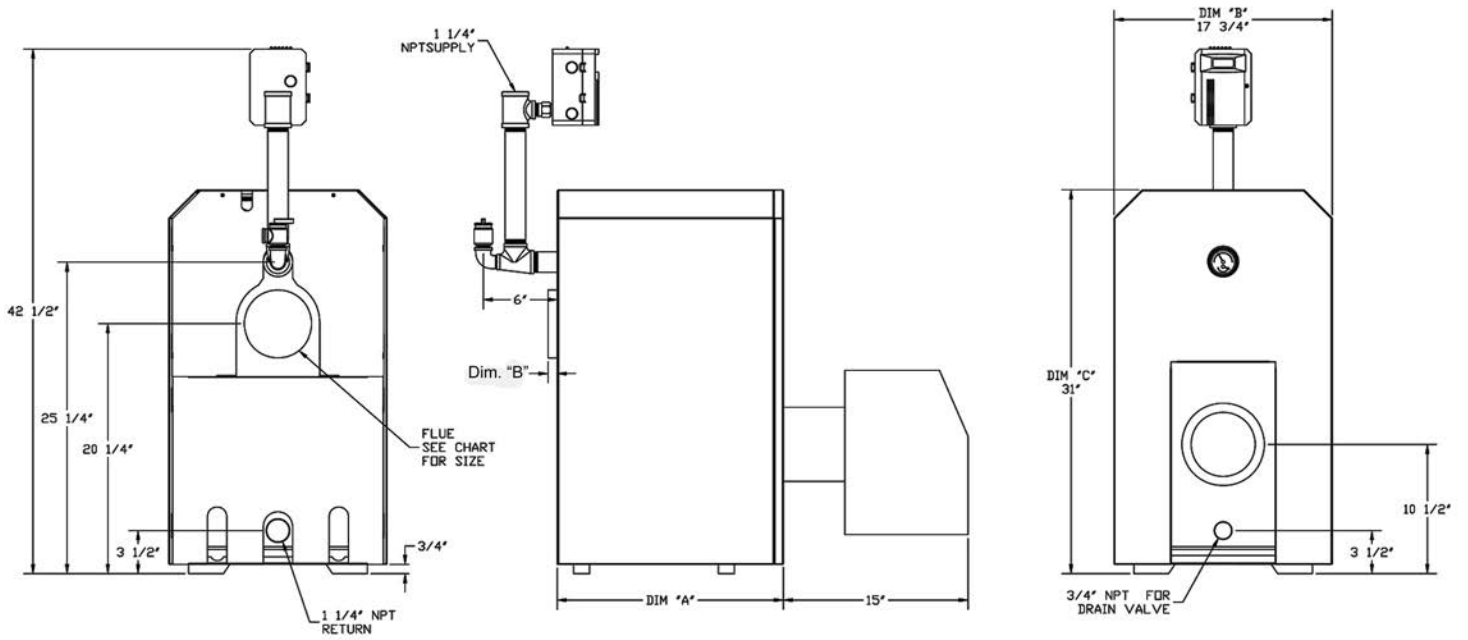

DIMENSIONS				
Sections	Flue Size Inches (cm)	Dimension "A" Inches (cm)	Dimension "B" Inches (cm)	
			Chimney Vent	Direct Vent
4	5 (13)	18 3/8 (46.6)	1 1/8 (32)	3/4 (19)
5	5 (13)	21 5/8 (54.8)	1 1/8 (32)	3/4 (19)
6	5 (13)	24 7/8 (63.1)	1 1/8 (32)	3/4 (19)
7	6 (15)	28 1/8 (71.3)	3/4 (19)	N/A

TABLE OF CONTENTS

1 - INTRODUCTION	5
2 - SAFETY INFORMATION.....	6
3 - BEFORE YOU START.....	8
4 - RATINGS & CAPACITIES.....	9
5 - LOCATING THE BOILER.....	10
6 - INSTALLATION REQUIREMENTS.....	11
7 - FRESH AIR FOR COMBUSTION.....	12
8 - BOILER ASSEMBLY	14
9 - BOILER SYSTEM PIPING.....	19
10 - HYDRONIC PIPING.....	20
11 - FUEL SUPPLY PIPING	33
12 - ANTIFREEZE IN THE SYSTEM.....	34
13 - ELECTRICAL CONNECTIONS	35
14 - CHIMNEY AND VENTING CONNECTIONS.....	36
15 - FILLING BOILER.....	39
16 - OPERATING THE BOILER - SYSTEM START-UP	40
17 - OIL BURNER, NOZZLE, & AIR SETTINGS.....	47
18 - MAINTENANCE	54
19 - OIL BOILER / BURNER CLEANING INSTRUCTIONS.....	56
20 - TROUBLESHOOTING	58
21 - EQUIPMENT AND ACCESSORIES	60

WARNING

Installations of boilers and venting shall be done only by a qualified expert and in accordance with this manual. Installing or venting a boiler or any other oil appliance with improper methods or materials could result in serious injury or death due to fire or to asphyxiation from poisonous gases such as carbon monoxide which is odorless and invisible.

NOTICE

Surface rust on cast iron sections may be attributed to manufacturing process as well as condensation during storage. Surface rust is normal and does not affect performance or life of boiler.

1. Oil Fired Boilers

Boiler is low pressure, sectional cast iron constructed and tested for maximum working pressure of 65 psi in accordance with A.S.M.E. (American Society of Mechanical Engineers) Section IV Standards for cast iron heating boilers. Capacity rated in accordance with AHRI (Hydronics Institute).

Boiler is pressure fired natural draft (chimney vented) oil fired hot water boiler comprised of cast iron sections, available with 4, 5, 6 or 7 sections. Sections are held together by metal push nipples and threaded rods.

4, 5 and 6 section boilers may be field equipped for direct vent installations with use of direct vent burner and venting kits. Direct vent instructions are covered in a separate supplemental instruction document included with direct vent venting kit.

Boiler models are capable of firing #2 fuel oil from 0.75 gph up to 1.65 gph.

Boilers include -

- Limit, 220° F maximum, operating control with integral low water cut off
- Temperature and pressure gauge
- 30 psi relief valve
- Drain valve

2 - SAFETY INFORMATION

2.1 Become Familiar With Symbols Identifying Potential Hazards.



This is the safety alert symbol. Symbol alerts you to potential personal injury hazards. Obey all safety messages following this symbol to avoid possible injury or death.

DANGER

Indicates a hazardous situation which, if not avoided, WILL result in death or serious injury

WARNING

Indicates a hazardous situation which, if not avoided, could result in death or serious injury.

CAUTION

Indicates a hazardous situation which, if not avoided, could result in minor or moderate injury.

NOTICE

Used to address practices not related to personal injury.

2.2 General

Boiler installation shall be completed by qualified agency.

WARNING

Fire, explosion, asphyxiation and electrical shock hazard. Improper installation could result in death or serious injury. Read this manual and understand all requirements before beginning installation.

WARNING

Modification, substitution or elimination of factory equipped, supplied or specified components could result in death or serious injury.

WARNING

Improper installation, adjustment, alteration, service or maintenance could result in death or serious injury.

CAUTION

Laceration, burn hazard. Metal edges and parts may have sharp edges and/or may be hot. Use appropriate personal protection equipment to include safety glasses and gloves when installing or servicing this boiler. Failure to follow these instructions could result in minor or moderate injury.

WARNING

Combustion chamber insulation in this product contains ceramic fiber material. Ceramic fibers can be converted to cristobalite in very high temperature applications. The International Agency for Research on Cancer (IARC) has concluded, Crystalline silica inhaled in the form of quartz or cristobalite from occupational sources is carcinogenic to humans (Group1). Avoid breathing dust and contact with skin and eyes. Use NIOSH certified dust respirator (N95). This type of respirator is based on the OSHA requirements for cristobalite at the time this document was written. Other types of respirators may be needed depending on the job site conditions. Current NIOSH recommendations can be found on the NIOSH website <https://www.cdc.gov/niosh/topics/silica/>. approved respirators, manufacturers, and phone numbers are also listed on this website. Wear long-sleeved, loose fitting clothing, gloves, and eye protection. Apply enough water to the combustion chamber lining to prevent dust. Wash potentially contaminated clothes separately from other clothing. Rinse clothes washer thoroughly.

NIOSH stated First Aid. Eye: Irrigate immediately. Breathing: Fresh air.

WARNING

Construction materials of appliance and products of combustion and fuel contain alumina, silica, heavy metals, carbon monoxide, nitrogen oxides, aldehydes and /or other toxic or harmful substances which can cause death or serious injury and which are known to the State of California to cause cancer, birth defects and other reproductive harm. Always use proper safety clothing, respirators and equipment when servicing or working nearby the appliance.

WARNING

Fire, Explosion, Asphyxiation, Electrical shock hazard! Flooding will result in damages such as electrical problems, corrosion, inoperative parts, mold and other unforeseen issues which can occur over time. Any equipment determined by a professional as damaged by a flood, defined as excess of water or other liquid, shall be replaced. Failure to follow these directions will result in a Hazardous Situation.

2 - SAFETY INFORMATION

FOR YOUR SAFETY READ BEFORE OPERATING

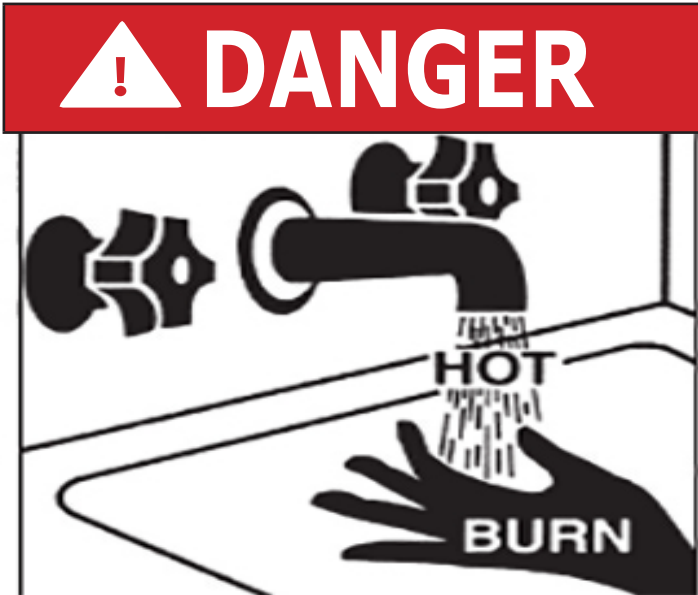

Hot Water Can Scald!

Water heated to temperature for clothes washing, dish washing and other sanitizing needs can scald and cause permanent injury.

Children, elderly, and infirm or physically handicapped persons are more likely to be permanently injured by hot water. Never leave them unattended in bathtub or shower. Never allow small children to use a hot water tap or draw their own bath.

If anyone using hot water in the building fits the above description, or if state laws or local codes require certain water temperatures at hot water taps, you must take special precautions:

- Use lowest possible temperature setting.
- Install some type of tempering device, such as an automatic mixing valve, at hot water tap or water heater. Automatic mixing valve must be selected and installed according to manufacturer's recommendations and instructions.
- Water passing out of drain valves may be extremely hot. To avoid injury:
 - Make sure all connections are tight.
 - Direct water flow away from any person.

Water Temperature Setting	1st Degree Burn Exposure Time For An Adult	2nd and 3rd Degree Burn Exposure Time For An Adult
120° F	1 minute	5 minutes
130° F	5 seconds	30 seconds
140° F	2 seconds	5 seconds
150° F	1 second	1.5 seconds
160° F	Instantaneous	0.5 seconds

Note: Warning for Infants, Children, and Elderly: Great care must be taken when exposing the aforementioned groups to warm or hot water as they can be badly burned in exposure times less than half of the time for an adult.

IMPORTANT: Read the following instructions COMPLETELY before installing!!

2.3 Installation Shall Conform To Requirements Of Authority Having Jurisdiction Or In Absence Of Such Requirements To ANSI/NFPA 31, "Installation Of Oil Burning Equipment". In Canada, Current Edition Of Canadian Standards Association CSA B139, Installation Code For Oil Burning Equipment" For Recommended Installation Practices. Such Applicable Requirements Take Precedence Over General Instructions Of This Manual.

2.4 Current Edition of American National Standard ANSI/NFPA 211 "Chimneys, Fireplaces, Vents and Solid Fuel Burning Appliances" for venting.

2.5 Where required by authority having jurisdiction, installation shall conform to Standard for Controls and Safety Devices for Automatically Fired Boilers, ANSI/ASME CSD-1.

Additional manual reset low water cutoff and manual reset high limit may be required.

2.6 Requirements for Commonwealth of Massachusetts:

Boiler installation must conform to Commonwealth of Massachusetts code 248 CMR which includes but is not limited to:

- Installation by licensed plumber or gas fitter.

3.1 Installation and Operation

1. Do not operate unit if any control, switch, components or devices have been underwater or subject to water damage.
2. Before servicing, allow boiler to cool. Always shut off any electricity and oil supply to boiler when working on it.
3. Inspect oil line and connections for leaks.
4. Verify oil burner nozzle is proper size. Over-firing could result in early failure of boiler sections, and result in a potentially dangerous situation.
5. Never vent boiler into enclosed space. Always vent to the outside. Never vent to another room or inside a building.
6. Verify adequate air supply for complete combustion.
7. Relief valve automatically lifts open when system pressure exceeds 30 psi. Before installing relief valve read manufacturer's instructions. Pipe relief valve to a safe location. Check with authorities having jurisdiction.
8. Consider system total water volume, temperature, initial fill pressure and arrangement when sizing and installing expansion tank. Improperly installed and sized expansion tank may result in frequent lifting of relief valve or other heating system problems. Follow expansion tank manufacturer guidelines for installation, and sizing.
9. Boiler manufacturer recommends initial fill pressure of 10-12 psi. For higher fill pressures increase expansion tank's air charge to match fill pressure.
10. Purging heating system of air and gases is critical for proper circulation and quiet performance. Once the air is purged, for boiler installations using float type vents, air vents should be closed for normal operation. If air is heard or noticed by loss of heat, purge system and open vents for short period of time.

3.2 Prior To Installing The Boiler

- Verify you have selected right size boiler with proper capacity. AHRI rating of boiler selected should be greater than or equal to calculated peak heating load (heat loss) for building or area(s) served by boiler and associated hot water heating systems. Use heat loss calculations based on approved methods. See Table 1.
- Boiler must be supplied with proper oil supply and oil piping, sufficient fresh combustion air, and suitable electrical supply.
- Connect boiler to suitable venting and piping systems adequate to distribute heating load.
- Installation is not complete unless pressure relief valve is installed in 3/4" tapping located in supply piping.
- Thermostat must be properly located and installed
- Failure to pipe boiler correctly may result in excessive noise or other related problems.

Existing Water System Evaluation

A good system will prevent oxygen contamination of boiler water.

1. Causes of oxygen contamination may be:
 - A. Addition of excessive make up water as a result of leaks.
 - B. Absorption through open tanks and fittings.
 - C. Oxygen permeable materials in the distribution system.
2. To insure long product life, oxygen sources must be eliminated.

Take the following measures:

- A. Repair system leaks.
- B. Eliminate open tanks from the system.
- C. Eliminate and/or repair fittings which allow oxygen absorption.
- D. Use non-permeable materials in the heating system.

4 - RATINGS & CAPACITIES



Table 1 - RATINGS & CAPACITIES

OIL-FIRED HOT WATER BOILERS

Number of Sections	Firing Rate [GPH]	Input [Mbh]	Heating Capacity [Mbh]	Net AHRI Rating [Mbh]	*MAWP Water [psi]	AFUE [%]	Min. Relief Valve Capacity [Mbh]	Max. Water Temp [°F]	Chimney Liner Size Round [Inches]	Chimney Liner Size Square [Inches]	Flue Size [Inches]
4	0.75	105	92	80	65	87.0	140	250	6	6¾	5
4	0.90	126	110	96	65	86.0	140	250	6	6¾	5
5	1.00	140	123	107	65	87.0	175	250	6	6¾	5
6	1.30	182	160	139	65	87.0	210	250	6	6¾	5
7	1.65	231	202	176	65	87.0	245	250	7	6¾	6

GPH = U.S. Gallons per Hour

Mbh = 1000 Btu (British thermal units) per hour.

psi = Pounds per square inch

*MAWP = Maximum allowable working pressure. This low pressure oil fired hot water boiler is constructed and hydrostatically tested for maximum working pressure of 65 psi in accordance with the latest revision of the A.S.M.E. (American Society of Mechanical Engineers) Boiler and Pressure Vessel Code Section IV Standards for heating boilers.

AFUE= Annual Fuel Utilization Efficiency

Heating Capacity and AFUE based on 13.1% CO₂ (13.5% CO₂ at 0.90 GPH, 13.2% CO₂ at 1.65 GPH), -0.02" w.c. draft in breech, and # 1 smoke or less. Testing is done in accordance with U.S. DOE (Department of Energy) test procedure.

Heating Capacity indicates amount of heat available after subtracting losses up the stack. Remaining heat is available to heat water. Small portion is heat from jacket and surfaces of boiler and this heat stays in structure. Net AHRI rating represents portion of remaining heat applied to heat radiation or terminal units (i.e. finned tube baseboard, cast iron radiators, radiant floor, etc.). Difference between Heating Capacity and Net AHRI Rating, called piping and pickup allowance, establishes reserve for heating volume of water in system and offsetting heat losses from system piping. Net AHRI ratings shown are based on piping and pickup factor of 15% in accordance with AHRI Standard as published by Hydronics Institute.

Net AHRI rating of boiler selected should be greater than or equal to calculated peak heating load (heat loss) for building or area(s) served by boiler and associated hot water heating systems. Consult manufacturer before selecting boiler for installations having unusual piping and pickup requirements.

5 - LOCATING THE BOILER

⚠ WARNING

Fire hazard. Do not install on carpeting. Failure to follow these instructions could result in death or serious injury.

1. Boiler is suitable for installation on combustible flooring. Do not install boiler on carpeting.
2. Locate boiler in front of final position before removing crate.
3. Locate unit so vent pipe connection to chimney will be short and direct.
4. For basement installation, provide solid elevated base, such as concrete, if floor is not level, or if water may be encountered on floor around boiler.
5. Provide recommended service clearance, if applicable, as follows:
 - **Clearance from Jacket Front Panel**
24" for servicing burner
 - **Clearance from Jacket Side Panels**
24" for burner swing door, if opened fully with burner mounted, otherwise 2" with burner removed.
 - **Clearance From Jacket Rear Panel**
24" minimum for rear smoke box cleaning. (Note: this dimension will also be controlled by horizontal to vertical to horizontal smoke pipe arrangement. See Figure 1.
6. Minimum clearances to combustible material see Figure 1 and Table 2.

7. Fresh air for combustion and ventilation must be available at boiler. Ventilating and combustion air must enter boiler room without restrictions.
8. Installation shall conform to requirements of authority having jurisdiction or in absence of such requirements in United States, follow NFPA 31 Installation of Oil Burning Equipment.
9. Clearance to venting is for single wall flue pipe. If Type L vent is used, clearance may be reduced to minimum required by vent pipe manufacturer.

Table 2 - BOILER CLEARANCES

Unit	Combustible Clearance	Accessibility, Cleaning, and Servicing
Top	12" (32 cm)	24" (61 cm)
Right Side	2" (5 cm)	24" (61 cm)
Left Side	2" (5 cm)	24" (61 cm)
Floor	Combustible	No Requirement
Front	17" (43 cm)	24" (61 cm)
Back	9" (23 cm)	24" (61 cm)
Flue	9" (23 cm)	9" (23 cm)

All distances measured from the boiler jacket or flue.

Figure 1 - Clearances to Combustible Construction

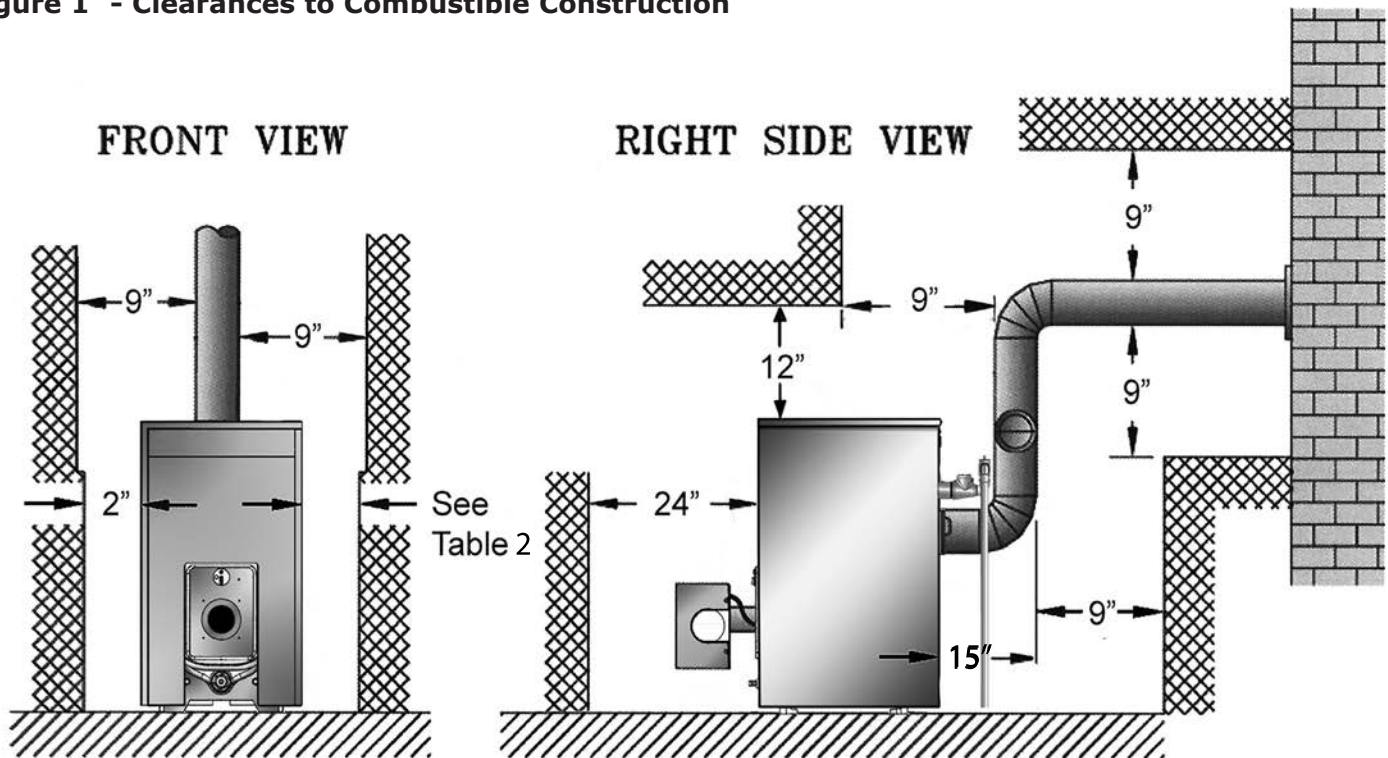

6 - INSTALLATION REQUIREMENTS

Figure 2 - General Requirements For A Typical Installation

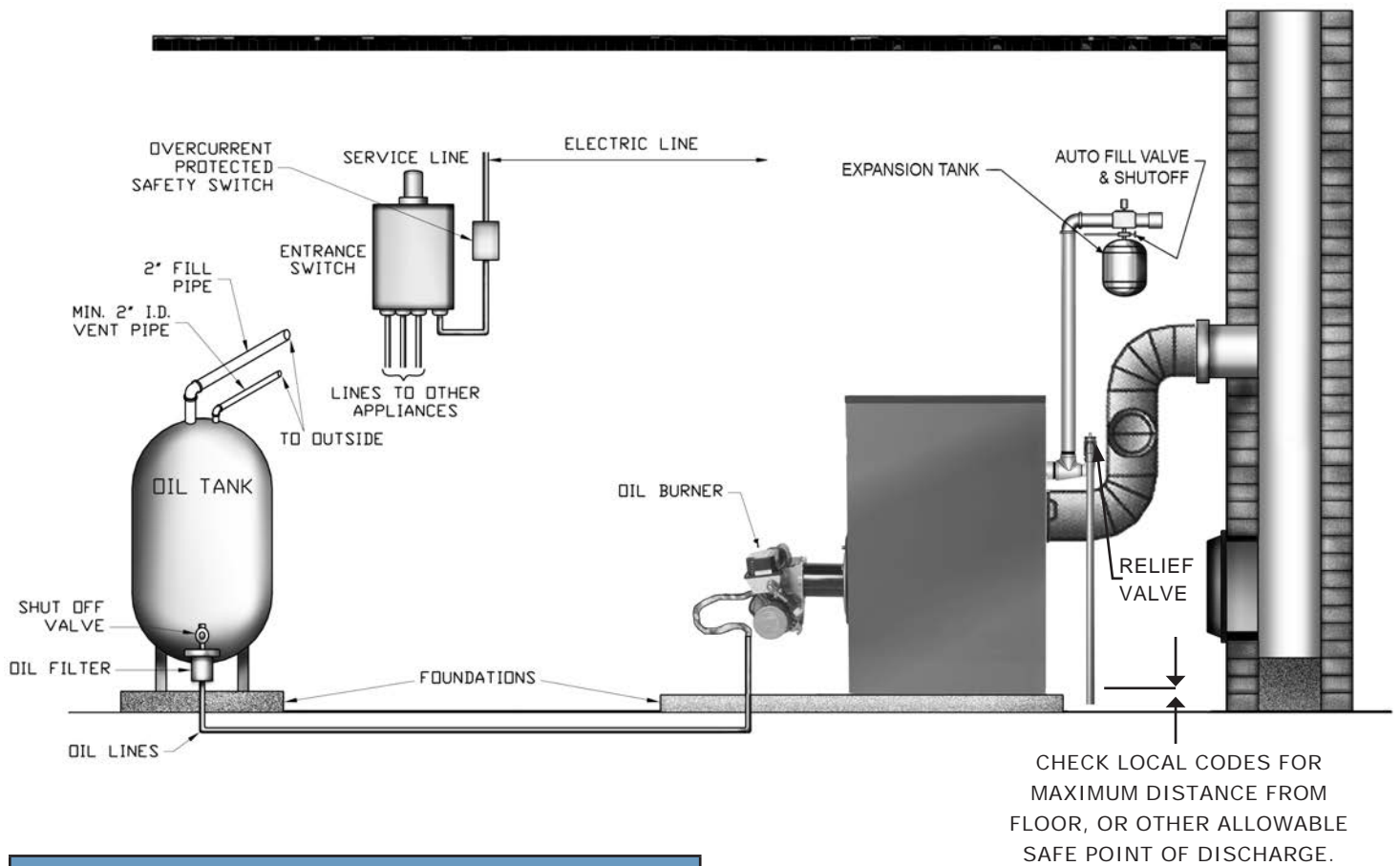

NOTICE

Shut off manual fuel supply valve if burner is shut down for extended period of time.

7 - FRESH AIR FOR COMBUSTION

WARNING

Asphyxiation, fire hazard. Do not obstruct air openings to combustion area. Follow instructions below, to maintain adequate combustion air.

NOTICE

Install outside air intake if used with a fireplace or kitchen or bathroom exhaust fan. These devices rob boiler and water heater of combustion air.

1. Determine volume of space (boiler room). Rooms communicating directly with the space in which appliances are installed, through openings not furnished with doors, are considered a part of the space. $\text{Volume (ft}^3\text{)} = \text{Length (ft.)} \times \text{Width (ft.)} \times \text{Height (ft.)}$
2. Determine total input of all appliances in the space. Add inputs of all appliances in the space and round the result to the nearest 1000 BTU/hr.
3. Determine type of space. Divide Volume by total input of all appliances in space. If the result is greater than or equal to 50 ft³/1000 BTU/hr, then it is considered an **unconfined space**. If the result is less than 50 ft³/1000 BTU/hr, then the space is considered a **confined space**.
4. When a boiler is located in an unconfined space of a conventionally constructed building, fresh air infiltration through cracks around windows and doors normally provides adequate air for combustion and ventilation.
5. Provide outdoor air for boiler located in a confined space or an unconfined space in a building of unusually tight construction. Outdoor air may be provided with the use of two permanent openings which communicate directly or by duct with the outdoors or spaces (ventilated crawl or attic) freely communicating with the outdoors. Locate one opening within 12 inches of top of space. Locate remaining opening within 12 inches of bottom of space. Size each opening per the following:

A. Direct communication with outdoors:

Minimum free area of 1 square inch per 4,000 BTU per hour input of all equipment in space.

B. Vertical Ducts: Minimum free area of 1 square inch per 4,000 BTU per hour input of all equipment in space. Duct cross-sectional area shall be same as opening free area.

C. Horizontal Ducts: Minimum free area of 1 square inch per 2,000 BTU per hour input of all equipment in space. Duct cross-sectional area shall be same as opening free area.

Alternate method for boiler located within confined space: Use indoor air if two permanent openings communicate directly with additional space(s) of sufficient volume such that the combined volume of all spaces meet criteria for unconfined space. Size each opening for minimum free area of 1 square inch per 1,000 BTU per hour input of all equipment in spaces, but not less than 100 square inches.

6. Louvers and Grilles of Ventilation Ducts

- A. All outside openings should be screened and louvered. Screens used should not be smaller than 1/4 inch mesh. Louvers will prevent the entrance of rain and snow.
- B. Free area requirements need to consider the blocking effect of louvers, grilles or screens protecting the openings. If the free area of the louver or grille is not known, assume wood louvers have 20-25% free area and metal louvers and grilles have 60-75% free area.
- C. Louvers and grilles must be fixed in the open position, or interlocked with the equipment to open automatically during equipment operation.

Figure 3 - Air Openings For Boiler Located In Confined Space (Utility Room)

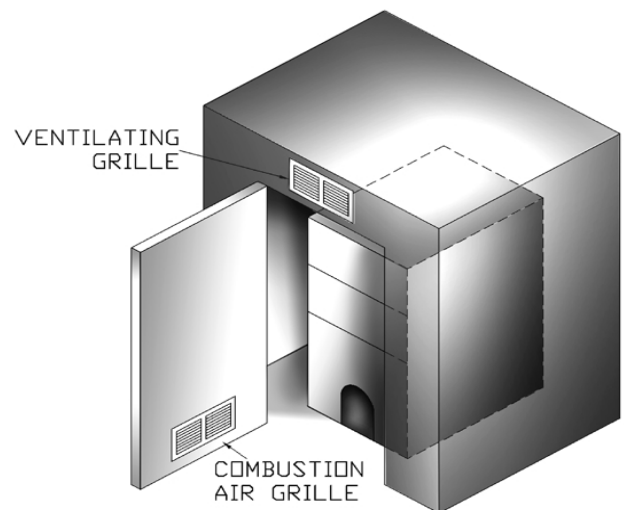

7 - FRESH AIR FOR COMBUSTION

Fresh Air Duct Capacities For Ducts Supplying Fresh Air To Boiler In Tightly Constructed Houses

Table 3 - FRESH AIR DUCT CAPACITIES THROUGH LOUVERS			
Fresh Air Duct Size	¼" Mesh Screen	Wood Louvers	Metal Louvers
	(Btuh)*	(Btuh)*	(Btuh)*
3 ½" x 12"	144,000	36,000	108,000
8" x 8"	256,000	64,000	192,000
8" x 12"	384,000	96,000	288,000
8" x 16"	512,000	128,000	384,000

**Btuh = British Thermal Units per hour based on opening covered by ¼" mesh screen, wood louvers, or metal louvers.*

Figure 4 - Fresh Air Openings

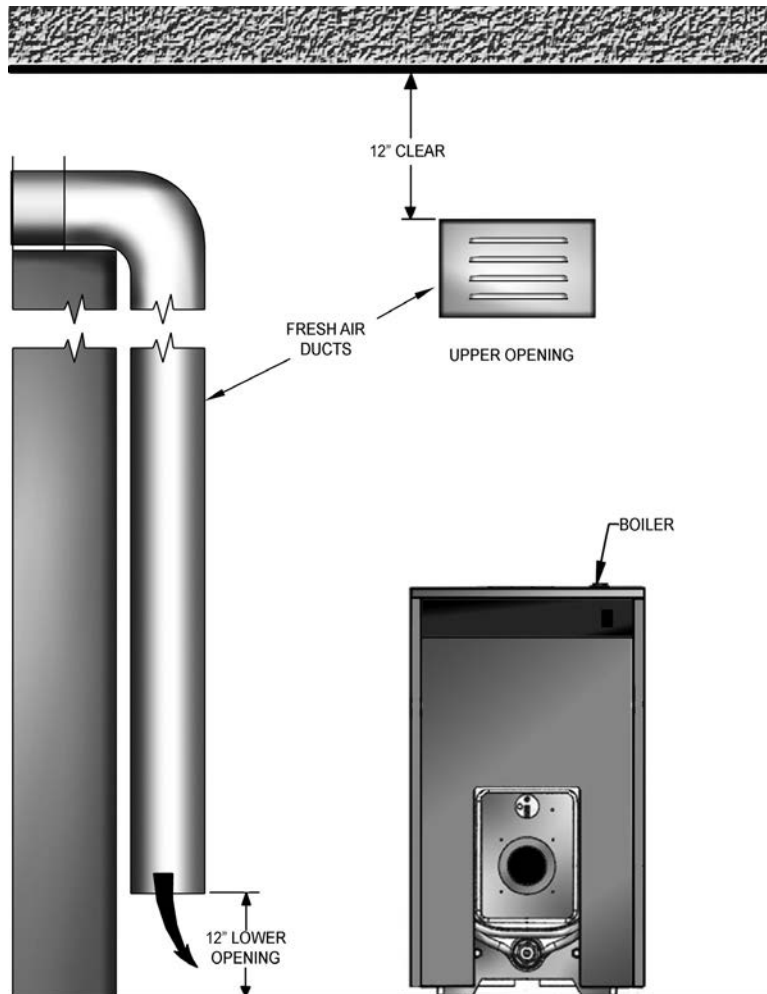

8 - BOILER ASSEMBLY

1. Remove Crate
 - A. Remove all fasteners at crate skid.
 - B. Lift outside container and remove all other inside protective spacers and bracing. Remove burner and miscellaneous parts boxes.
2. Remove Boiler from skid. Boiler is secured to base with 4 screws. Remove all securing hardware.
3. Move boiler into permanent position by sliding or walking into place.
4. Do not drop boiler. Do not bump boiler jacket against floor.
5. Open burner swing door.
 - A. Loosen and remove non-hinged side latching hardware.
 - B. Remove hinged side latching hardware.
 - C. Door can be swung to full open position approximately 90 to 120 degrees with the burner mounted providing there is 22" of clearance to the adjacent wall.

NOTICE

Burner door may come off hinges if lifted when opened.

If reduced clearance prevents door from opening fully, one of the following can provide full access:

- Burner can be removed to allow full rotation of door. Door with burner mounted can be lifted off hinges and set aside during servicing.
- Door mounting hardware is reversible from left side hinge (as shipped) to right side hinge. To reverse hinge arrangement. See Figure 5.
- Lift door off mounting eye bolts and set aside. Remove mounting eye bolts from left side. Move door mounting eye bolts to right side. Tighten both sets of hardware. Lift door and place integral cast hinge pins on door into slotted mounting bracket holes.

Recommend hinges be on same side as flexible oil line in order to swing door open.

6. Inspect Swing door insulation and rope gasket.
 - A. Inspect fiber rope located on swing door. Evenly distribute rope around perimeter of door groove do not bunch or overhang. There must not be a gap where two ends of rope meet. Repair or replace if rope is damaged or if there is gap between ends.
 - B. Inspect burner swing door insulation for damage.
 - C. Combustion chamber and raised portion between 2nd and 3rd pass flue ways make an impression in door insulation as designed.
 - D. Do not close and secure door at this time.

Figure 5 - Reversible Hinge

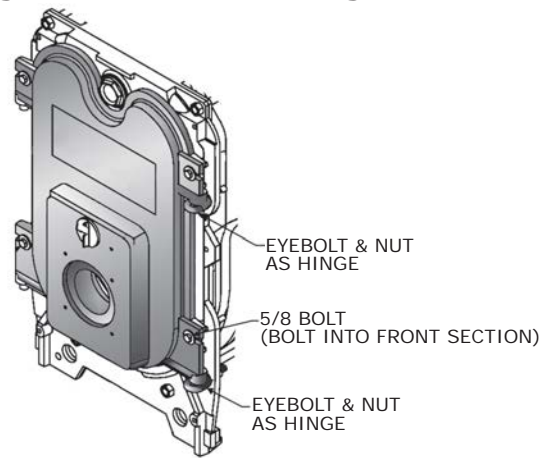

NOTICE

For purpose of these instructions, all pipe connections shall use pipe dope or Teflon tape to assure water tight connections unless otherwise instructed. Steps 6 thru 16, Figure 10, Page 15.

7. Open accessory carton and remove contents. Identify components using illustrations throughout this section applicable to your installation.
8. Locate 1-1/4" x 6" pipe nipple. Thread thru insulation slot into supply port in rear of boiler. Locate 1-1/4 x 3/4 x 1-1/4 tee and assemble onto nipple. Verify connections are tight with outlet facing directly up. See Figure 6.
9. Locate 1-1/4" x 10" nipple. assemble onto tee. See Figure 6

Figure 6 - Supply Piping

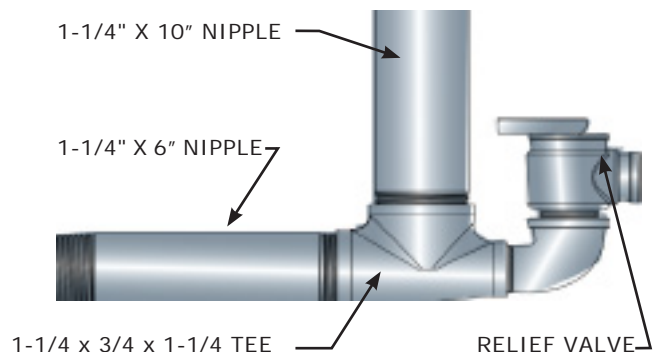

8 - BOILER ASSEMBLY

NOTICE

Do not install valve between boiler and controls manifold or relief valve.

10. Locate cast 1-1/4 x 1-1/4 x 3/4 tee and assemble on 1-1/4" x 10" nipple with 3/4" tapping facing toward front of boiler and joint is water tight.
11. Install Limit control mounting plug in upper 3/4"NPT port facing front. See Figure 7.
12. Install Limit control & harness assembly. Loosen mounting screw on bottom of limit control.
 - A. Mount control on mounting plug and tighten screw to secure control. See Figure 7.
 - B. Confirm thermal limit/LWCO sensor bulb is fully inserted to bottom of control well in top of rear boiler section and secured with grommet. See Figure 8.
 - C. Route thermal limit/LWCO sensor wire to control and connect. See Figure 10, and Figure 15.

Figure 7 - Control On Mounting Plug w/Screw

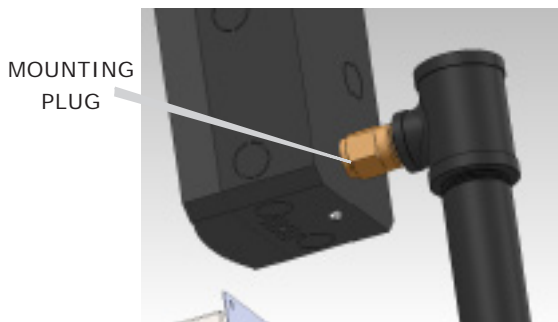

⚠ WARNING

Burn and scald hazard. Relief valve could discharge steam or hot water during operation. Check local codes for maximum distance from floor or allowable safe point of discharge. Installation of relief valve shall be consistent with ANSI/ASME Boiler and Pressure Vessel Code, Section IV.

13. Install Relief Valve. See Figures 6 and 9.
 - A. DO NOT pipe in area where freezing can occur. DO NOT install shutoff valves, plugs or caps.
 - B. Locate 3/4"NPT x 90° street elbow. Install elbow using 3/4" NPT tapping in supply piping. Install elbow with outlet facing directly up. Install relief valve with outlet facing horizontally.
 - C. Pipe discharge of relief valve. Installation of relief valve must be consistent with ANSI/ASME Boiler and Pressure Vessel Code, Section IV

Figure 8 - Grommet

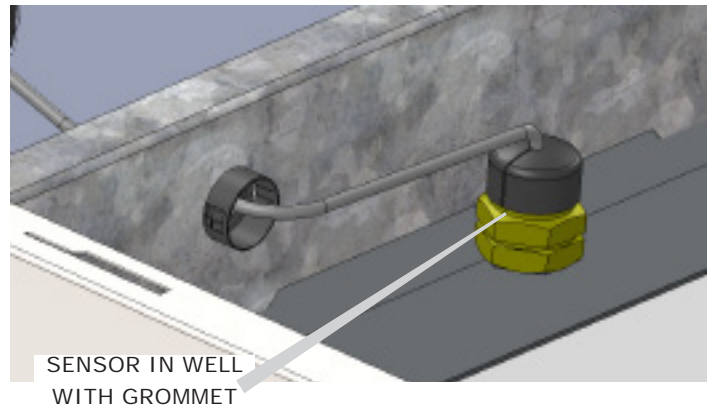
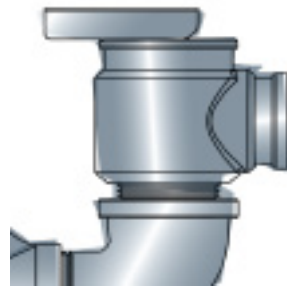

Figure 9 - Relief Valve



14. Check installation of liners and baffles (Not all models). See Table 4.
 - A. Check oval (4 section) or V-shaped (6 and 7 section) liner. See Figures 11 and 12. Liner should be flush with front edge of heat exchanger fins.
 - B. Flue way baffles (4, 5, 6 section only) are factory installed in 3rd pass. 4 section boiler uses twelve Type A baffles, six left hand and six right hand. 5 and 6 section boiler uses two Type B baffles. Insure baffles are inserted in flue way such that position tab touches casting between 2nd and 3rd Pass flue way. See Figures 13a, 13b, 13c.

Efficiency of boiler is based on insertion of flue way baffles in 4, 5 and 6 section units. Baffles will generate lower gross stack temperatures entering chimney. This has the potential under certain operating conditions to cool flue gases below dew point, creating condensation on interior chimney and chimney connector surfaces. Remove baffles to increase stack temperature if there are any signs of condensation in chimney or chimney connector. Removing baffles alone may not address condensation depending on other boiler and heating system operating conditions.

NOTICE

Flue gas condensate is corrosive, which requires special consideration and must be addressed immediately.

Figure 10 - Supply Piping and Control Assembly

NOTICE

Do not install valve between boiler and controls manifold or relief valve.

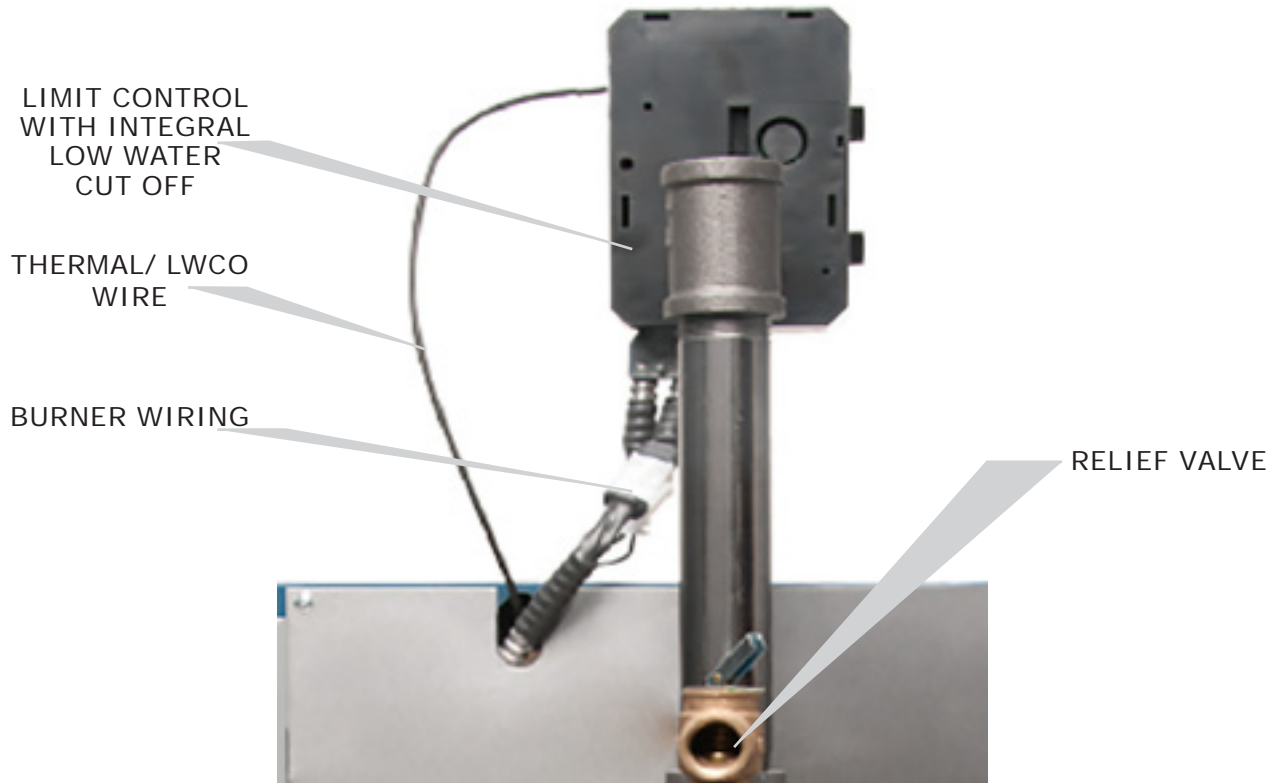

BACK OF BOILER

8 - BOILER ASSEMBLY

Figure 11 - Oval Liner



Figure 12 - V-Shaped Liner



Figure 13a - Type B Third Pass Baffles (5 and 6 Section)

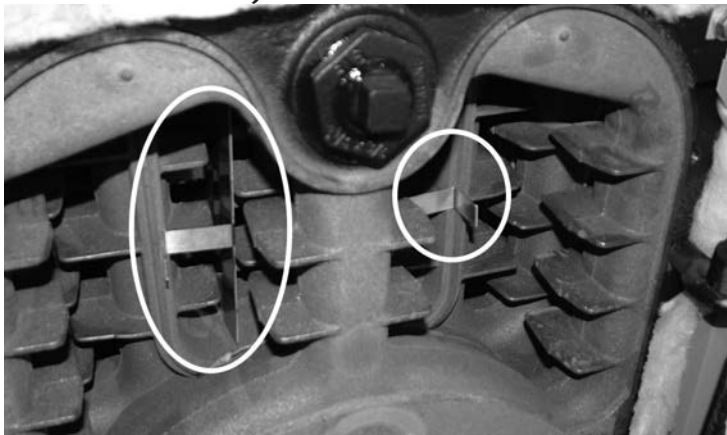

15. Connect Field Wiring. See "13 - Electrical Connections".
 - A. Route wire harness from burner to Limit control through rear jacket panel. See Figure 10. Connect moxex plug on burner wire harness to its receptacle on limit control.
 - B. If optional manual reset high temperature limit is not used, ensure supplied jumper is installed.
 - C. Connect the wiring harness from limit control to circulator. See Figure 14.
 - D. 120 volt power supply field wiring connects to limit control. Provide appropriate overcurrent protection and service disconnect switch.
 - E. Wire power supply. Connect green wire to grounding lug. When installing wiring through hole in Limit, use anti-abrasion cable clamp. Connect black "hot" wire to L1 of terminal block, white "N" wire to L2 of terminal block.
16. Install top panel. Place on top of side panels. Position tabs in top panel into slots in side panels. Push top panel toward back of boiler. Install rear panel screws.
17. Install drain valve. Install drain valve with hose connection facing right or left. This allows clearance for swing door to open and close with drain and hose attached. Verify connection is water tight. See Figure 16.
18. Close burner swing door.
 - A. Use one hand to hold door in position by applying pressure directly to door while re-installing securing hardware with your opposite hand. Always install non-hinged side latching hardware first, then install hinged side hardware. Apply additional pressure while hand tightening hardware as far as possible, then release pressure.

Figure 13b - Type A Third Pass Baffles (4 Section)



Table 4 - BAFFLES & LINERS

Model	Liner	Liner Length	Baffle Type	Baffle Length	Baffle Quantity
4	Oval	4"	A	9"	6 Left/6 Right
5	NONE	NA	B	12"	2
6	V SHAPE	12"	B	15"	2
7	V SHAPE	14"	None	N/A	N/A

Figure 13c - Baffle Types A and B

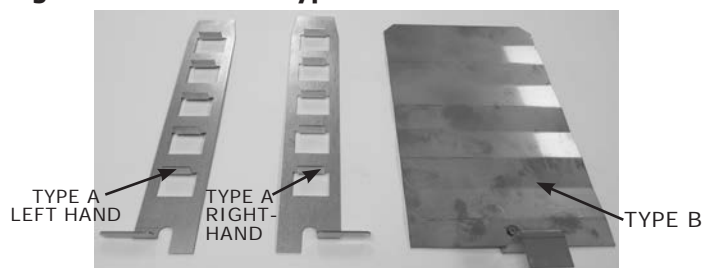
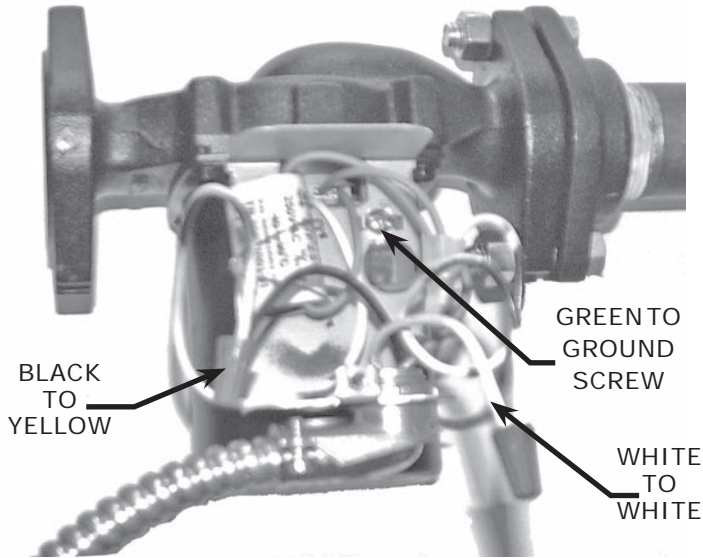

Figure 14 - Circulator Wiring



NOTICE

Ensure all conduit is secured to prevent contact with flue pipe

- B. Use hand wrench to tighten door hardware and start with non-hinged side. Use alternating tightening method from non-hinged side to hinged side to tighten door equally until sealed without applying excessive torque. Never tighten hinged side flange bolt first or tighten either piece of hardware 100% without using alternating tightening method described above.

NOTICE

When securing burner swing door, make sure door is drawn-in equally on both sides.

Failure to follow the prescribed procedure could cause thread damage to casting or a leak in the door seal. If hinged side is tightened before the unhinged side, the hinged side of door cannot be drawn to provide an air-tight seal. Applying excessive torque will only cause thread damage.

Figure 15 - Limit Control Wiring

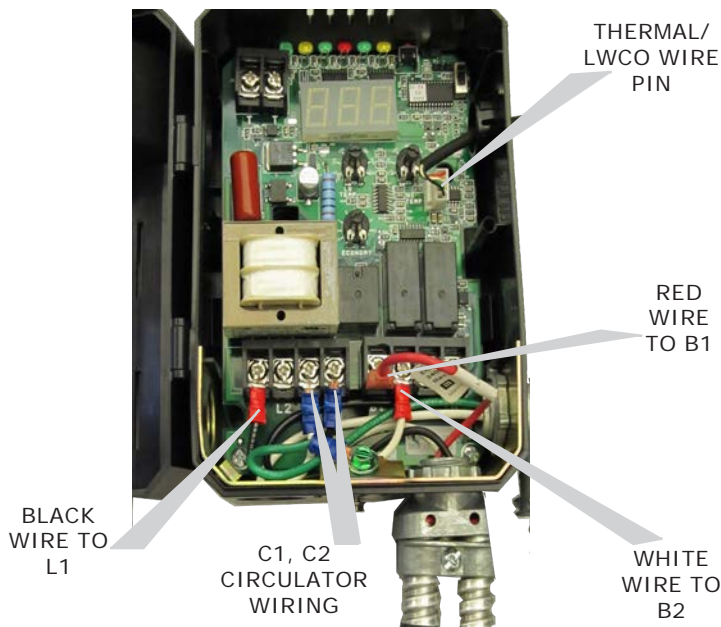

19. Install oil burner

- Check oil nozzle in burner for size, angle and type, inspect electrode settings, check head setting, check air band and air shutter settings. **See** "Oil Burner, Nozzle, & Air Settings".
- DO NOT install burner without gasket. Place oil burner gasket on face of burner swing door with 4 burner flange bolts installed part way.
- Align round part of key hole slots of burner flange with burner door bolts. Turn burner to lock in place.
- Tighten all 4 hex nuts using diagonal sequence.
- Plug burner power cord into burner harness.
- Attach flexible oil hose included in parts box.

Figure 16 - Drain Valve

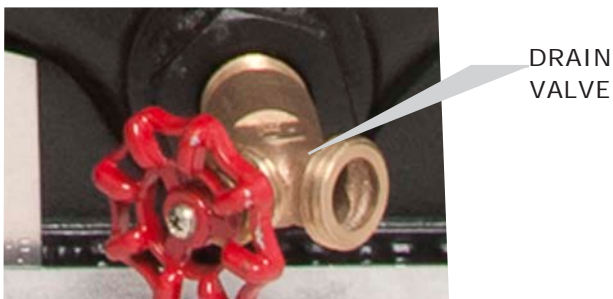

9.1 Connect System Supply And Return Piping To Boiler

Connect system supply and return piping to correct boiler fittings.

Size system circulator to supply sufficient flow (GPM) to allow 20°F temperature differential in system. Connect circulator harness to circulator per Figure 14 and furnished wiring diagram.

When sizing system circulator, use single most restrictive zone to determine maximum pressure drop.

1. Boiler used in connection with refrigeration systems, install boiler so chilled medium is piped in parallel with heating boiler using appropriate valves to prevent chilled medium from entering boiler. See Figure 28.
2. If boiler is connected to heating coils located in air handling units exposed to refrigerated air, equip boiler piping with flow control valves to prevent gravity circulation of boiler water during operation of cooling system.
3. Limit control includes low water cutoff function, sensing water level at control well in top of the rear boiler section. Periodic inspection and testing is necessary per instructions provided with limit control.
4. When installation of boiler is for new heating system, install all radiation units (panels, radiators, baseboard, or tubing) and supply and return mains. After heating system piping and components have been installed, make final connection of system piping to boiler. Recommend mount circulating pump on supply side piping, such that it pumps away from expansion tank.
5. Hot water boiler installed above radiation level must be equipped with low water cut off device. This boiler is factory equipped with low water cutoff. Periodic inspection is necessary, per manufacturer's specific instructions.
6. When connecting cold water supply to pressure reducing valve, make sure clean water supply is available. When water supply is from well or pump, install sand strainer at pump.

9.2 Bypass Piping

See Piping Diagrams for illustrations for this section.

Bypass piping may be required for applications listed below. Failure to do so may cause damage due to thermal shock and sustained condensation within the boiler.

Protect boiler from sustained operation of return water temperatures lower than 130°F (54C). Occasionally, temperatures as low as 70°F (21C) may return back to boiler when a zone that has not been activated for some time is opened. However, most residential systems with finned-tube (aluminum-copper) baseboard radiation contain low volume of water and will not adversely affect boiler. Systems with finned-tube baseboard radiation typically do not require bypass.

Bypass piping details shown in piping diagrams must be used for any one of following conditions:

- All large water content systems, including cast iron standing radiators, cast iron baseboard, converted two-pipe steam systems, converted gravity circulation systems and other similar systems.
- Any system, including finned-tube baseboard, with priority domestic hot water zone.

Install ¾ inch bypass line as shown in piping diagrams for systems identified above.

Bypass valve cannot protect boiler from sustained condensing operation for low temperature applications such as radiant floor heating. These types of system require active controls that prevent return of cold return water to boiler.

Refer to Radiant Professional's Alliance (RPA) www.radiantprofessionalsalliance.org for piping recommendations for non-condensing boiler applications.

Figure 17 - Standard Near Boiler Piping

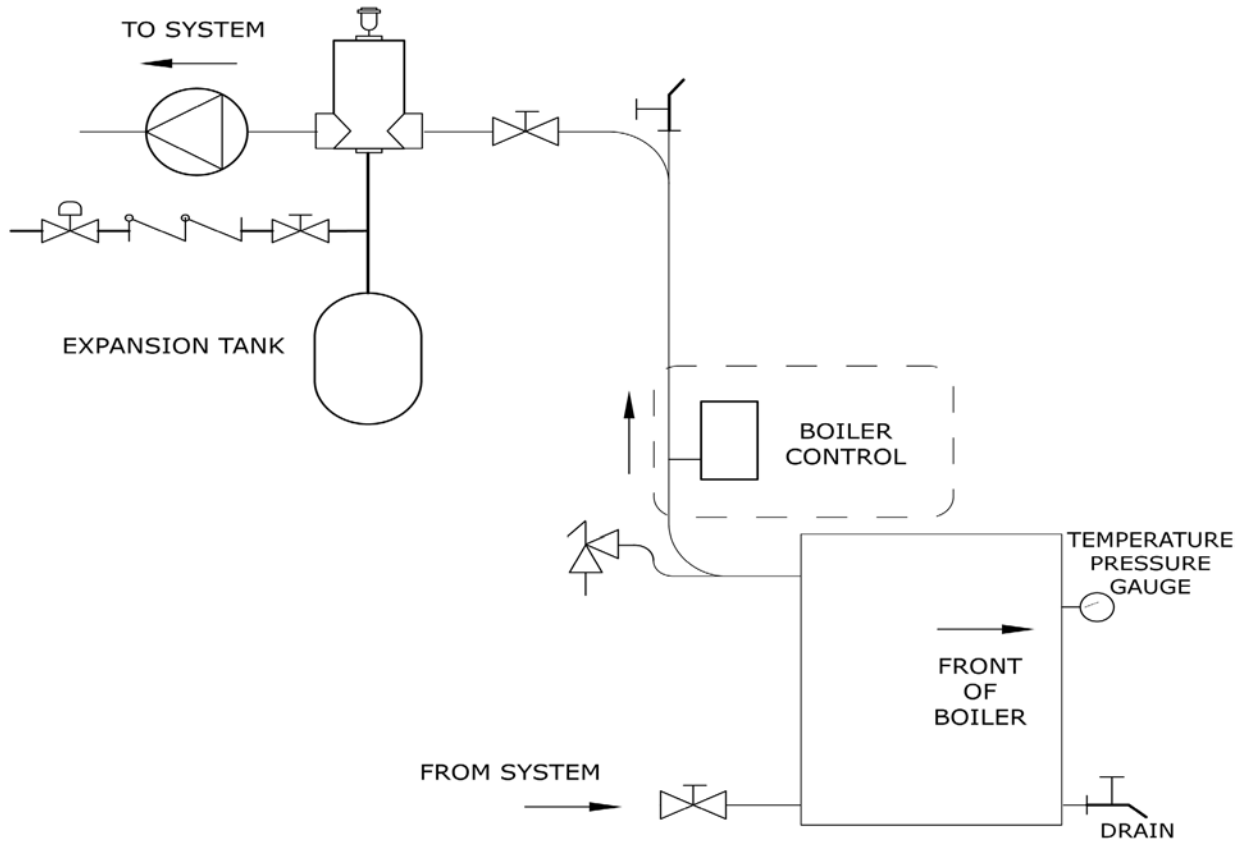

Piping Diagram Legend

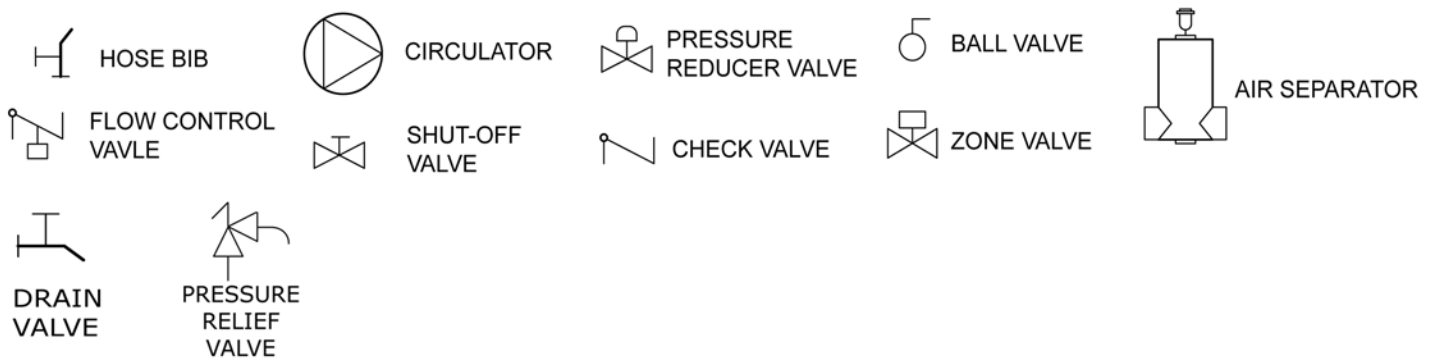

10 - HYDRONIC PIPING

Figure 18 Piping And Wiring Single Zone System With Domestic Hot Water DHW Priority

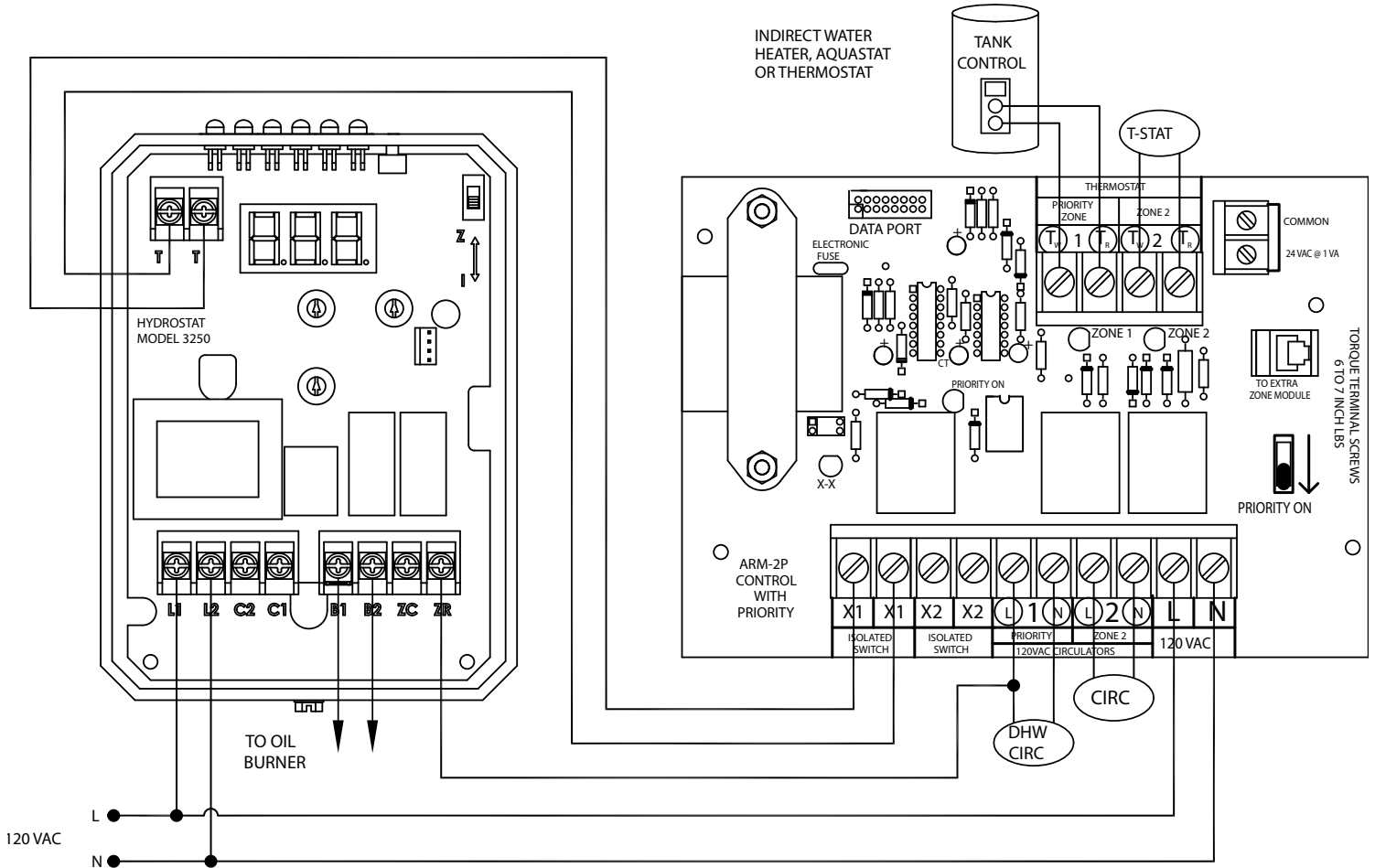
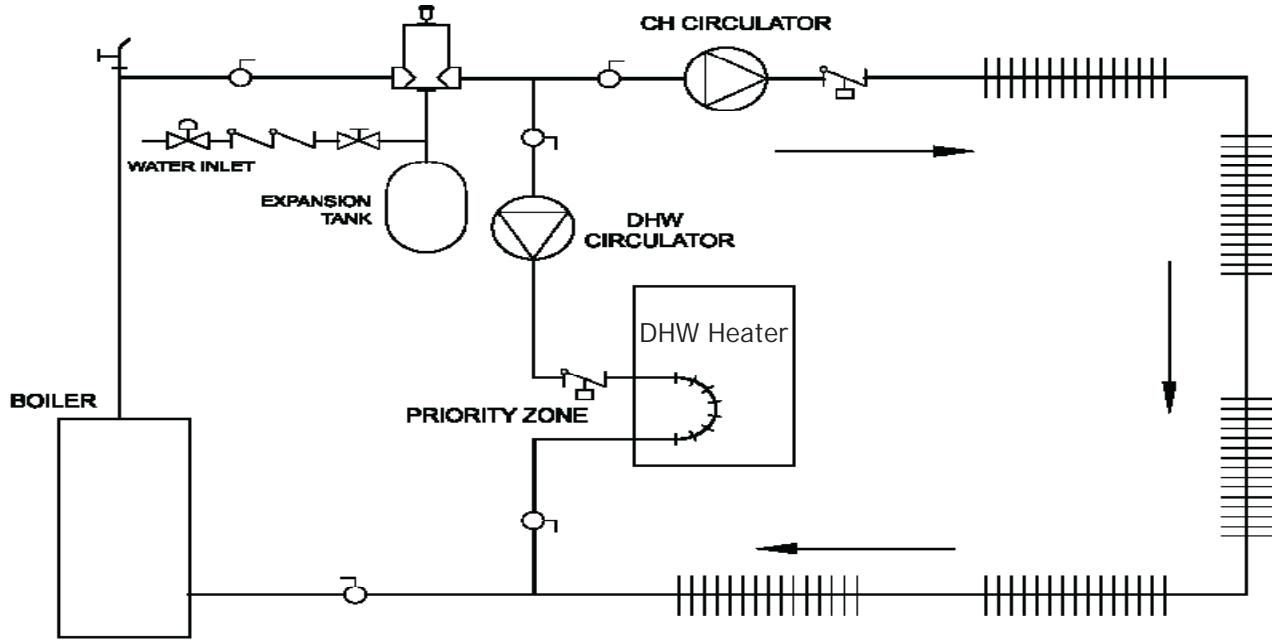

10 - HYDRONIC PIPING

Figure 19 - Multi-Zone Piping and Wiring With Zone Valves And Domestic Hot Water Priority (With Zone Valve)

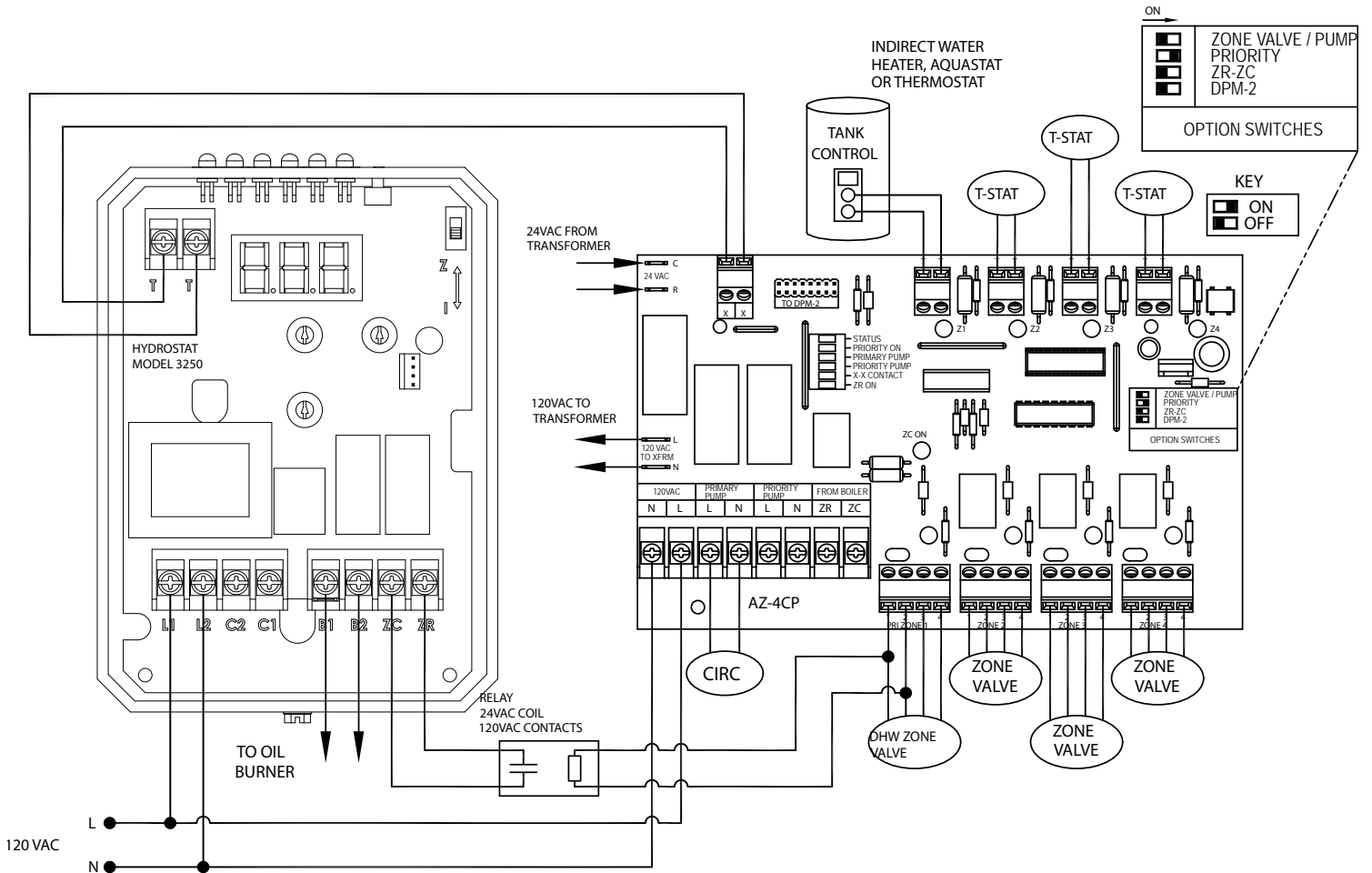
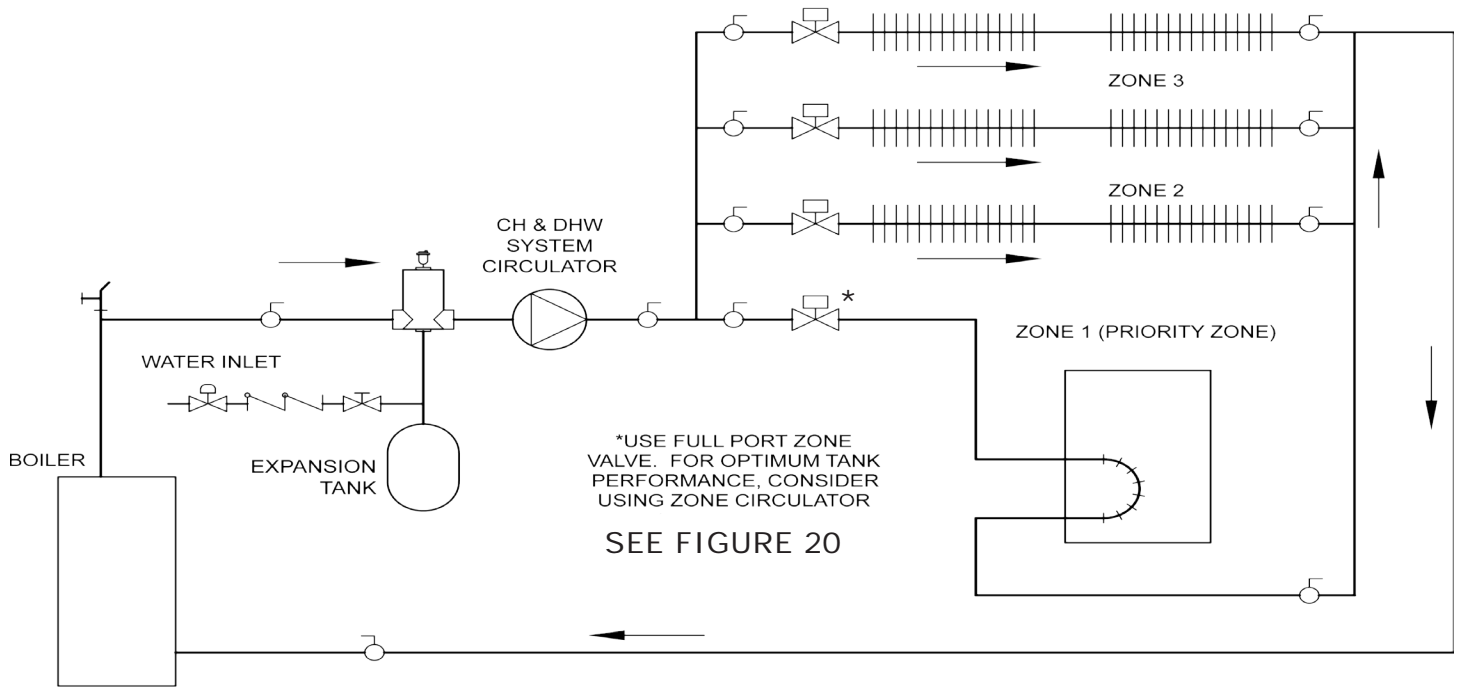

10 - HYDRONIC PIPING

Figure 20 - Piping And Wiring Multizone System With Zone Valves And Domestic Hot Water Priority (With Circulator)

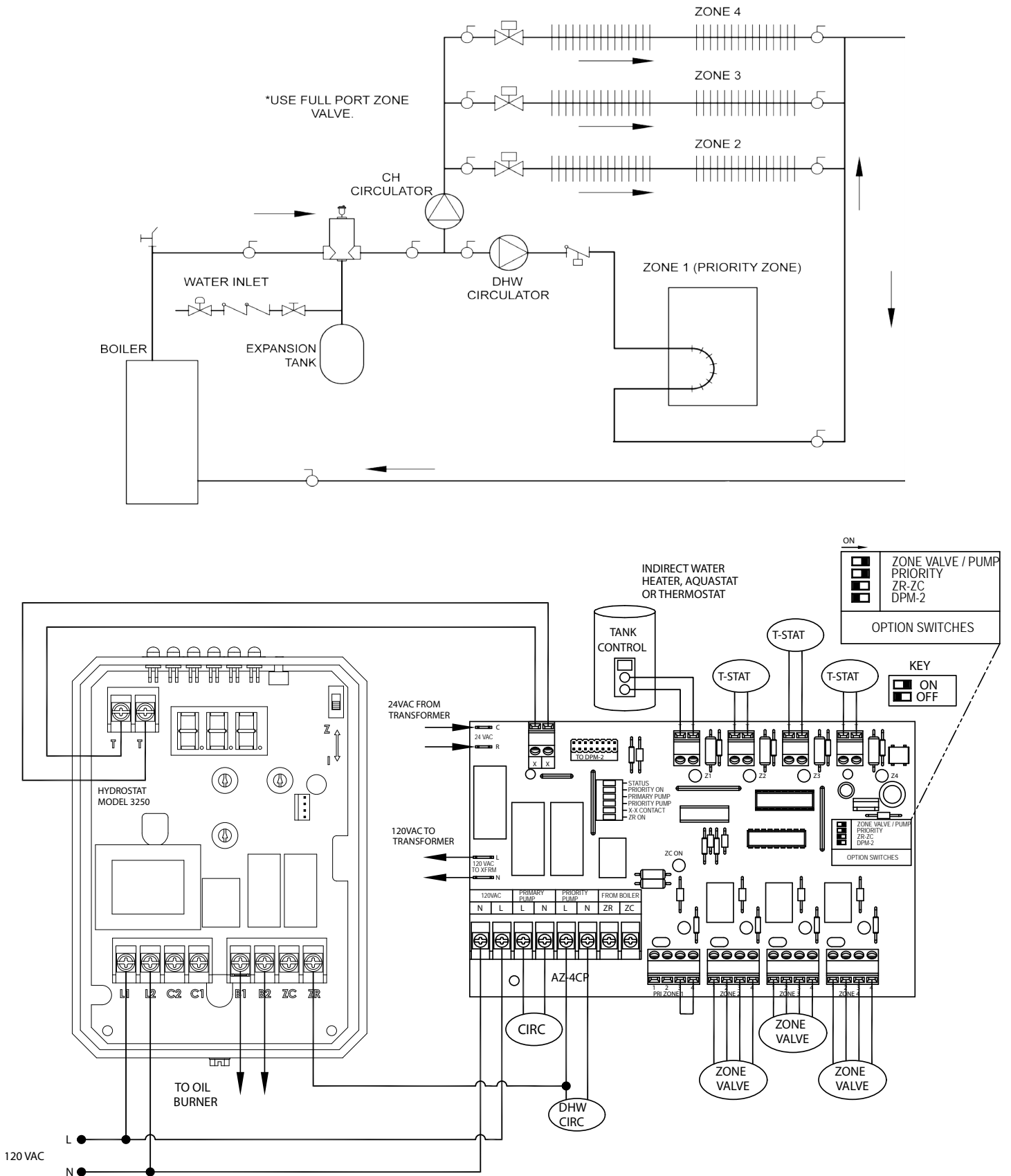

10 - HYDRONIC PIPING

Figure 21 - Piping and Wiring Multi-Zone System With Circulators And Domestic Hot Water Priority

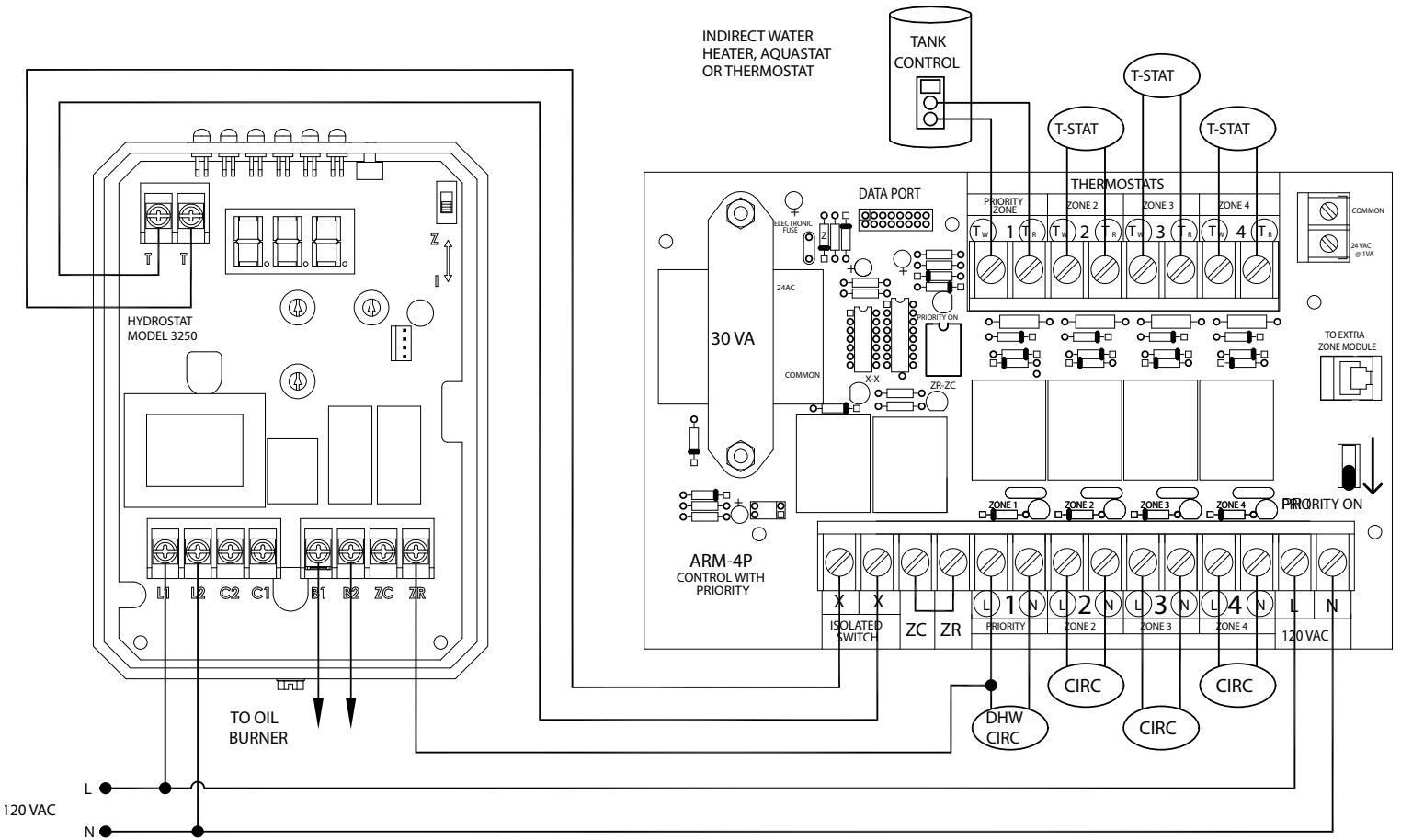
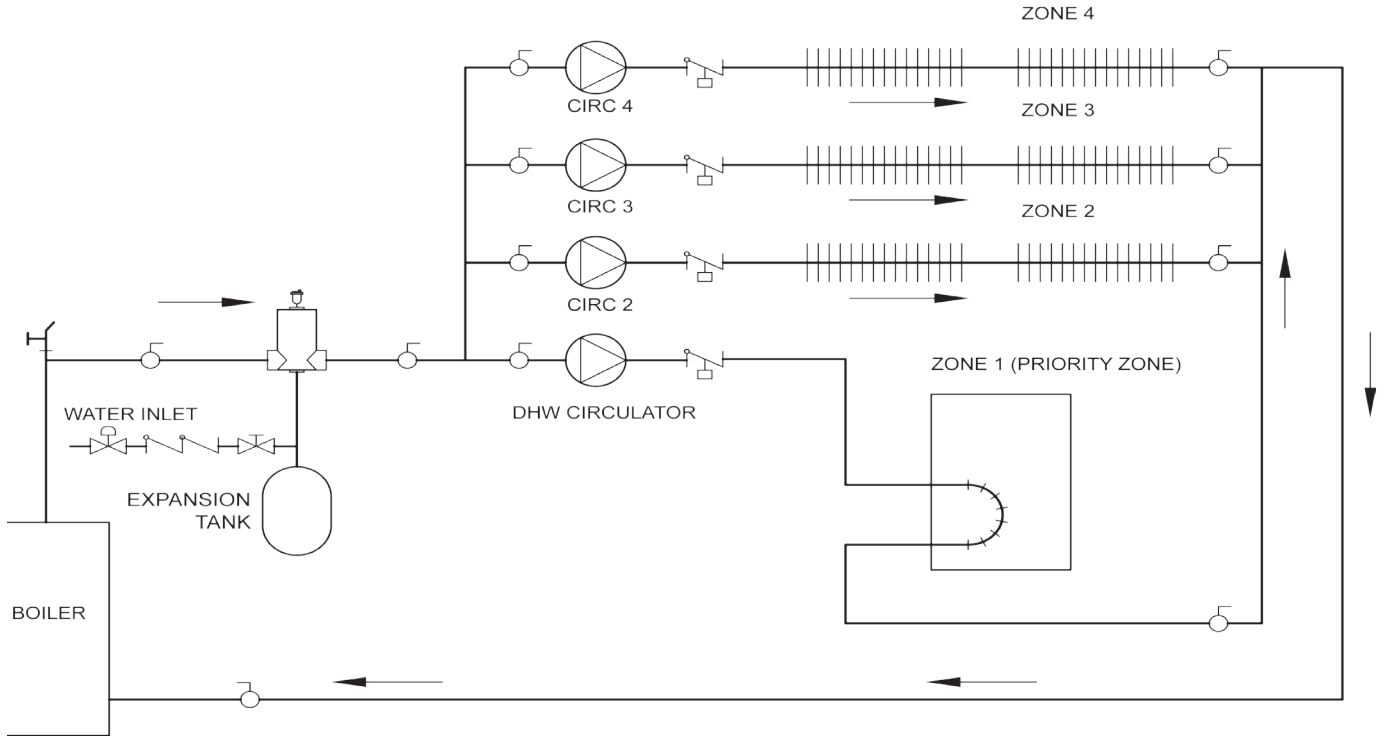

10 - HYDRONIC PIPING

Figure 22 Primary/Secondary Piping And Wiring With Circulators And Domestic Hot Water

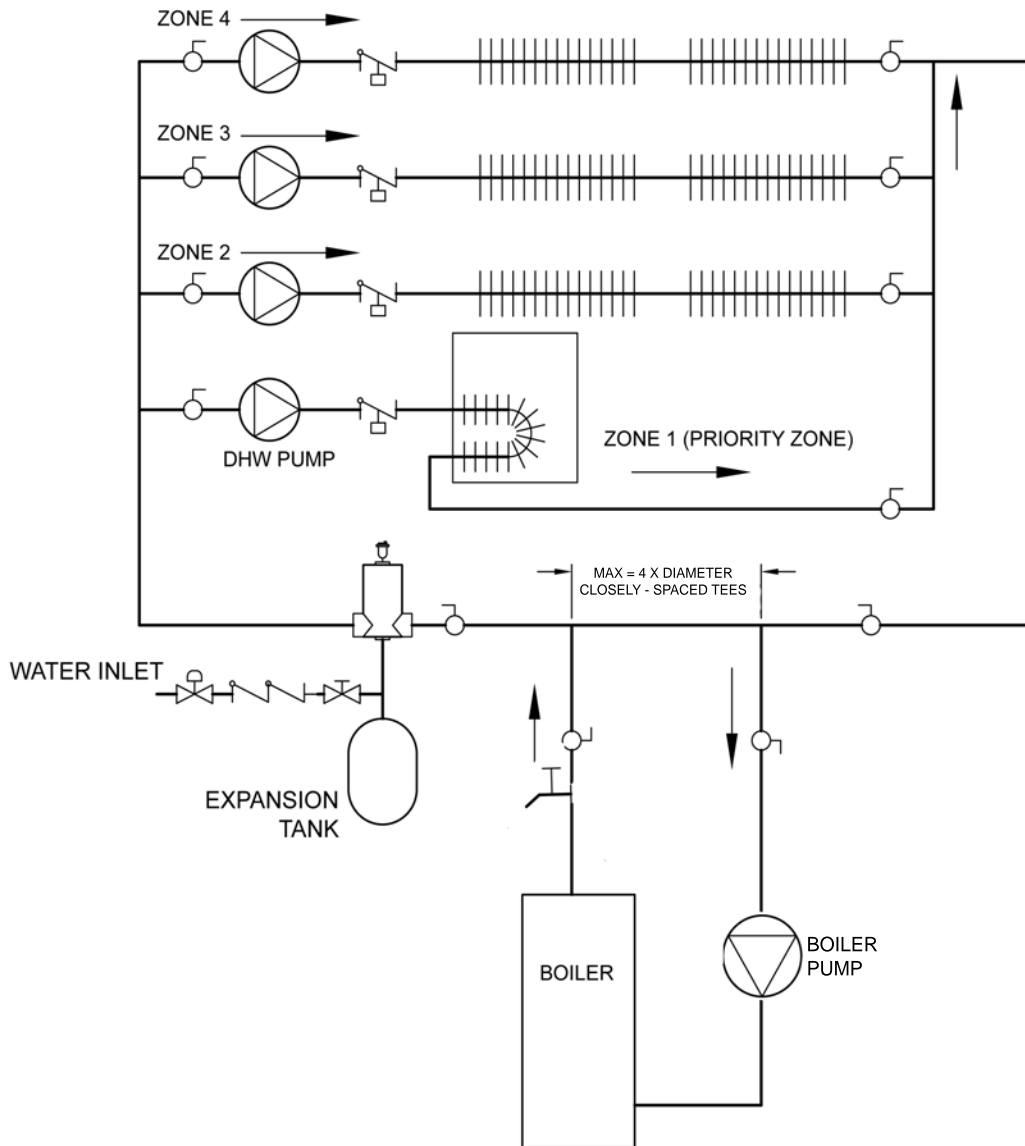

10 - HYDRONIC PIPING

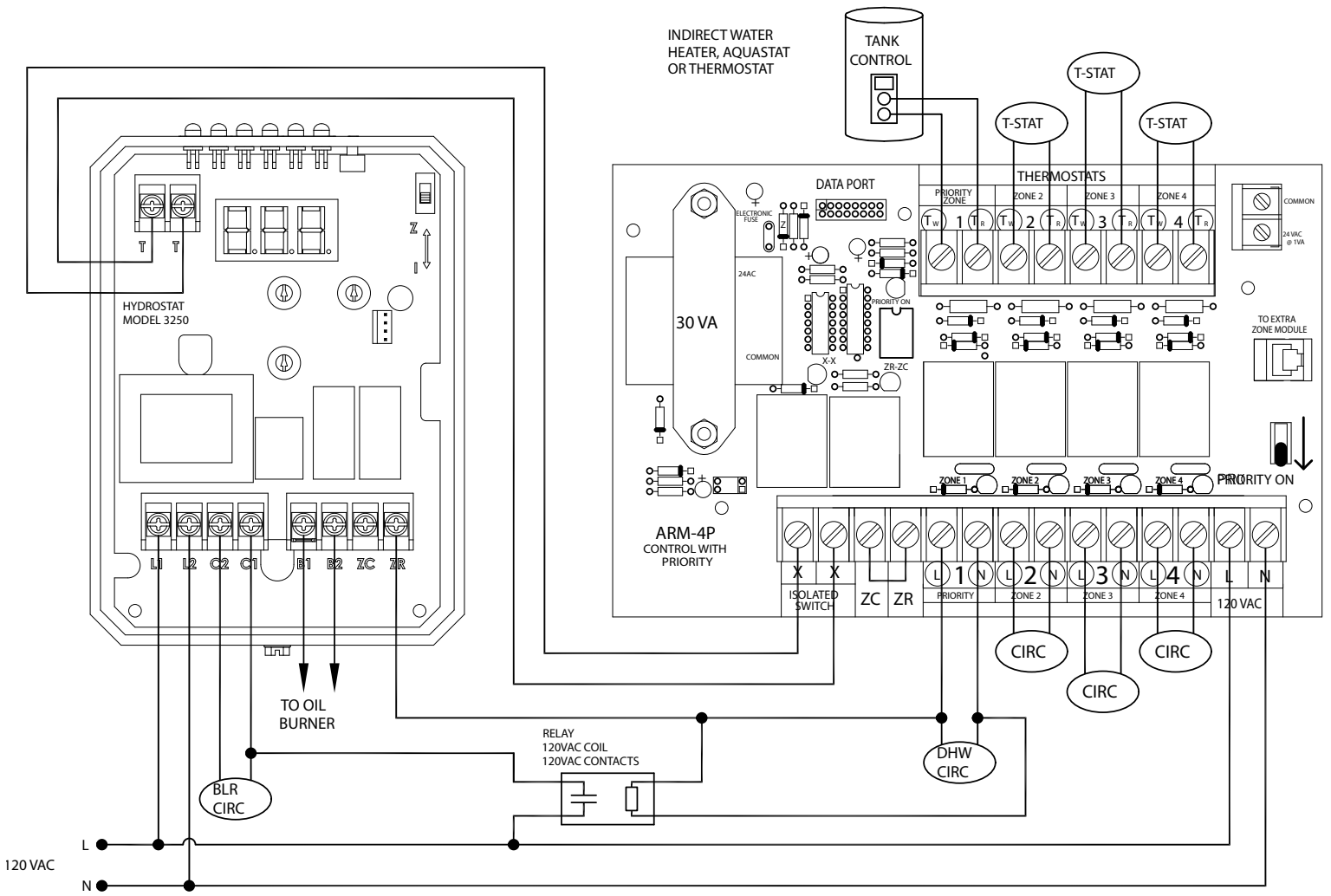

10 - HYDRONIC PIPING

Figure 23 - Piping And Wiring Primary/Secondary Multi Zone System Piping With Zone Valves And Domestic Hot water (With Zone Valve)

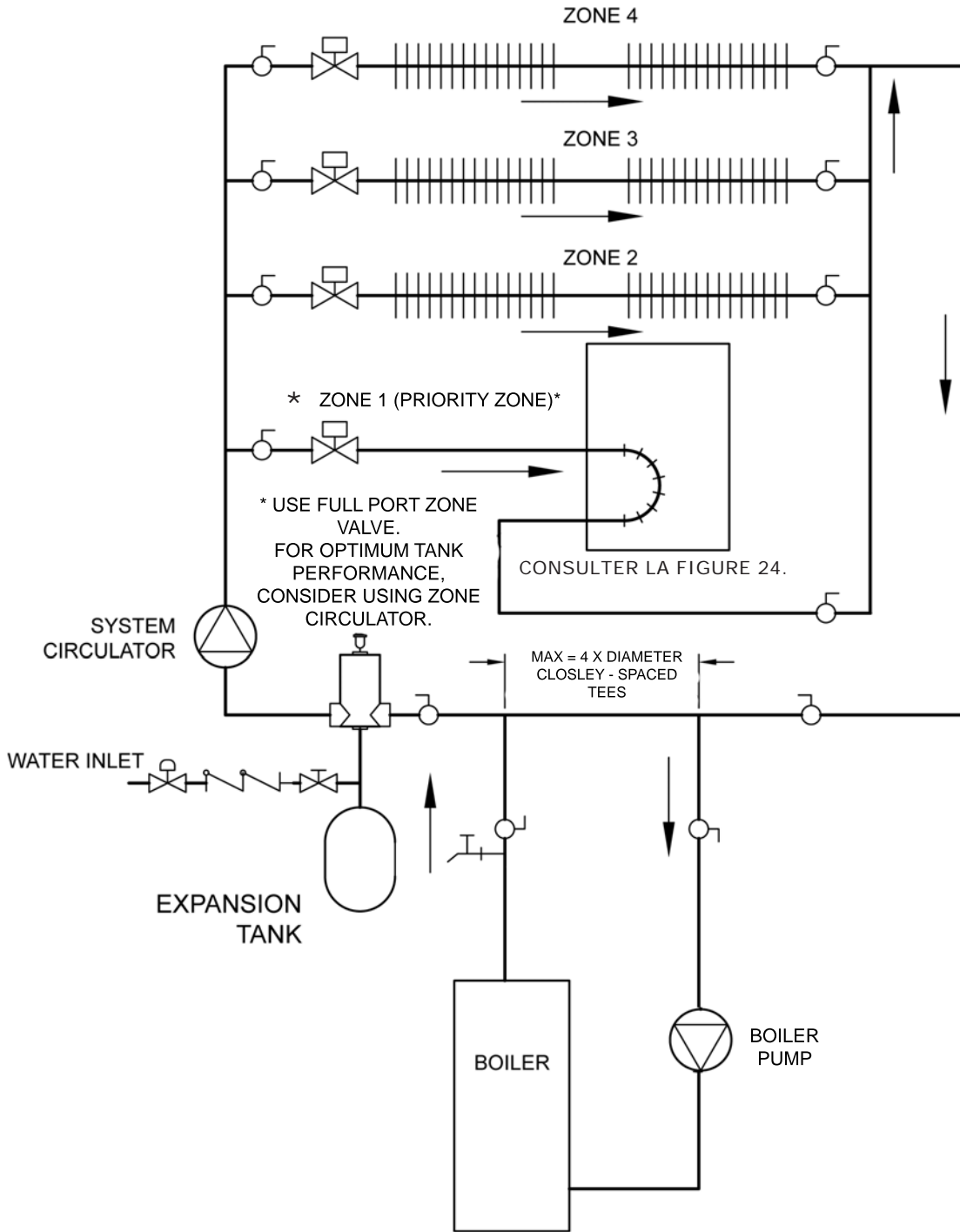

10 - HYDRONIC PIPING

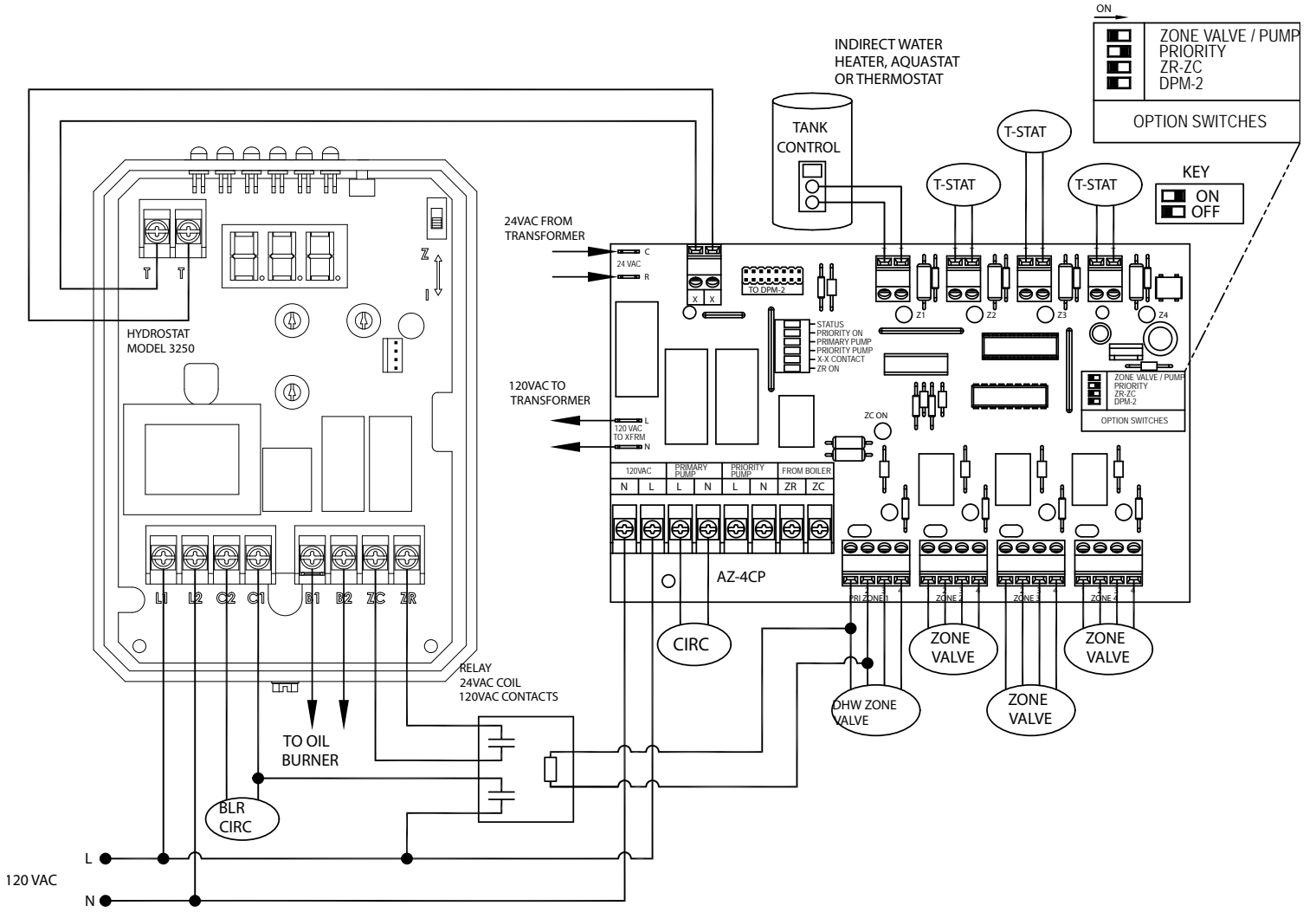

10 - HYDRONIC PIPING

Figure 24 - Piping And Wiring Primary/Secondary Piping With Zone Valves And Domestic Hot Water (With Circulator)

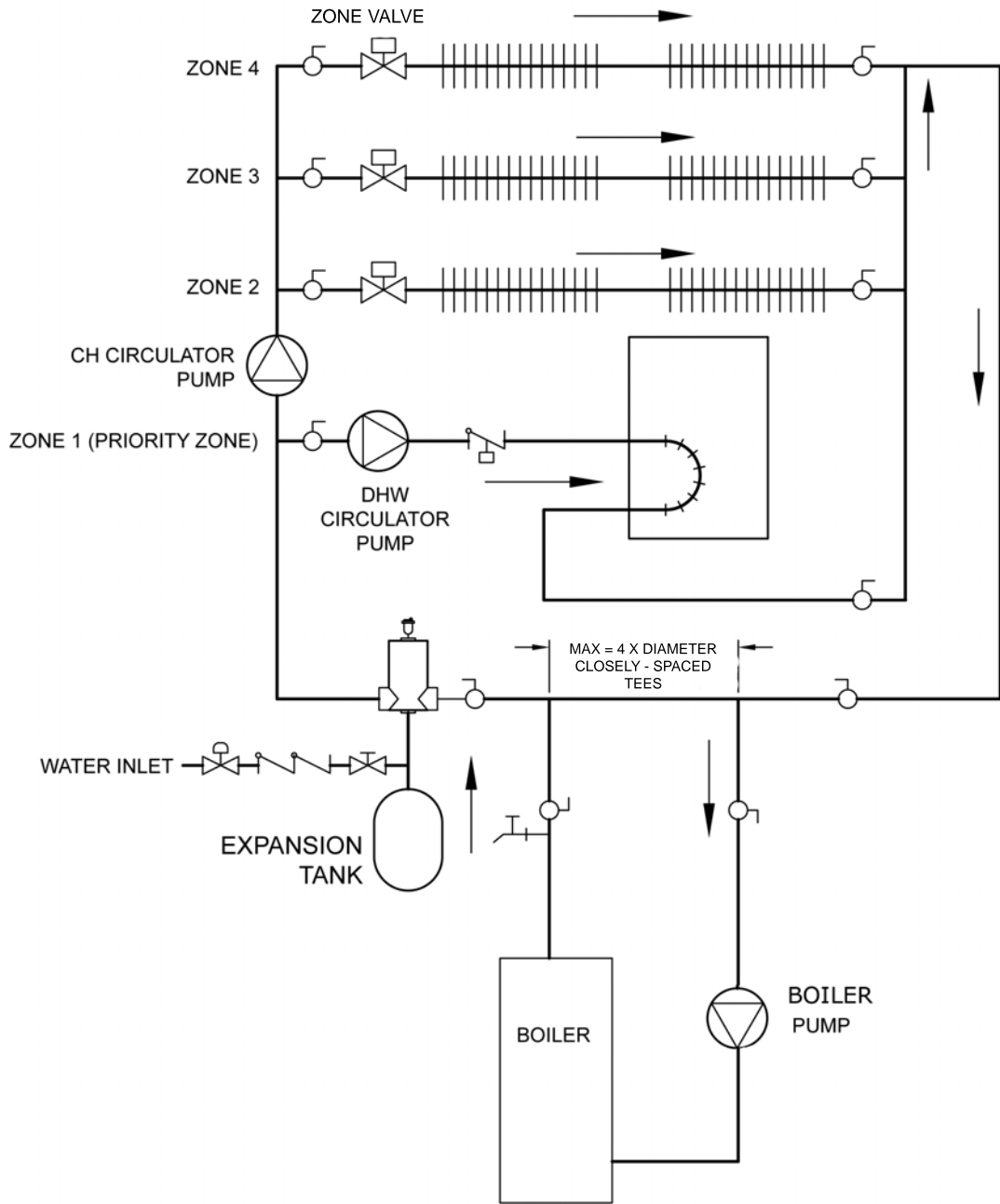

10 - HYDRONIC PIPING

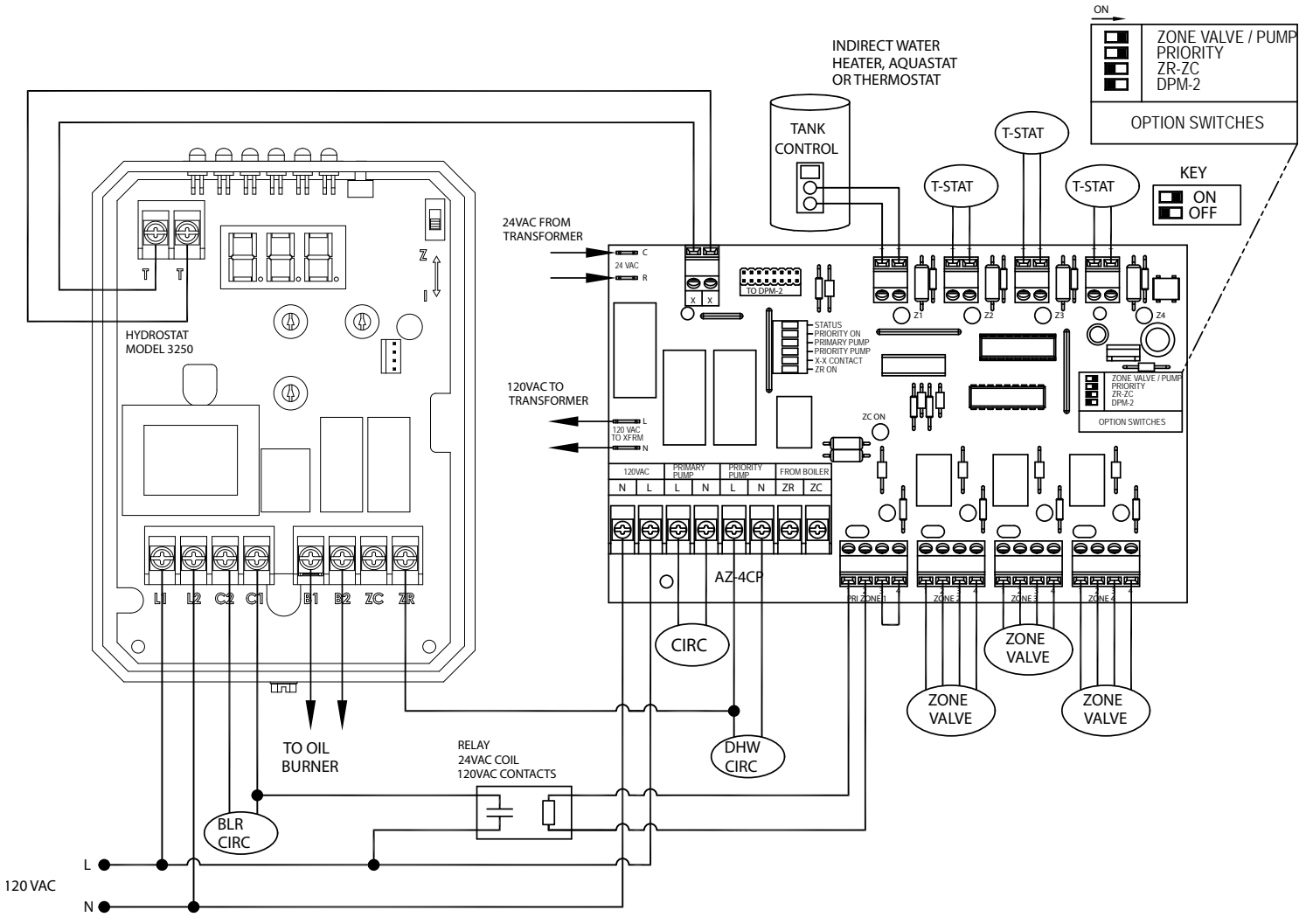

10 - HYDRONIC PIPING

Figure 25 Bypass Piping (Fixed Low Temperature Only)

Adjust two throttling valves to maintain at least 130°F - 140°F in boiler return.

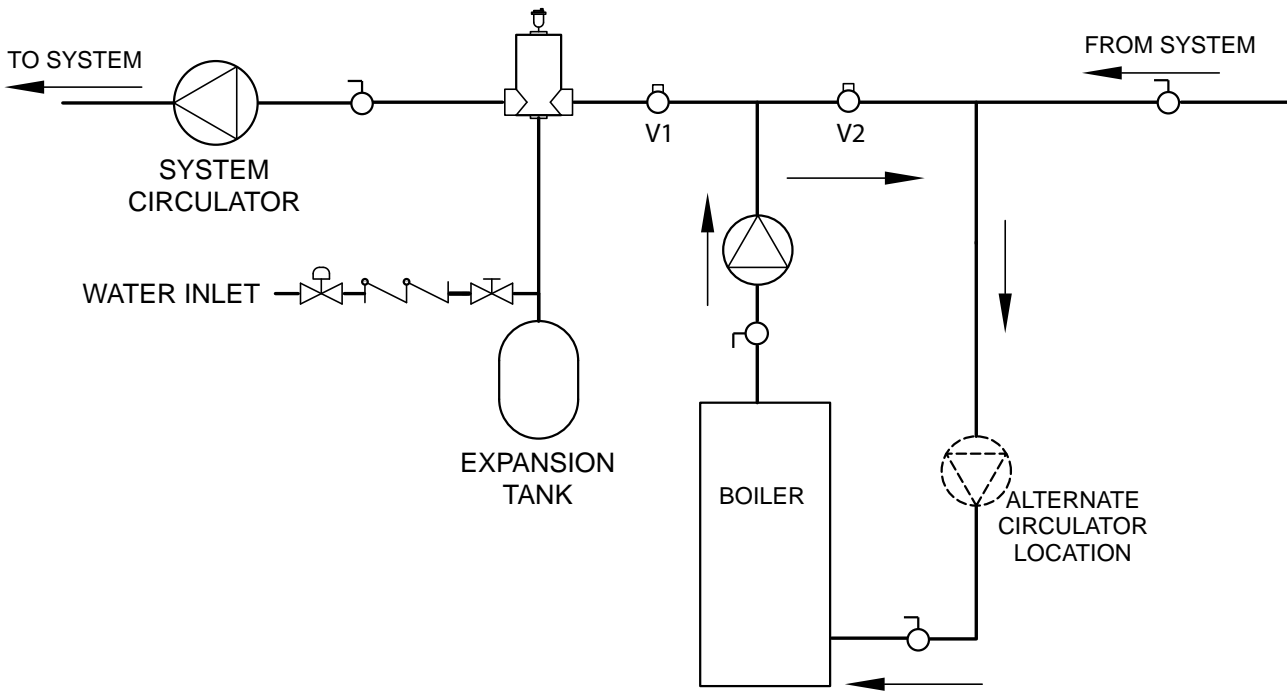

Figure 26 - Bypass Piping Automatic Mixing Valve

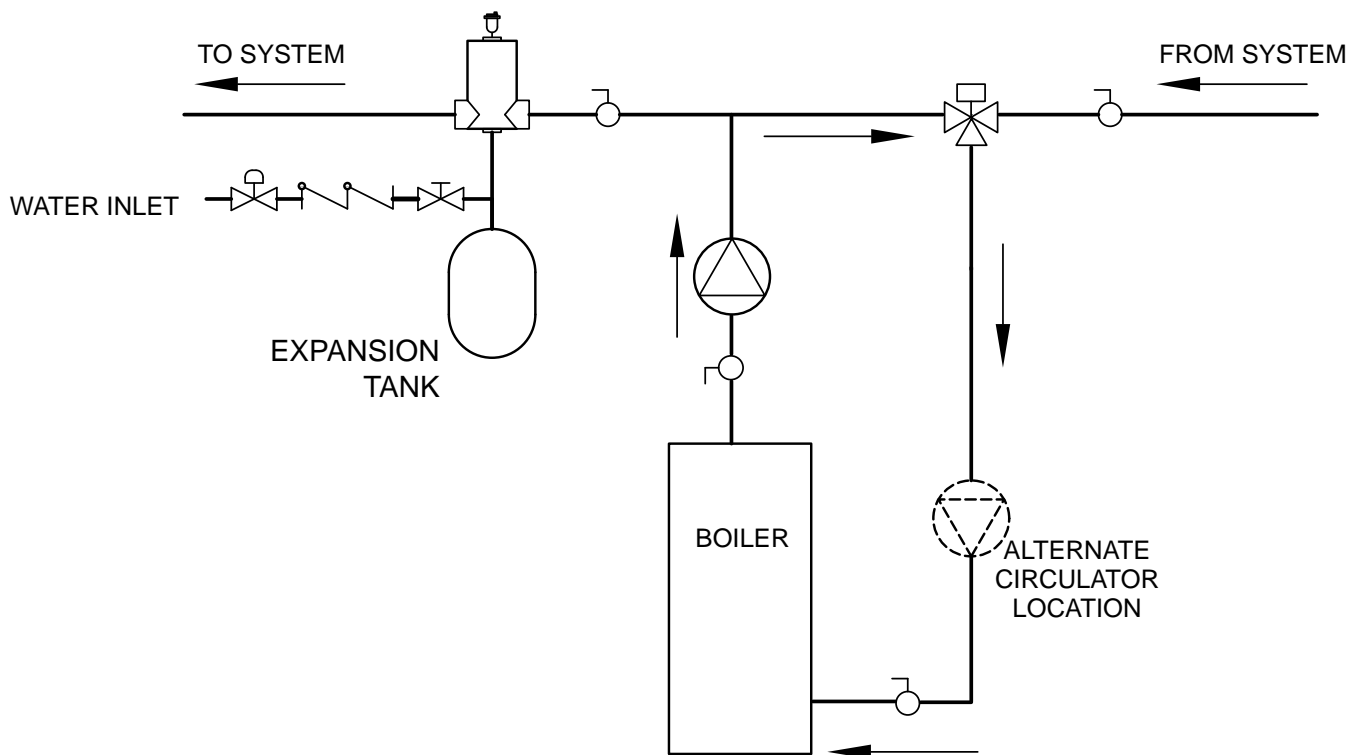

Figure 27 - Bypass Piping (4-Way Valve Option with Circulator On Supply Side)

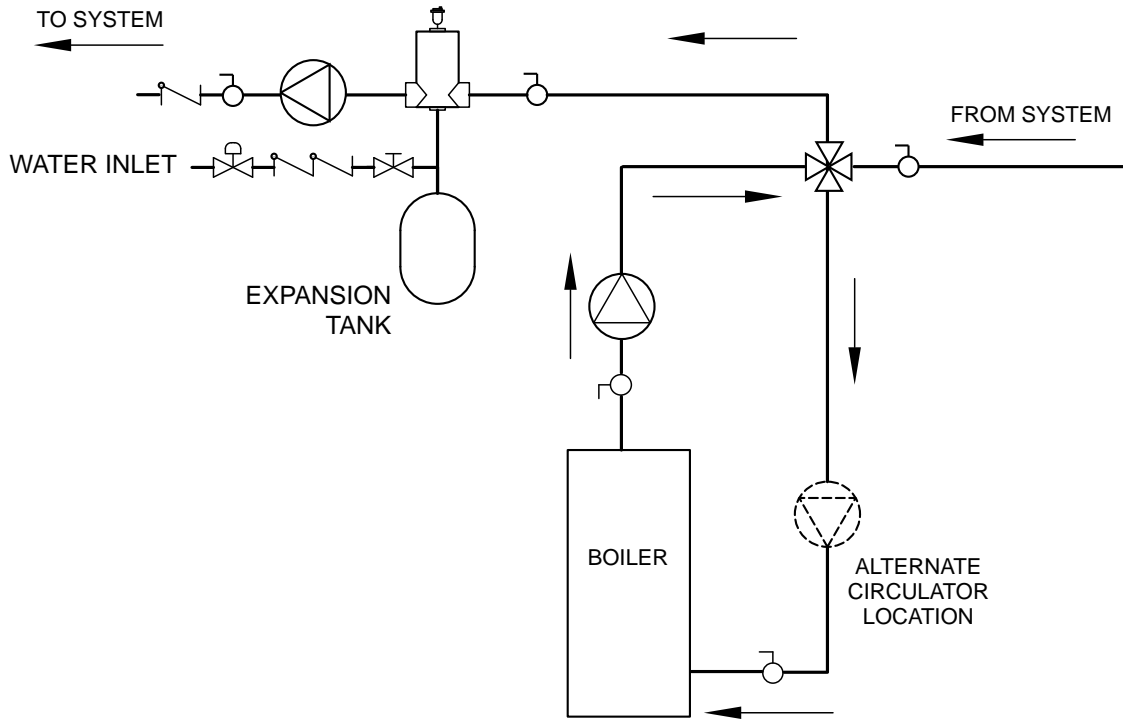
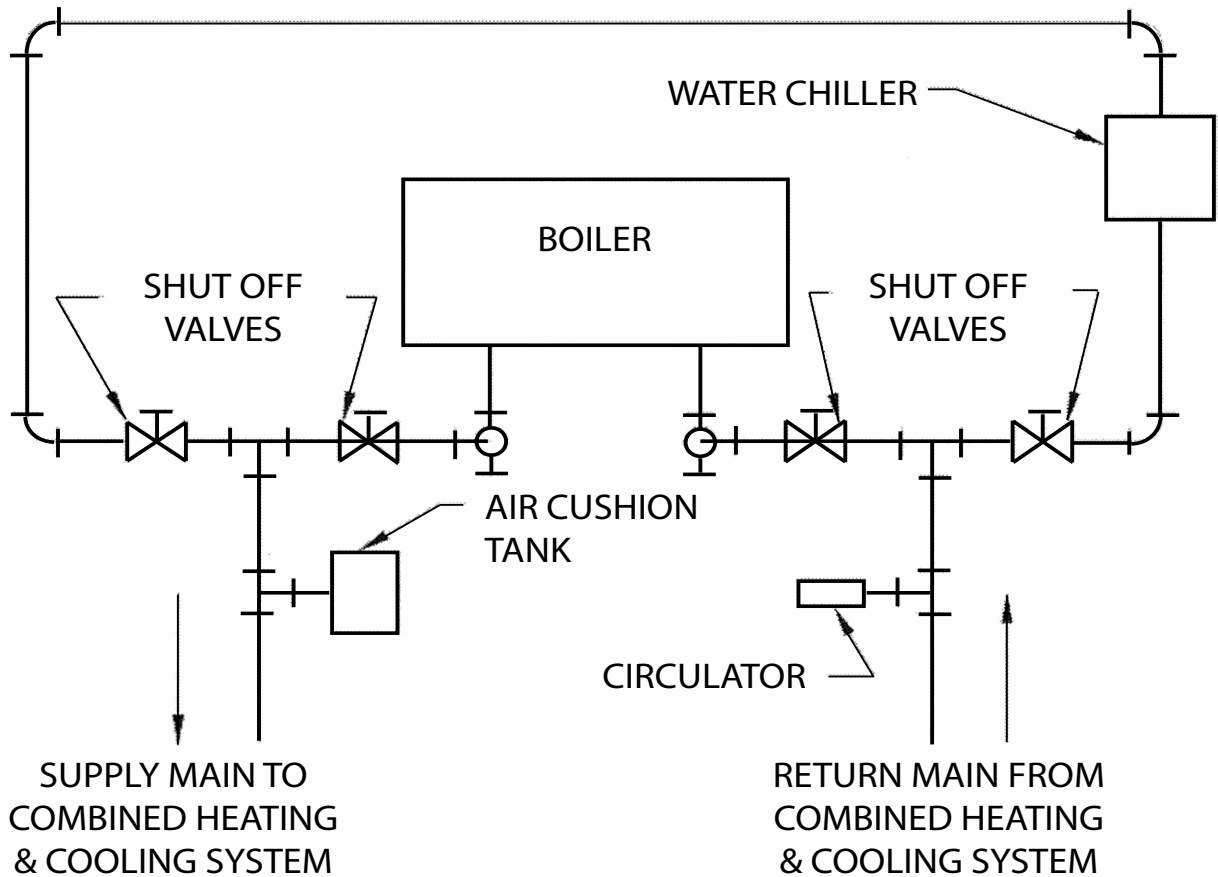

Figure 28 Recommended Piping For Combination Heating and Cooling (Refrigeration) System



11 - FUEL SUPPLY PIPING

11.1 Installation of oil tank and piping shall conform to requirements of authority having jurisdiction or in absence of such requirements National Board of Fire Underwriters. In addition, refer to NFPA 31 (U.S.). Installation of oil storage tank, vent, fill pipe and caps shall conform to requirements of authority having jurisdiction.

- In no case should vent pipe be smaller than 1¼" I.P.S.
- Fill pipe should not be less than 2" I.P.S.
- Suction line from tank to burner should be one continuous piece of tubing to prevent air entering line
- Suction line, must be ¾" O.D. copper tubing for runs of 50 feet or less, and ½" O.D. for longer runs.
- Use oil return line, same size as the suction line, on installations where bottom of tank is below fuel unit of burner.
- Bury oil lines or protect from mechanical injury.
- Flare fittings on all oil lines are required. Compression fittings on suction line often allow air to be drawn into fuel pump, making it difficult to maintain oil pressure at nozzle.
- Do not run overhead fuel lines from tank to oil burner.
- Follow instructions, attached to fuel pump, for fuel pump and by-pass connections.
- Install two stage fuel unit if tank is more than 20' from boiler in place of single stage pump supplied as standard equipment with burner. Verify rotation and speed are identical and pump is suitable for burner horsepower rating.
- Install oil line filter and shut-off valve in suction line.
- Install Shut-off valves in both suction and return lines at burner for convenience in servicing burner.
- Allow extra tubing at burner so burner may be removed from boiler for cleaning without disconnecting tubing. See Figures 29 and 30.
- Use flexible oil lines so burner swing door can be opened without disconnecting oil supply piping.

Figure 30 - Double Pipe Oil Line

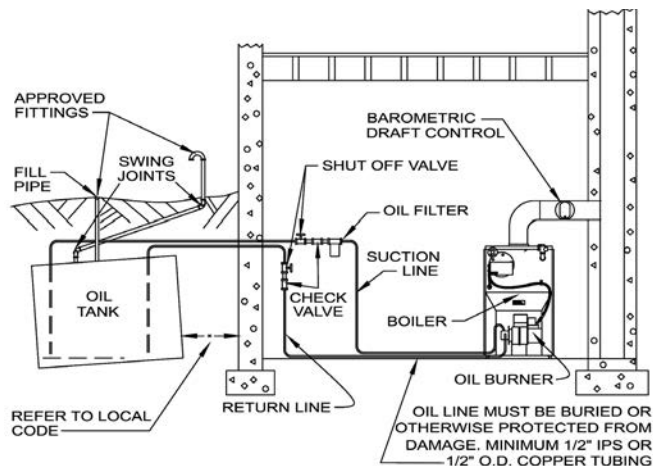

Figure 29 - Single Pipe Oil Line

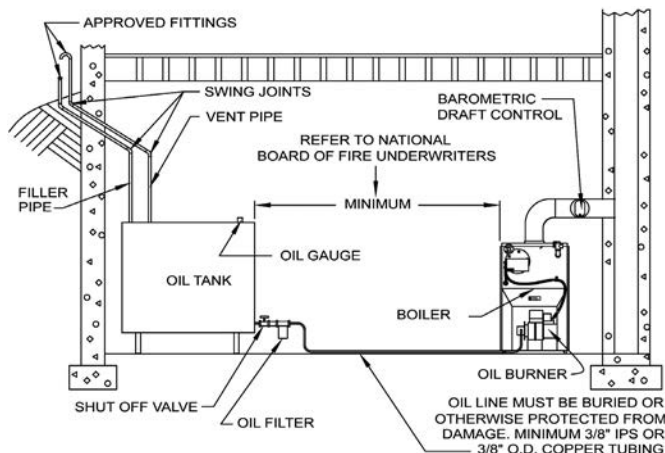

Table 5 - TWO STAGE UNITS, TWO PIPE SYSTEMS (SEE FIGURE 20)		
LIFT "H"	Maximum Length of Tubing "R"	
	3/8" O.D. Tubing (3 GPH)	1/2" O.D. Tubing (3 GPH)
0	93 FT.	100 FT.
2	85 FT.	100 FT.
4	77 FT.	100 FT.
6	69 FT.	100 FT.
8	60 FT.	100 FT.
10	52 FT.	100 FT.
12	44 FT.	100 FT.
14	36 FT.	100 FT.
16	27 FT.	100 FT.
18	---	76 FT.

12 - ANTIFREEZE IN THE SYSTEM

12.1 Antifreeze added to boilers must be nontoxic, and must be of type specifically intended for use in closed hydronic heating systems. Under no circumstances should automotive antifreeze be used. Antifreeze used in any boiler may reduce capacity by 10% or more and increase fuel consumption. See Table 6 and 7.

Table 6 - BOILER WATER VOLUMES

Number of Boiler Section	Total Volume (Gallons)
4	3.6
5	4.3
6	5.1
7	5.9

Table 7 - PIPING WATER VOLUMES

PIPE SIZE	COPPER PIPE FACTOR	STEEL PIPE FACTOR
½"	82.5	63.5
¾"	40.0	36.0
1"	23.3	22.2
1 ¼"	15.3	12.8
1 ½"	10.8	9.5
2"	6.2	5.8

Divide total length of piping in feet by appropriate factor in table to determine volume in gallons.

13 - ELECTRICAL CONNECTIONS

WARNING

Electrical shock hazard. Turn OFF electrical power supply at service panel before making electrical connections. Failure to do so could result in death or serious injury.

13.1 Electrical wiring shall conform to requirements of authority having jurisdiction or in absence of such requirements ANSI/NFPA No. 70.

Run separate electrical circuit from entry box with fused disconnect switch in this circuit.

Never "jump out" or make inoperative any safety or operating controls.

**SEE APPROPRIATE ADDENDUM FOR WIRING
DIAGRAMS**

14 - CHIMNEY AND VENTING CONNECTIONS

14.1 Chimney Venting

Oil fired boilers with connections to vents or chimneys, vent installation shall conform to requirements of authority having jurisdiction or in absence of such requirements NFPA 31 Installation Of Oil Burning Equipment (U.S.) or CSA B139 (Canada) and applicable provisions of local building codes.

Installation shall conform to requirements of NFPA31 – Standard for the Installation of Oil-Burning Equipment and NFPA 211 – Standard for Chimneys, Fireplaces, Vents, and Solid Fuel-Burning Appliances (Installations in U.S.) or CSA B139 – Installation Code for Oil-burning Equipment. (Installations in Canada).

1. Ensure sufficient draft during heating season to allow for safe evacuation of flue gasses.
2. Boiler can be vented into fireclay tile-lined masonry chimney or type L vent or factory built chimney that complies with type HT requirements of UL103. See Figure 32.
3. Chimney Inspection – Prior to installation of any new or replacement fuel burning equipment chimney shall be inspected by qualified service agency.
 - A. De-rating may cause condensation on interior walls of chimney and boiler. Loose mortar can be indication of history of condensing flue gases upon inside walls of chimney. Do not install chimney until it meets requirements of NFPA 211 or CSA B139.
 - B. Unlined Chimney – Do not install boiler if chimney is constructed of brick only. Only approved clay liners or listed chimney lining systems shall be used as specified in NFPA 31 or CSA B139.
 - C. Abandoned Openings – Seal Openings through chimney wall that are no longer used in accordance to NFPA 211.
 - D. Clean Chimney – Chimney shall be free of all loose debris.
4. Install draft regulator at least 18" above breech; 18" of straight run up-stream of regulator ensures proper operation.
5. Draft Regulator – Use supplied draft regulator with this appliance. Do not use any other draft regulator. See Figure 31.

Table 8 - Recommended Minimum Chimney Sizes

FIRING RATE (gph)	CHIMNEY HEIGHT (ft)	NOMINAL CHIMNEY	ROUND LINER INSIDE	SQUARE LINER INSIDE
0.60 -1.30	15	8" x 8"	6"	6 ¾" x 6 ¾"
1.31 -1.80	15	8" x 8"	7"	6 ¾" x 6 ¾"

For elevations above 2,000 feet above sea level, add 3 feet to the chimney heights.

14.2 Chimney and Chimney Connector

1. Chimney connector should be kept as short as possible. Horizontal length of chimney connector should not be greater than 10 feet.
2. Type L Vent pipe or other suitable material may be used for chimney connector if flue temperature is less than 570° F.
3. 4,5 & 6 section boilers are equipped with a sheet metal flue collar for attaching 5" diameter chimney connector. Attach chimney connector to flue collar with 3 standard sheet metal screws (field supplied).
4. 7 section boilers are equipped with a cast iron flue collar for attaching 6" diameter chimney connector. Attach chimney connector to flue collar using furnished drill bit to drill holes for furnished screws. Vent Connection Kit (drill bit and screws) furnished in accessory carton. Pre-drill to avoid cracking cast iron flue collar.
5. Canadian installations require blocked vent safety switch, included with boiler. Refer to separate instruction sheet for installation. Install on boiler flue collar prior to installing chimney connector.
6. Inspect chimney and connector annually for signs of debris and corrosion. Loose mortar at base of chimney may be sign of condensate damage to chimney.
7. Inspect base of chimney for any signs of seepage. Discoloration may be a sign of chimney damage. Have repaired immediately.
8. Contact qualified service agent immediately to examine damage and correct. Operation of damaged chimney may cause venting failure and force flue gases into living space.
9. If chimney is to be re-lined, use recommendations in NFPA31, Appendix E or CSA B139.

14.3 Draft

- Natural draft generated through chimney is dependent on several factors including, chimney height, temperature of flue gases, cross section area of chimney, chimney wall insulation value, dilution air and total volume of flue gases. Operate boiler for at least 5 minutes before measuring draft.

- Minimum Draft at Breech – Draft induced by the chimney must create at least a neutral pressure of 0 (zero) inches water column (INWC) at breech. Slightly negative (i.e. suction) pressure is preferred. Pressure at breech cannot be positive since this could create condition that allows flue gas by-products to escape from draft regulator. Draft is to be measured up stream of draft regulator. See Burner Specifications.
- Over-fire Draft - Measure pressure at 1/4" NPT test port. Three pass boilers have higher pressure drop than single pass. Table 9 shows expected pressure drop between over-fire and breech. Total pressure drop is difference between over-fire draft and breech draft. For example, if over-fire draft = 0.05 INWC and breech draft = - 0.05, total pressure drop = 0.05 - (-0.05) = 0.10 INWC. See Figure 33.

Table 9 - Pressure Drop Between Over-Fire & Breech	
Sections	Inches WC
4	0.04-0.06
5	0.05-0.08
6	0.09-0.16
7	0.07-0.16

14.4 Stack Temperature

1. Higher stack temperature, greater amount of draft generated. Lower stack temperature not only reduces amount of draft created but also increases possibility flue gases could condense in chimney connector or stack.
2. Consult NFPA 31 and CSA B139 for information for appropriate choice of venting materials. Chimney may have to be lined to create sufficient draft, or chimney may have to be lined to prevent corrosion of masonry chimney. Consult qualified service agency for chimney requirements in your area.
3. Baffles – Efficiency of boiler is based on insertion of flue baffles supplied with 4,5 & 6 section units. Baffles are installed in 3rd pass (two inner flueways). Refer to "8 - Boiler Assembly" for baffle installation. Remove baffles to increase stack temperature.
4. Remove baffles if any signs of condensation in chimney or chimney connector. Removing baffles may not address condensation.

Figure 31 - Proper Draft Regulator Locations

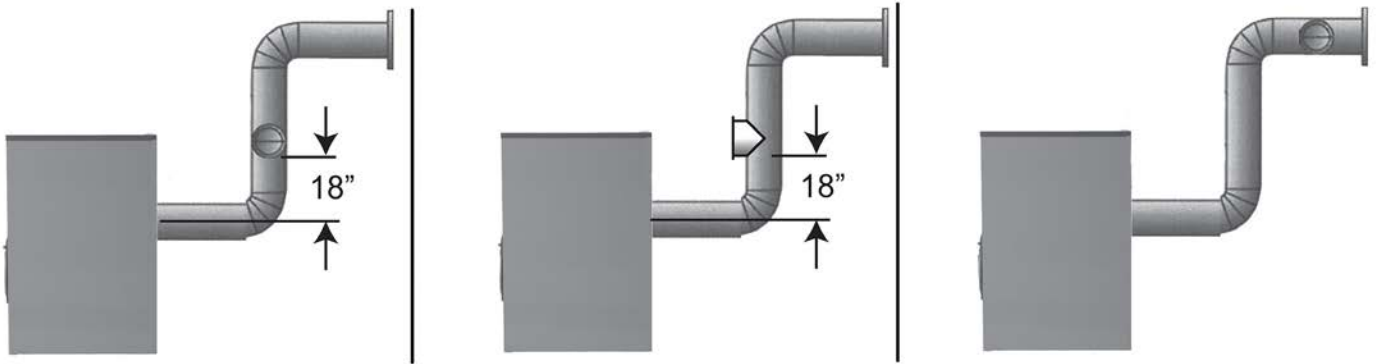

Figure 32 - Typical Chimney Locations

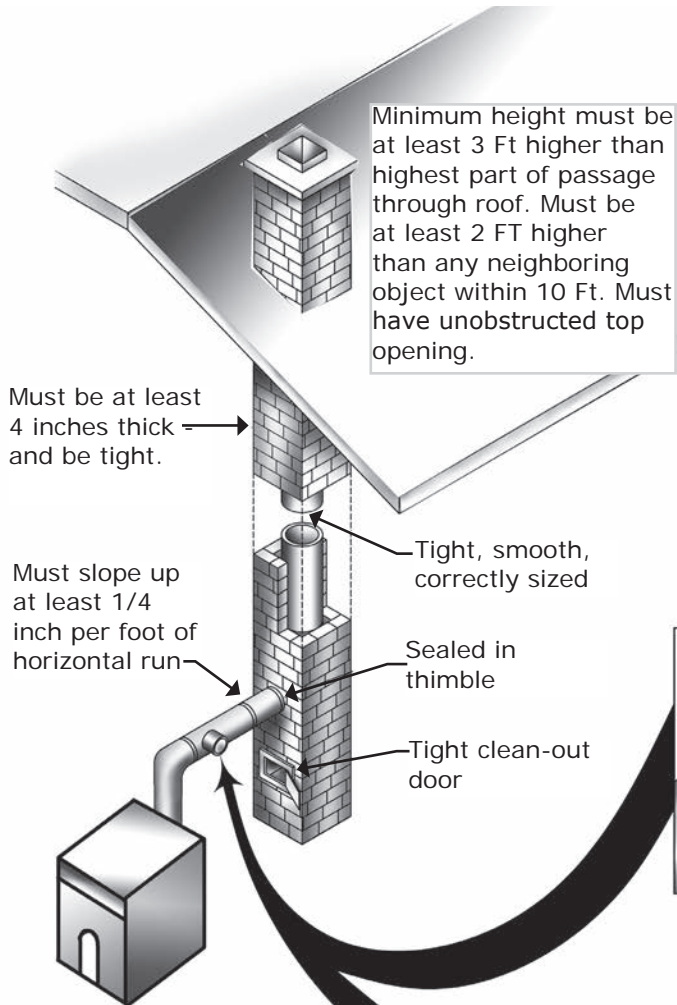
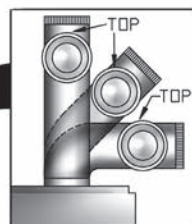
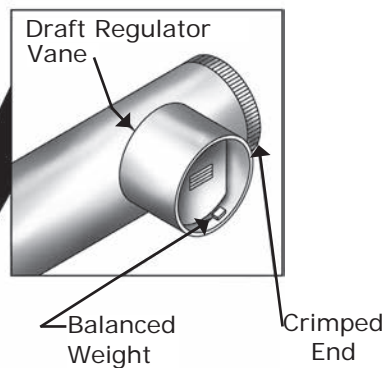
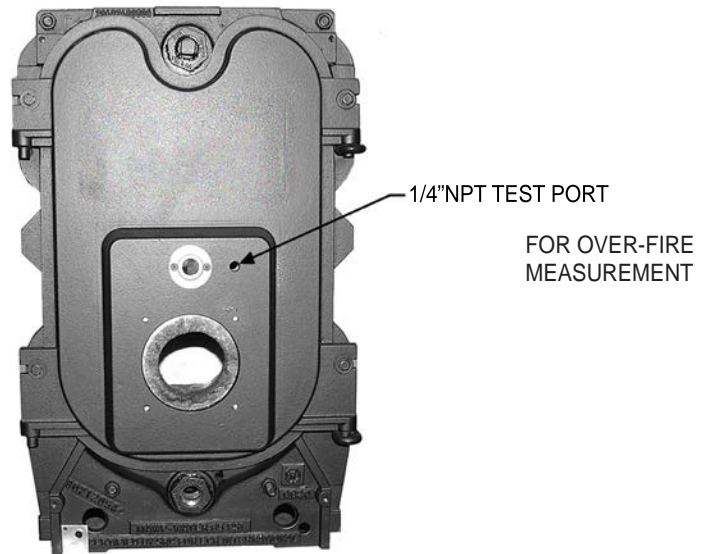

Figure 33 - Pressure Tapping for Checking Draft



WARNING

Fire, burn, asphyxiation hazard. Turn off service switch to boiler to prevent accidental firing of burner outside combustion chamber. Disconnect burner power cord from wire harness in front jacket. Tighten swing door fastener completely when service is complete. Failure to follow instructions in this manual and understand all requirements could result in death or serious injury.

1. Inspect Installation Before Starting Burner.
 - A. Verify venting, water piping, oil piping, and electrical system are installed properly. Refer to installation Instructions contained in this manual.
 - B. Confirm all electrical, water and oil supplies are turned off at source and vent is clear from obstructions.
2. Fill Heating System With Water.
 - A. Failure to clean system can result in clogged air vents, circulator damage and seized zone valves.

Clean heating system if boiler water is dirty. Refer to "18 - Maintenance" for proper cleaning instructions for water boilers.

Fill entire heating system with water and vent air from system.

Use following procedure on series loop or multi-zoned system installed as per piping diagrams, to remove air from system when filling:

- A. Close shut off valve in boiler system piping between air separator and vertical purge valve.
- B. Isolate all zones by closing zone valves or shut-off valves in supply and return of each zone(s).
- C. Attach hose to vertical purge valve in boiler system supply piping. Terminate hose in five gallon bucket or suitable floor drain or outdoor area.
- D. Starting with one zone at a time, open zone valve or shut-off valve in boiler supply and return piping.
- E. Open purge valve.
- F. Open shut-off valve in cold water supply piping.
- G. When zone is completely purged of air, close zone valve or shut-off valve. Open valve to next zone to be purged. Repeat this step until all zones have been purged. At completion, open all valves.
- H. Close purge valve, continue filling system until pressure gauge reads 12 psi. Close shut-off valve in cold water supply piping.
- I. Open shut off valve in boiler system piping.
- J. Remove hose from purge valve.
- K. Confirm boiler and system have no water leaks.

NOTICE

Boiler maximum operating pressure is posted on ASME data label located on front lower leg of boiler. Never exceed this pressure. Do not plug relief valve.

- L. It may be necessary to clean air vent assembly after few days of operation.
3. Check controls, wiring and burner. Verify all connections are tight and burner is rigid, all electrical connections have been completed and fuses installed, and oil tank is filled and oil lines have been tested.

16.1 Setting The Limit Control

Setting can be verified using TEST/SETTINGS button. See Page 42.

16.2 Setting High Limit

To adjust, turn HI TEMP dial **A** until desired setting is displayed. See Figure 24. Overall range of High limit setting is from 100°F to 220°F (82° C to 104° C). High limit (HL) on limit control is factory set at 190°F. Temperature setting may be varied to suit requirements of installation. Differentials are automatic and will vary based on control settings and boiler temperature.

16.3 Setting Low Limit

- Low limit is designed to maintain temperature in boilers equipped with tankless coils used for domestic hot water. Low limit is factory set to OFF.
- For cold start operation, low limit must be turned to OFF.

16.4 Setting Economy Feature (See Figure 35)

- Economy feature is factory set for 1 zone heating system. To adjust, turn ECONOMY dial **D** until number displayed equals number of heating zones.
- Do not include indirect water heaters in number of heating zones.
- Economy feature conserves fuel by reducing boiler temperature. If heating system is unable to supply needed heat to house, ECONOMY dial should be turned to lower setting. (example: in a three zone house, turn dial to 2 or 1).
- Conversely, if boiler provides adequate heat, added fuel savings can be achieved by selecting higher setting (example: 4 or 5).
- If heating and indirect water heater signals were not separated when wiring the control, Economy feature should be turned off to ensure the boiler supplies adequate temperature to heat indirect tank.

16.5 Setting Zone/Indirect Switch

When installing with indirect water heater, zone/indirect switch must be set in the I position, calls to ZC-ZR will bypass thermal targeting feature and allow boiler to fire to high limit setting to heat indirect tank.

Indirect signal must be separate from all heating zone signals.

If you choose not to separate indirect signal from heating zones, turn off economy feature to ensure boiler supplies adequate temperature to indirect tank.

Figure 34 - Limit

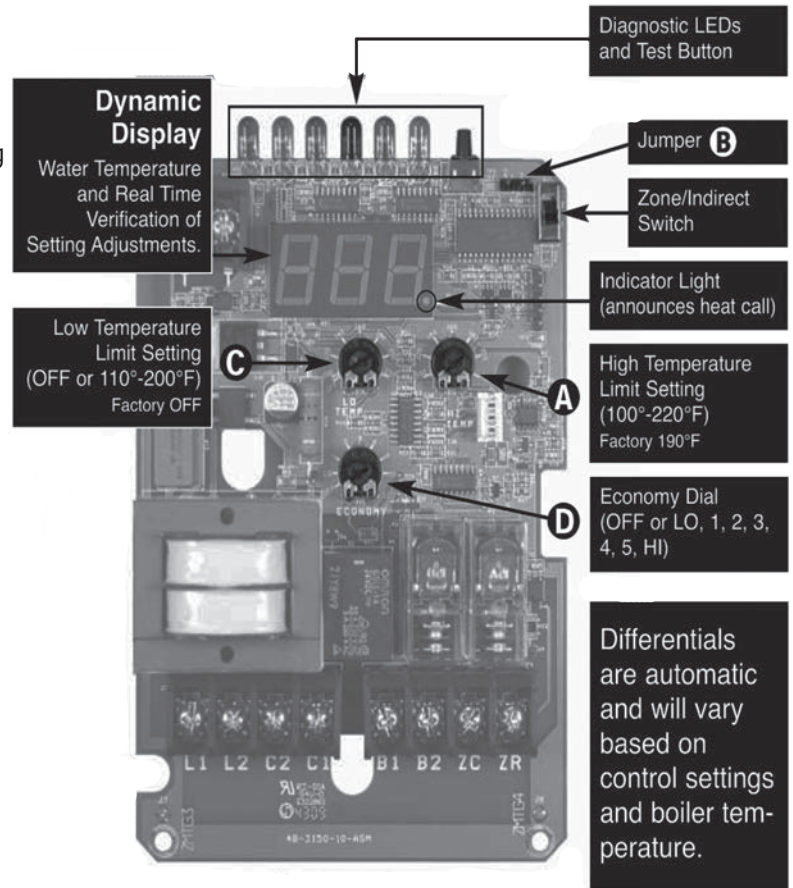

Figure 35 - Setting Economy Feature

SETTING	
OFF	Disables economy function. Will allow boiler to fire until hi-limit temp is reached and re-fire with a 10° subtractive differential.
LO	Provides lowest level of fuel savings. Use this setting only if the house does not stay warm at higher settings.
1	Recommended setting for single zone systems.
2	Recommended setting for Two zone systems.
3	Recommended setting for Three zone systems.
4	Recommended setting for Four zone systems.
5	Recommended setting for Five zone systems.
HI	Provides highest level of fuel savings.

16.6 Activating Thermal Pre-Purge (optional)

Activation of this feature is not recommended for boilers with tankless coils.

- Limit has thermal pre-purge feature to maximize efficiency. When activated, control will purge higher boiler temperatures down to 135°F at start of any thermostat call and supply latent energy in boiler to heating zone calling.
- During purge cycle, display will indicate **PUR**.
- If heat is not sufficient to satisfy thermostat, control will energize burner.
- Feature works with single and multi-zone heating systems utilizing circulators or zone valves. No change in wiring is needed.

To Activate Thermal Pre-Purge

1. Push and hold TEST/SETTINGS button for 20 seconds.
2. Display will read PURR On.
3. To deactivate feature, push and hold button a second time for 20 seconds.
4. Display will read PURR OFF.

16.7 Control Action On System Start-Up

At initial start-up, with economy feature active, control establishes 145°F target temperature. To test high limit shut-off function, economy dial must be turned to off.

Once tested, restore economy setting.

If heating demand is high, target will increase over time to satisfy heat load.

To reduce potential for condensing, control will allow boiler to heat to 125°F prior to energizing the circulator.

16.8 How Thermal Targeting Works

Thermal targeting technology analyzes thermostat activity and continually evaluates how much heat the house requires.

When it is very cold outside, heat demand is high and limit control will raise boiler's target temperature to provide heat.

When outside temperature is mild, heat demand is low. Limit control will lower boiler's target temperature saving fuel.

Figure 36 - LED Legend

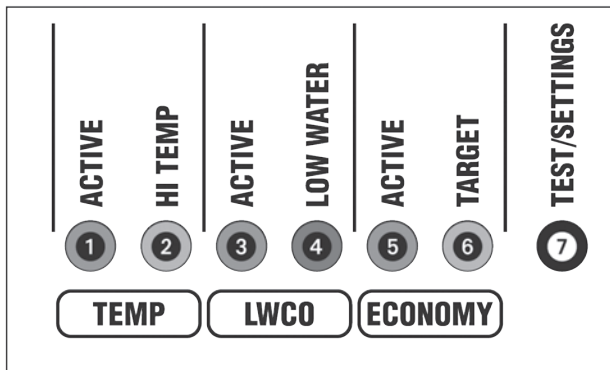

1 **TEMP ACTIVE** Indicates Limit Control is powered and temperature function is active.

2 **TEMP HI TEMP** Illuminates when boiler water temperature reaches high limit setting. Remains lit until water temperature falls 10°F. Limit control prevents burner operation while this LED is on. See Differential explanation page 27.

3 **LWCO ACTIVE** Indicates low water cut-off (LWCO) function of limit control is active. Boiler is factory equipped with Hydrolevel electro-well, enabling control's low water cut-off function. LED will be on at all times when control is powered. Important: If control well is replaced with a well other than Electro-Well, LED will not illuminate indicating control is not providing low water cut-off functionality.

⚠ WARNING
 Burn and scald hazard. Do not add water until boiler has fully cooled. Failure to follow these instructions could result in death or serious injury.

4 **LWCO LOW WATER** Illuminates if boiler is in low water condition. Limit control will prevent burner operation during this condition. Important: System must be checked by a qualified service agency prior to resuming operation.

5 **ECONOMY ACTIVE** Indicates thermal targeting function is active and limit control will reduce boiler temperature to conserve fuel. Economy feature is activated using the Economy dial. See "How Thermal Targeting Works" this page.

6 **ECONOMY TARGET** Economy feature is active, limit control continually sets target temperatures below high limit setting to maximize fuel efficiency. When boiler water reaches target temperature, LED illuminates and burner shuts down. Boiler water will continue to circulate and heat the house as long as thermostat call continues. LED will stay lit until boiler temperature drops below differential set point at which point boiler will be allowed to fire again. Note: LED illuminates regularly during normal boiler operation.

7 **TEST/SETTINGS** Button
To Test Low Water Cut-Off: Press and hold Test/Settings button for 5 seconds. Display will read LCO.
LWCO TEST LCO

Red Low Water light should illuminate and burner circuit (B1 and B2) should de-energize. Note: Control must be installed with Electro-Well for low water cut-off functionality.

To View Current Settings: Press and release Test/Settings button in short intervals to sequentially display the following settings:

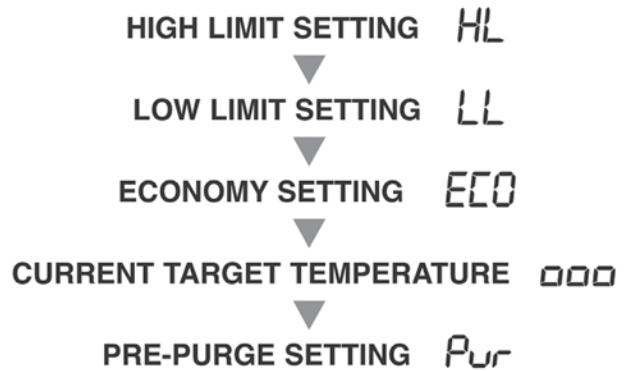

Display will return to boiler temperature (default) if Test/Settings button is not pressed for 5 seconds.

NOTICE

Instructions are for Beckett AFG with Beckett Genisys primary control. For other burners, refer to manufacturer's manual.

Nozzle and air settings for approved burners are provided in Tables 13-17.

For direct vent installation guide, see Direct Vent Addendum.

16.9 Oil Burner

1. Prepare Oil Burner Before Starting.

- A. Check burner air band, air shutter and head setting (if equipped), readjust if necessary. See "17 - Oil Burner, Nozzle, & Air Settings" .
- B. Open all oil line valves.
- C. Attach a plastic hose to fuel pump vent fitting and provide a pan to catch the oil.

2. Prime Pump and Start Oil Burner

- A. Open bleed port fitting on fuel pump.
- B. Initiate a call for heat
 - I. After burner starts, press and hold reset button for approximately 15 seconds until yellow light turns on. Indicates button has been pressed long enough.
 - II. Release reset button. Yellow light turns off and burner starts up again.
 - III. At burner startup, click reset button while igniter is still on. This transitions control to dedicated pump priming mode, during which the motor, igniter and valve are powered for four minutes. Yellow light will be on.
- C. Bleed pump until all froth and bubbles are purged.
 - I. If desired, terminate call for heat or hold reset button for at least one second to exit pump priming mode and return to standby mode.
 - II. At end of four minutes, yellow light will turn off and control will automatically return to standby mode.
 - III. If prime is not established during four minute pump priming mode, return to step 2.B.III. to re-enter pump priming mode. Repeat steps 2.C.I. to 2.C.II. until pump is fully primed and oil is free of bubbles.
- D. Terminate call for heat. Close bleed port fitting on fuel pump.
- E. Adjust oil pressure.
 - I. When checking fuel unit's operating pressure, reliable pressure gauge may be installed in either bleeder port or nozzle port.
 - II. Initiate call for heat.
 - III. Locate oil pressure adjusting screw and turn screw to obtain proper pump pressure, refer to "17 - Oil Burner, Nozzle, & Air Settings".

⚠ WARNING

Fire, burn, asphyxiation hazard. Do not loosen or remove any oil line fittings while burner is in operation. Failure to follow these instructions could result in death or serious injury.

⚠ WARNING

Fire, burn, asphyxiation hazard. Do not attempt to start burner when oil has accumulated in combustion chamber or unit is full of vapor, or hot. Check operation of all boiler controls before installation of boiler is completed. Failure to follow these instructions could result in death or serious injury.

3. Preliminary Oil Burner Adjustments

- A. Adjust Draft Regulator for breech draft of -0.05 (preferred) to 0 inches water column after chimney has reached operating temperature and while burner is running.
- B. Use smoke tester and adjust air if necessary for minimum smoke (not to exceed trace) with minimum of excess air. Check using suitable instrumentation to confirm CO₂ of 11 to 13%. If flame appears stringy instead of solid fire, try another nozzle of same type. Flame should be solid and compact.
- C. Turn off burner and remove pressure gauge. Install gauge port/bleeder plug and tighten. Start burner again.

4. Final Burner Adjustments: Final burner adjustments must be made using combustion test instruments.

- A. Check breech draft to verify between 0.00" WC and -0.05" WC, or otherwise adjust draft to -0.05" WC (or less than zero.)
- B. After operating 10 minutes to warm up boiler, use combustion test equipment to take smoke reading in flue pipe between boiler and draft regulator. Smoke reading should be zero to trace (Shell Bacharach Scale).
- C. New boiler may require more than 10 minutes to burn clean due to oil film on new heat exchanger. If smoke reading is zero, gradually close burner's air adjustment to obtain smoke reading showing trace smoke reading. Once smoke reading is trace, measure CO₂ and as insurance margin increase air to sufficiently reduce CO₂ by 1/2% to 1%.
- D. If clean fire cannot be obtained, it is necessary to verify burner head alignment. If fire continues to be smoky, replace nozzle.

16 - OPERATING THE BOILER - SYSTEM START-UP

⚠ CAUTION

Do not run boiler unattended until following procedure is completed. Failure to follow these instructions could result in minor or moderate injury.

- E. Once burner is completely adjusted, start and stop burner several times to assure good operation with no fluttering or rumbling. Verify there are no oil leaks, record nozzle size, oil pressure, combustion readings, and air settings on tag or label attached to burner or boiler.

⚠ WARNING

Electrical shock hazard. Following safety checks shall be completed by qualified agency. Failure to do so could result in death or serious injury.

NOTICE

Control contains no field serviceable parts. Do not attempt to take it apart. Replace entire control if operation is not as described.

5. Check Genisys Oil Primary Control

A. Preliminary steps

- I. Check wiring connections and power supply.
- II. Verify power is on to controls.
- III. Verify limit control is closed.
- IV. Check contacts between igniter and electrodes.
- V. Check piping to oil tank.

B. Safe Start Check

- I. Place jumper across cad cell terminals.
- II. Initiate call for heat.
- III. Burner must not start. Verify green light is on continuously and control remains in standby
- IV. End call for heat and remove cad cell jumper.

C. Simulate Flame Failure And Ignition Failure mode.

- I. Initiate call for heat.
- II. After flame is established and burner igniter turns off, close hand valve in oil supply line.
- III. At flame loss, control will enter recycle mode. Verify green light is flashing. Control will remain in recycle for 60 seconds.

- IV. After 60 second recycle period, control will try to restart system.
- V. After 15 second lockout time, control will lock out burner and reset button will flash. Verify burner, motor and igniter are off and burner solenoid valve (if used) is not energized.
- VI. Open hand valve in oil line.
- VII. Click reset button and verify red light in reset button shuts off and burner lights.
- VIII. End call for heat.

Figure 37 - CAD Cell Location

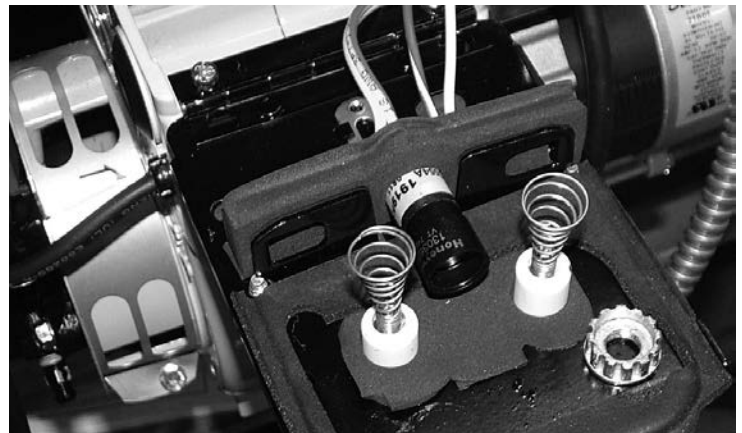

- D. Cad Cell Check :** Cad cell resistance can be checked with use of Genisys display module or Genisys contractor tool. If not available, cad cell leads can be unplugged from control and resistance measured in conventional way. Conduct these tests with flame present. See Figure 37.

Flame Detection Range

- Normal (0-1600 ohms)
- Limited (1600 ohms to lockout)

- E. Power Failure Check:** After flame is established, turn power off to control / burner. Burner should shut down safely. When power is restored, normal ignition sequence should be started.

Figure 38 - Sequence of Operation

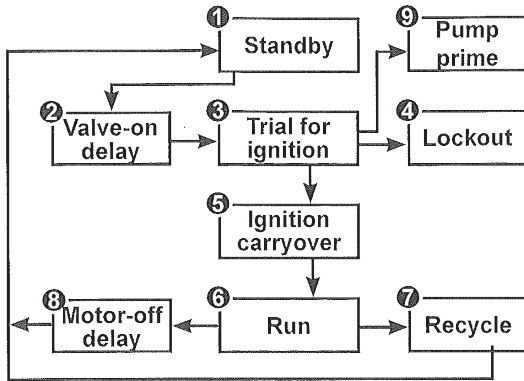

6. Genisys Control Sequence of Operation

- A. **Standby.** Burner is idle, waiting for call for heat.
- B. **Valve-On Delay.** Igniter and motor are on while control delays turning on oil solenoid valve for programmed time.
- C. **Trial for Ignition.** Oil solenoid valve is energized. Flame should be established within factory set trial for ignition time ("lockout time").
- D. **Lockout.** Control has shut down for one of following safety reasons:
 - I. Trial for ignition (lockout) time expired without flame being established.
 - II. Cad cell detected flame at end of Valve On Delay State.
To reset from hard lockout, hold reset button 15 seconds until yellow light turns on.

- E. **Ignition Carry-over.** Once flame is established, igniter remains on for 10 additional seconds to ensure flame stability.
- F. **Run.** Flame is sustained until call for heat is satisfied. Burner is then sent to Motor-Off Delay, if applicable, or it is shut down and sent to Standby.
- G. **Recycle.** If flame is lost while burner is firing, control shuts down burner, enters 60 second recycle delay, and repeats ignition sequence. Control will continue to recycle each time flame is lost, until it reaches preset time allotment. Control will then go into Hard Lockout instead of recycle. Feature prevents excessive accumulation of oil in the boiler firing chamber.
- H. **Motor-Off Delay.** If applicable, oil solenoid valve is turned off and control delays turning motor off for set motor-off delay time before control returns to standby.
- I. **Pump Prime.** Igniter and motor are on with solenoid valve energized for 4 minutes. During Pump Prime mode, cad cell is disregarded, allowing technician to prime pump without having to jumper cad cell.

7. Genisys Control Reset Button Operation

See Table 11 for action control takes when reset button is pressed for different lengths of time during various burner operation states.

Table 10 - Genisys Control Reset Button Operation

If burner is in below state:	Pushing reset button will:		
	Button Click (press < 1 second)	Button Hold (press > 1 second)	Button Hold (press 15+ seconds)
Lockout	Reset from Soft Lockout		Reset from Restricted (Hard) Lockout
Valve-on Delay, Trial for Ignition, Ignition Carry-over	Go to Pump Prime See "Priming the Pump" page 44	Disable Burner: Anytime burner is running, press and hold reset button to disable burner. Burner will remain off as long as button is held.	Enables Pump Priming: After reset button has been held for 15 seconds, button can then be clicked during next ignition sequence to enter Pump Prime mode.
Run (Igniter shut off)	No Action		
Motor-Off Delay, Standby	No Action		
Pump Prime	No Action	Exit Pump Prime mode and return to Standby	

Table 11 - Genisys Control Status Lights

Light Color	On Continuously	On Continuously
Red	Restricted (Hard) Lockout	Soft Lockout
Green	Flame Sensed during normal operation (Possible stray light during standby)	Recycle
Yellow	Control is in Pump Prime mode or reset button currently held for 15+ seconds.	N/A

NOTICE

Before starting or resetting control from restricted lockout state, troubleshoot heating system for root cause(s) of lockout.

8. Genisys Control - Resetting From Restricted or Hard Lockout.

- A. Make necessary repairs or adjustment to ensure safe start condition.
- B. Ensure appliance is free of oil and oil vapors before starting or resetting burner
- C. If control continues to lock out without satisfied call for heat, or fails motor relay check, control enters Hard (restricted) Lockout in order to limit accumulation of unburned oil in combustion chamber.
- D. To reset, hold button down for 15 seconds until red light turns off and yellow light turns on.
- E. Always verify control functions according to specifications before leaving installation site.
- F. Replace control if it does not operate as specified.

9. Genisys Control - Disable Function

Anytime burner is running, press and hold reset button to disable burner. Burner will remain off as long as button is held.

WARNING

Remove jumper after following check.

16.10 Check High Temperature Limit Control.

Jumper thermostat terminals. Allow burner to operate until shut down by limit. Installation is not considered complete until this check has been made.

16.11 Test Low Water Cut-Off Operation. See Figure 36.

16.12 If Controls Do Not Meet Requirements

replace control and repeat checkout procedures.

16.13 Nozzles And Electrodes: Use proper size, spray angle, and spray pattern nozzle.

- A. Refer to "17 - Oil Burner, Nozzle, & Air Settings" .
- B. To install nozzle, remove nozzle line electrode assembly, if necessary remove retention ring assembly, install and tighten nozzle. Be careful not to damage electrode insulators or bend electrode tips.

- C. After installing nozzle, reassemble nozzle line electrode assembly and set electrode tip spacing.
- D. Electrode tip spacing may need to be set prior to reassembling nozzle line electrode assembly. Refer to figures on following pages for setting electrode tip spacing on Beckett.

16.14 Check Thermostat Operation: Thermostat location has important effect on operation of boiler system.

- A. Follow instructions included with your thermostat. Typically, thermostat is located about five feet above floor on inside wall.
- B. Thermostat should be located to sense average room temperature.

Table 12 - Thermostat locations to Avoid

DEAD SPOTS	HOT SPOTS	COLD SPOTS
Behind doors	Concealed pipes	Concealed pipes or ducts
	Fireplace	
	TV sets	Stairwell drafts
Corners & alcoves	Radios	Door drafts
	Lamps	Unheated room on other side of wall
	Direct sunlight	
	Kitchens	

- C. Verify room temperature reaches selected temperature setting, thermostat should turn boiler's burner off, and once room temperature falls few degrees boiler starts operating again.

Figure 39 - Beckett NX Electrode Tip Adjustments for Three Pass Boilers

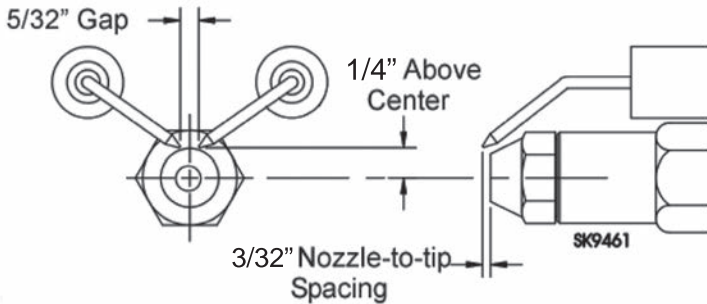

For detailed setup and adjustment instructions for Beckett NX Oil Burner, refer to Beckett NX Oil Burner Manual provided with boiler.

Figure 40 - Beckett AFG Electrode Tip Adjustments for Three Pass Boilers

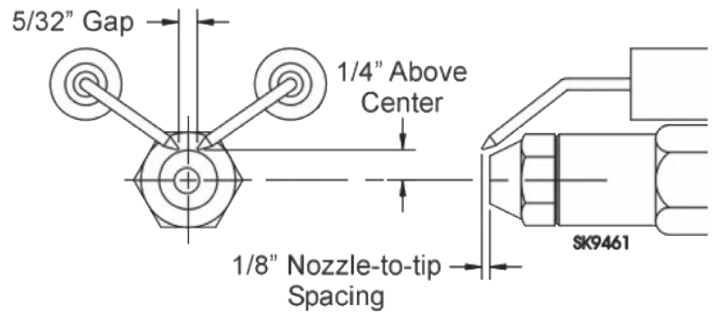
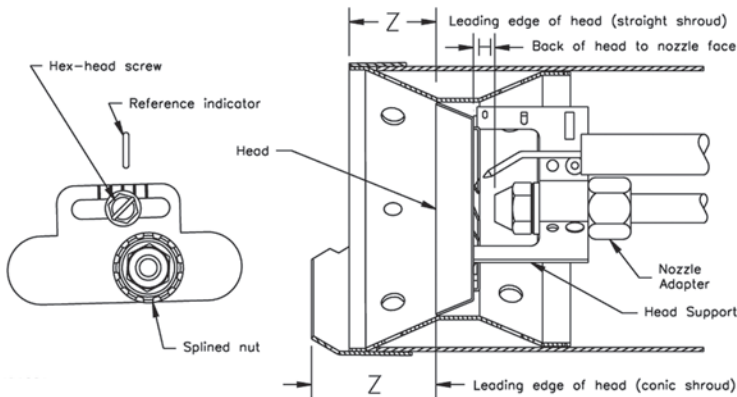

Figure 41 - Beckett AFG Check/Adjustment "Z" Dimensions L1 & L2 Heads



AFG Burner with L1/L2 Heads

See Figures 40 and 41. The important "Z" dimension is distance from leading edge of head to end of air tube. This distance for L1 & L2 heads is 1-3/8" if the tube has a straight shroud or 1-3/4" if air tube has conic shroud. "Z" dimension is factory set for burners shipped with air tube installed. Even if factory set, verify "Z" dimension has not been changed.

1. Use following procedure to adjust "Z" dimension, if it is not correct:
 - Turn off power to burner.
 - Disconnect oil connector tube from nozzle line.
 - Refer to figure above. Loosen splined nut from nozzle line. Loosen hex head screw securing escutcheon plate to burner housing.
 - Place end of ruler at leading edge of head and, using straight edge across end of airtube, measure distance to end of tube. A Beckett T501 gauge may also be used.
 - Slide nozzle line forward or back until this dimension is 1-3/8" for L1 & L2 heads if tube has straight shroud, or 1-3/4" if air tube has conic shroud.
 - Tighten hex head screw to secure escutcheon plate to burner chassis. Then tighten splined nut and attach oil connector tube.
2. Recheck "Z" dimension periodically when servicing to ensure escutcheon plate has not been moved. Reset "Z" dimension if you replace air tube or nozzle line assembly.

Figure 42 Beckett AFG Check/Adjustment "Z" Dimensions - V1 Heads

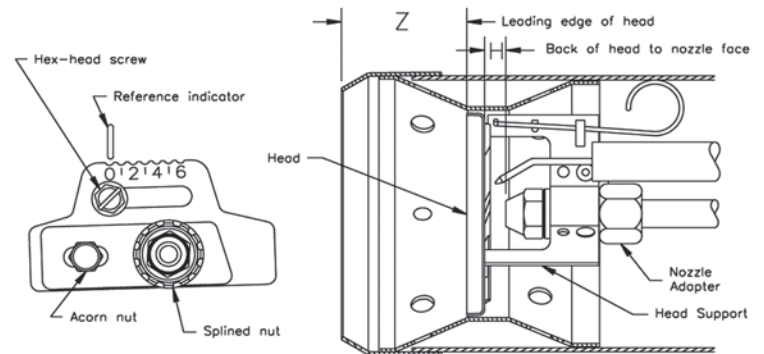

AFG Burner with V1 Heads

See Figures 40 and 42. The important "Z" dimension is distance from leading edge of head to end of air tube. This distance for V1 heads is 1-3/4". "Z" dimension is factory set for burners shipped with air tube installed. Even if factory set, verify "Z" dimension has not been changed.

1. Use following procedure to adjust "Z" dimension, if it is not correct:
 - Turn off power to burner.
 - Disconnect oil connector tube from nozzle line. Refer to figure above. Loosen splined nut from nozzle line. Loosen hex head screw securing escutcheon plate to burner housing.
 - Loosen acorn nut. Move head adjusting plate until "0" lines up with reference indicator on housing, and tighten hex head screw. Place end of ruler at leading edge of head and, using straight edge across end of air tube, measure distance to end of tube. A Beckett T501 gauge may also be used.
 - Slide the nozzle line forward or back until this dimension is 1-3/4" for V1 heads. Tighten acorn nut.
 - Tighten hex head screw to secure head adjusting plate to burner chassis. Then tighten splined nut and attach oil connector tube.
2. Recheck "Z" dimension periodically when servicing to ensure escutcheon plate has not been moved. Reset "Z" dimension if you replace air tube or nozzle line assembly.

Figure 43 - Riello Electrode Setting

IMPORTANT: THESE DIMENSIONS MUST BE OBSERVED AND VERIFIED.

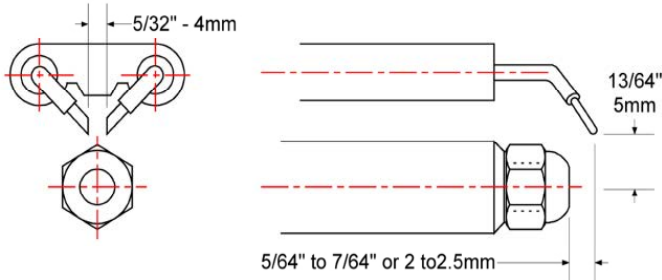
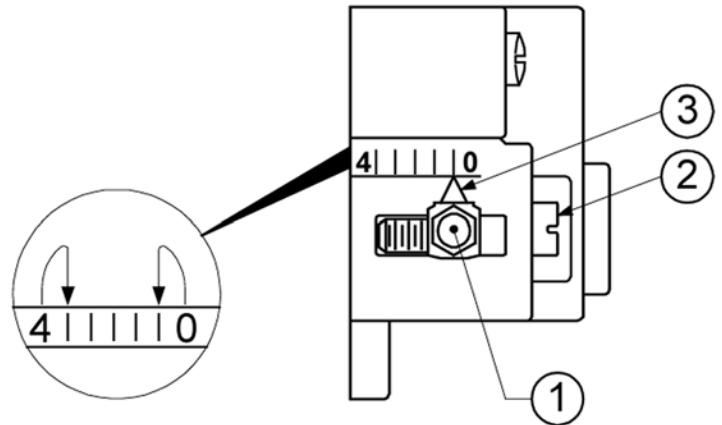

Figure 44 - Riello Turbulator Setting



Turbulator Setting

A. Loosen nut (1) turn SCREW (2) until INDEX MARKER (3) is aligned with correct index number as per Burner Settings Table.

B. Tighten RETAINING NUT (1).

NOTE: Zero and four are scale indicators only.

From left to right, first line is 4 and last line 0. On some models, scale indicators are 0 and 3.

Figure 45 - Carlin Electrode Setting

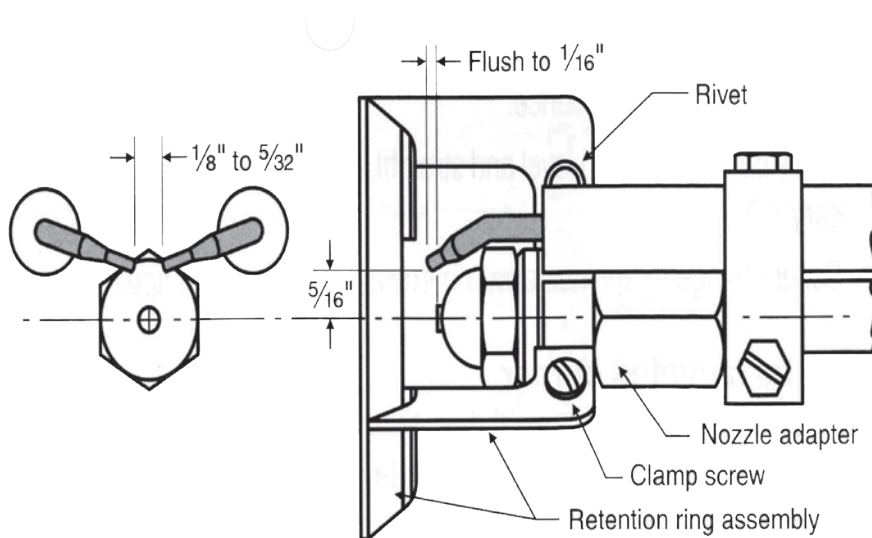

17 - OIL BURNER, NOZZLE, & AIR SETTINGS

Table 13 - Beckett Chimney Vent Preliminary Burner Settings

Burner settings provided are for initial startup only. Final adjustments must be made using combustion test instruments.

TABLE 13a : BECKETT CHIMNEY VENT PRELIMINARY BURNER SETTINGS												
Boiler Model	Head Type	Static Plate	Insertion Depth	Firing Rate [GPH]	Combustion Liner	Nozzle Mfr.	Nozzle Type	Pump Pressure [PSI]	Head Setting	Air Band	Air Shutter	Rated AFUE Efficiency [%]
4075	L2	3.375U	2.625"	0.75	Oval	Delavan	0.65x60B	140	N/A	0	7	87.0
4090	L2	3.375U	2.625"	0.90	Oval	Delavan	0.75x60B	140	N/A	0	10	86.0
5100	L2	3.375U	2.625"	1.00	None	Delavan	0.85x60B	140	N/A	2	10	87.0
6130	V1	2.75M	2.625"	1.30	V6	Delavan	1.10x60B	140	0	1	10	87.0
7165	V1	2.75M	2.625"	1.65	V7	Delavan	1.25x45B	175	3	4	10	87.0
Timings												
Pre-purge		15 seconds										
Post-purge		15 seconds										

TABLE 13B: BECKETT /ECR PART NUMBERS			
Boiler Model	Beckett Oil Burner Model	ECR Oil Burner Part Number with Cover	ECR Oil Burner Part Number Less Cover
4075	AFG70MQASN	240007144	240007232
4090	AFG70MQASN	240013302	240013303
5100	AFG70MQASN	240007145	240007233
6130	AFG70MKAQN	240007146	240007234
7165	AFG70MKAQN	240007183	240007235

17 - OIL BURNER, NOZZLE, & AIR SETTINGS

Table 14 - Beckett NX (Direct Vent) Preliminary Burner Settings

Burner settings provided are for initial startup only. Final adjustments must be made using combustion test instruments.

TABLE 14a: BECKETT DIRECT VENT PRELIMINARY BURNER SETTINGS									
Boiler Model	Head Type	Insertion Depth	Firing Rate [GPH]	Combustion Liner	Nozzle Mfr.	Nozzle Type	Pump Pressure [PSI]	Air Setting	Pressure Switch Setpoint
4075	6 Slot	2.5"	0.75	Oval	Delavan	0.60x60B	150	1.5	0.65" WC
5100	6 Slot	2.5"	1.00	None	Delavan	0.75x45B	175	4.0	0.85" WC
6130	6 Slot	2.5"	1.30	V6	Delavan	1.00x45B	175	2.0	0.65" WC
Timings									
Pre-purge		15 seconds							
Post-purge		30 seconds							

TABLE 14b : BECKETT / ECR PART NUMBERS		
Boiler Model	Beckett Oil Burner	ECR Oil Burner Part Number
4075	NX70LC	550004238
5100	NX70LC	240007532
6130	NX70LD	240007533

17 - OIL BURNER, NOZZLE, & AIR SETTINGS

Table 15 - Riello 40F Chimney Vent Preliminary Burner Settings

Burner settings provided are for initial startup only. Final adjustments must be made using combustion test instruments.

TABLE 15: RIELLO 40F CHIMNEY VENT PRELIMINARY BURNER SETTINGS										
Boiler Model	Head Type	Insertion Depth	Firing Rate [GPH]	Combustion Liner	Nozzle Mfr.	Nozzle Type	Pump Pressure [PSI]	Head Setting	Air Setting	Rated AFUE Efficiency [%]
4075	Reverse	2.75"	0.75	Oval	Delavan	0.65x60W	150	1	3.6	87.0
4090	Reverse	2.75"	0.90	Oval	Delavan	0.75x90B	140	2	3.5	86.0
5100	Standard	2.75"	1.00	None	Delavan	0.75x60B	175	1	2.4	87.0
6130	Standard	2.75"	1.30	V6	Delavan	1.00x45B	175	2	3.6	87.0
7165	Standard	2.75"	1.65	V7	Delavan	1.35x60B	150	4	8.0	87.0
Timings										
Pre-purge		12 seconds								

Boiler Model	Riello Oil Burner Model	ECR Oil Burner Part Number
4075	40F3	550003548
4090	40F3	550004237
5100	40F5	550003551

Boiler Model	Riello Oil Burner Model	ECR Oil Burner Part Number
6130	40F5	550003554
7165	40F5	550003557

17 - OIL BURNER, NOZZLE, & AIR SETTINGS

Table 16 - Riello 40F (DIRECT VENT) Preliminary Burner Settings

Burner settings provided are for initial startup only. Final adjustments must be made using combustion test instruments.

Table 16 : RIELLO 40BF DIRECT VENT PRELIMINARY BURNER SETTINGS										
Boiler Model	Head Type	Insertion Depth	Firing Rate [GPH]	Combustion Liner	Nozzle Mfr.	Nozzle Type	Pump Pressure [PSI]	Head Setting	Air Setting	Pressure Switch Setpoint
4075	Reverse	2.75"	0.75	Oval	Delavan	0.65x60W	150	3	5.0	0.25" WC
5100	Standard	2.75"	1.00	None	Delavan	0.75x60B	175	1	5.0	0.80" WC
6130	Standard	2.75"	1.30	V6	Delavan	1.10x70B	145	3	8.0	0.90" WC
Timings										
Pre-purge	12 seconds									
Post-purge	30 seconds									

Boiler Model	Riello Oil Burner Model	ECR Oil Burner Part Number
4075	40BF3	550004239
5100	40BF5	550003563
6130	40BF5	550003566

17 - OIL BURNER, NOZZLE, & AIR SETTINGS

Table 17 - Carlin (CHIMNEY VENT) Preliminary Burner Settings

Burner settings provided are for initial startup only. Final adjustments must be made using combustion test instruments.

Table 17- CARLIN CHIMNEY VENT PRELIMINARY BURNER SETTINGS

Boiler Model	Insertion Depth	Firing Rate	Combustion Liner	Nozzle Mfr.	Nozzle Type	Pump Pressure [PSI]	Head Bar Setting	Air Band Setting	Rated AFUE Efficiency [%]
4075	4.56"	0.75	OVAL	DELAVAN	0.60x60B	160	1	22%	87.0
4090	4.56"	0.90	OVAL	DELAVAN	0.75x70A	145	2	28%	86.0
5100	3.00"	1.00	NONE	HAGO	0.75x60B	175	0.75	35%	87.0
Timings									
Pre-purge		15 seconds							
Post-purge		15 seconds							

Boiler Model	Carlin Oil Burner Model	ECR Oil Burner Part Number
4075	EZ-SELECT	240013299
4090	EZ-SELECT	240013299
5100	EZ-LF	240013304

⚠ DANGER

Before servicing, turn off electrical power to boiler at service switch. Turn off fuel supply to burner. Failure to comply will result in death or serious injury.

NOTICE

Perform regular service and maintenance by qualified service agency at least once every 12 months to assure safe, trouble free operation and maximum efficiency.

NOTICE

Verify proper operation after servicing.

18.1 Annually

Recommend qualified Service Agency check at least once a year:

- Flue passages,
- Combustion chamber area (target wall, fire door insulation)
- Burner adjustment,
- Operation of the controls,
- Boiler seals (fire door gasket or silicone seal, cast iron sectional seals, flue collector)

Before start of each heating season (or system has been shut down for extended period of time)

- Recheck whole system for water, oil, and vent piping leaks.
- Replace or patch any leaks or seals that are faulty
- Inspect flue ways at least once a year- Preferably at start of heating season.
- Inside of combustion chamber.
- Clean vent system and boiler flue ways if soot or scale has accumulated. When cleaning, take precaution to avoid damage to burner swing door insulation. If damaged, or if there is evidence of previous damage, burner swing door insulation must be replaced immediately.
- Oil Burner and controls.

18.2 Vent Pipe

Visually inspect entire venting system once a month for any signs of leakage, deterioration, or soot build up.

If vent pipe shows any signs of leaking or deterioration, replace it immediately.

If it shows any signs of soot build up, clean vent pipe and have burner settings and combustion checked by qualified service agency.

18.3 Relief Valve

- Test relief valve for proper operation. Refer to valve manufacturer's instructions packaged with relief valve.

18.4 Conventional Expansion Tank

See "Equipment And Accessories" section.

18.5 Diaphragm Expansion Tank

See " 21 Equipment And Accessories" section, page 59.

18.6 WATER SYSTEM

Drain system completely if system is to remain out of service during freezing weather. Water left in system will freeze and crack pipes and/or boiler.

18.7 Oil Burner Maintenance

Perform following preventative maintenance annually, preferably prior to heating season.

- **Fuel Filter** Replace to prevent contaminated fuel from reaching nozzle. Partially blocked fuel filter can cause premature failure of fuel pump.
- **Fuel Pump Unit** Replace pump screen and clean pump unit to maintain fuel delivery to nozzle.
- **Ignition Electrodes** Clean and adjust as per manufacturer's recommendations, so as to maintain reliable ignition of oil.
- **Nozzle** Replace so as to maintain safe and reliable combustion efficiency. Always replace with exact nozzle as required in charts. See "17 - Oil Burner, Nozzle, & Air Settings" on page 31.
- **Fan and Blower Housing** Keep clean, free of dirt, lint and oil to maintain proper amount of air fuel requires to burn.
- **Check burner settings and adjust as needed.**

NOTE: *If any component parts must be replaced, always use parts recommended by burner manufacturer.*

18.8 Low Water Cut Off Maintenance

⚠ WARNING

Burn and scald hazard. Verify boiler is at zero pressure before removing relief valve or control well. Open safety valve to relieve all internal pressure prior to proceeding.

Remove control well from top of rear boiler section every five years and clean any scale or sediment deposits from all parts exposed to boiler water.

Steps to inspect, clean and/or replace control well:

1. Turn off electric service to boiler controls.
2. Drain boiler water to level below tapping for control well.
3. Remove low water cut-off/limit sensor from control well.
4. Unscrew control well from tapping.
5. Inspect portion of control well exposed to water for scale or sediment buildup.
6. Light deposits may be removed by wiping control well with damp cloth. Wiping probe with cloth soaked in vinegar will remove more tenacious lime deposits.
7. Clean pipe threads of probe to remove old, hardened pipe dope and other foreign matter.
8. Apply moderate amount of good quality pipe dope to pipe threads on control well, leaving two end threads bare. Do not use PTFE (Teflon) tape.
9. Reinstall control well into tapping.
10. Reinsert low water cutoff/limit sensor in control well and secure with grommet.
11. Fill system with water and purge.
12. Restore electric service to boiler.
13. Fire burner to heat water in boiler 180°F to drive off free oxygen.
14. Warning – before returning boiler to service: Follow low water cut-off test procedure in Figure 36, Page 41.

18.9 Boiler And System Cleaning Instructions For Trouble Free Operation

1. Boiler and system (other than expansion tank) must be full of water for satisfactory operation. Add water to system until boiler pressure gauge registers 12 psi. Water should come out of all air vents when opened.
2. Wash Oil and grease which accumulate in new hot water boiler out in following manner:
 - Shut off valves that have been installed between boiler return manifold and system, to minimize amount of system draining.
 - Drain boiler to level below relief valve tapping.
 - Remove relief valve using extreme care to avoid damaging it.
 - Add appropriate amount of recommended boil out compound.
 - Replace relief valve.
 - Fill entire system with water and purge.
 - Start firing boiler.
 - Circulate water through entire system.
 - Vent system, including radiation.
 - Allow boiler water to reach operating temperature, if possible.

- Continue to circulate water for few hours.
 - Stop firing boiler.
 - Drain system in a manner and to a location that hot water can be discharged safely.
 - Remove plugs from all available returns and wash water side of boiler as thoroughly as possible, using high-pressure water stream.
 - Refill system with fresh water.
3. Add appropriate boiler water treatment compounds as recommended by your qualified water treatment company.
 4. Testing pH /alkalinity. After boiler and system have been cleaned and refilled as previously described, test pH of water in system. Use pH test kit. pH should be higher than 7 but lower than 11. Add appropriate water treatment chemicals, if necessary, to bring pH within range. Care must be exercised to eliminate all free oxygen in system.
 5. Boiler is now ready to be put into service.

18.10 Frequent Water Addition

Frequent water additions, although unusual for water boilers, are sign a of leaky system. Excessive amounts of make up water supplied to boiler can significantly shorten life of boiler. Repair leak and consult with your water treatment specialist for recommendations.

18.11 Attention To Boiler While Not In Operation

NOTICE

Fully drain boiler if not used during winter months to prevent freeze damage.

1. Keep manual fuel supply valve shut off if burner is shut down for extended period of time.
2. To recondition heating system in fall season after prolonged shut down, follow instructions outlined in See "15 - Filling boiler".
3. Boiler contains controls which may cause boiler to shut down and not restart without service. If damage due to frozen pipes is a possibility, heating system should not be left unattended in cold weather; or appropriate safeguards and alarms should be installed on heating system to prevent damage if boiler is inoperative.
4. Keep boiler and area around it clean. Never burn refuse or any material other than specified fuel in your boiler. Have your boiler checked each year by qualified service agency.

19 - OIL BOILER / BURNER CLEANING INSTRUCTIONS

DANGER

Before servicing, turn off electrical power to boiler at service switch. Turn off fuel supply to burner. Failure to comply will result in death or serious injury.

WARNING

Fire, burn, asphyxiation hazard. Turn off service switch to boiler to prevent accidental firing of burner outside combustion chamber. Disconnect burner power cord from wire harness in front jacket. Tighten swing door fastener completely when service is complete. Failure to follow instructions in this manual and understand all requirements could result in death or serious injury.

19.1 Oil Boiler Cleaning Instructions

1. **Clean flueways.** See Figure 46.
 - A. Shut off power to burner.
 - B. Access to combustion chamber, remove swing door bolts. If boiler is equipped with flexible fuel line(s), swing door open.
 - C. Remove vent connector.
 - D. Remove liners & baffles (if equipped) from flue passages. Baffles are installed in 3rd pass (two inner flue ways.)
 - E. Clean 3rd Pass – Insert 2" Dia. x 42" long wire or fiber bristle brush into each of two 3rd passes. Using long strokes, push brush all the way through boiler until brush has exited the smoke box opening. Pull brush all the way forward until it has exited front of boiler.
Continue this operation for entire height of flue way until clean. Repeat operation for other 3rd pass flue way.
 - F. Clean 2nd Pass – Insert wire or fiber bristle brush into each of two 2nd passes. Using long strokes, push brush all the way through boiler until brush hits back wall of reversing chamber. Pull brush all the way forward until it has exited front of boiler. Continue operation for entire height of flue way until clean. Repeat operation for other 2nd pass flue way.
 - G. Clean passage from combustion chamber to 2nd pass. Take care not to damage or loosen target wall

2. **Clean combustion chamber and baffles.** Use wire or fiber bristle brush to clean surfaces of combustion chamber and baffles. Vacuum all of loose debris in bottom of combustion chamber. Take care not to damage or loosen target wall.
3. **After cleaning:** Vacuum all remaining debris as necessary. Inspect burner swing door insulation, target wall and rope gasket for signs of damage. If damaged, replace as needed.
4. **Re-assemble boiler.**
 - A. Insert liner and baffles (if equipped) into correct flue way. Baffles are installed in 3rd pass. (Two inner flue ways)
 - B. Inspect chimney and clean if necessary.
 - C. Clean and re-attach vent connector onto rear of the boiler with three screws.

NOTICE

When securing burner swing door verify door is drawn-in equally on both sides. Do not overtighten door bolts. Rope gasket will provide sufficient seal when door is snugged into place.

- D. Tighten swing door hardware to provide adequate seal to rope gasket around perimeter of door. Use alternating tightening method from non-hinged side to hinged side cap screws to pull door tight equally.
- E. Do not start burner unless burner swing door and vent connector are secured in place.

WARNING

Asphyxiation hazard. A clean and unobstructed chimney flue is necessary to allow noxious fumes that could cause injury or loss of life to vent safely. Inspect periodically throughout heating season for any obstructions. Failure to follow instructions in this manual and understand all requirements could result in death or serious injury.

NOTICE

Connect boiler to approved chimney in good condition. Property damage could result if boiler is connected to dirty or inadequate chimney. Inspect interior of chimney flue and clean before start of heating season.

19.2 Oil Burner Cleaning Instructions

Consult burner manufacturer's instructions.

Figure 46 - Cleaning the Boiler

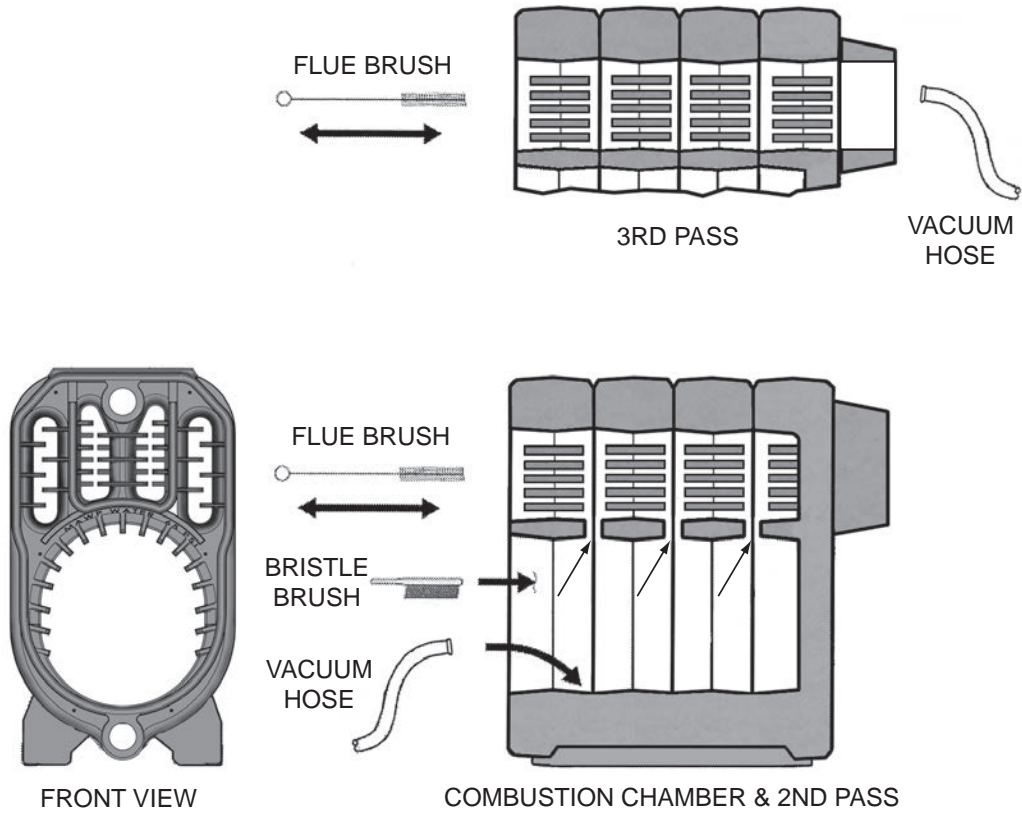

20.1 Combustion

- A. Nozzles** - See "17 - Oil Burner, Nozzle, & Air Settings".
- B. Fuel leaks** - Any fuel leak between pump and nozzle is detrimental to good combustion results. Look for wet surfaces in air tube, under ignitor, and around air inlet. Repair any such leaks as they may cause erratic burning of fuel and in extreme case may become fire hazard.
- C. Dirt** - Fuel filter is required to prevent clogging nozzle or nozzle strainer and produce poor spray pattern from nozzle.
- D. Water** - Water in fuel in large amounts will stall fuel pump. Water in fuel in smaller amounts will cause excessive wear on pump. Water doesn't burn, it chills the flame and causes smoke and unburned fuel to pass out of the combustion chamber and clog flue ways of the boiler.
- E. Cold Oil** - If oil temperature approaching fuel pump is 40°F or cooler, poor combustion or delayed ignition may result. Outside fuel tank above grade or fuel lines in shallow bury may be the cause.
- F. High Altitude Installation** - Air openings must be increased at higher altitudes. Use combustion analyzer and set to 11.5% for initial setting.
- G. Start up noise** - Late ignition is cause of start up noises. If it occurs recheck for electrode settings, flame shape, air or water in fuel lines.
- H. Shut-down noise** - Post Purge timed 15 seconds should eliminate shut-down noise.

C. *Control locks out after trial for Ignition. (TFI)*

- I. No oil to burner.
- II. Shortened electrodes
- III. Clogged nozzles.
- IV. Airflow too high.
- V. Ignitor module defective.
- VI. CAD cell defective.
- VII. Oil valve stuck open or closed.

To isolate fuel problems: disconnect fuel system and fire out of auxiliary container of clean, fresh, warm #2 fuel oil from another source. If burner runs successfully when drawing out of container problem is in fuel or fuel lines.

If flame is not established within 15 seconds of oil valve actuation (known as Trial For Ignition or TFI) soft lockout will occur. Soft lockout is indicated by flashing red LED located on oil primary control.

NOTICE

Restricted lockout without retries will occur if flame is lost three times during one call for heat. this is indicated by a steady on red LED.

20.2 Oil Primary Control

- A. Burner (control) will not come on.**
 - I. No power to control.
 - II. Control is in soft lockout or restricted mode. Press reset button for more than 1 second to exit soft lockout. If control has recycled three times within same call for heat, it will enter into restricted mode. To reset from restricted mode, refer to Section 16.9 for more details.
 - III. CAD Cell seeing light.
 - IV. CAD cell is defective.
- B. Burner (control) will light, then shut down after short time, then restart after one (1) minute.**
 - I. CAD cell is defective.
 - II. Air leaking into oil line causing flame out.
 - III. Defective nozzle causing flame to be erratic.
 - IV. Excessive airflow or draft causing flame to leave burner head.
 - V. Excessive back pressure causing erratic flame.

20 - TROUBLESHOOTING

IF YOUR SYSTEM IS NOT HEATING OR NOT GIVING ENOUGH HEAT . . .

POSSIBLE CAUSE	WHAT TO DO
Thermostat is not set correctly	Reset thermostat
Burner is not operating properly	Adjust burner per instructions.
No electric power to boiler	Check over-current protection. Check to be sure electric power supply circuit is "ON". There may be as many as 3 safety shut-off switches installed. Look for a red plate which may be on the service switch.
Controls out of adjustment	Reset according to instructions.
Circulating pump not running	Check over-current protection. Check relay operation. Check power to circulator.
Poor electrical contact	Check all control terminals and wire joints.
Chimney flue is blocked	Have the chimney professionally cleaned.
RELIEF VALVE LEAKING . . .	
POSSIBLE CAUSE	WHAT TO DO
Corrosion and/or deposits on seat.	Open valve manually. Allow water to run and clear valve seat.
Water logged expansion tank	Drain tank, follow instructions to provide air buffer.
HAVE YOUR SERVICE TECHNICIAN CHECK ANY PROBLEM YOU ARE UNABLE TO CORRECT.	

LIMIT CONTROL TROUBLESHOOTING GUIDE

System Condition	Diagnostic Condition	Check	Action
Boiler is cold, house is cold.	Display off	120 VAC system power	Turn system power on
	Display on	24 VAC T-T	No 24 V; replace control
		24 V present; disconnect thermostat, short T-T	Boiler starts, check wiring and thermostat
		120 VAC at B1-B2	<ul style="list-style-type: none"> • If no, replace • If yes, check burner and wiring
	Low Water status light	<ul style="list-style-type: none"> • If illuminated, find and repair water leak(s). 	
Boiler is hot, house is cold.	Display on	120 VAC at C1-C2	<ul style="list-style-type: none"> • 120 vac at C1-C2, check wiring to pump • Wiring OK, is pump running? • If not, replace pump. • If pump is running, check for trapped air or closed zone valves.
Burner will not turn off.	Display On	Burner wired incorrectly. L1 (black) and Limit (red) are reversed. See wiring diagram for installed burner.	Re-Wire burner.

21.1 Limit Relay Control (provided)

Water temperature limit control in limit relay is adjustable. See Limit instructions for how to set limit temperature.

21.2 Drain Valve (provided)

Drain valve is manually operated valve, means of draining all water from boiler and heating system. Installed in casting below burner door.

21.3 Circulator

- Forced hot water systems require circulator.
- Separate circulator or zone valve is required for each zone, if there are two or more zones. Circulator must have capacity to provide circulation required by heating system.
- Circulator should be connected to supply main and must be wired into boiler's electrical system. "9 - Boiler System Piping" for piping configurations with circulator located on supply main piping using zone circulators or zone valves.
- When piping is arranged with zone circulators and no bypass piping, circulator provided with boiler may be used as zone circulator. Both piping arrangements allow circulator to pump away from expansion tank and show how piping should be arranged to allow heating system to be easily purged of air.
- Circulator can be installed on return side of boiler, if preferred.

21.4 Main Air Vent: (Not Provided)

Before system is filled with water, there is air in pipes and radiation units. Some air will be trapped as system is filled. It is possible to eliminate most of this air through air vents on radiation units. Main air vent will speed and simplify this process. Main air vent should be installed on highest point in supply main.

21.5 Automatic Fill Valve (Not Provided)

Hot water system must be filled with water. Adding new water, when needed can be done manually (by use of hand valve in water supply line). This requires regular attention to system's needs. Automatic fill valve or pressure reducing valve accomplishes this without attention. Install in supply line on hot water boilers only. Valve operates through water pressure differentials. It does not require electrical connection.

21.6 Conventional Expansion Tank (Not Provided)

In a properly assembled system, expanding water flows into an expansion tank.

- Expansion tank should be sized correctly because improperly installed or sized expansion tank may result in frequent lifting of relief valve or other heating system problems.
- It is important to install tank higher than top of boiler. Connecting pipe from boiler to expansion tank shall rise continuously up to expansion tank so that air can rise into expansion tank.
- Expansion tank is partially filled with air. Air compresses as water expands, thus forming an air pressure cushion. This "spring-like" cushion serves to maintain correct operating water pressure regardless of water temperature. This assures a "full measure" of water, even in highest radiation unit of the system.
- Tank also serves as trap for excess air in the system. Air can cause noises in pipes and inefficient circulation in radiators if left in piping system.
- It is possible for a tank to become "waterlogged" (filled with water). It can also become overfilled with air when filling system with new water. Fittings on tank and in line to tank are for bleeding off excess air and water.

21.7 Diaphragm Expansion Tank (Not Provided)

Diaphragm type expansion tank takes place of conventional expansion tank.

- Carefully read instructions packed with your tank assembly. Expansion tank should be sized and installed correctly. Improperly installed or sized expansion tank may result in frequent lifting of relief valve or other heating system problems.
- Tank typically comes with 10-12 psi air charge. Same as pressure produced in system by automatic fill valve set to fill boiler to 10-12 psi with fresh water. When system is first filled, tank will fill partially with water. As water is heated, and system pressure increases, water expands into tank and compresses air in the tank. This compressed air cushion permits water in the system to expand as temperature changes and assures "full measure" of water, even in highest radiation unit of system.
- Diaphragm type expansion tank can be mounted on air purger fitting or at any other convenient place in supply or return line. It is recommended to locate diaphragm type expansion tank in supply line with circulator located after expansion tank. This configuration allows circulator to "pump away" from expansion tank for improved air elimination and system performance.
- Air eliminator fitting or air purger is not provided. Air eliminator fitting or air purger is used to help remove air from system before it reaches radiators. It should be installed in supply line. Air left in system can cause noises in pipes and inefficient circulation in radiators.

Figure 47 - Grundfos Pump Curve

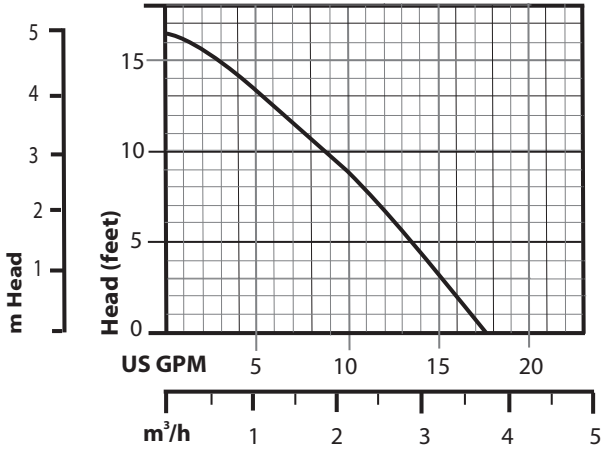

Model	Watts	Volts	Amps	Capacitor
UP 15-42F	85	115	0.74	10 μ F/180 V*

*Fourni avec la pompe

Figure 48 - Taco 007e Pump Curve

007e Performance Curves

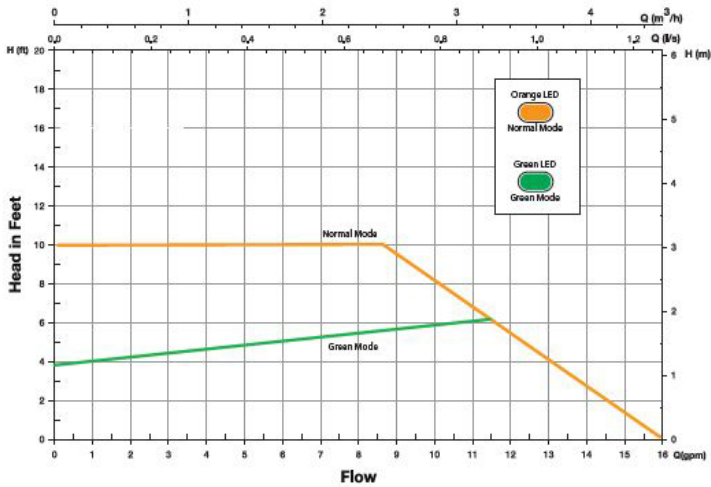

NOTES

INSTALLATION AND CHECK-OUT CERTIFICATE

Boiler Model _____ **Serial #** _____ **Date Installed** _____

Measured BTU/HR input _____

- Installation instructions have been followed**
- Checkout procedure and adjustments performed**
- Maintenance and Service issues reviewed with owner/ maintenance person**
- Installation booklet affixed on or adjacent to boiler**

Installer (Company) _____

Address _____

Phone _____

Installer's Name _____

Signature _____



2201 Dwyer Avenue, Utica, NY 13501

Tel. 800 325-5479

www.ecrinternational.com

All specifications subject to change without notice.

©2020 ECR International, Inc.