



WPSB SERIES 3

GAS-FIRED
HOT WATER BOILERS

INSTALLATION, OPERATION &
MAINTENANCE MANUAL

Models
WPSB-3D
WPSB-3DP
WPSB-4D
WPSB-4DP
WPSB-5D
WPSB-5DP
WPSB-6D
WPSB-6DP
WPSB-7D
WPSB-7DP
WPSB-8D
WPSB-8DP
WPSB-9D
WPSB-9DP









Tested For 50 psi.
ASME
Working Pressure

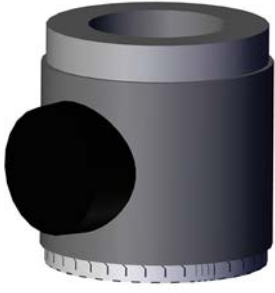

ECR international

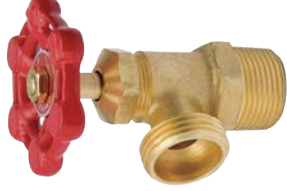
Manufactured by:
ECR International Inc.
2201 Dwyer Avenue, Utica, NY 13501
Tel. 800 253 7900
www.ecrinternational.com
PN 240013090 REV. A [09/30/2020]

ITEMS INCLUDED WITH YOUR BOILER

| | | | |
|---|---|--|---|
|  |  |  |  |
| <p align="center">Fully Assembled Boiler</p> | <p align="center">Vent Damper</p> | <p align="center">Pump (Optional)</p> | <p align="center">*Drain Valve</p> |
|  |  |  |  |
| <p align="center">*ASME Safety Relief Valve</p> | <p align="center">*Tridicator</p> | <p align="center">*Fuse Link w/ Instruction Tag</p> | <p align="center">*Nipple 3/4" x 6-1/2 "</p> |
| <p align="center">Includes Essential Documents and Warranty 11x17 Wire Diagrams</p> | | | |
| <p align="center">Document Package</p> | | | |

* Items found in parts box included with your boiler.

For Parts lists see manual 240013149 included with your boiler literature package.

**KEEP THIS MANUAL NEAR BOILER
RETAIN FOR FUTURE REFERENCE**

Information and specifications outlined in this manual in effect at the time of printing of this manual. reserves the right to discontinue, change specifications or system design at any time without notice and without incurring any obligation, whatsoever.

TABLE OF CONTENTS

| | |
|---|----|
| 1 - Dimensions | 4 |
| 2 - Safety Symbols And Warnings | 5 |
| 3 - Locating The Boiler | 7 |
| 4 - Connecting Supply And Return Piping..... | 9 |
| 5 - Ventilation & Combustion Air | 14 |
| 6 - Chimney And Vent Pipe Connection..... | 15 |
| 7 - Vent Damper Operation | 17 |
| 8 - Gas Supply Piping | 18 |
| 9 - Electrical Wiring..... | 19 |
| 10 - Wiring Diagram..... | 20 |
| 11 - General Instructions | 21 |
| 12 - Lighting Instructions..... | 22 |
| 13 - Operating Your Boiler..... | 23 |
| 14 - Service Hints | 26 |
| 15 - Maintaining Your Boiler | 27 |
| 16 - Boiler Ratings And Capacities..... | 28 |
| Appendix A - Control Function | 29 |
| Appendix A - Control Module | 30 |
| Appendix A-1 - Vent Damper Harness..... | 32 |
| Appendix A-2 - Vent Damper Troubleshooting..... | 33 |

1 - DIMENSIONS

| Dimensions | | | |
|---------------------|--------------------|-----------|----------------------|
| BOILER MODEL NUMBER | DIMENSIONS (INCH.) | | Boiler Volume Gallon |
| | FLUE DIAMETER | "A" WIDTH | |
| WPSB-3 | 5 | 11¼ | 6.3 |
| WPSB-4 | 6 | 14½ | 8.1 |
| WPSB-5 | 6 | 17¾ | 9.9 |
| WPSB-6 | 7 | 21 | 11.7 |
| WPSB-7 | 7 | 24¼ | 13.5 |
| WPSB-8 | 7 | 27½ | 15.3 |
| WPSB-9 | 7 | 30¾ | 17.2 |

Add 5½" to height for vent Damper.

Figure 1 - Dimensions

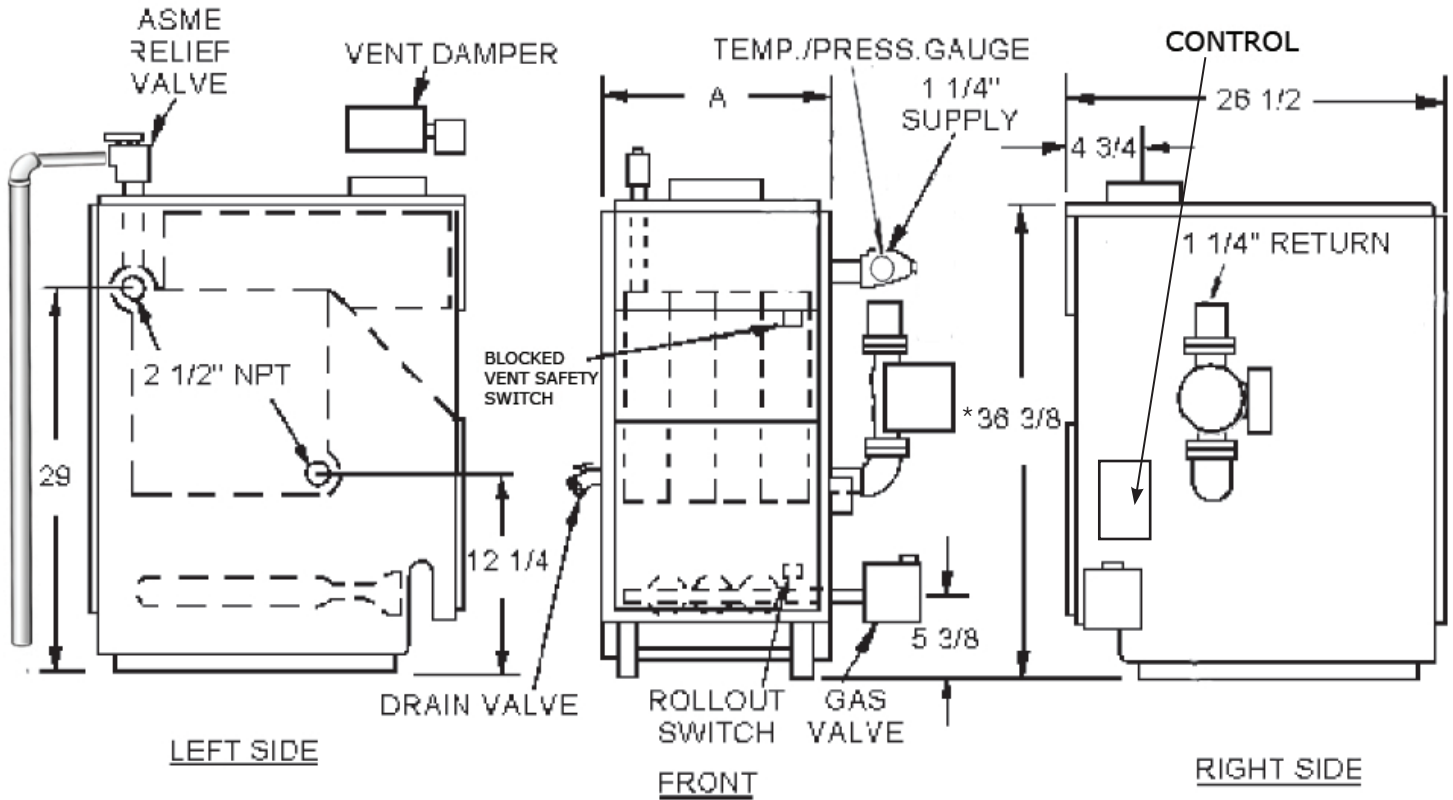

* Minimum acceptable height for Low Water Cutoff probe.

2 - SAFETY SYMBOLS AND WARNINGS

Become familiar with symbols identifying potential hazards.



This is the safety alert symbol. Symbol alerts you to potential personal injury hazards. Obey all safety messages following this symbol to avoid possible injury or death.

DANGER

Indicates a hazardous situation which, if not avoided, **WILL** result in death or serious injury.

WARNING

Indicates a hazardous situation which, if not avoided, could result in death or serious injury.

CAUTION

Indicates a hazardous situation which, if not avoided, could result in minor or moderate injury.

NOTICE

Used to address practices not related to personal injury.

2.1. Safety Information

Boiler installation shall be completed by qualified agency.

WARNING

Fire, explosion, asphyxiation and electrical shock hazard. Improper installation could result in death or serious injury. Read this manual and understand all requirements before beginning installation.

WARNING

Do not tamper with or use this boiler for any purpose other than its intended use. Failure to follow these instructions could result in death or serious injury. Use only manufacturer recommended parts and accessories.

CAUTION

Laceration, burn hazard. Metal edges and parts may have sharp edges and/or may be hot. Use appropriate personal protection equipment to include safety glasses and gloves when installing or servicing this boiler. Failure to follow these instructions could result in minor or moderate injury.

FOR YOUR SAFETY READ BEFORE OPERATING

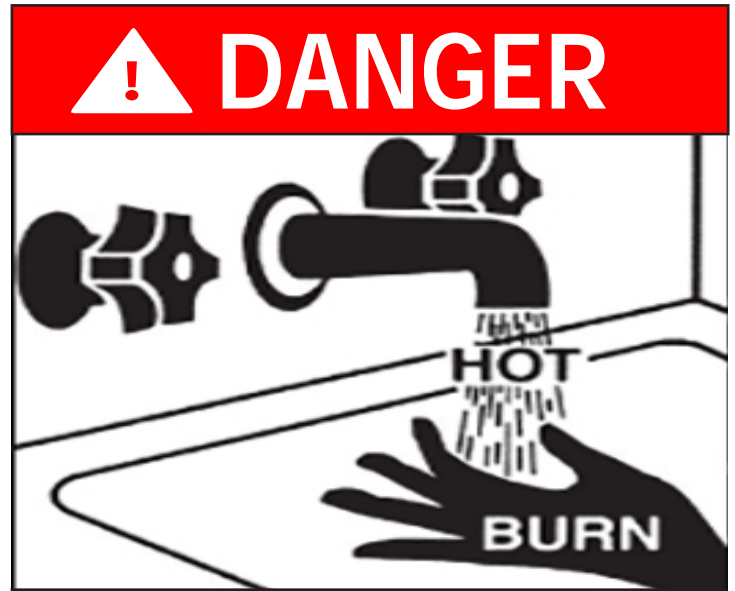

Hot Water Can Scald!

Water heated to temperature for clothes washing, dish washing and other sanitizing needs can scald and cause permanent injury.

Children, elderly, and infirm or physically handicapped persons are more likely to be permanently injured by hot water. Never leave them unattended in bathtub or shower. Never allow small children to use a hot water tap or draw their own bath.

If anyone using hot water in the building fits the above description, or if state laws or local codes require certain water temperatures at hot water taps, you must take special precautions:

- Use lowest possible temperature setting.
- Install some type of tempering device, such as an automatic mixing valve, at hot water tap or water heater. Automatic mixing valve must be selected and installed according to manufacturer's recommendations and instructions.
- Water passing out of drain valves may be extremely hot. To avoid injury:
 - Make sure all connections are tight.
 - Direct water flow away from any person.

| Water Temperature Setting | 1st Degree Burn Exposure Time For An Adult | 2nd and 3rd Degree Burn Exposure Time For An Adult |
|---------------------------|--|--|
| 120° F | 1 minute | 5 minutes |
| 130° F | 5 seconds | 30 seconds |
| 140° F | 2 seconds | 5 seconds |
| 150° F | 1 second | 1.5 seconds |
| 160° F | Instantaneous | 0.5 seconds |

Note: Warning for Infants, Children, and Elderly: Great care must be taken when exposing the aforementioned groups to warm or hot water as they can be badly burned in exposure times less than half of the time for an adult.

2 - SAFETY SYMBOLS AND WARNINGS

WARNING

Combustion chamber insulation in this product contains ceramic fiber material. Ceramic fibers can be converted to cristobalite in very high temperature applications. The International Agency for Research on Cancer (IARC) has concluded, Crystalline silica inhaled in the form of quartz or cristobalite from occupational sources is carcinogenic to humans (Group1). Avoid breathing dust and contact with skin and eyes. Use NIOSH certified dust respirator (N95). This type of respirator is based on the OSHA requirements for cristobalite at the time this document was written. Other types of respirators may be needed depending on the job site conditions. Current NIOSH recommendations can be found on the NIOSH website <https://www.cdc.gov/niosh/topics/silica/>. NIOSH approved respirators, manufacturers, and phone numbers are also listed on this website. Wear long-sleeved, loose fitting clothing, gloves, and eye protection. Apply enough water to the combustion chamber lining to prevent dust. Wash potentially contaminated clothes separately from other clothing. Rinse clothes washer thoroughly.

NIOSH stated First Aid. Eye: Irrigate immediately.
Breathing: Fresh air.

WARNING

Fire, Explosion, Asphyxiation, Electrical shock hazard! Flooding will result in damages such as electrical problems, corrosion, inoperative parts, mold and other unforeseen issues which can occur over time. Any equipment determined by a professional as damaged by a flood, defined as excess of water or other liquid, shall be replaced. Failure to follow these directions will result in a Hazardous Situation.

2.2 For Your Safety

Manufacturer recommends a carbon monoxide detector located on each floor of your home. Follow your detector's instructions for operation and verification. Some jurisdictions may, by law, require.

WARNING

Keep boiler area clear and free from combustible materials, gasoline and other flammable vapors and liquids.

DO NOT obstruct air openings to the boiler room. Modification, substitution or elimination of factory equipped, supplied or specified components may result in personal injury or loss of life.

Installation and service of this boiler shall be performed by a qualified installer.

When this product is installed in the Commonwealth of Massachusetts the installation shall be performed by a Licensed Plumber or Licensed Gas Fitter.

To Installer leave all instructions with boiler for future reference.

3 -LOCATING THE BOILER

⚠ WARNING

Fire hazard. Do not install boiler on combustible flooring or carpeting. Failure to follow these instructions could result in death or serious injury.

⚠ CAUTION

Boiler weight exceeds 200 pounds (90.7 kg). Do not lift boiler without assistance.

3.1 Installation Requirements

1. Installation shall conform to the requirements of the authority having jurisdiction or, in the absence of such requirements, to the National Fuel Gas Code, ANSI Z223.1/NFPA 54, and/or Natural Gas and Propane Installation Code, CAN/CSA B149.1.
2. Where required by the authority having jurisdiction, the installation shall conform to the Standard for Controls and Safety Devices for Automatically fired Boilers, ANSI/ASME CSD-1.
3. Boiler series is classified as a Category I. Vent installation shall be in accordance with "Venting of Equipment", of the National Fuel Gas Code, ANSI Z223.1/NFPA 54, or "Venting Systems and Air Supply for Appliances," of the Natural Gas and Propane Installation Code, CAN/CSA B149.1, or applicable provisions of the local building codes.
4. Boiler has met safe lighting and other performance criteria with the gas manifold and control assembly on the boiler per the latest revision of ANSI Z21.13/CGA 4.9.
5. Install boiler such that gas ignition system components are protected from water (dripping, spraying, rain, etc.) during appliance operation and service, (circulator replacement, condensate trap, control replacement, etc.).
6. Locate boiler on level, solid base as near chimney as possible and centrally located with respect to heat distribution system as practical.
7. Allow 24 inches (610mm) at front and right side for servicing and cleaning.
8. When installed in utility room, door should be wide enough to allow largest boiler part to enter, or to permit replacement of another appliance such as water heater.

9. **FOR INSTALLATION ON NON-COMBUSTIBLE FLOORS ONLY** - For installation on combustible flooring special base shall be used. Please refer to (Combustible Floor Addendum) included in literature envelope provided with boiler and outlined in *National Fuel Gas Code*, ANSI Z223.1/NFPA 54. **Do Not Install Boiler on carpeting.**

Table 2 - MINIMUM CLEARANCE DIMENSIONS

| | Inches | (mm) |
|---------------------|--------|---------|
| Top | 6" | (152mm) |
| Rear | 6" | (152mm) |
| Control Side | 7" | (178mm) |
| Opposite Side | 6" | (152mm) |
| Front | 18" | (457mm) |
| Flue/Vent Connector | 6" | (152mm) |
| Near Boiler Piping | 2" | (51mm) |

NOTE: Greater clearances for access should supersede fire protection clearances.

* Definition of Alcove is three sided space with no wall in front of boiler. ANSI standard for alcove is 18 inches from front of appliance to leading edge of side walls as shown below.

Minimum Clearances to Combustible Construction (as seen from above)

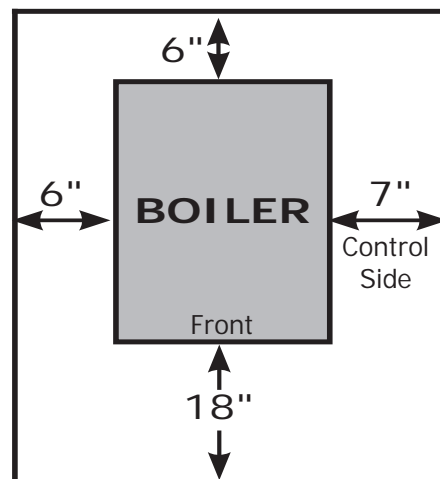

3 - LOCATING THE BOILER

3.3 Boiler Location Considerations

- Ambient room temperature always above 32°F (0°C) to prevent the potential of freezing.
- Drainage of water (or water/ antifreeze solution) during boiler service or from safety relief valve discharge.
- Access to system water piping, gas supply, and electrical service.
- Boiler shall be installed on flat level surface which is capable of supporting the weight of the boiler, water, and equipment.
- Raise boiler above the floor on blocks if floor may get wet.
- Horizontal run to chimney shall be as short as possible.
- System piping exposed to freezing conditions: Use inhibited propylene glycol solutions certified by fluid manufacturer for use with closed water heating system. Do not use automotive or ethylene glycol.

Table 3-1: CONTAMINANTS

| Items to Avoid | Products Which May Contain These Items | Areas Where These Items May Be Found |
|-----------------------------------|---|---|
| Chlorine, Fluorine, and Compounds | Spray cans containing chlorofluorocarbons Chlorinated waxes/cleaners Chlorine-based swimming pool chemicals Calcium chloride used for thawing Sodium chloride used for water softening Swimming pool or spa chemicals De-icing salts or chemicals Carbon Tetrachloride | Swimming pools and pool storage areas Laundry room (Note 2) Confined storage areas |
| Airborne Particulates | Drywall dust Road or gravel dust Dryer lint Cat litter | Construction or remodelling areas (Note 1) Laundry room (Note 2) |
| Acids, Solvents, etc. | Paint, Varnish, Turpentine, etc. Cleaning Solvents Hydrochloric acid/muriatic acid Cements, adhesives and glues | Photo processing plants Garages with workshops Furniture refinishing areas and establishments |
| Laundry Chemicals | Laundry detergents, bleaches, fabric softeners, etc. Antistatic fabric softeners (dryer sheets) | Dry cleaning/laundry areas and establishments |
| Other | Permanent wave solutions Refrigerants (Freon, etc) (only where the refrigerant may be leaking from the appliance) | Beauty shops Refrigeration repair shops |
| Notes: | <p>1. It is recommended the boiler be isolated and not operated during construction/ renovation. Excessive particles ingested by the boiler may accumulate in the flueway passages possibly resulting in unsafe operation. In this case, unit servicing shall include cleaning of flueway passages and burner ports.</p> <p>2. If locating boiler in laundry room is unavoidable, it is manufacturer recommended the room be generously ventilated (well in excess of combustible air requirements), and homeowner seal laundry supply containers, and minimize room vapors.</p> <p>3. Piping allowing fresh air in should also be considered. See Section 5-1.</p> | |

⚠ WARNING

Burn and scald hazard. Safety relief valve could discharge steam or hot water during operation. Install discharge piping per these instructions.

⚠ WARNING

Burn and scald hazard. Safety relief valve shall be installed with spindle in **upright position only**, following ASME BPV code. Failure to follow these instructions could result in death or serious injury.

1. Refer to local codes and appropriate ASME Boiler and Pressure Vessel Code for additional installation requirements. Install safety relief valve using pipe fittings provided with boiler. See Figure 2.
2. Install safety relief valve with spindle in vertical position.
3. Do not install shutoff valve between boiler and safety relief valve.
4. Install discharge piping from safety relief valve. See Figure 2.
 - Use ¾" or larger pipe.
 - Use pipe suitable for temperatures of 375°F (191°C) or greater.
 - Individual boiler discharge piping shall be independent of other discharge piping.
 - Size and arrange discharge piping to avoid reducing safety relief valve relieving capacity below minimum relief valve capacity stated on rating plate.
 - Run pipe as short and straight as possible to location protecting user from scalding and properly drain piping.
 - Install union, if used, close to safety relief valve outlet.
 - Install elbow(s), if used, close to safety relief valve outlet and downstream of union (if used).
 - Terminate pipe with plain end (not threaded).
 - Terminate freely to atmosphere where discharge is clearly visible and no risk of freezing.

Figure 2 - Safety Relief Valve

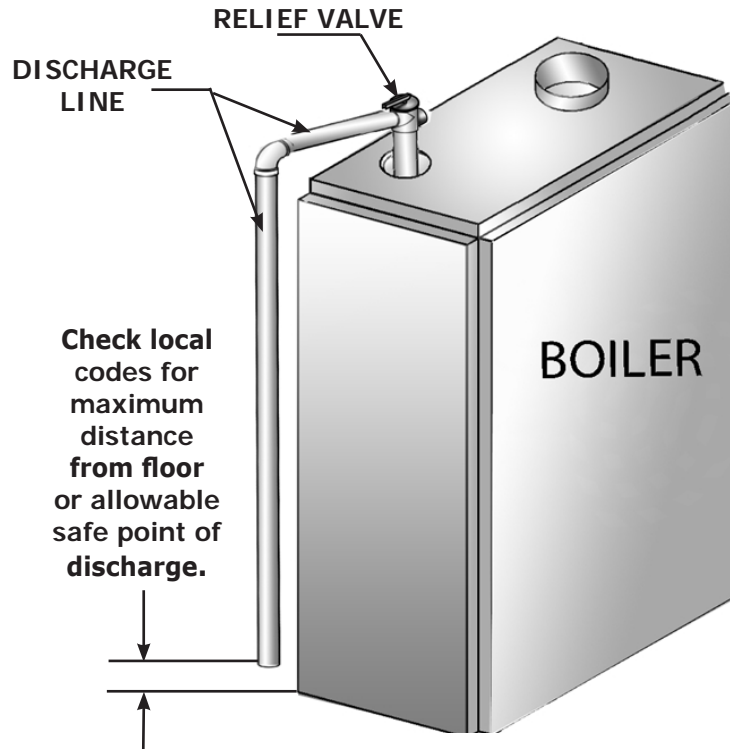

⚠ WARNING

- Poison hazard. Ethylene glycol is toxic. Do not use ethylene glycol.
- Never use automotive or standard glycol antifreeze, even ethylene glycol made for hydronic systems.
- Ethylene glycol can attack gaskets and seals used in hydronic systems.
- Do not use petroleum based cleaning or sealing compounds boiler system.
- Do not fill boiler or boiler system with softened water.
- Use only inhibited propylene glycol solutions certified by fluid manufacturer as acceptable for use with closed water heating system.
- Thoroughly clean and flush any system that used glycol before installing new Boiler.
- Provide user with Material Safety Data Sheet (MSDS) on fluid used.

NOTICE

If damage due to frozen pipes is a possibility, install appropriate safeguards and alarms on the heating system to prevent property damage due to frozen and burst pipes should the boiler heating system become inoperative due to a power outage, safety lockout or component failure.

4.3 Flush and Rinse System

Flush the entire system and rinse thoroughly to ensure no sludge will be introduced into the heating body of the boiler.

4.4 Water Treatment

Manufacturer recommends a water analysis be done on water used to fill the system. Treatment may be required based on the analysis results. For extremely hard water or pH below 7.0 consult your local water treatment company.

Manufacturer recommends a water analysis be done on water used to fill the system. Treatment may be required based on the analysis results.

For extremely hard water or pH below 7.0 consult your local water treatment company.

- If CH water is very hard or full of impurities, it must be adequately filtered and treated, otherwise damage and/or malfunction could be caused. Recommended water quality is:
 - o Hardness Less than 150 mg/L
 - o Acidity level 7-8 pH
 - o Sediments Particle size less than 50 micron
- If the water quality is outside these ranges, consult a local water treatment specialist for recommendations.
- If the water is treated, do not use petroleum based products or products containing mineral oil or hydrocarbons in order to avoid likely damage to parts made from rubber compounds (o-rings).

4 - CONNECTING SUPPLY AND RETURN PIPING

! WARNING

Burn and scald hazard. Safety relief valve could discharge steam or hot water during operation. Install discharge piping per these instructions. Failure to follow these instructions could result in death or serious injury.

1. Boiler is shipped assembled. Install discharge piping from safety relief valve. See Warning, Page 9.
2. Install temperature pressure gauge.
 - Apply pipe sealant to threads on shaft of gauge.
 - Thread gauge into supply water tee. See Figure 3.

NOTICE

Do not tighten gauge by hand. Gauge should be tightened using crescent wrench or 9/16" open end wrench. See Figure 3.

3. Connect supply and return lines to boiler. Connections may require additional fittings and parts, as shown on diagrams.

Figure 3 - Temperature Pressure Gauge

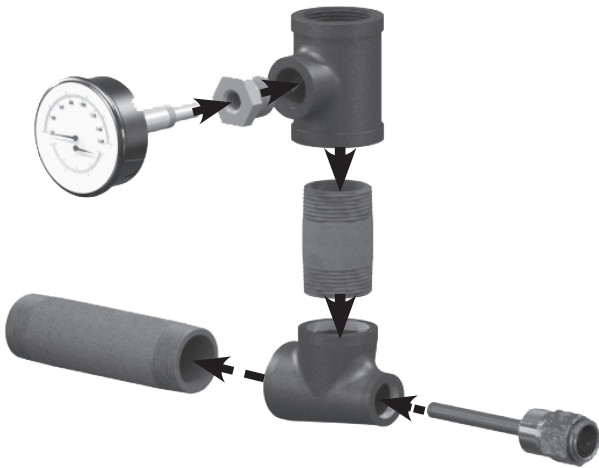

Verify clean water supply is available to water inlet valve. Install sand strainer when water supply is from a well or pump.

Install hot water boiler above radiation level or as required by Authority having jurisdiction.

Periodic inspection is necessary, as is flushing of float type devices, per manufacturers specific instruction.

Boiler is factory equipped with low water cutoff.

FOR USE WITH COOLING UNITS

- A. Boiler used in connection with refrigeration system, must be installed so that chilled medium is piped in parallel with heating boiler. Appropriate valves must be used to prevent chilled medium from entering heating boiler. See Figure 5 page 12.
- B. Boiler connected to heating coils located in air handling units where they may be exposed to refrigerated air circulation, piping system shall be equipped with flow control valves or other automatic means to prevent gravity circulation of boiler water during cooling cycle.

LOW WATER TEMPERATURE AND LARGE WATER CONTENT SYSTEM (See Figures 6 and 7, Page 13.)

Significant condensation may form in boiler and/or venting system if boiler is operated for long period of time with return temperatures of less than 120° F.

Condensate is corrosive and can cause severe damage to boiler and venting system. Minimum design return water temperature to prevent condensation in boiler and venting is 120°F. Minimum high limit setting is 140°F.

1. Boiler used in heating system where design water temperatures below 140°F are desired (e.g. radiant floor heating), 4-way mixing valve or suitable alternative is required to prevent low temperature return water from entering boiler. Follow mixing valve manufacturer's instructions.
2. Boiler connected to system having large water content (such as former gravity system), install system bypass. See Figures 6 and 7, page 13.
3. If boiler water reset control is used to operate boiler, minimum reset supply water temperature setpoint must be at least 140°F, unless mixing valve is used as in (1) above.

Figure 4 - Typical Hot Water Piping

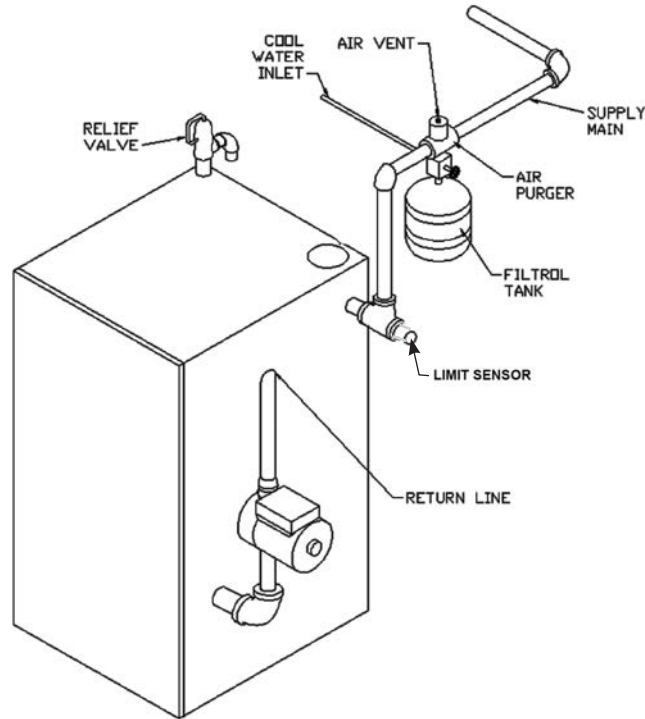
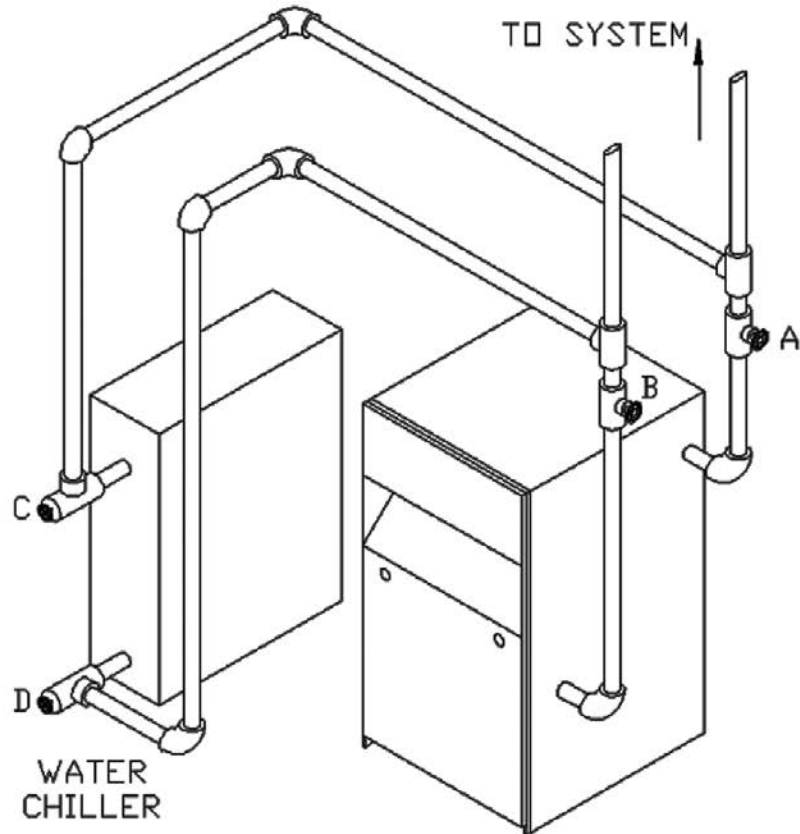

Figure 5 - Chilled Water Piping

VALVES A & B
OPEN FOR HEATING;
CLOSE FOR COOLING

VALVES C & D
CLOSE FOR HEATING;
OPEN FOR COOLING



Bypass Piping Required For High Mass (Large Water Content) Systems

Figure 6 - BYPASS PIPING - CIRCULATOR ON SUPPLY

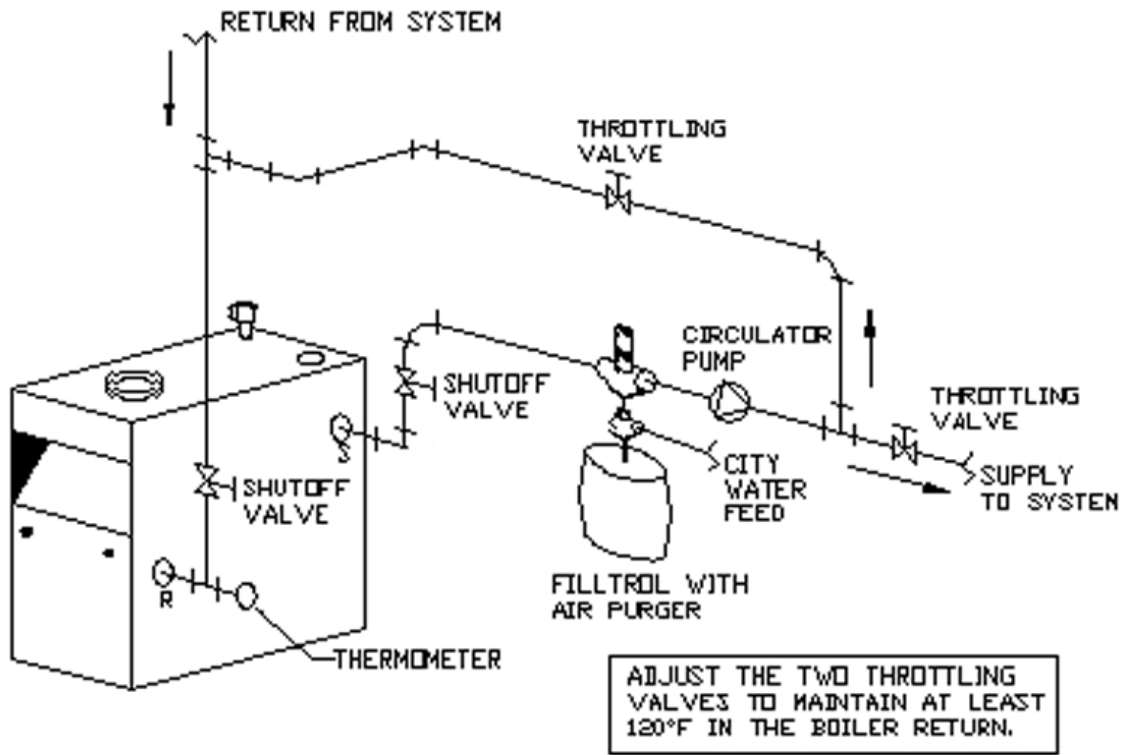
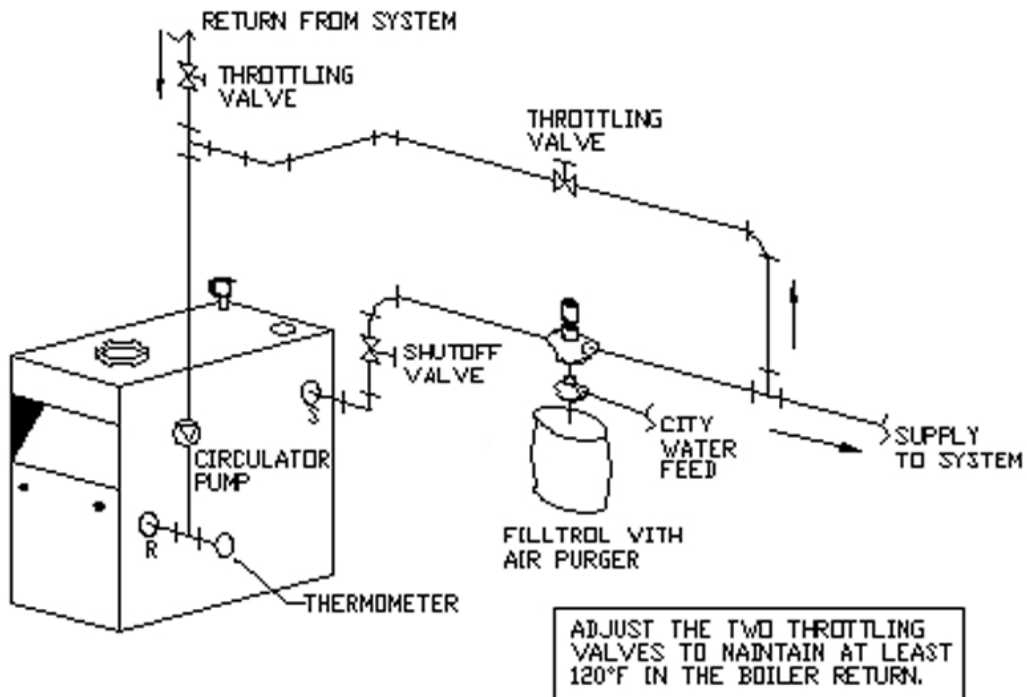

Figure 7 - BYPASS PIPING - CIRCULATOR ON RETURN



5 - VENTILATION & COMBUSTION AIR

Provide combustion air and ventilation air in accordance with the section "Air for Combustion and Ventilation," of the National Fuel Gas Code, ANSI Z223.1/NFPA 54, or Sections 8.2, 8.3 or 8.4 of Natural Gas and Propane Installation Code, CAN/CSA B149.1, or applicable provisions of local building codes.

Provide make-up air where exhaust fans, clothes dryers, and kitchen ventilation equipment interfere with proper operation.

National Fuel Gas Code recognizes several methods of obtaining adequate ventilation and combustion air. Requirements of the authority having jurisdiction may override these methods.

- Engineered Installations. Must be approved by authority having jurisdiction.
- Mechanical Air Supply. Provide minimum of 0.35 cfm per Mbh for all appliances located within space. Additional requirements where exhaust fans installed. Interlock each appliance to mechanical air supply system to prevent main burner operation when mechanical air supply system not operating.
- All Indoor Air. Calculate minimum allowable room volume for all appliances in space. Use a different method if minimum volume not available.
 - A. Standard Method. Cannot be used if known air infiltration rate is less than 0.40 air changes per hour. See Table 4 for space with boiler only. Use equation for multiple appliances.

$$\text{Volume} \geq 50 \text{ ft}^3 \times \text{Total Input [Mbh]}$$
 - B. Known Air Infiltration Rate. See Table 4 for space with boiler only. Use equation for multiple appliances. Do not use an air infiltration rate (ACH) greater than 0.60.

$$\text{Volume} \geq 21 \text{ ft}^3/\text{ACH} \times \text{Total Input [Mbh]}$$
 - C. Refer to National Fuel Gas Code for opening requirements between connected indoor spaces.

- All Outdoor Air. Provide permanent opening(s) communicating directly or by ducts with outdoors.
 - A. Two Permanent Opening Method. Provide opening commencing within 12 inches of top and second opening commencing within 12 inches of bottom of enclosure.
 - Direct communication with outdoors or communicating through vertical ducts. Provide minimum free area of 1 in² per 4 Mbh of total input rating of all appliances in enclosure.
 - Communicating through horizontal ducts. Provide minimum free area of 1 in² per 2 Mbh of total input rating of all appliances in enclosure.
 - B. One Permanent Opening Method. Provide opening commencing within 12 inches of top of enclosure. Provide minimum clearance of 1 inch on sides/back and 6 inches on front of boiler (does not supersede clearance to combustible materials).
- Refer to National Fuel Gas Code for additional requirements for louvers, grilles, screens and air ducts.
- Combination Indoor and Outdoor Air. Refer to National Fuel Gas Code for application information.

Table 3 - Minimum Room Volume, Indoor Air Only*

| Input Mbh | Standard Method | Known Air Infiltration Rate Method ACH (Air Changes Per Hour) | | | | | |
|-----------|-----------------|---|-------|-------|-------|-------|-------|
| | | 0.1 | 0.2 | 0.3 | 0.4 | 0.5 | 0.6 |
| 75 | 3750 | 15750 | 7875 | 5250 | 3938 | 3150 | 2625 |
| 112.5 | 5625 | 23625 | 11813 | 7875 | 5906 | 4725 | 3938 |
| 150 | 7500 | 31500 | 15750 | 10500 | 7875 | 6300 | 5250 |
| 187.5 | 9375 | 39375 | 19688 | 13090 | 9844 | 7875 | 6563 |
| 255 | 11250 | 47250 | 23625 | 15750 | 11813 | 9450 | 7875 |
| 262.5 | 13125 | 55125 | 27563 | 18375 | 13781 | 11025 | 9188 |
| 299 | 14950 | 62790 | 31395 | 20930 | 15698 | 12558 | 10465 |

* Table values based on boiler only. Add volume for any additional appliances.

⚠ WARNING

Boiler and venting installations shall be performed by a qualified expert and in accordance with the appropriate manual. Installing or venting boiler or other gas appliance with improper methods or materials may result in serious injury or death due to fire or to asphyxiation from poisonous gases such as carbon monoxide which is odorless and invisible.

Boilers connecting to gas vents or chimneys, vent installations shall be in accordance with "Venting of Equipment", of the National Fuel Gas Code, ANSI Z223.1/NFPA 54 or "Venting Systems and Air Supply for Appliances," of the Natural Gas and Propane Installation Code, CAN/CSA B149.1, or applicable provisions of the local building codes.

Check Your Chimney

It must be clean, right size, properly constructed and in good condition.

Chimney Sizing

Chimney sizing, and vent installation must be in accordance with The National Fuel Gas Code, ANSI Z223.1/NFPA 54 or CAN/CSA B149.1, or applicable provisions of local building codes.

This is a high efficiency boiler with low stack temperature. Following recommendations are in addition to requirements of the National Fuel Gas Code.

1. Type B double wall vent pipe is recommended for vent connector. Single wall vent connectors should not be used unless following conditions are true:
 - a) Except for basement, boiler is not installed in unheated space.
 - b) Total horizontal portion of vent connector, not including elbows is less than 5 feet in length.
2. Outside chimneys (i.e. chimneys exposed to outdoors below roof line) should not be used unless they are:
 - a) enclosed in a chase, or
 - b) lined with type B vent pipe, or listed flexible vent liner, or other certified chimney lining system.
3. Where possible it is recommended to common vent boiler and water heater.
4. For multiple boiler installations, consult boiler manufacturer for venting recommendations.

Requirements

1. Vent pipe must slope upward from the boiler not less than 1/4 inch for every 1 foot (21 mm/m) to vertical vent terminal.
2. Horizontal portions of venting system shall be supported rigidly every 5 feet and at the elbows. No portion of vent pipe should have any dips or sags.

3. Boiler series is classified as a Category I. Vent installation shall be in accordance with "Venting of Equipment," of the *National Fuel Gas Code*, ANSI Z223.1/NFPA 54, or "Venting Systems and Air Supply for Appliances," of the *Natural Fuel Gas and Propane Installation Code*, CAN/CSA B149.1, or applicable provisions of the local building codes.
4. Inspect chimney. Chimney shall be lined. Verify chimney is constructed according to NFPA 211 and NFPA 54. Vent or vent connector shall be Type B or metal pipe having resistance to heat and corrosion not less than that of galvanized sheet steel or aluminum not less than 26 gauge thick, 24 gauge for 6 and 7 inch.
5. Connect flue pipe from draft hood to chimney. Bolt or screw joints together to avoid sags. Flue pipe should not extend beyond inside wall of chimney more than 1/4 inch. Do not install manual damper in flue pipe or reduce size of flue outlet except as provided by the latest revision of *National Fuel Gas Code*, ANSI ANSI Z223.1/NFPA 54 or CAN/CSA B149.1. Protect combustible ceiling and walls near flue pipe as required by National Fuel Gas Code. Where two or more appliances vent into a common flue, the area of the common flue must be at least equal to the area of the largest flue plus 50 percent of the area of each additional flue.

Chimney Inspection

Chimney must be clean, right size, properly constructed and in good condition.

Installation must conform to requirements of the authority having jurisdiction or, in absence of such requirements, to The *National Fuel Gas Code*, ANSI Z223.1/NFPA 54.

Vent Pipe

- Fasten sections of vent pipe with 3 sheet metal screws at each joint to make piping rigid.
- Support horizontal portions of vent system to prevent sagging.
- Use stove pipe wires or metal strapping every 5' to support pipe from above.
- Vent pipe through crawl space, use double wall vent pipe.
- Vent pipe passing through combustible wall or partition, use ventilated metal thimble. Thimble should be 4" larger in diameter than vent pipe.

NOTICE

Minimum Vent Pipe Clearance - Wood and other combustible materials must not be closer than 6" from any surface of single wall metal vent pipe. Listed Type B vent pipe or other listed venting systems shall be installed in accordance with their listing.

WARNING

Do not connect boiler to any portion of mechanical draft system operating under positive pressure.

Removing Existing Boiler From Common Venting System

When an existing boiler is removed from common venting system, common venting system is likely to be too large for proper venting of appliances remaining connected to it. At time of removal of existing boiler, following steps shall be followed with each appliance remaining connected to the common venting system placed in operation, while other appliances remaining connected to common venting system are not in operation.

1. Seal any unused openings in the common venting system.
2. Visually inspect the venting system for proper size and horizontal pitch and determine there is no blockage or restriction, leakage, corrosion and other deficiencies which could cause an unsafe condition.
3. Insofar as is practical, close all building doors and windows and all doors between the space in which the appliances remaining connected to the common venting system are located and other spaces of the building. Turn on clothes dryers and any appliance not connected to the common venting system. Turn on any exhaust fans, such as range hoods and bathroom exhausts, so they will operate at maximum speed. Do not operate a summer exhaust fan. Close fireplace dampers.
4. Place in operation the appliance being inspected. Follow the lighting instructions. Adjust thermostat so appliance will operate continuously.
5. Test for spillage at the draft hood relief opening after 5 minutes of main burner operation. Use the flame of a match or candle, or smoke from a cigarette, cigar or pipe.
6. After it has been determined that each appliance remaining connected to the common venting system properly vents when tested as outlined above, return doors, windows, exhaust fans, fireplace dampers and any other gas-burning appliance to their previous conditions of use.
7. Any improper operation of the common venting system should be corrected so the installation conforms with the National Fuel gas Code, ANSI Z223.1/NFPA 54, and/or the Natural Gas and Propane Installation Code, CAN/CSA B149.1. When re-sizing any portion of the common venting system, the common venting system should be re-sized to approach the minimum size determined using the appropriate tables in Chapter 13 of the National Fuel Gas Code, ANSI Z223.1/NFPA 54, and/or the Natural Gas and Propane Installation Code, CAN/CSA B149.1.

Connecting The Vent Damper And Vent Connector

Refer to Figure 1, page 4 for size and location of vent (flue opening).

NOTICE

Damper blade on furnished vent damper has 1/2 square inch hole (approximately 3/4" diameter). Boilers equipped with intermittent ignition, hole should be plugged by using plug supplied with vent damper.

1. Position furnished vent damper on top of flue outlet collar. Fasten damper securely to flue outlet collar with sheet metal screws. Verify damper blade has clearance to operate inside of diverter. Do not modify either draft diverter or vent damper during installation.

As An Option

Damper may be installed in horizontal or vertical position, closer to flue outlet collar preferred. See Figures 8, 9 and 10 and enclosed vent damper instructions.

2. Install vent damper to service only single boiler for which it is intended. Damper position indicator shall be in visible location following installation. Locate damper so it is accessible for servicing. See Figure 9.
3. Damper must be in the open position when appliance main burners are operating.
4. Boiler is equipped with factory wired harness that plugs into vent damper.
5. Slope pipe up from boiler to chimney not less than 1/4" per foot.
6. Run pipe as directly as possible with as few elbows as possible.
7. Do not connect to fireplace flue.
8. End of vent pipe must be flush with inside face of chimney flue. Use a sealed-in thimble for chimney connection.

Fasten sections of vent pipe with sheet metal screws to make piping rigid. Support horizontal portions of vent system to prevent sagging. Use stovepipe wires every 5' to support pipe from above. Use double wall vent pipe if vent pipe must go through crawl space. Where vent pipe passes through combustible wall or partition, use ventilated metal thimble. Thimble should be 4 inches larger in diameter than vent pipe.

Figure 8 - Vent Damper Installation

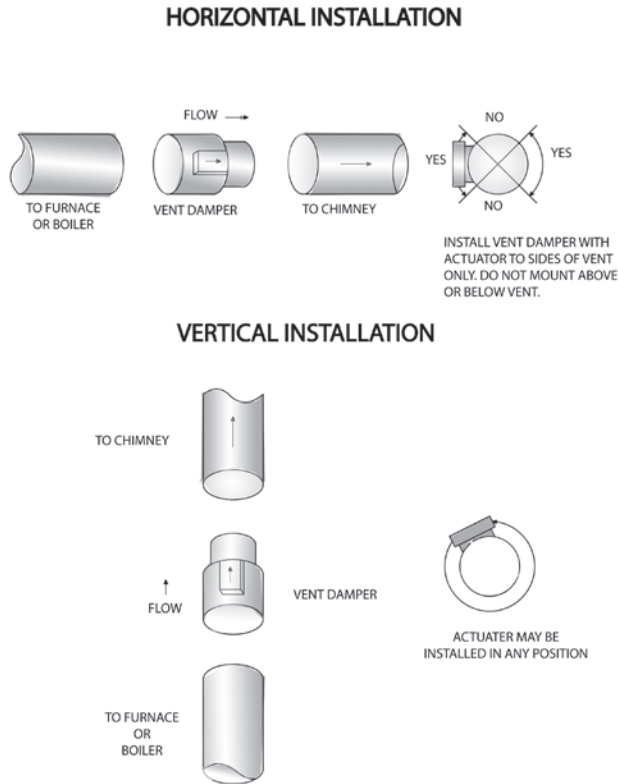
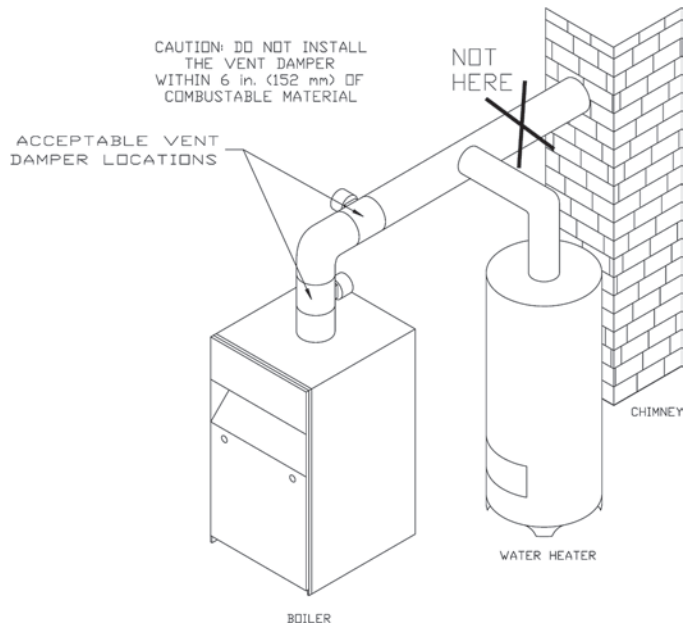

Figure 9 - Vent Damper Placement



Annually check vent damper and all flue product carrying areas of appliance, with particular attention given to deterioration from corrosion or other sources. If you see corrosion or other deterioration, contact your heating contractor for repairs. Check vent damper operation as follows:

- When boiler is off, check vent damper positions indicator points to closed position, Figure 10.
- Turn thermostat or controller up to call for heat and check vent damper indicator points to open position.
- Turn thermostat or controller down again and check damper position indicator returns to closed position.

Vent Damper Manual Operation

Vent damper may be placed in open position to permit burner operation by using "HOLD DAMPER OPEN" switch, located on damper controller. Thermostat will control burner firing as before, while damper will remain open. **DO NOT** turn damper open manually or motor damage will result. Set switch to "AUTOMATIC OPERATION" to close vent damper during burner off cycle.

For further information, and vent damper troubleshooting guide, refer to manual packaged with vent damper and Appendix A of this manual.

Inspect vent damper at least once a year by a qualified service technician.

Figure 10 - Vent Damper Position Indicator

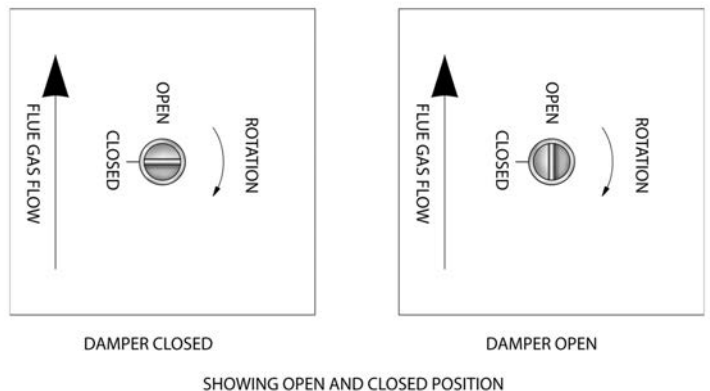

CAUTION

WHAT TO DO IF YOU SMELL GAS

- Do not try to light any appliance.
- Do not touch any electrical switch; do not use any phone in your building.
- Immediately call your gas supplier from a neighbor's phone. Follow gas supplier's instructions.
- If you cannot reach your gas supplier, call the fire department.

CHECK GAS SUPPLY

Gas pipe to your boiler must be correct size for length of run and for total BTU per hour input of all gas utilization equipment connected to it. See Table 5 for proper size. Be sure your gas line complies with local codes and gas company requirements.

CONNECTING THE GAS PIPING See Figure 11.

Gas line enters boiler from right side.

- Use piping materials and joining methods acceptable to authority having jurisdiction. In absence of such requirements:
 - USA - National Fuel gas Code, ANSI Z223.1/NFPA 54
 - Canada - Natural Gas and Propane Installation Code, CAN/CSA B149.1
- Use pipe joint compound suitable for LP gas on male threads only.
- Use ground joint unions.
- Install sediment trap upstream of gas controls.
- Use two pipe wrenches when making connection to gas valve to keep it from turning.
- Install manual shut-off valve in vertical pipe about 5 feet above floor.
- Tighten all joints securely.
- Propane gas connections should only be made by licensed propane installer.
- Two-stage regulation should be used by propane installer.
- Propane gas piping should be checked out by propane installer.

CHECKING GAS PIPING

DANGER

Fire Hazard. Do not use matches, candles, open flames, or other methods providing ignition source. Failure to comply will result in death or serious injury.

Pressure test boiler and gas connection before placing boiler in operation.

- Pressure test over 1/2 psig (3.5 kPa). Disconnect boiler and its individual gas shutoff valve from gas supply system.
- Pressure test at 1/2 psig (3.5 kPa) or less. Isolate boiler from gas supply system by closing manual gas shutoff valve.
- Locate leakage using gas detector, noncorrosive detection fluid, or other leak detection method acceptable to authority having jurisdiction. Do not use matches, candles, open flames, or other methods providing ignition source.
- Correct leaks immediately and retest.

Table 5 - Gas Pipe Sizes

| NATURAL GAS | | | | |
|---------------------|--|---------|-----------|---------|
| | Pipe Capacity - BTU Per Hour Input Includes Fittings | | | |
| Length of Pipe - FT | 1/2" | 3/4" | 1" | 1 1/4" |
| 20 | 92,000 | 190,000 | 350,000 | 625,000 |
| 40 | 63,000 | 130,000 | 245,000 | 445,000 |
| 60 | 50,000 | 105,000 | 195,000 | 365,000 |
| PROPANE GAS | | | | |
| | Pipe Capacity - BTU Per Hour Input Includes Fittings | | | |
| Length of Pipe - FT | Copper Tubing * | | Iron Pipe | |
| | 5/8" | 3/4" | 1/2" | 3/4" |
| 20 | 131,000 | 216,000 | 189,000 | 393,000 |
| 40 | 90,000 | 145,000 | 129,000 | 267,000 |
| 60 | 72,000 | 121,000 | 103,000 | 217,000 |

* Outside diameter
Measure length of pipe or tubing from gas meter or propane second stage regulator.

Figure 11 - Gas Piping

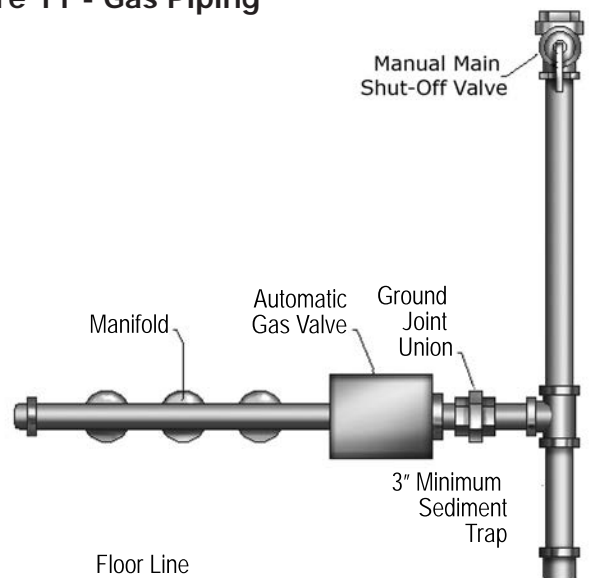

9 - ELECTRICAL WIRING

WARNING

Electrical shock hazard. Turn OFF electrical power supply at service panel before making electrical connections. Failure to do so could result in death or serious injury.

NOTICE

Label all wires prior to disconnection when servicing controls. Wiring errors can cause improper and dangerous operation. Verify proper operation after servicing.

molex plug, that plugs into 4 pin molex receptacle inside vent damper operator.

Vent damper must be connected for boiler to operate.

If any of the original wire as supplied with this appliance must be replaced,

It must be replaced with type 105°C thermoplastic wire or its equivalent.

Electrically bond boiler to ground in accordance with requirements of authority having jurisdiction. Refer to:

- USA- National Electrical Code, ANSI/NFPA 70.

ELECTRIC POWER SUPPLY

Run separate 120 volt circuit from separate over current protective device in electrical service entrance panel. This should be a 15 ampere circuit. Locate shut-off switch at boiler. It must be turned off during any maintenance. Connect 120 volt power supply to control leads L1 (HOT) and L2.

Boiler is factory equipped with a low water cutoff.

Run a 14 gauge or heavier copper wire from boiler to grounded connection in service panel or properly driven and electrically grounded ground rod.

THERMOSTAT INSTALLATION

1. Thermostat should be installed on an inside wall about four feet above the floor.
2. NEVER install thermostat on outside wall.
3. Do not install a thermostat where it will be affected by drafts, hot or cold pipes, sunlight, lighting fixtures, televisions, a fireplace, or a chimney.
4. Check thermostat operation by raising and lowering thermostat setting as required to start and stop the burners.
5. Instructions for the final adjustment of the thermostat are packaged with the thermostat (adjusting heating anticipator, calibration, etc.)

Set heat anticipator at .2 amps. 24 volt thermostat connects to aquastat terminals T and TV.

VENT DAMPER WIRING

Boiler is equipped with factory wired harness with 4 pin

Figure 12 - Integrated High Limit Electronic Ignition Control

⚠ WARNING
 Modification, substitution or elimination of factory equipped, supplied or specified components may result in personal injury or loss of life.

WIRING DIAGRAM

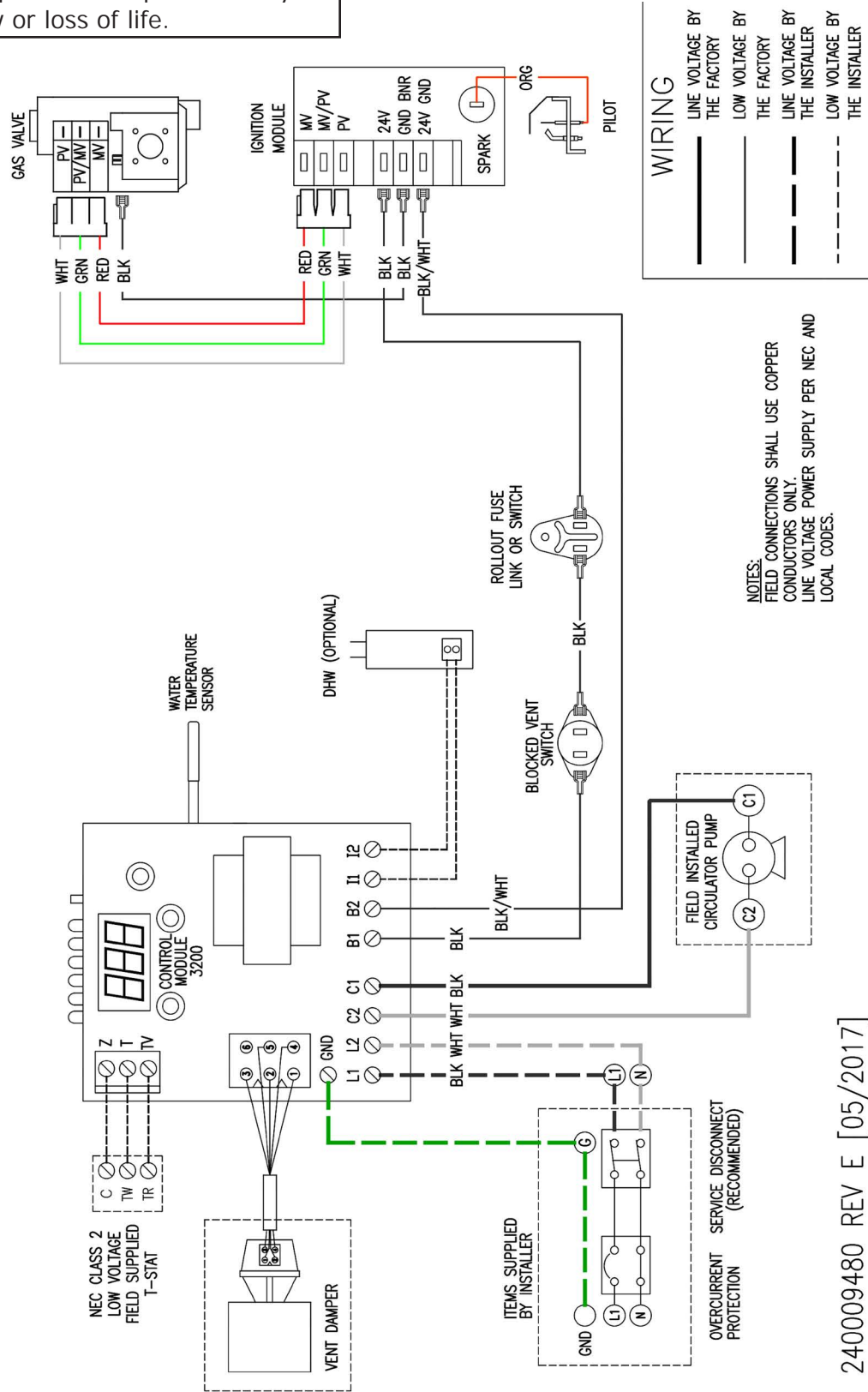

240009480 REV E [05/2017]

WARNING

Adding water to hot boiler may result in heat exchanger failure. Before filling boiler verify heat exchanger is not hot. Failure to follow these instructions could result in death or serious injury.

FILLING SYSTEM WITH WATER

- Close air vents on all radiation units. Open valves to these units.
- Verify boiler and expansion tank drain valves are closed.
- Air bleed screw on tank drain fitting should be closed.
- Open valve in line from boiler to expansion tank. Open water inlet to your boiler and leave it open. Start with lowest radiation unit. Open air vent on this unit. When all air has escaped and water starts to flow from vent, close it.
- Go to next radiation unit, and repeat this process. Repeat until you have covered every radiation units in the system (ending up at highest unit in system).
- If your units have automatic vents, manual venting is unnecessary but it will speed up the proper filling of your system.
- If your system is closed expansion tank system, you may leave it open to refill system automatically as needed.
- Check temperature pressure gauge. Note position of hand indicating pressure. This should be between 10 and 15 psi. Any lowering of this movable hand below 10 psi. Will indicate loss of water due to leakage. Automatic fill valve should compensate for this. Instructions are packaged with the valve.

⚠ WARNING

If you do not follow these instructions exactly, a fire or explosion may result causing property damage, personal injury or loss of life.

- This appliance is equipped with an ignition device which automatically lights burner. **Do NOT try to light this burner by hand.**
- Before operating smell all around appliance area for gas. Be sure to smell next to floor because some gas is heavier than air and will settle to the floor.
- **Use only your hand to turn the gas shutoff valve.** Never use tools. If valve will not turn by hand, do not try to repair it, call a qualified service technician. Force or attempted repair may result in fire or explosion.
- **Do not use this appliance if any part has been under water.** Immediately call a qualified service technician to inspect appliance and to replace any part of control system and any gas control which has been under water.

LIGHTING PROCEDURE FOR BOILER WITH INTERMITTENT PILOT SYSTEM

For Your Safety, Read Before Operating!!

- A. This appliance is equipped with an ignition device which automatically lights the pilot. Do not try to light appliance by hand.

⚠ CAUTION

WHAT TO DO IF YOU SMELL GAS

- Do not try to light any appliance.
- Do not touch any electrical switches; do not use any phone in your building.
- Immediately call your gas supplier from a neighbor's phone. Follow the gas supplier's instructions.
- If you cannot reach your gas supplier, call the fire department.

1. STOP! Read the safety information above.
2. Set the thermostat to lowest setting.
3. Turn off all electric power to the appliance.
4. This appliance is equipped with an ignition device which automatically lights the pilot. Do **not** try to light the pilot by hand.



5. Remove lower front panel.
6. Rotate the gas control knob clockwise  to "OFF".

Figure 13 - Automatic Gas Valve

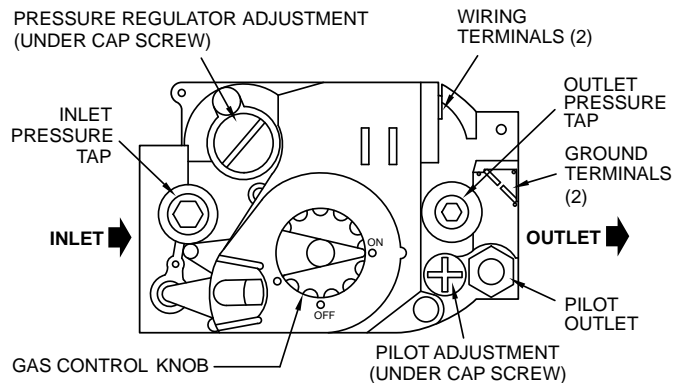

7. Wait five (5) minutes to clear out any gas. Then smell for gas, including near the floor. If you smell gas, STOP! Immediately call your gas supplier from a neighbor's phone. Follow the gas supplier's instructions. If you don't smell gas, go to next step.
8. Rotate gas control knob counterclockwise  to "ON".
9. Replace lower front panel.
10. Turn on all electric power to the appliance.
11. Set thermostat to desired setting.
12. If the appliance will not operate, follow the instructions "To Turn Off Gas To Appliance" and call your service technician or gas supplier.

TO TURN OFF GAS TO APPLIANCE

1. Set the thermostat to lowest setting.
2. Turn off all electric power to the appliance if service is to be performed.
3. Push in gas control knob slightly and turn clockwise  to "OFF" Do not force.

AUTOMATIC GAS VALVE

Automatic Gas Valve opens or closes according to heat requirements of thermostat and temperature limit control. It closes if pilot goes out. Each individual control must be operating correctly before any gas can pass to burners. Any one control can hold gas supply from burner regardless of demand of any other control.

SAFETY PILOT

Safety Pilot prevents flow of gas to burner if pilot goes out, or will not ignite.

GAS VALVE SAFETY SHUTDOWN TEST

Ignition system safety shutoff device must be tested after placing boiler in operation.

RELIGHT

Electric and gas shall be off for 5 minutes before relighting.

THERMOSTAT

Keep it set at desired room temperature. If windows are to be opened or heat is not needed, move thermostat pointer to lower setting.

NOTICE

In event of failure of any component, system will not operate or will go into safety lockout. System is completely self-checking. On every call for heat, each component must be functioning properly to permit operation. Safety lockout system has to be reset by turning thermostat to lowest setting for one minute, then back to normal setting.

ADJUST PILOT BURNER

Pilot flame should surround 3/8" to 1/2" of the pilot sensor. See Figure 14. If flame needs adjusting, do it as follows:

1. Remove screw cover over pilot adjusting screw.
2. Insert small screwdriver and adjust flame as needed. Turn screw counterclockwise to increase flame, clockwise to decrease.
3. Replace screw cover over pilot adjusting screw.

Figure 14 - Pilot Flame

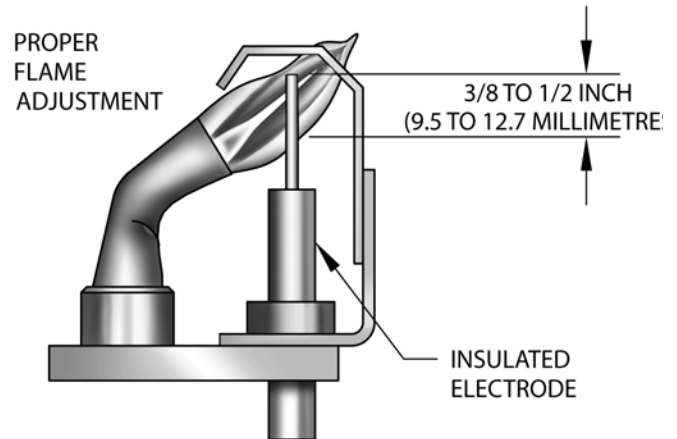

MAIN BURNER(S)

- Main burners do not require primary air adjustment and are not equipped with primary air shutters.
- Main burner flames form sharp blue inner cones in softer blue outer mantel, with no yellow.
- Puffs of air from blowing on flame or stamping on floor will cause flames to turn orange momentarily. This is not unusual. Remain still when observing main burner flames.
- If flame appearance is not correct, check main burner orifices, burner throat and flame ports for dust and lint obstruction. It may be necessary to remove rollout shield to observe main burner flames. Replace rollout shield after observation. Refer to Figure 15.

Figure 15 - Burner

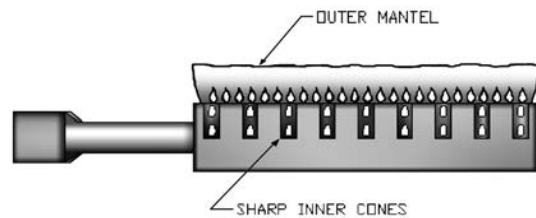

ADJUST LIMIT CONTROLS

Instructions for each control are included with controls. Settings can be changed. Refer to Appendix A page 29 for information.

CHECK THERMOSTAT OPERATION

- A. When set above temperature indicated on thermostat, boiler should ignite.
- B. Verify thermostat turns boiler off when room temperature reaches selected setting and starts boiler operating when room temperature falls a few degrees.
- C. After setting limit control to limit setting, check to see if it shuts off gas supply to burners. Turn your thermostat up to call for heat and let boiler run until temperature of water reaches limit setting. Gas valve should shut off and circulator running until thermostat is satisfied, or water cools enough to restart burners through limit control.
- D. Set thermostat for desired temperature. Conditions in your home and location of thermostat will govern this setting.

1 HI TEMP illuminates when boiler water temperature reaches high limit setting. Remains lit until water temperature falls 10°. Prevents burner operation while this LED is on.

2 LWCO Active Indicates low water cut-off (LWCO) function of limit control is active. When control is installed with a well, LED is on at all times when control is powered. Important: If control is installed with a well other than Electro-Well, LED will not illuminate indicating control is not providing low water cut-off functionality.

WARNING

Burn and scald hazard. Do not add water until boiler has fully cooled. Failure to follow these instructions could result in death or serious injury.

3 LWCO Low Water illuminates if boiler is in low water condition. Limit control prevents burner operation during this condition.

Important: Have system checked by qualified service agency prior to resuming operation.

4 ECONOMY Active Indicates thermal targeting function is active and limit control is reducing boiler temperature to conserve fuel. Economy feature is activated using Economy dial.

5 ECONOMY TARGET Economy feature is active, limit control continually sets target temperatures below high limit setting to maximize fuel efficiency. When boiler water reaches target temperature, LED illuminates and burner shuts down. Boiler water will continue to circulate and heat the house as long as thermostat call continues. LED will stay lit until boiler temperature drops below differential set point at which point boiler will be allowed to fire again.

Note: LED illuminates regularly during normal boiler operation.

6 LWCO TEST Button

To Test Low Water Cut-Off: Press and hold Test/Settings button for 5 seconds. Display will read LWCO.

LWCO TEST **LCO**

Red Low Water light will illuminate and burner circuit (B1 and B2) will de-energize.

Note: Control must be installed with Electro-Well for low water cut-off functionality.

Table 6 - Troubleshooting

| | |
|---------------------------------------|--|
| Burner Will Not Fire | |
| No or Insufficient Domestic Hot Water | If installed with indirect water heater, insure switch controlling indirect water heater is properly connected to I1-I2 (see wiring diagram). This insures domestic water calls are prioritized. If I1-I2 is not used, turn Economy Feature OFF. |
| House will not get or stay warm | <ol style="list-style-type: none"> 1. Check for air bound radiators. 2. Check thermostat settings including heat anticipator settings (common on non-digital thermostats). 3. Check Economy settings. Economy feature, much like outdoor reset controls, lowers average boiler temperature, can slow or prevent the house from coming up to temperature. Move to lower setting. |

! CAUTION

WHAT TO DO IF YOU SMELL GAS

- Do not try to light any appliance.
- Do not touch any electrical switch; do not use any phone in your building.
- Immediately call your gas supplier from a neighbor's phone. Follow the gas supplier's instructions.
- If you cannot reach your gas supplier, call the fire department.

IF YOUR SYSTEM IS NOT HEATING OR NOT GIVING ENOUGH HEAT . . .

You may avoid inconvenience and service calls by checking these points before you call for service.

| Possible Cause | What to do |
|----------------------------------|---|
| Thermostat is not set correctly | Reset thermostat above room temperature |
| Burner is not operating properly | Check flame. If it is yellow, burner is not getting enough air. Or, if flame is blue and noisy and seems to lift off burner, burner is getting too much air. Contact your service technician. |
| No electric power to boiler | Check over current protection. Verify electric power supply circuit is "ON". |
| Controls out of adjustment | Reset according to instructions. |
| Radiators not heating | Open radiator vents to expel air. Check flow control valve (if used). It may be in closed position. |
| Circulating pump not running | Check over current protection. Check relay operation. |
| Poor electrical contact | Check all control terminals and wire joints. |
| Rollout switch blown | Have your service agent check heat exchanger for blockage. Replace rollout switch with exact replacement. |
| Blocked vent blown | Have your service agent check venting system and chimney for blockage, or down draft condition. Reset blocked vent. |
| Vent damper not operating | Consult troubleshooting guide |

IF BURNER IS NOISY . . .

| Possible Cause | What to do |
|-------------------------------|-----------------------------|
| Gas input amount is incorrect | Contact your service agent. |

RELIEF VALVE LEAKING . . .

| Possible Cause | What to do |
|-----------------------------|---|
| Dirt on seat | Open valve manually. Allow water to run and clear valve seat. |
| Water logged expansion tank | Drain tank, see instructions. |

HAVE YOUR SERVICE AGENT CHECK ANY PROBLEM YOU ARE UNABLE TO CORRECT.

BURNERS

Beginning of heating season visually check pilot and main burner flames. See Page 23.

SAFETY RELIEF VALVE

Refer to page 7 for important information. To test safety relief valve refer to valve manufacturer's instructions packaged with relief valve. Call Technical Support if manufacturer's instruction are not located.

EXPANSION TANK

Tank may become waterlogged, or may receive excess of air. Frequent automatic opening of safety relief valve indicates water logging. High boiler temperature accompanied by unusually low radiation unit temperature (and "knocking") indicates excess air in tank.

To correct:

1. Close valve between boiler and tank. Drain tank until empty.
2. Check all tank plugs and fittings. Tighten as necessary.
3. Open valve between boiler and tank. Water will rise to normal height in tank if you have automatic fill valve (otherwise, manually refill system).

BOILER FLUE PASSAGES

Recommend following checked annually by qualified service agent.

- flue passages
- burner adjustment
- operation of controls

Before start of each season (or whenever system has been shut down for some time) recheck whole system for leaks and recheck boiler and vent pipe for leaks. Replace or patch any boiler seals that are faulty.

VENT PIPE

Venting and piping should be checked at least once a season. If vent piping shows any sign of leaking, replace immediately.

WATER SYSTEM

If system is to remain out of service during freezing weather, always **drain it** completely (water left in to freeze will crack pipes and/or boiler).

CLEANING YOUR BOILER AND BURNERS

Flue passages between sections should be examined yearly and cleaned if necessary.

To clean:

- Remove burners, pilot, and vent pipe.
- Remove top and front jacket panels.
- Remove two screws attaching intermediate front panel to left and right side jacket panels.
- Remove draft diverter and intermediate front panel together.
- Carefully remove cerafelt gasket strips.
- Clean passageways between sections with flexible handle wire brush. Remove dirt from bottom of boiler and from between sections by vacuuming.
- Verify all flame ports in burners are open and clear. Shake out or blow out all loose dirt in burners.
- Reseal seams between adjacent sections as necessary with 400° F RTV silicone sealant.
- Reassemble all parts.
- Verify tightness of pilot connections and condition of burner flames after reassembly. See Figures 15 and 16, pages 20.
- Verify vent pipe connections to chimney are secure and no obstructions are present.

HOUSEKEEPING

- Keep boiler area clear and free from combustible materials, gasoline and other flammable vapors and liquids.
- Keep boiler area clear of debris and other materials obstructing flow of combustion and ventilation air.



Table 1 - Ratings and Capacities

| BOILER MODEL NUMBER ⁽¹⁾ | † NATURAL GAS | | | † PROPANE GAS | | | AFUE |
|------------------------------------|--------------------------|-------------------------------------|---|--------------------------|-------------------------------------|--|--|
| | Input ⁽³⁾ Mbh | Heating Capacity ⁽³⁾ Mbh | (2) NET AHRI RATING Water, ⁽³⁾ Mbh | INPUT ⁽³⁾ Mbh | HEATING CAPACITY ⁽³⁾ MBH | (2) NET AHRI RATING ⁽³⁾ Mbh | INTERMITTENT IGNITION WITH VENT DAMPER |
| WPSB-3 | 75 | 63 | 55 | 70 | 59 | 51 | 84.0 |
| WPSB-4 | 112.5 | 94 | 82 | 105 | 88 | 77 | 84.0 |
| WPSB-5 | 150 | 126 | 110 | 140 | 118 | 103 | 84.1 |
| WPSB-6 | 187.5 | 157 | 137 | 175 | 147 | 128 | 84.1 |
| WPSB-7 | 225 | 188 | 163 | 210 | 176 | 153 | 84.0 |
| WPSB-8 | 262 | 221 | 191 | 245 | 208 | 179 | 84.0 |
| WPSB-9 | 299 | 252 | 218 | 280 | 237 | 204 | 84.0 |

† For altitudes above 2,000 ft. rating should be reduced at the rate of 4% for each 1,000 ft. above sea level. Heating Capacity is based on D.O.E. (Department of Energy) test procedure.

⁽¹⁾ Add model number suffix 'P' for Propane.

⁽²⁾ Net AHRI Water rating shown based on piping and pickup allowance of 1.15. Consult manufacturer before selecting boiler for installations having unusual piping and pickup requirements, such as intermittent system operation, extensive piping systems, etc.

⁽³⁾ MBH = 1,000 Btuh = British Thermal Unit Per Hour

- Ratings marked "Net AHRI Ratings" indicate amount of remaining heat input used to heat radiation or terminal units. Net AHRI Ratings shown are based on allowance of 1.15 in accordance with factors shown on AHRI Standard as published by The Hydronics Institute.
- Selection of boiler size should be based upon "Net AHRI Rating" being equal to or greater than calculated heat loss of the building.
- Consult manufacturer before selecting boiler for installations having unusual piping and pickup requirements.

BOILERS FOR USE AT HIGH ALTITUDE

Boiler is factory equipped for use at altitudes of 0-2,000 feet above sea level.

For use at altitudes above 2,000 feet above sea level, input ratings are reduced by change in main burner orifice size.

For altitudes above 2,000 feet above sea level, input ratings should be reduced at rate of 4% for each 1,000 feet above sea level. Consult National Fuel Gas Code (NFPA54/ANSI Z223.1-latest edition), or manufacturer for correct orifice sizing information.

⚠ WARNING

Burn and scald hazard. Do not add water until boiler has fully cooled. Failure to follow these instructions could result in death or serious injury.

Control - LED legend

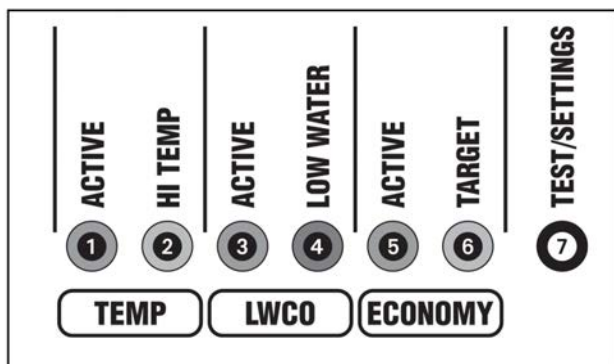

- 1 **TEMP ACTIVE** Indicates the Fuel Smart HydroStat control is powered and the temperature function is active.
- 2 **TEMP HI TEMP** Illuminates when the boiler water temperature reaches the high limit setting. It will remain lit until the water temperature falls 10°. The Fuel SmartHydroStat prevents burner operation while this LED is on. See Differential explanation on page 6 of Hydrolevel Manual.
- 3 **LWCO ACTIVE** Indicates the low water cut-off (LWCO) function of the Fuel Smart HydroStat is active. When the control is installed with a Hydrolevel Electro-Well, this LED will be on at all times when the control is powered.
IMPORTANT: If the control is installed with a well other than the Electro-Well, this LED will not illuminate indicating the control is not providing low water cut-off functionality.
- 4 **LWCO LOW WATER** Indicates the boiler is in a low water condition. The HydroStat control will prevent burner operation during this condition. If the LOW WATER light is blinking, the control has been programmed to provide lockout protection in the event a low water condition is detected. (see Manual Reset Low Water Cut-Off on page 8 of Hydrolevel manual). Pressing the TEST/SETTINGS button will reset the control.
IMPORTANT: The system must be checked by a qualified heating professional prior to resuming operation.
- 5 **ECONOMY ACTIVE** Indicates the Thermal Targeting function is active and the Fuel Smart HydroStat will reduce boiler temperature to conserve fuel. The Economy feature is activated using the ECONOMY dial.

- 6 **ECONOMY TARGET** When the Economy feature is active, the Fuel Smart HydroStat continually sets target temperatures below the high limit setting to maximize fuel efficiency. When the boiler water reaches the target temperature, the LED illuminates and the burner will shut down. The boiler water will continue to circulate and heat the house as long as the thermostat call continues. The LED will stay lit until the boiler temperature drops below the differential set point at which point the boiler will be allowed to fire again.
See Differential explanation on page 6 of Hydrolevel Manual.
NOTE: This LED illuminates regularly during normal boiler operation

- 7 **TEST/SETTINGS Button**
To Test Low Water Cut-Off: Press and hold the Test/Settings button for 5 seconds. The display will read LCO.
LWCO TEST LCO
The red Low Water light should illuminate and the burner circuit (B1 and B2) should de-energize. **NOTE:** The control must be installed with a Hydrolevel Electro-Well for low water cut-off functionality (see page 2 of Hydrolevel manual for more details).
To View Current Settings: Press and release the Test/Settings Button in short intervals to sequentially display the following settings:

HIGH LIMIT SETTING HL
▼
LOW LIMIT SETTING LL
▼
ECONOMY SETTING ECO

CURRENT TARGET TEMPERATURE 000
The display will return to boiler temperature (default) if Test/Settings Button in not pressed for 5 seconds.

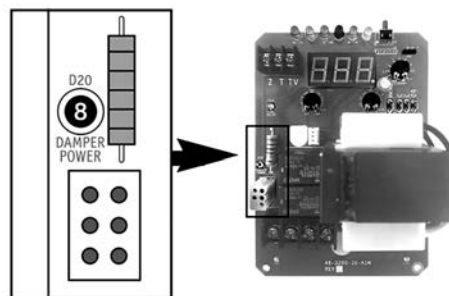

- 8 **DAMPER POWER LED**
Indicates the control is energizing the vent damper. For applications where the vent damper is not plugged into the HydroStat, the LED indicates the burner circuit (B1 - B2) is powered. LED will blink when power is sent to the Vent Damper and will turn solid when power returns from the end switch.

If this LED is blinking and the burner is not firing:

1. Make sure the plug connection (or jumper, on boilers where vent damper plug is not used) is secure.
2. Make sure the plug connection at the vent damper end is secure and oriented correctly.
3. Make sure damper motor turns.
4. Verify the damper end switch has closed

⚠ DANGER

Carbon Monoxide Hazard: If the burner fires when the vent damper is not fully opened or there is any other blockage in the flue, dangerous flue products, such as carbon monoxide, will escape into the living space causing severe personal injury or death. The flue as well as the vent damper must be checked for proper operation before allowing the system to operate.

9 Circ Delay LED

The blue “circ delay” LED lights to indicate the heating circulator (terminal C1) is being held off. See Circulator Hold Off (option 5) top of page 9 of the Hydrolevel manual for more information.



Intermittent Pilot

Ignition System Checks

STEP 1: Check ignition cable.

- Verify ignition cable does not touch metal surfaces.
- Verify only factory supplied Ignition cable (or approved replacement) is used.
- Verify connections to ignition module and igniter or igniter-sensor are clean and tight.
- Verify ignition cable provides good electrical continuity.

STEP 2:

Verify ignition system grounding. Nuisance shutdowns are often caused poor or erratic grounding.

Common ground is required for module and pilot burner/igniter sensor.

- Check for good metal-to-metal contact between pilot burner bracket and the main burner.
- Check ground lead from GND (BURNER) terminal on module to pilot burner. Verify connections are clean and tight. If wire is damaged or deteriorated, replace with No. 14-18 gauge, moisture-resistant, thermoplastic insulated wire with 105°C [221°F] minimum rating.
- Check ceramic flame rod insulator for cracks or evidence of exposure to extreme heat, which can permit leakage to ground. Replace pilot burner/igniter sensor and provide shield if necessary.
- If flame rod or bracket is bent out of position, restore to correct position.

STEP 3: Check spark ignition circuit.

Disconnect ignition cable at SPARK terminal on module.

⚠ WARNING





Electrical shock hazard. Ignition circuit generates over 10,000 volts. Turn OFF electrical power supply at service panel before making electrical connections. Failure to do so could result in death or serious injury.

Energize module and listen for audible sparking noise. When operating normally, there should be buzzing noise turns on and off twice per second for duration of 1–7 seconds, depending on model.

STEP 4: Verify pilot and main burner light-off.

- Initiate call for heat. Turn thermostat above room temperature. Ignition sequence may be delayed by thermal purge until boiler water temperature is below 140°F (60°C)
- Watch pilot burner during ignition sequence:
 - Verify ignition spark continues after pilot is lit.
 - Verify pilot lights and spark stops, verify main burner does not light.
- If so, ensure adequate flame current as follows:
 - Turn off boiler at circuit breaker or fuse box.
 - Clean flame rod with emery cloth.
 - Verify electrical connections are clean and tight. Replace damaged wire..
 - Check for cracked ceramic insulator, which can cause short to ground, and replace igniter-sensor if necessary.
 - At gas valve, disconnect main valve wire from MV terminal.
 - Turn on power and set thermostat to call for heat. Pilot should light, main burner will remain off because main valve actuator is disconnected.
 - Check pilot flame. Verify it is blue, steady and envelops 3/8 to 1/2 in. [10 to 13 mm] of flame rod. See Figure 16 for possible flame problems and causes.
 - If necessary, adjust pilot flame by turning pilot adjustment screw on gas control clockwise to decrease or counterclockwise to increase pilot flame. Following adjustment, always replace pilot adjustment cover screw and tighten firmly to assure proper gas control operation. Figure 13, page 22.
 - Set temperature below room set-point to end call for heat.
- Recheck ignition sequence as follows:
 - Reconnect main valve wire.
 - Adjust thermostat above room temperature.
 - Verify ignition sequence at burner.
 - If spark does not stop after pilot lights, replace module.
 - If main burner does not light or if main burner lights and system locks out, check module, ground wire and gas control as described in troubleshooting table. See Table 6 page 25, and Table 7 page 33.

Figure 16 - Troubleshooting Pilot Flame

| APPEARANCE | CAUSE |
|---|---|
| <p>SMALL BLUE FLAME</p>  | <p>CHECK FOR LACK OF GAS FROM:</p> <ul style="list-style-type: none"> • CLOGGED ORIFICE FILTER • CLOGGED PILOT FILTER • LOW GAS SUPPLY PRESSURE • PILOT ADJUSTMENT AT MINIMUM |
| <p>LAZY YELLOW FLAME</p>  | <p>CHECK FOR LACK OF AIR FROM:</p> <ul style="list-style-type: none"> • DIRTY ORIFICE • DIRTY LINT SCREEN, IF USED • DIRTY PRIMARY AIR OPENING, IF THERE IS ONE • PILOT ADJUSTMENT AT MINIMUM |
| <p>WAVING BLUE FLAME</p>  | <p>CHECK FOR:</p> <ul style="list-style-type: none"> • EXCESSIVE DRAFT AT PILOT LOCATION • RECIRCULATING PRODUCTS OF COMBUSTION |
| <p>NOISY LIFTING BLOWING FLAME</p>  | <p>CHECK FOR:</p> <ul style="list-style-type: none"> • HIGH GAS PRESSURE |
| <p>HARD SHARP FLAME</p>  | <p>THIS FLAME IS CHARACTERISTIC OF MANUFACTURED GAS</p> <p>CHECK FOR:</p> <ul style="list-style-type: none"> • HIGH GAS PRESSURE |

Correct Pilot Flame: 3/8 to 1/2 inch in flame. See Figure 15, Page 23.

A.1 Vent Damper Harness - Molex Plugs

⚠ WARNING

Do Not negate the action of any existing safety operational controls. Avoidance of these instructions could result in death or serious injury.

Note When servicing controls, all wires must be labeled prior to disconnection. Wiring errors can cause improper and dangerous operation. Do not turn damper open manually or motor damage will result and void all warranties, use the service switch.

DO NOT CUT PLUG OFF OF DAMPER MOTOR ASSEMBLY OR WARRANTY WILL BE VOID.

Check Molex Plugs on Vent Damper Harness:

Note Damper wiring harness is made up of 4 individual colored wires, Brown, Black, Yellow, and Orange (refer to drawing below).

1. Disconnect thermostat wires.
2. Use the two diagrams below to confirm the Molex plugs on each end of the damper harness are wired and operating properly.

Damper end of wiring harness:

- A. Hold plug in hand with wiring harness behind Molex with "V" slot on top. Verify wire colors are in proper position.
- B. Take reading across brown and black wires in Molex plug, using test meter set for AC volts. 24 volts should be present.
 - i. IF NOT, source of the problem is not in damper; check line voltage and 24 volt supply.
 - ii. If 24 volts is present across brown and black, continue to step iii.
 - iii. Reconnect thermostat wires and turn up heat setting.
 - iv. Check voltage across black and orange wires in Molex plug. 24 volts AC should be present:
 - IF NOT, source problem is not the damper.
 - If 24 volts is present continue on to step v.
 - v. Place jumper wire across orange and yellow wires in Molex plug (see Below). This will create bypass of the damper, boiler should then ignite.
 - IF NOT, source problem is not the damper. Go to "AquaStat end of wiring harness"

- If boiler ignites: Go to section A.2 "Vent Damper Troubleshooting Guide". **NOTE:** Prior to replacing the damper, be sure the problem is not with wire connections between damper and wiring harness.

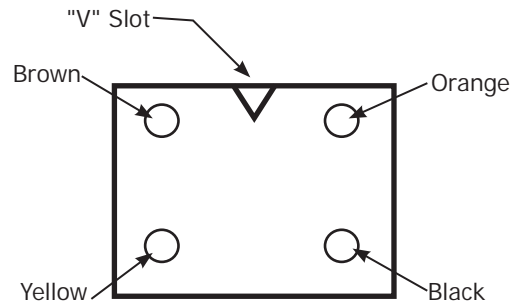

Control End of wiring harness

Hold plug in hand with wiring harness behind Molex with "V" slot on top. Verify wires colors are in proper position

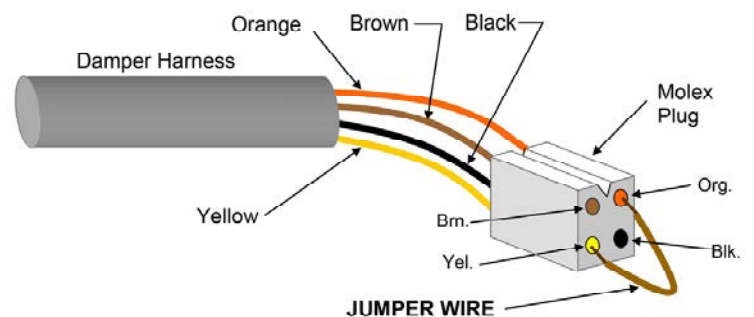
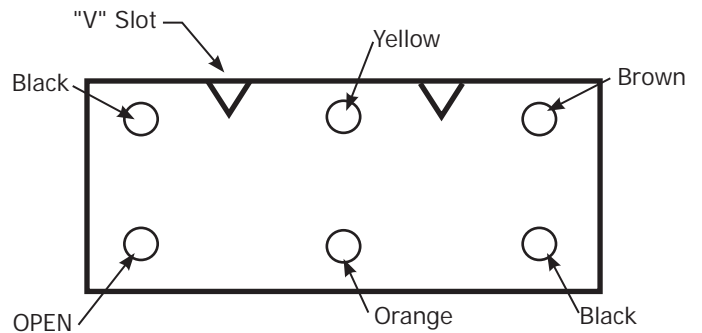

- A. Remove damper harness from control. Jump Molex connector on control board between two center holes using ~18ga. thermostat wire.
 - i. If boiler ignites, replaces damper harness
 - ii. If boiler does not light, replace control.

A.2 Vent Damper Troubleshooting Guide

WARNING

Do Not negate the action of any existing safety operational controls. Avoidance of these instructions could result in death or serious injury.

Note When servicing controls, all wires must be labeled prior to disconnection. Wiring errors can cause improper and dangerous operation. Do not turn damper open manually or motor damage will result and void all warranties, use the service switch.

DO NOT CUT PLUG OFF OF DAMPER MOTOR ASSEMBLY OR WARRANTY WILL BE VOID.

Normal Sequence of Operation

| 24 VAC Power | Power ON | Damper Position |
|--------------|-------------------|-----------------|
| 4 & 1 | All times | Open or Closed |
| 4 & 2 | Calling for Heat | Open or Opening |
| 4 & 3 | During combustion | Damper Open |



Table 7 - Vent Damper Troubleshooting

| Problem | Possible Cause | Recommended Solution |
|--|--|--|
| NO POWER Between 4 & 1 | <ol style="list-style-type: none"> Off on limit (120VAC) Bad transformer Loose or broken connections Blown fuse or circuit breaker Disconnect switch off Harness not plugged into receptacle | <ol style="list-style-type: none"> turn limit on Replace transformer Tighten, repair, or replace connection Replace fuse or reset circuit breaker Turn switch on Plug harness in |
| NO POWER Between 4 & 2 POWER Between 4 & 1 When calling for heat | <ol style="list-style-type: none"> Thermostat not calling for heat Burned out heat anticipator Loose or broken connections Off/On operating limit, pressure control or low water cut off Off/On blocked vent switch or flame roll out | <ol style="list-style-type: none"> Turn thermostat up to call for heat Replace thermostat Tighten, repair, or replace connection Turn operating limit, pressure control, or low water cutoff ON Reset or replace switch |
| POWER Between 4 & 1 Between 4 & 2 DAMPER OPEN | <ol style="list-style-type: none"> Loose or broken connection Defective damper motor | <ol style="list-style-type: none"> Tighten, repair, or replace connection Replace damper motor assembly |

Note

For troubleshooting only. Verify damper is in open position. Use service switch to keep damper in open position. Place jumper between 2 & 3. If appliance fires, remove jumper and plug receptacle back into damper controller plug. If appliance does not fire, replace damper motor assembly. Do not replace pipe assembly.

If damper motor assembly is not available, place service switch in hold open position. This should keep damper in open position and allow customer to have automatic heat. Return or replace the motor assembly at your convenience. Motor assembly carries 18 month limited commercial warranty from the original date of purchase. (Refer to form #4294 on vent damper manufacturers website). Pipe assembly is not warranted.

Table 8 - Trouble Shooting with Jumper Wire In Place

| Problem | Possible Cause | Recommended Solution |
|---|---|---|
| NO POWER Between 4 & 1 Between 4 & 2 Between 4 & 3 Damper OPEN NO COMBUSTION | <ol style="list-style-type: none"> 1. Is gas turned on 2. Operating limit, pressure control, low water cut off not on. 3. Blocked vent switch or flame roll out switch tripped 4. Loose or broken connection 5. Defective component in appliance after vent damper | <ol style="list-style-type: none"> 1. Verify gas is on 2. Verify operating limit, pressure control or low water cut off is on 3. Reset or replace blocked vent switch or flame roll out switch 4. Tighten, repair, or replace connection 5. Replace defective component in appliance |
| Damper Sticks | <ol style="list-style-type: none"> 1. Damper blade obstruction 2. Damper pipe egg shaped, out of round/binding. 3. Crimped end of vent piece inserted in too far | <ol style="list-style-type: none"> 1. Clear the obstruction 2. Restore to damper pipe to round, verify not binding. 3. Correct the condition |
| Damper Rotates Continuously | <ol style="list-style-type: none"> 1. Defective damper motor assembly | <ol style="list-style-type: none"> 1. Replace damper motor assembly |

IMPORTANT

In accordance with Section 325 (f) (3) of the Energy Policy and Conservation Act, this boiler is equipped with a feature that saves energy by reducing the boiler water temperature as the heating load decreases. This feature is equipped with an override which is provided primarily to permit the use of an external energy management system that serves the same function.

THIS OVERRIDE MUST NOT BE USED UNLESS AT LEAST ONE OF THE FOLLOWING CONDITIONS IS TRUE:

- An external energy management system is installed that reduces the boiler water temperature as the heating load decreases.
- This boiler is not used for any space heating
- This boiler is part of a modular or multiple boiler system having a total input of 300,000 BTU/hr or greater.
- This boiler is equipped with a tankless coil.



2201 Dwyer Avenue, Utica, NY 13501
Tel. 800 253 7900
www.ecrinternational.com

All specifications subject to change without notice.
©2020 ECR International, Inc.