



# Dunkirk Boilers DCB-165 Submittal



Engineer: \_\_\_\_\_

Project Name: \_\_\_\_\_

Project Location: \_\_\_\_\_

Contractor: \_\_\_\_\_

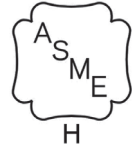

### APPLICATION:

Modulating Gas fired water boiler for indoor installation. Approved for closet or alcove installations. For use with natural or liquefied petroleum (LP/Propane) fuel gases. Wall mounted – optional floor stand available. All boilers are factory assembled with controls and wiring and test fired to ensure dependable performance. Boiler shall be certified for Direct Vent applications only.

### CERTIFICATION AND APPROVALS:

Stainless Steel heat exchanger is manufactured and tested in accordance with American Society of Mechanical Engineers (ASME) and certified by Canadian Standards Association (CSA), AHRI, NRCAN. Registered with National Board BPVI, and Massachusetts Board. Stainless steel heat exchanger is tested for maximum allowable working pressure of 50 psig in accordance with ASME boiler and pressure vessel code, section IV, rules for construction of heating boilers. A 30 psig safety relief valve is shipped standard.

### BOILERS INCLUDE:

- Wall mount bracket, mounting hardware and actual size Wall Mount Template
- Boiler includes factory installed and wired 2 speed, electronically controlled, step modulating circulator pump. The circulator RPM is determined by the boiler temperature and controlled by the integrated boiler control.
- External Primary/Secondary manifold with quick connections shipped with boiler.
- Digital Boiler Control:
  - ▶ Control is Self Commissioning, automatically recognizes fuel type (Natural or LP gas).
  - ▶ Control monitors flame signal and automatically adjusts the gas valve during operation for optimum combustion and maximum efficiency.
  - ▶ Control system is PCB integral controller with LCD digital/graphical display.
  - ▶ Control can sense and display water temperature and indicate when boiler is in central heating or domestic water mode.
  - ▶ Control can accept an optional Outdoor Air sensor and has field adjustable reset curves.



Manufactured by:  
 ECR International Inc.  
 2201 Dwyer Avenue, Utica, NY 13501  
 Tel. 800 325 5479  
[www.ecrinternational.com](http://www.ecrinternational.com)  
 PN 240012339 REV. F [10/15/2021]



- ▶ Control displays Error Codes and Diagnostic information.
- ▶ Control can accept 0-10V input to manage heating set-point or heating power level.
- Boiler Combustion System:
  - ▶ The Gas valve is a modulating valve capable of firing from 164,000 BTU input down to 29,500 BTU input in Heat mode (5.5:1 turn down).
  - ▶ Induced draft blower is variable speed controlled by the PCB.
  - ▶ Burner is constructed of Iron-Chromium stainless steel.
  - ▶ Ignition system shall incorporate a Direct Spark Igniter and a separate Flame Sensing rod.
- Heat Exchanger:
  - ▶ Boiler's primary heat exchanger is constructed of Iron-Chromium stainless steel.
- Electrical
  - ▶ 120 volts AC, 60 Hertz, 1-phase; less than 15 amps.
  - ▶ Factory wired 3-foot appliance cord with male plug end.
  - ▶ Low voltage terminal strip for Thermostat, Outdoor Air Sensor, Indirect Tank sensor.
- Warranty
  - ▶ Factory Standard Limited Warranty is 10 years on heat exchanger, one year on parts.
  - ▶ Please see the Limited Warranty for More Detail on Warranty Registrations & Extensions.
- Optional Equipment
  - ▶ Outdoor Air Sensor Kit
  - ▶ Indirect Tank Sensor Kit
  - ▶ Coaxial and Two-pipe venting components
  - ▶ Floor Stand Kit





Size	Boiler Input Rate (MBH) <sup>(1)</sup>		Heating Capacity (MBH) <sup>(1)(2)</sup>	Net AHRI Rating, Water (MBH) <sup>(1)(3)</sup>	AFUE <sup>(2)</sup>
	Maximum	Minimum			
<b>DCB-165</b>	164	19.5	153	133	95.0

<sup>(1)</sup>1000 Btu/hr (British Thermal Units Per Hour)

<sup>(2)</sup>Heating Capacity and AFUE (Annual Fuel Utilization Efficiency) are based on DOE (Department of Energy) test procedures.

<sup>(3)</sup>Net AHRI Ratings based on piping and pickup allowance of 1.15. Contact Technical Support before selecting boiler for installations having unusual piping and pickup requirements, such as intermittent system operation, extensive piping systems, etc.

\*Max CH Supply temp 176° F (80°C) for DCB165 \*Max DHW temp 140° F (60° C)

<b>Dunkirk Boiler DCB-165</b>	
<b>Minimum Clearances for Servicing</b>	
Top	8.66 in / 220.00 mm
Bottom	9.84 in / 250.00 mm
Sides	1.77 in / 45.00 mm
Front	17.71 in / 450.00 mm
Flue Terminal Size Concentric System	3.93 in / 100.00 mm
Flue Terminal Size 2-Pipe Flue System	3.14 in / 80.00 mm
Flue Terminal Protruding	4.52 in / 115.00 mm

<b>Dunkirk Boiler DCB-165</b>	
<b>Central Heating (Sealed System)</b>	
Max System Pressure	43.00 psi / 2.96 bar
Min System Pressure	7.25 psi / 0.50 bar
Max System Temperature	176°F / 80°C
Pressure Relief Valve Setting	30.00 psi / 2.11 bar
Flow Connection	1" / 25.4 mm NPT
Return Connection	1" / 25.4 mm NPT
Relief Valve Connection	3/4" / 22.2 mm NPT
Recommended Operating System Pressure	21.7 psi / 1.5 bar



Manufactured by:  
 ECR International Inc.  
 2201 Dwyer Avenue, Utica, NY 13501  
 Tel. 800 325 5479  
[www.ecrinternational.com](http://www.ecrinternational.com)  
 PN 240012339 REV. F [10/15/2021]

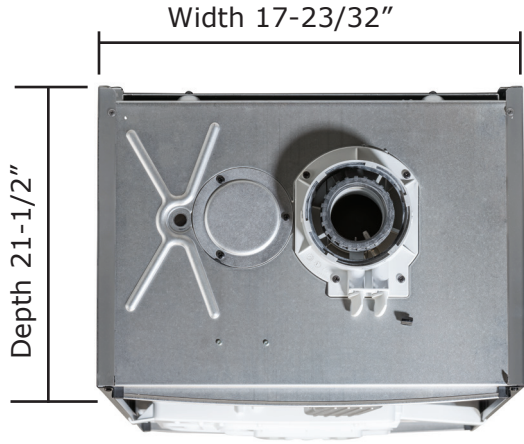

View - Front of Boiler

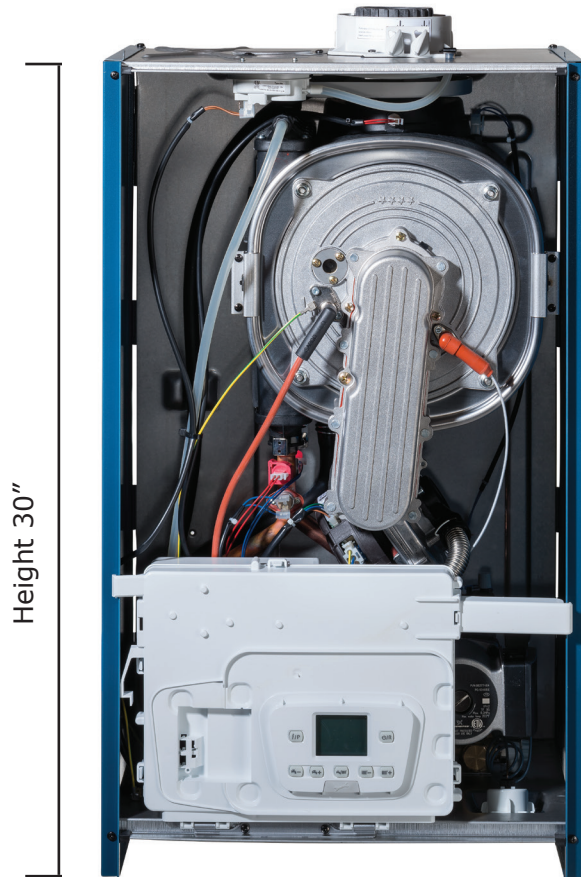

## Venting

<p><b>Coaxial Venting</b> Connects directly to the top of the boiler</p>	
<p><b>2-Pipe Venting - Optional Kit</b> Using polypropylene - 80 mm venting</p>	
<p><b>2-Pipe Venting - Optional Kit</b> Using CPVC UL1738/S626 - 3" venting</p>	

Total Vent Equivalent Lengths* - Account For Fittings As Listed					
Vent Size	Coaxial 4"/2" [100/60]	Twin Pipe			CPVC UL1738/ S636 3" [80 mm]
		Rigid	Flexible		
		3" [80 mm]	2" ** [60 mm]	3" [80 mm]	
Total Maximum	32.8 ft [10 m]				
Air Intake Maximum		49 ft [15 m]	85 ft [25.9 m]	50 ft [15.2 m]	49 ft [15 m]
Intake + Exhaust		196.8 ft [60 m]	170 ft [51.8 m]	130 ft [40 m]	196.8 ft [60 m]
90° elbows	3.28 ft [1.0 m]	1.64ft [0.50 m]	3 ft [0.91 m]	1.64ft [0.50 m]	1.64 ft [0.50 m]
45° elbows	1.64 ft [0.50 m]	0.82 ft [0.25 m]	5 ft [1.5 m]	0.82 ft [0.25m]	0.82 ft [0.25 m]

\* Refer to IOM for complete venting details.  
\*\* Use venting manufacturer's components to transition from 3" [80 mm] to 2" [60 mm]