

Oil Fired Steam Boiler Heat Exchanger Replacement and Low Water Cut Off Probe Relocation SERIES 4 TO SERIES 5 Conversion Instructions

WARNING

This conversion kit shall be installed by a qualified service agency in accordance with the manufacturer's instructions and all applicable codes and requirements of the authority having jurisdiction. If the information in these instructions is not followed exactly, a fire, an explosion or production of carbon monoxide could result in personal injury or loss of life. The qualified service agency is responsible for the proper installation of this kit. The installation is not proper and complete until the operation of the converted appliance is checked as specified in the manufacturer's instructions supplied with the kit.

WARNING

Fire, explosion, asphyxiation and electrical shock hazard. Improper installation could result in death or serious injury. Read this instruction and understand all requirements, including requirements of authority having jurisdiction, before beginning installation. Installation not complete until appliance operation verified per Installation, Operation & Maintenance Manual provided with boiler.

WARNING

Burn and scald hazard. Components shall be installed by qualified service agency in accordance with manufacturer's instructions and all applicable codes and requirements of authority having jurisdiction. Verify Boiler is off and cooled before component installation. Failure to follow these instructions could result in death or serious injury.

CAUTION

Laceration, burn hazard. Metal edges and parts may have sharp edges and/or may be hot. Use appropriate personal protection equipment to include safety glasses and gloves when installing or servicing this boiler. Failure to follow these instructions could result in minor or moderate injury.

For Use with the following Kits:

550002714	3 Section Heat Exchanger Kit, with Cover Plate
550002715	4 Section Heat Exchanger Kit, with Cover Plate
550002716	5 Section Heat Exchanger Kit, with Cover Plate
550002717	6 Section Heat Exchanger Kit, with Cover Plate
550002718	3 Section Heat Exchanger Kit, with Tankless Coil
550002719	4 Section Heat Exchanger Kit, with Tankless Coil
550002720	5 Section Heat Exchanger Kit, with Tankless Coil
550002721	6 Section Heat Exchanger Kit, with Tankless Coil

Kit Includes:		
Part Number	Description	QTY
‡	Heat Exchanger with Rear Section Baffle	1
2552701	Target Wall	1
‡	Blanket Insulation	1
240012195	Remote LWCO Probe	1
240012147	Remote LWCO Probe Wiring Harness	1
14634032	Strain Relief Bushing for Probe Wiring Harness	1
240012204	Template for Rear Jacket Panel	1
240012208	Template for Upper Front Jacket Panel	1
109010090	LWCO Mounting Bracket	1
14695074	#10 x 1/2" Sheet Metal Screw	4
14695004	#8-32 x 3/8" Sheet Metal Screw	2
14695060	#10x 1/2" Drill Screw	1
2200201	Cable Hanger	1
14691002	Cable Tie	1
240012148	Wiring Diagram Label	1
620000494	Series 5 Conversion Label	1
240012205	Instructions	1

‡ Refer to Replacement Parts listings in this document for part number per boiler size.

INSTALLATION INSTRUCTIONS

1. General Information

Use of this kit will move the low water cut off (LWCO) probe from the front boiler section to the rear boiler section, converting the boiler from a Series 4 design to a Series 5 design.

The low water cut off control remains mounted in the same location on the front of the boiler but is now installed on a mounting bracket instead of on the low water cut off probe. The new low water cut off probe is mounted remotely in the rear section.

2. Installation Instructions:

1. Remove the following components from the original heat exchanger and set removed components aside for reinstallation on new heat exchanger.
 - a. Right and left side lower cowl panels
 - b. Disconnect oil line and remove oil burner
 - c. Controls and wiring (existing low water cut off probe in front section will not be reused)
 - d. Piping
 - e. Remaining jacket panels and jacket hardware
 - f. Burner mounting door and door hardware
2. Move stripped down original heat exchanger aside and place new heat exchanger in correct location.
3. Install furnished target wall all the way into the combustion area up against the back wall.
4. Lay furnished blanket insulation in the combustion area and up against the target wall edge.
5. Reinstall burner mounting door.
6. Install furnished remote low water cut off probe in open $\frac{3}{4}$ " NPT tapping in rear boiler section using pipe dope. Do not use Teflon tape on probe threads. See **Figure 1**.
7. Use furnished template 240012204 and add 2" diameter hole to the back jacket panel following the instructions on the template. Take care to not damage the existing jacket panel insulation.
8. Use furnished template 240012208 and drill four (4) $\frac{1}{8}$ " holes in the upper front jacket panel following the instructions on the template. Take care to not damage the existing jacket panel insulation.
9. Reinstall jacket panels (except lower cowl panels) on new heat exchanger.
10. Reinstall all piping on new heat exchanger.
11. Install furnished low water cut off mounting bracket on upper front jacket panel using holes drilled in step 8. Use four (4) furnished #10 x $\frac{1}{2}$ " sheet metal screws. See **Figure 3**.

Figure 1 - Low Water Cutoff (LWCO) Probe Location

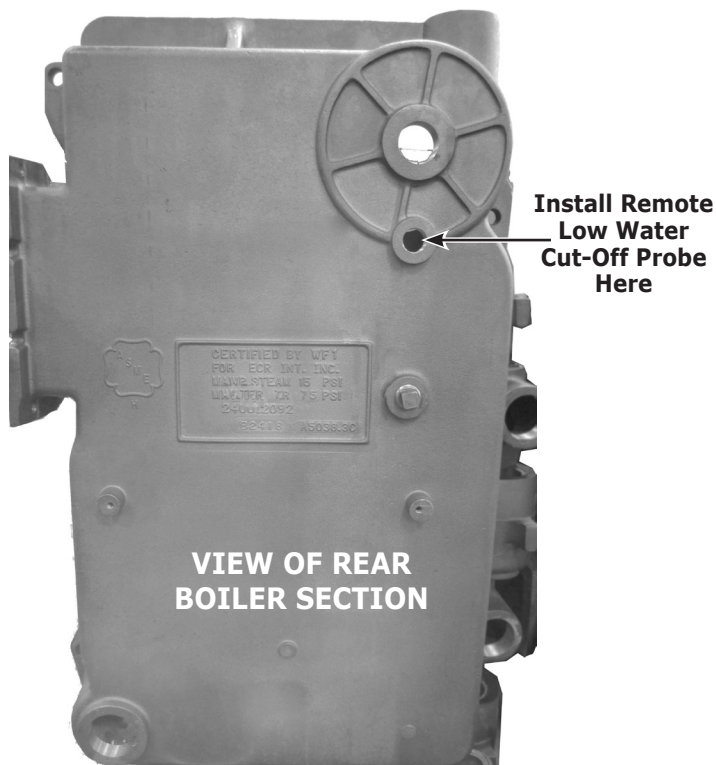

Figure 2 - Low Water Cutoff (LWCO) Probe Wiring



INSTALLATION INSTRUCTIONS

12. Install low water cut off control to low water cut off mounting bracket using two (2) furnished #8-32 x 3/8" screws. See **Figure 3**.
13. Remove existing low water cut off probe wire from low water cut off control and discard wire.
14. Install furnished low water cut off probe wire and furnished strain relief bushing into low water cutoff control using an available electrical knockout. Connect wire to PROBE terminal inside control. Connect other end of wire with ring terminal to low water cut off probe in rear boiler section, securing with lock washer and wing nut.
15. Insert furnished cable hanger over low water cut off probe wire. Attach cable hanger to left side panel with #10 x 1/2" drill screw such that it holds the low water cut off probe wire level. Locate drill screw at approximate midpoint of panel. See **Figure 2**.
16. For 6 section boilers, the low water cut off probe wire is just the right length and there should be no slack. For 3/4/5 section boilers, use the furnished cable tie to take up any slack in the low water cut off probe wire. See **Figure 2**.
17. Reinstall remaining controls and wiring. See **Figure 3**.
18. Reinstall oil burner and connect oil line.
19. Apply furnished wiring diagram label over top of original wiring diagram label.
20. Apply furnished Series 5 Conversion Label to top left corner of upper front panel just above the low water cut off control.

Figure 3 - LWCO Mounting and Other Control Details

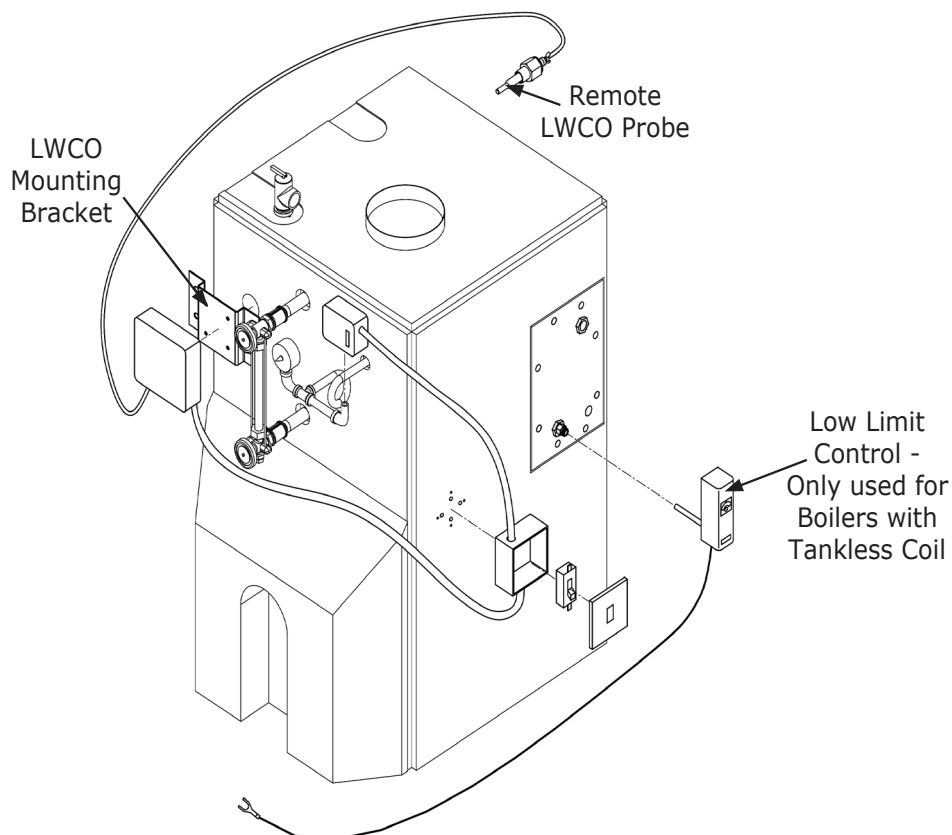

INSTALLATION INSTRUCTIONS

CONTROL WIRING FOR OIL FIRED STEAM BOILER

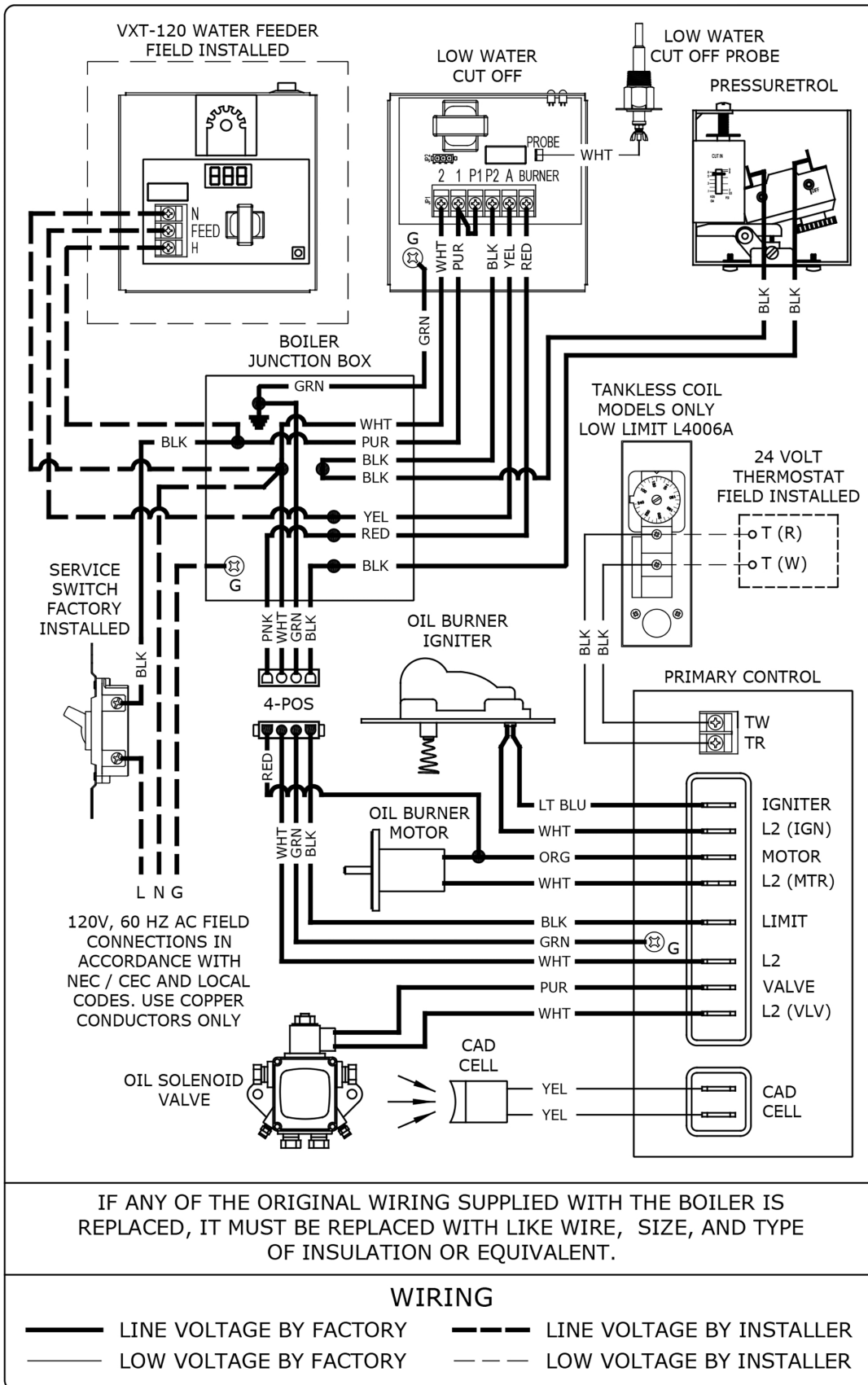

OPERATING INSTRUCTIONS

Filling System with Water

Steam boilers are partially filled with water. Fill boiler to normal water line for proper system operation. Normal water line is 28" from the bottom of the boiler as shown on the label on front of boiler and **Figure 4**.

1. Close boiler drain valve.
2. Open valves at top and bottom of glass water level gauge. Close petcock on bottom of lower gauge glass fitting.
3. Open fill valve and allow water to run into boiler.
4. Continue to fill boiler until water reaches indicated water line.

Normal Water Line

- Normal water line is 28" from bottom of the boiler and shown on label on the front of the boiler.
- Normal water line is determined with the boiler off and cold, when all water in the system is inside the boiler and return piping below the water line and everything above the water line is air, no steam.
- When boiler is making steam, actual water level drops below the normal water line.

Sequence of Operation

On a call for heat, thermostat contacts close, energizing the burner. Ignition system is activated and ignition will begin.

In event of a low water condition, the automatic low water cut off will interrupt power to the burner. The burner will remain off until the low water condition is corrected, either by manually filling the boiler or by utilizing a water feeder device which automatically fills the boiler.

Low Water Cut Off Test

- Before putting boiler in service, test the low water cut off device for proper operation.
- With boiler water level at normal water line, set thermostat to call for heat. The amber LED lamp on the low water cut off control should be off and boiler should fire.
- Slowly lower the water level to a point below low water cut off probe. The amber LED lamp on the control will light. The lamp may flicker first with a bouncing water level. Stop draining the boiler when the light glows steadily. **NOTE:** The water level should not be lowered beyond a visible point in the gauge glass.
- Burner should shut down within 15 seconds.
- Refill boiler to normal water level.
- Refer to Hydrolevel control instructions provided with boiler for additional details and troubleshooting info.

WARNING

Burn, scald Hazard. Water temperatures exceeding 125°F will cause severe burns or death by scalding. Failure to follow these instructions could result in death or serious injury.

Figure 4 - Normal Water Line

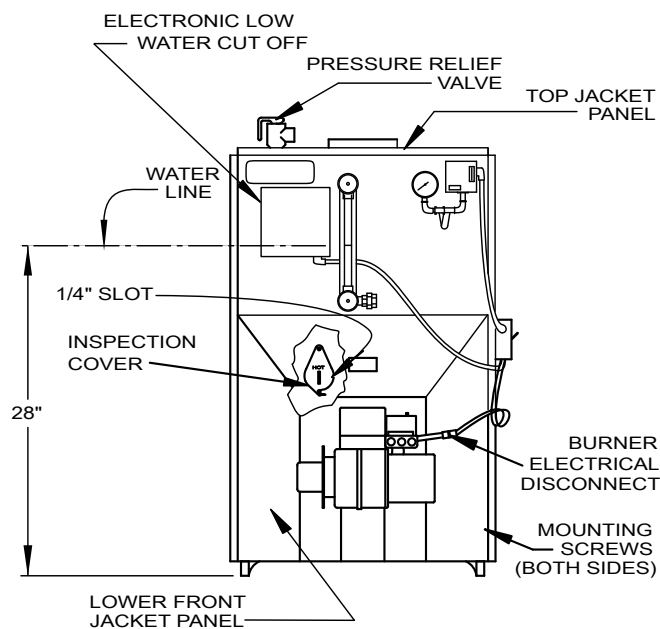

Adjust Steam Pressure Control

- Steam pressure limit control (pressuretrol) shuts off gas to main burners when steam pressure in boiler reaches cut-off setpoint (i.e. sum of cut-in and differential setpoints).
- Burner refires when steam pressure drops to cut-in setpoint.
- System pressure requirements are based on size and condition of pipes, and load.
- Cut-in setting of pressuretrol should never be less than twice the system pressure drop for good system operation.
 - a. In typical single family residence with clean one-pipe heating system and cast iron radiation, cut-in is usually set at minimum setting, i.e. 1/2 psi.
- Steam radiation is sized based on square feet of equivalent direct radiation (EDR). This is based on steam pressure in the radiator of just less than 2 psi.
- Set differential adjustment at 1 psi, i.e. steam pressure required in radiators. Results in cut-off setpoint of 1½ psi.
- Larger systems or other types of systems such as two pipe systems, or systems with convectors or fan coil units, pressuretrol settings need to be determined on system-by-system basis.
- Cut-in setpoint is determined by system pressure drop to furthest radiator or terminal unit. Double system pressure drop as safety factor, resulting in the rule cut-in setting should never be less than twice system pressure drop.
- Differential setpoint is steam pressure required at terminal heating units.

Boiler will now operate in correct pressure range. It maintains enough steam pressure to send steam out to furthest radiator, and not go over optimum steam pressure required at the radiators.

OPERATING INSTRUCTIONS

Start-Up And Adjustment Of Oil Burner

(See oil burner instructions for nozzle and electrode setting)

Do not set fire visually.

Instruments are only reliable method to determine proper air adjustments.

Improperly adjusted burner causes soot and high fuel bills because of incomplete combustion of the fuel oil. This may require excessive boiler maintenance, service costs, and in some instances, house cleaning or redecorating.

Consult a qualified service mechanic to make proper adjustments with smoke tester, CO2 indicator, and draft gauge.

1. Check oil burner nozzle to verify it is tight in adapter. Burner mounting bolts should be tight.
2. Check electrode setting, they may have been jarred out of position during transportation.
3. Set burner air band and air shutter per Preliminary Settings chart below.
4. Set room thermostat to call for heat, or jump thermostat contacts on boiler control.
5. Open all oil line valves.
6. Turn service switch on. Burner should start.
7. On one pipe fuel systems only, bleed pump as soon as burner starts. Allow oil to run until all traces of air in suction line disappear.
8. Turn "OFF" burner and install pressure gauge on pump.
9. Start burner again and check oil pressure for proper setting per chart below. Adjust if necessary.
10. Use draft gauge to adjust draft regulator to obtain -0.02" W C. draft overfire.
11. After operating 10 minutes to warm up boiler, take smoke reading in the flue pipe between boiler and draft regulator. Smoke should be zero.
12. A new boiler may require more than 10 minutes to burn clean due to oil film on new heat exchanger.
13. Gradually close burner's air adjustment to obtain smoke reading showing trace of smoke. Once smoke reading is trace, measure CO2. To provide a safety factor, increase air to reduce CO2 reading by 1/2% to 1%.

Safe Start Check

1. Place jumper across cad cell terminals.
2. Set thermostat to call for heat.
3. Burner must not start. Verify the green light on primary control is on continuously and the control remains in standby mode.
4. End the call for heat and remove cad cell jumper.

Simulate Flame Failure and Ignition Failure

1. Set thermostat to call for heat.
2. After flame is established and burner igniter turns off, close the hand valve in oil supply line.
3. At flame loss, primary control will enter Recycle mode. Verify the green light is flashing. Control will remain in Recycle mode for 60 seconds.
4. After 60 second Recycle period, control will try to restart the system.
5. After 15 second lockout time, primary control will lock out the burner and reset button will flash. Verify burner motor and igniter are off and burner oil solenoid valve is not energized.
6. Open hand valve in the oil line.
7. Click the reset button on primary control and verify red light in the reset button shuts off and burner lights.
8. End the call for heat.

Table 1 -BECKETT AFG PRELIMINARY SETTINGS

BOILER NO.	HEAD TYPE	HEAD SETTING	STATIC PLATE	NOZZLE	PUMP PRESSURE [PSI]	AIR BAND	AIR SHUTTER
3090	L1	--	3 ³ / ₈	0.75-60°B	150	1	3
4125	V1	0	2 ³ / ₄	1.10-60°B	140	1	8
5185	F12	--	2 ³ / ₄	1.50-70°B	150	2	10
6210	F16	--	--	1.75-70°B	145	2	10

IMPORTANT: Check safety control circuit after burner adjustments have been made for satisfactory performance.

START-UP CLEANING

WARNING

Following service procedures must be performed by qualified service agent. Boiler owner shall not attempt these steps. Failure to do so could result in death or serious injury.

It is very important to clean a new steam boiler after it has been installed and put into continuous operation.

This must be done to remove any accumulation of oil, grease, sludge, etc., that may be present in system. These substances may cause boiler water to foam and surge, producing an unsteady water line, throwing water into steam header, and possibly preventing steam generation.

Skimming and Blow-down

WARNING

Burn Scald Hazard. Water temperatures in excess of 125°F. Failure to follow these instructions could result in death or serious injury.

New boilers must be skimmed at time of installation to remove threading oil and other impurities that float on surface of the water.

1. Remove cap from skimmer nipple on back of boiler, and pipe to floor drain or bucket. Extend skimmer piping as necessary to avoid interfering with or damaging the low water cut off probe. Raise water level to skimmer tapping.
2. Fire burner to maintain water temperature of 180-200°F.
3. Feed water to boiler to maintain water level. Adjust water feed rate to maintain continuous flow of 1 gallon per minute. Do not allow boiler to steam.
4. Continue skimming until water runs clear. This may take several hours.
5. Drain boiler completely to remove any foreign material.
6. Fill boiler to water line.
 - Fire burners, allow normal steam pressure to build up.
 - Run connection from boiler drain valve to safe discharge point outside.
 - Shut off burner, open drain valve, allow all of water in boiler to drain out.
 - Close drain valve.
 - Allow boiler to cool, slowly refill boiler to water line.
 - Repeat this step as many times as necessary until blow-down water is clear.
7. Following final blow-down, allow boiler to cool.
 - Add fresh water slowly up to normal water line.
 - Start burner.
 - Maintain at least 180°F for 15 minutes to remove dissolved gasses from fresh water.
 - Shut off burner.

8. Allow system to operate for one week to give majority of system dirt a chance to work its way back to boiler.
 - Check water in gauge glass. Gauge glass should be dry above water line.
 - Water line should not bounce more than one inch when boiler is steaming.
 - If you see water droplets carrying over from top of gauge glass, or excessive bouncing of water line, boiler needs further cleaning.
 - Take water sample and boil it on stove to see if it foams. If it does, this indicates boiler needs to be cleaned.

NOTICE

Clean water with no additives is essential to proper operation of your boiler and heating system. Boiler cleaners and chemical cleaning, if used and not rinsed properly, may be harmful to the system.

If further cleaning is necessary, repeat skimming and blow-down procedure above. A long skim should be all you need to clean the boiler.

In more troublesome cases it may be desirable to flush the system while, in very extreme cases, it may be necessary to chemically clean and flush heating system.

Check water level frequently. Be sure top and bottom valves on gauge glass are always open so actual water level is shown at all times.

WARNING

Burn and scald hazard. Verify Boiler is off and cooled before performing maintenance. Have a qualified service agent perform maintenance. Failure to follow these instructions could result in death or serious injury.

Manufacturer suggests a qualified service agency be employed to make an annual inspection of the boiler and heating system.

Before seasonal start up have a qualified service agency check boiler for soot and scale in flues, change oil filter and nozzle, clean burner and re-adjust burner input rate to maintain proper operation and high operating efficiency.

On steam boilers verify boiler is filled to water line as indicated in **Figure 4**. Gauge valves should be normally open. To remove dirt from gauge glass petcock may be opened to flush out the glass.

Radiator valves on one-pipe steam system must be either wide open or tightly shut. Do not attempt to regulate room temperature by partially closing the radiator valve.

Air vents on steam radiators and the supply main release air from the system. If radiators do not heat satisfactorily, make sure the air vents are clean and operational.

The area around the boiler must be kept clear and free of combustible materials, gasoline and other flammable vapors and liquids.

Free flow of combustion and ventilation air to the boiler and boiler room must not be restricted or blocked.

Periodic inspection and tightening of the tankless heater/cover plate bolts will reduce the risk of leaks.

Boiler Flue Passages

Inspect Boiler and vent pipe for accumulation of soot or scale deposits periodically, at least once every year before start of heating season. When soot is present on section walls and flueways, improper combustion will result, causing additional sooting and scaling until flueways are completely closed. To remove soot and scale from flueways, remove top jacket panel, top clean out plate, and open burner swing door.

Opening Burner Swing Door (See Figure 4)

1. Turn off boiler and allow boiler to cool down.
2. Disconnect burner wiring harness at factory supplied burner electrical disconnect.
3. Loosen screws on sides of lower front jacket panel. Pull bottom part of lower front jacket panel forward and lift lower front panel up and off boiler.

4. Close oil valve and disconnect oil line from burner.
IMPORTANT: Do not open swing door with oil line attached.
5. Remove nut from swing door stud on right hand side of door
6. Swing open burner door to left.
7. Remove blanket insulation on bottom of boiler to prevent damage.
8. Using flue brush, brush soot and scale into bottom of boiler where it can be removed through swing door opening.

NOTICE

Use caution when vacuuming in chamber area to avoid damaging target wall.

9. Replace blanket insulation on bottom of boiler.

Closing Burner Swing Door

1. Swing burner door to right until swing door insulation is slightly compressed and stud is exposed.
2. Attach nut to stud and tighten until built-in stop contacts mounting door.
3. Reconnect oil line to burner.
4. Replace lower front jacket panel and tighten screws.
5. Reconnect burner wiring harness.
6. Turn on power to boiler and bleed oil line.

Oil Burner

- Manufacturer recommends replacing nozzle at start of each heating season.
- Lubricate oil burner motor – if required – with few drops of electric motor oil. Do not over oil.
- Check electrodes for carbon or cracks in insulators.
- Check burner controls.
- Burner should be setup per “Startup and Adjustment of Oil Burner”.

Vent Pipe and Chimney

Check vent piping at least once a season. Verify vent pipe connections to chimney are secure. Verify there are no obstructions in vent pipe or chimney. If vent pipe or chimney show signs of leaking or deterioration, or vent pipe is sagging, repair or replace immediately as necessary.

Safety Valve

Refer to safety valve manufacturer's instructions provided with safety valve.

Low Water Cut Off

Check low water cut off monthly per "*Low Water Cut Off Test*" to verify it is providing proper protection.

Remove low water cut off probe at the beginning of each heating season for inspection and cleaning. Clean any sediment or scale with scouring pad or steel wool. More frequent cleaning may be required on boilers requiring frequent additions of make-up water.

Boiler Water Treatment Other Than Cleaners

In steam systems where the system is tight, free from leaks, and all steam is returned to the boiler as condensate, the amount of make-up water is small. Water treatment is generally not required.

In steam systems with less than 90% of steam being returned as condensate, or with very hard or corrosive make-up water, treatment may be desirable. Follow recommendations of your local boiler water treatment specialist.

Foaming, Priming or Surging

These terms describe a fluctuating water line, causing water to leave the boiler with steam. It is caused by any combination of the following:

1. Threading oil and/or organic matter in boiler water. Follow instructions under section: **START-UP CLEANING.**
2. Faulty quick vents that do not release air until sizeable pressure is built up. If old style – replace. If dirty – clean until you can easily blow through valve.
3. Adjustment of steam pressure control to wide differential increases difficulty if quick vents are old style, slow releasing type, or dirty. Always set steam pressure control differential as low as possible.
4. Soap and chemicals in boiler water cause extreme surging. Boiler cleaners and chemical cleaning additives are not recommended. If used and not rinsed properly, may be harmful to the system.

Following replacement parts listings apply to the boiler after conversion to Series 5. These listings supersede Series 4 parts lists originally provided with the boiler.

Ordering Instructions

Order Parts through your nearest supplier.

When ordering parts, obtain Model Number and Serial Number from data plate on your boiler.

Include following information when ordering.

Part Number _____

Part Description _____

Boiler Model Number _____

Boiler Serial Number _____

REPLACEMENT PARTS

JACKETS

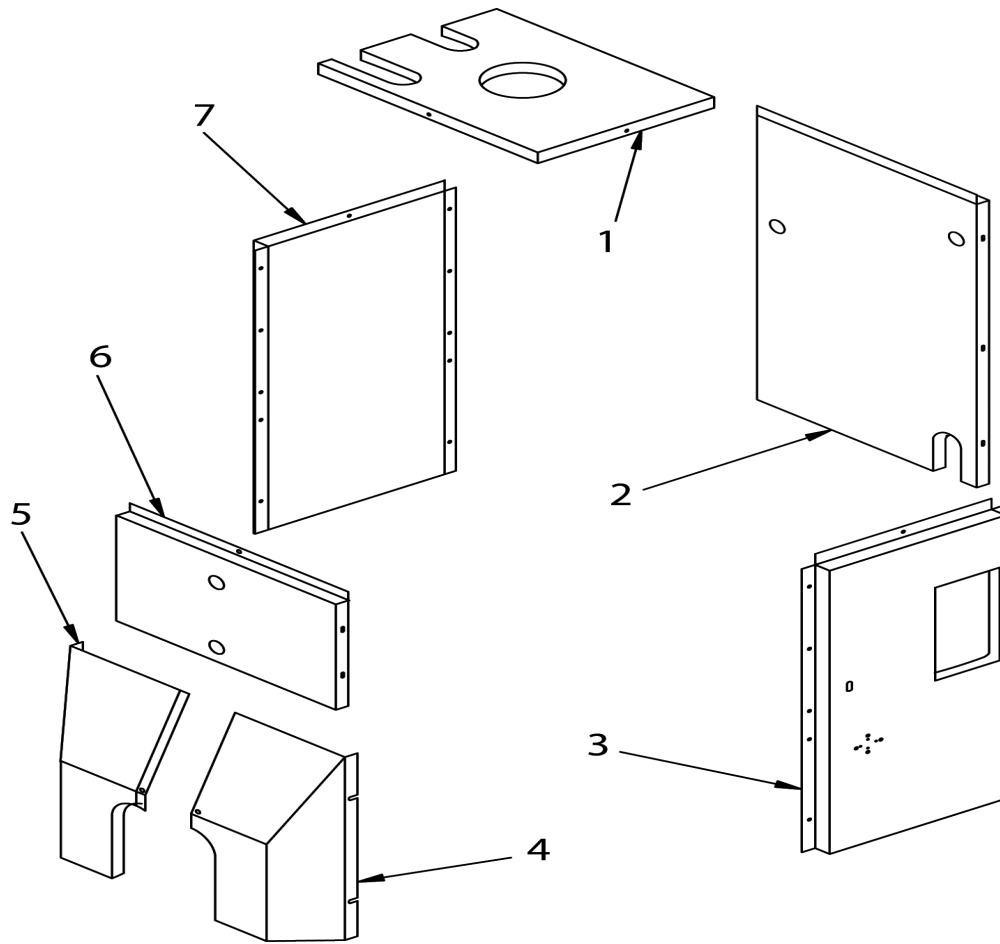

ITEM	DESCRIPTION	MODEL	MODEL	MODEL	MODEL
		ESC	KSC	SFE	CSFE
		PART #	PART #	PART #	PART #
1	TOP PANEL - 3 SEC.	21522801	21522808	21522801	21522801
	TOP PANEL - 4 SEC.	21522802	21522809	21522802	21522802
	TOP PANEL - 5 SEC.	21522803	21522810	21522803	21522803
	TOP PANEL - 6 SEC.	21522806	21522811	21522806	21522806
2	REAR PANEL	21525201	21525202	21525201	21525201
3	RIGHT SIDE PANEL - 3 SEC.	21523106	21523101	21523101	21523101
	RIGHT SIDE PANEL - 4 SEC.	21523107	21523102	21523102	21523102
	RIGHT SIDE PANEL - 5 SEC.	21523108	21523103	21523103	21523103
	RIGHT SIDE PANEL - 6 SEC.	21523109	21523104	21523104	21523104
4	LOWER COWL - RIGHT	21524401	21524402	21524401	21524401C
5	LOWER COWL - LEFT	21524301	21524302	21524301	21524301C
6	TOP FRONT PANEL	21524101	21524102	21524101	21524101
7	LEFT SIDE PANEL - 3 SEC.	21521808	21521803	21521803	21521803
	LEFT SIDE PANEL - 4 SEC.	21521809	21521804	21521804	21521804
	LEFT SIDE PANEL - 5 SEC.	21521810	21521805	21521805	21521805
	LEFT SIDE PANEL - 6 SEC.	21521811	21521806	21521806	21521806
Not Shown	*JACKET REPLACEMENT KIT - 3 SEC.	3001487AC	3001487AD	3001487AH	3001487C
	*JACKET REPLACEMENT KIT - 4 SEC.	3001488AC	3001488AD	3001488AH	3001488C
	*JACKET REPLACEMENT KIT - 5 SEC.	3001489AC	3001489AD	3001489AH	3001489C
	*JACKET REPLACEMENT KIT - 6 SEC.	3001490AC	3001490AD	3001490AH	3001490C

* Items 4 and 5 must be ordered to receive full jacket set

REPLACEMENT PARTS

HEAT EXCHANGER

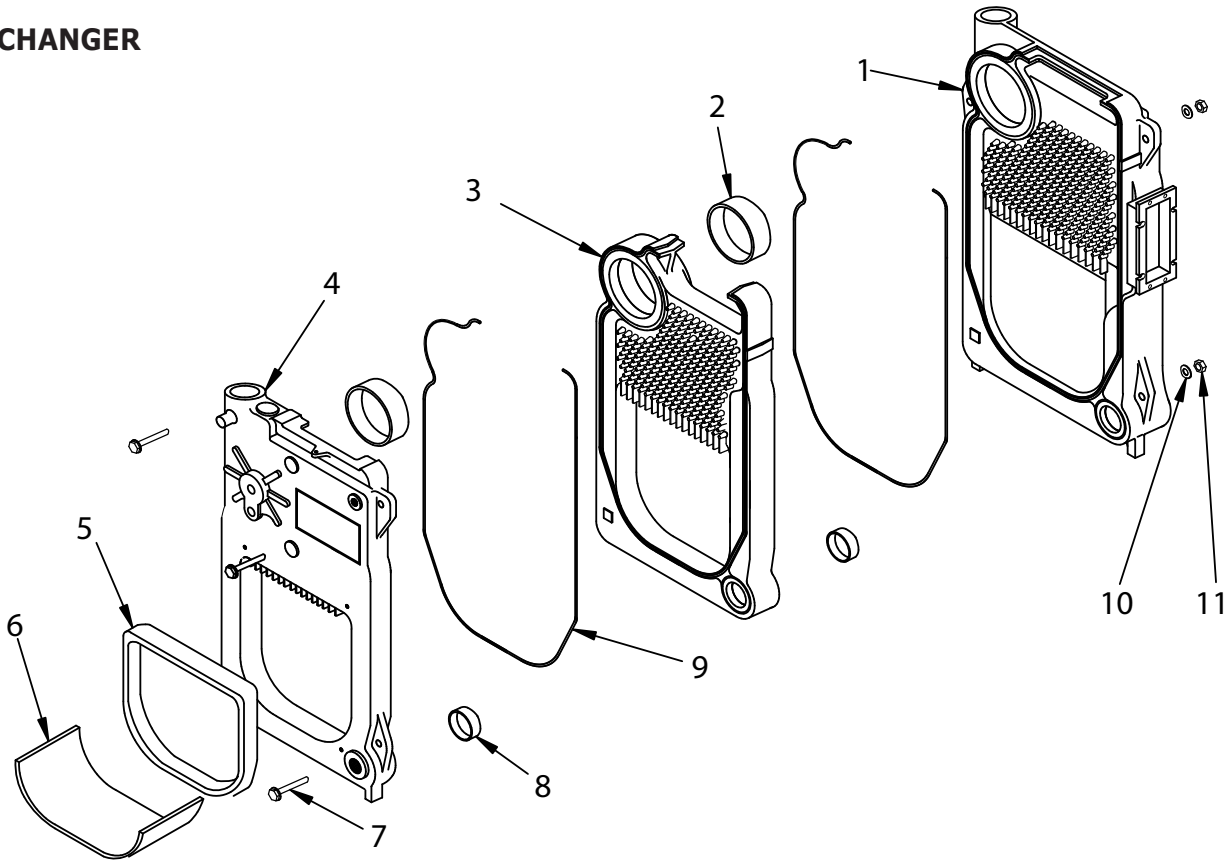

ITEM	PART NO.	DESCRIPTION	QTY
1	902000018	REAR SECTION	1
2	100-1-8.01	#60 PUSH NIPPLE - 3 SEC.	2
		#60 PUSH NIPPLE - 4 SEC.	3
		#60 PUSH NIPPLE - 5 SEC.	4
		#60 PUSH NIPPLE - 6 SEC.	5
		CENTER SECTION - 3 SEC.	1
3	902000009	CENTER SECTION - 4 SEC.	2
		CENTER SECTION - 5 SEC.	3
		CENTER SECTION - 6 SEC.	4
		FRONT SECTION CASTOVER	1
4	902000014	FRONT SECTION CASTOVER	1
5611508		KIT - TARGET WALL & INSULATION BLANKET	
Kit Includes #5 and #6			
5	2552701	TARGET WALL - PYROLITE	1
6	25511005	INSUL BLANKET 16X24	1
7	HW-025.05	TIE ROD ½ X 9 - 3 SEC.	3
	HW-025.01	TIE ROD ½ X 12½ - 4 SEC.	
	HW-025.02	TIE ROD ½ X 16½ - 5 SEC.	
	HW-025.03	TIE ROD ½ X 20½ - 6 SEC.	
8	100-1-5.01	#22 Push Nipple - 3 Sec.	2
		#22 Push Nipple - 4 Sec.	3
		#22 Push Nipple - 5 Sec.	4
9	3002172	Rope, Med. Density - 3 Sec.	2
		Rope, Med. Density - 4 Sec.	3
		Rope, Med. Density - 5 Sec.	4
		Rope, Med. Density - 6 Sec.	5
10	HW-008.03	Washer ½ ID Flat	3
11	HW-003.05	Nut ½ -13 Hex Head	3

INSULATION BLANKET SIZING		
FITS	PART NO.	SIZE
3 Sec	25511001	6-1/4 x 24
4 Sec	25511002	8-1/2 x 16
5 Sec	2551803	13 x 16
6 Sec	25511005	24 x 16

FULLY ASSEMBLED HEAT EXCHANGERS	
550003466	3 SECTION WITHOUT COIL
550003467	4 SECTION WITHOUT COIL
550003468	5 SECTION WITHOUT COIL
550003469	6 SECTION WITHOUT COIL
550003470	3 SECTION WITH TANKLESS COIL
550003471	4 SECTION WITH TANKLESS COIL
550003472	5 SECTION WITH TANKLESS COIL
550003473	6 SECTION WITH TANKLESS COIL

REPLACEMENT PARTS

HARDWARE

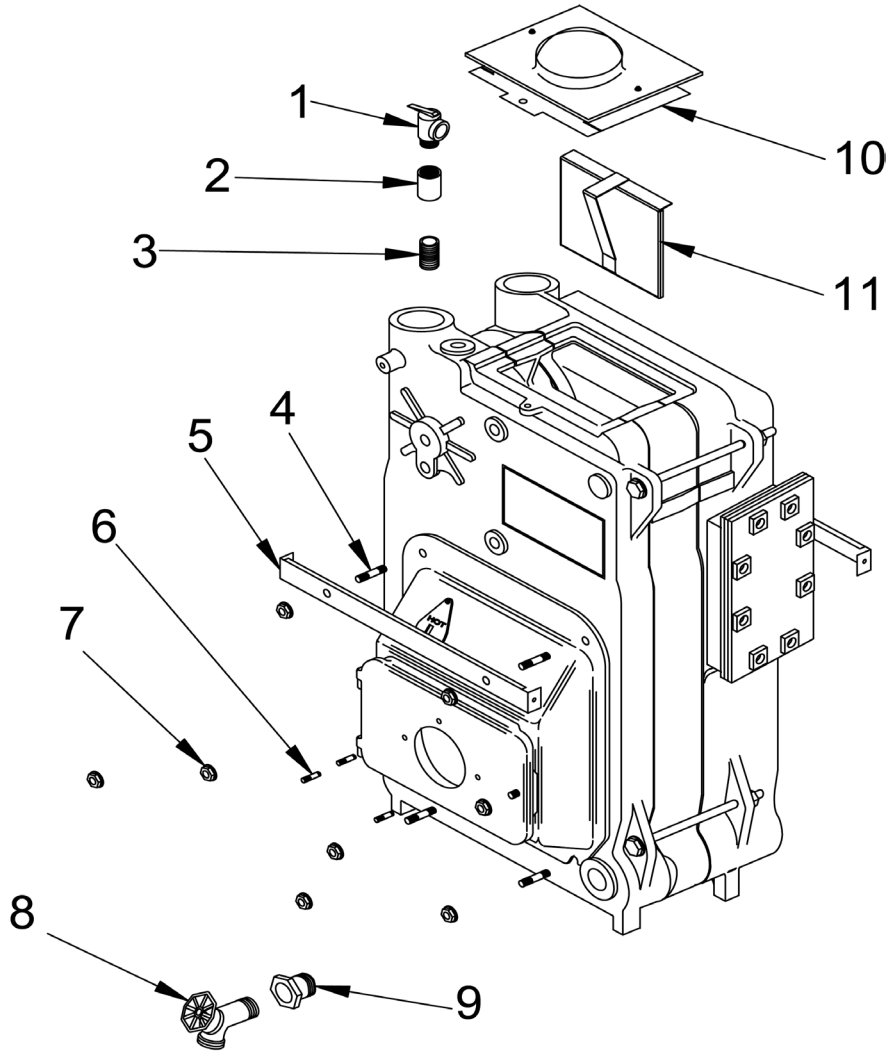

ITEM	PART NO.	DESCRIPTION	QTY
1	1570001	SAFETY VALVE #15 ¾"	1
2	1150001	PIPE FIT COUPLING ¾"	1
3	1310004	PIPE FIT NPL ¾" CLOSE	1
4	HW06701	STUD 5/16" - 18 X 2 3/8"	4
5	2252501	SUPPORT - JACKET BRKT	2
6	HW07001	STUD 5/16" X 18 X 1 3/8"	3
7	1330001	NUT 5/16" - 18 WISLOCK	8
8	240009323	DRAIN VALVE	1
9	1060003	PIPE FIT BUSHING 1¼ X ¾"	1
10	2452906	FLUE COLLECTOR - 3 SEC.	1
	2452902	FLUE COLLECTOR - 4 SEC.	
	2452903	FLUE COLLECTOR - 5 SEC.	
	2452907	FLUE COLLECTOR - 6 SEC.	
11	109007327	BAFFLE, ASSY, H/E, REAR	1

REPLACEMENT PARTS

SWING DOOR AND MOUNTING DOOR COMPONENTS

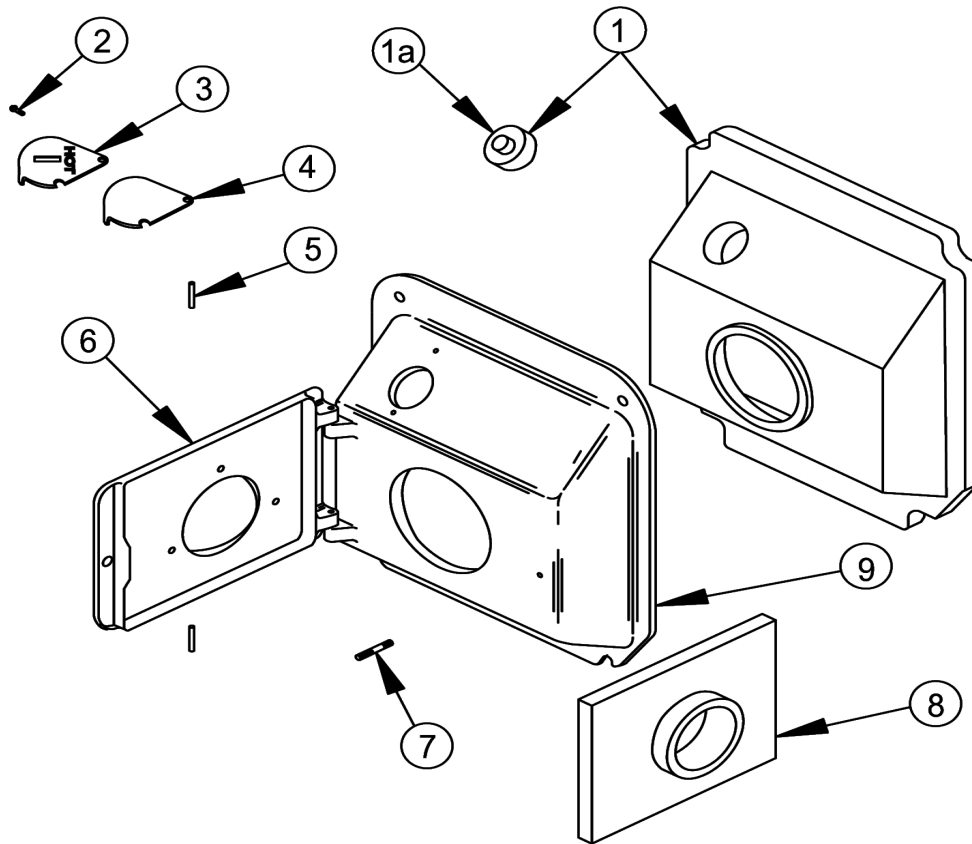

ITEM	PART NO.	DESCRIPTION	QTY
1	2552901	Mounting Door Insulation & Plug	1
1a	2551901	Door Plug Replacement	1
2	HW-005.01	Screw ¼ - 20 x ½ Self-Tapping	2
3	10011701	Observation Door	1
4	25511101	Obs. Door Gasket	1
5	HW06801	¼ x 1¾ Drive Lock Pin	2
6	10011501	Swing Door	1
7	HW06701	5/16 x 18 x 2 3/8 Stud	1
8	2553303	Insulation - Swing Door	1
9	10011301	Mounting Door	1
Not Shown	10011601	Cast Iron Mtg/Swing Dr Mach. Includes Item 2,3,4,5,6,7 & 9	1

REPLACEMENT PARTS

BURNER COMPONENTS

PART NO.	DESCRIPTION
240009823	BRNR,BECK,AFG 3090
240009929	BRNR,BECK,AFG 4125
240009930	BRNR,BECK,AFG 5185
240009931	BRNR,BECK,AFG 6210
1250002	BURNER OIL FLANGE GASKET #36153
CD-001.01	CAD CELL
240008816	CONTROL 7505B1500
14619244	Nozzle, 0.75-60°B 3090 Beckett
1320024	Nozzle, 1.10-60°B 4125 Beckett
1320001	Nozzle, 1.50-70°B 5185 Beckett
14619019	Nozzle, 1.75-70°B 6210 Beckett
RP03801	Blast Tube AFG
29688	Fuel Pump, 1 Stage, 140 PSI, AFG 2184404U
1050008	Motor 21805U
1050007	Ignitor/Transformer 51771U



2201 Dwyer Avenue, Utica, NY 13501

Tel. 800 253 7900

www.ecrinternational.com

All specifications subject to change without notice.

©2018 ECR International, Inc.