

Models
CHB/CCB

APPLICATION GUIDE

WALL MOUNTED
GAS BOILER

This manual has been prepared for use with the appropriate Installation, Operation and Maintenance Manual.
For use with CCB/CHB Boilers ONLY.

TABLE OF CONTENTS

Important Safety Information	3
CHB - Hydronic Piping - Quick Reference Chart -CHB Boiler.....	5
Single Boiler Primary/Secondary Series Loop Zoned Sys. W/ ZONE VALVES & Optional Indirect Tank (Fig. 1).....	6
Single Boiler Primary/Secondary Series Loop Zoned W/ ZONE PUMPS & Optional Indirect Tank (Fig. 2).....	7
Single Boiler Primary/Secondary Series Loop PUMPING and Optional Indirect Tank (Fig. 3).....	8
CHB - Wiring Diagrams.....	9
Boiler with Optional Supply System Pump Single Zone - No Indirect Tank (Fig. 4)	10
Boiler with Single Zone DHW Indirect Tank and Sensor (Fig. 5).....	10
Isolation Relay - Pump Circuit Using System Pump Connections (Fig. 6).....	11
Boiler Zoned System with Multiple ZONE VALVES <i>WITHOUT</i> Indirect Tank (Fig. 7)	13
Boiler Zoned System with Multiple ZONE VALVES <i>WITH</i> Indirect Tank (Fig. 8)	14
Boiler WITH MULTIPLE ZONE PUMPS <i>WITHOUT</i> Indirect Tank (DHW) (Fig. 9)	15
Boiler WITH MULTIPLE ZONE PUMPS <i>WITH</i> Indirect Tank (DHW) (Fig. 10)	17
Boiler WITH Secondary Zone Pumps and DHW Thermostat, with DHW Resistor Kit (Fig. 11)	18
CCB - Hydronic Piping - Quick Reference Chart	19
<u>BURN AND SCALD HAZARD! WARNING</u> Manufacturer Requires Installation Of Field Supplied Anti-Scald Valve....	20
Single Boiler Primary/Secondary Series Loop Zoned System WITH ZONE VALVES (Fig. 12)	21
Single Boiler Primary/Secondary Series Loop Zoned WITH ZONE PUMPS (Fig. 13)	22
Single Boiler Primary/Secondary Series Loop PUMPING (Fig. 14).....	23
CCB - Wiring Diagrams	24
Boiler with Optional Supply System Pump (Fig. 15)	24
Boiler with Multiple Zone Valves (Fig. 16)	25
Boiler with Multiple Zone Pumps WITHOUT DHW Interface (Fig. 17)	27
Boiler with Multiple Zone Pumps with DHW Interface (Fig. 18).....	28
Applications Tables For : CHB - With Indirect Hot Water Tank.....	29
Optional Equipment.....	31
Venting Options	31
Outdoor Air Sensor & NTC Sensor Data	32
Manufacturer Recommended Strainer.....	33
Low Water Cutoff.....	34
Addendum - Instructions.....	38
Domestic Hot Water Sensor Kit Instruction (240010745).....	39-42
Instructions And Wiring Diagram For Adding External Pump (615000137).....	43-44
Sealed Combustion Kit Instructions (37711601) - For Kit #5612601.....	45
Control Board Replacement Kit Instructions (615000134).....	46-47
Retaining Clip Removal Caution (615000136).....	48-49
Altitude Affects on CHB-100, CHB-130, CHB-150 and CCB-150.....	50
LP Conversion Kit Instructions.....	51-53
DHW Resistor Harness and Relay Kit (550003082).....	54-57

IMPORTANT SAFETY INFORMATION

1. General

Boiler installation shall be completed by qualified agency. See Installation, Operation & Maintenance Manual for additional information.

WARNING

Fire, explosion, asphyxiation and electrical shock hazard. Improper installation could result in death or serious injury. Read this manual and understand all requirements before beginning installation.

2. Become familiar with symbols identifying potential hazards.



This is the safety alert symbol. Symbol alerts you to potential personal injury hazards. Obey all safety messages following this symbol to avoid possible injury or death.

DANGER

Indicates a hazardous situation which, if not avoided, WILL result in death or serious injury.

WARNING

Indicates a hazardous situation which, if not avoided, could result in death or serious injury.

CAUTION

Indicates a hazardous situation which, if not avoided, could result in minor or moderate injury.

NOTICE

Used to address practices not related to personal injury.

3. Installation shall conform to requirements of authority having jurisdiction or in absence of such requirements:

- United States
 - National Fuel Gas Code, ANSI Z223.1/NFPA 54.
 - National Electrical Code, NFPA 70.
- Canada
 - Natural Gas and Propane Installation Code, CAN/CSA B149.1.
 - Canadian Electrical Code, Part I, Safety Standard for Electrical Installations, CSA C22.1

4. Where required by authority having jurisdiction, installation shall conform to Standard for Controls and Safety Devices for Automatically Fired Boilers, ANSI/ASME CSD-1.

Additional manual reset low water cutoff may be required.

5. Requirements for Commonwealth of Massachusetts:

Boiler installation must conform to Commonwealth of Massachusetts code 248 CMR which includes but is not limited to:

- Installation by licensed plumber or gas fitter.

HYDRONIC PIPING CONNECTIONS

HEATING ONLY

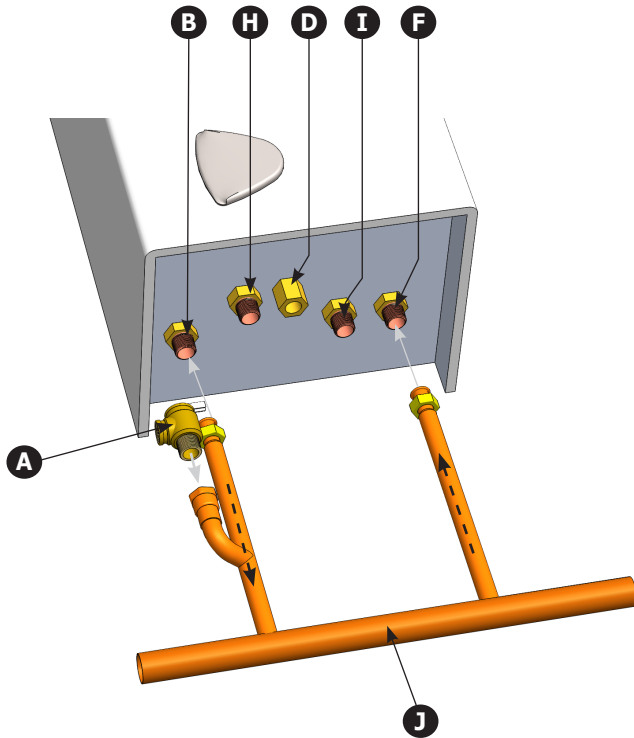

COMBI

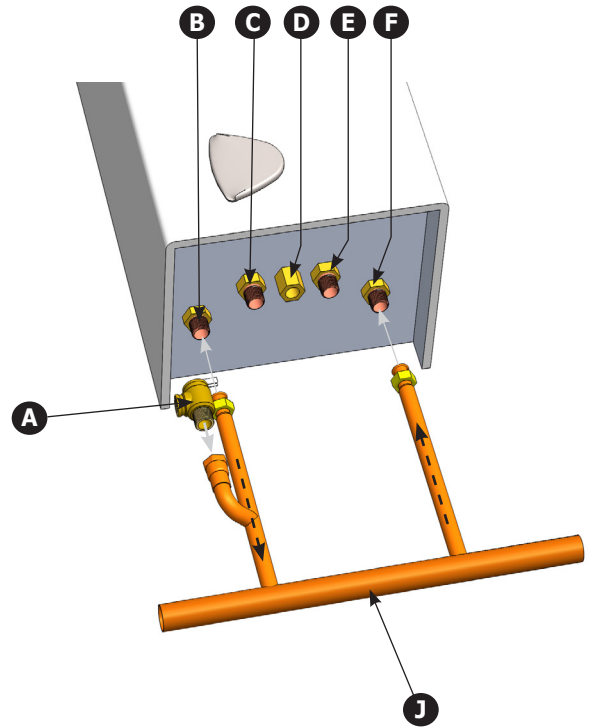

A	Pressure Relief Valve	30 psi [2.11 bar]
B	Central Heating Supply Connection	3/4" [22.2mm]
C	DHW outlet Combi Boiler	3/4" [22.2mm]
D	Gas Connection	3/4" [22.2mm]
E	Cold DHW Inlet	3/4" [22.2mm]
F	Central Heating Return connection	3/4" [22.2mm]
H	Optional Indirect DHW Supply Connection (Capped)	3/4" [22.2mm]
I	Optional Indirect DHW Return Connection (Capped)	3/4" [22.2mm]
J	Manifold	-

NOTICE

Manufacturer recommends installation of Pressure Relief Valve to Manifold before connecting manifold to boiler.

CHB - HYDRONIC PIPING

NOTICE

Illustrations are meant to show system piping concept only. Installer is responsible for all equipment and detailing required by authority having jurisdiction.

NOTICE

Arrange piping to prevent water dripping onto boiler.

Piping installation, materials, and joining methods shall conform to requirements of authority having jurisdiction or in absence of such requirements:

- USA - National Fuel Gas Code, ANSI Z223.1/NFPA 54
- Canada - Natural Gas and Propane Installation Code, CAN/CSA B149.1

Manufacturer requires all domestic hot water (DHW) installations use an anti-scald valve. Local codes may require additional equipment (expansion tank, relief valves, etc.) select and size equipment to suit installation and meet code requirements.

CHB - Piping Legend

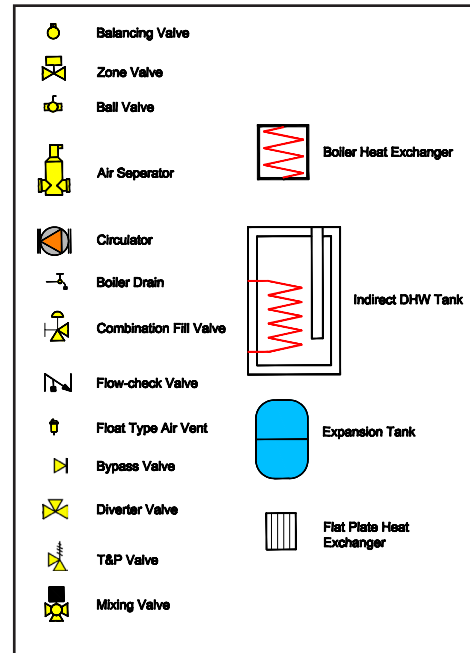

Quick Reference Chart - CHB Boiler

CHB - Hydronic Piping Description	Page
Single Boiler Primary/Secondary Series Loop Zoned System With Zone Valves and Optional Indirect Tank (Fig. 1)	6
Single Boiler Primary/Secondary Series Loop Zoned With Zone Pumps and Optional Indirect Tank (Fig. 2)	7
Single Boiler Primary/Secondary Series Loop PUMPING and Optional Indirect Tank (Fig. 3)	8
CHB - Wiring Description	Page
Single Zone, WITHOUT DHW Tank, with optional Supply System Pump (Fig. 4)	10
Boiler with DHW Tank/Sensor, with Optional System Supply Pump (Fig. 5)	10
System Supply Pump Connections (Key 307) using Isolation Relay (Fig. 6)	11
Multiple Zone Valves, WITHOUT Indirect Tank (CH only) (Fig. 7)	13
Multiple Zone Valves, WITH Indirect Tank/ Sensor (Fig. 8)	14
Multiple Zone Pumps, WITHOUT Indirect Tank (CH only) (Fig. 9)	16
Multiple Zone Pumps, WITH Indirect/Sensor (Fig. 10)	17
Multiple Zone Pumps, WITH Indirect Tank/Mechanical Thermostat/Isolation Relay (Fig. 11)	18
Application Tables For : CHB - With Indirect Hot Water Tank	29

CHB - HYDRONIC PIPING

FIGURE 1 - CHB - Single Boiler Primary/Secondary Series Loop Zoned System WITH ZONE VALVES and Optional Indirect Tank

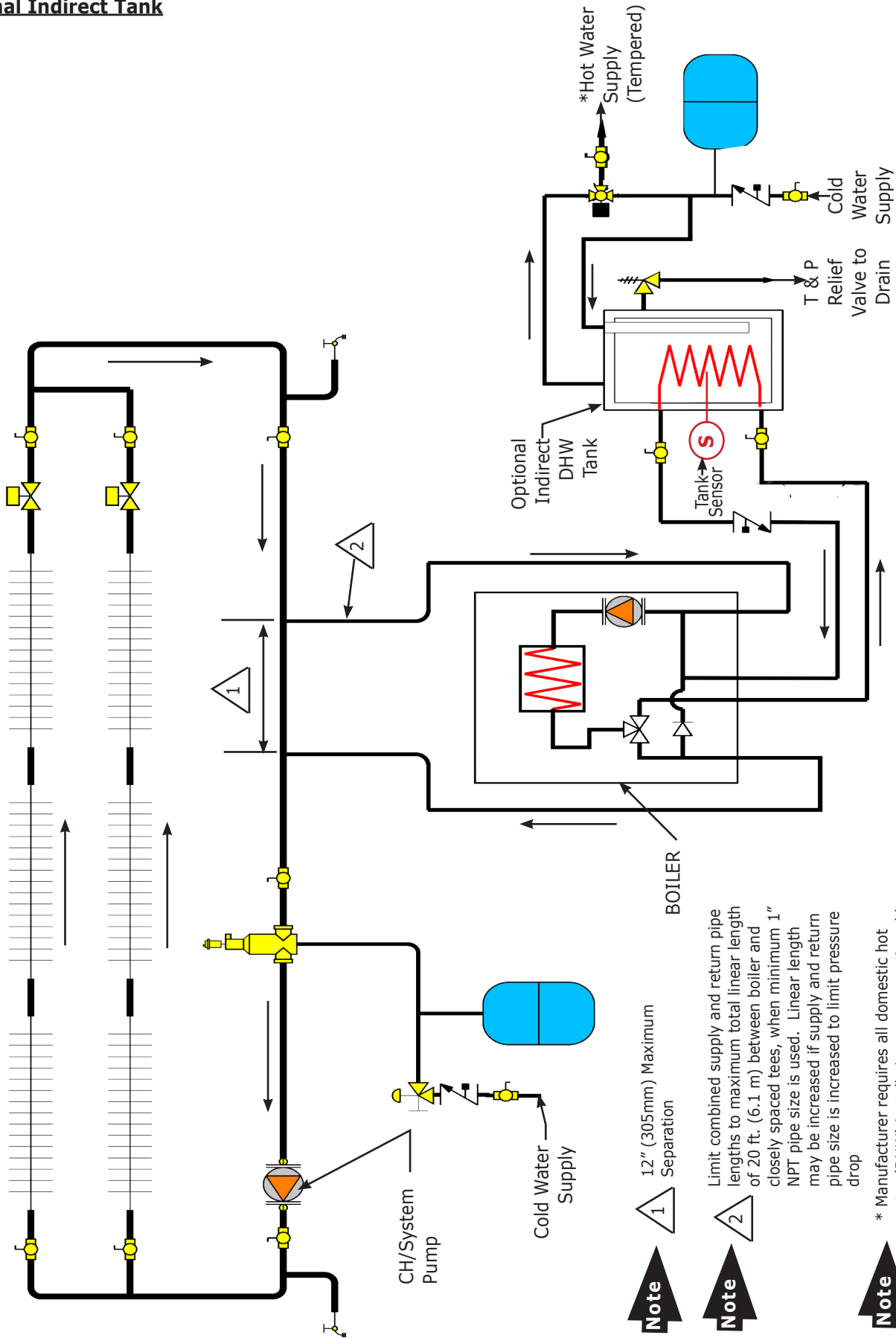

Note 1 12" (305mm) Maximum Separation

Note 2 Limit combined supply and return pipe lengths to maximum total linear length of 20 ft. (6.1 m) between boiler and closely spaced tees, when minimum 1" NPT pipe size is used. Linear length may be increased if supply and return pipe size is increased to limit pressure drop

Note * Manufacturer requires all domestic hot water (DHW) installations use an anti-scald valve. Local codes may require additional equipment (expansion tank, relief valves, etc.) Select and size equipment to suit installation and meet code requirements.

For indirect tank applications using boiler's on-board pump refer to Applications Tables for flow rate and available pump head. Consult indirect tank manufacturer for indirect tank performance.

CHB - HYDRONIC PIPING

FIGURE 2 - CHB -Single Boiler Primary/Secondary Series Loop Zoned WITH ZONE PUMPS and Optional Indirect Tank

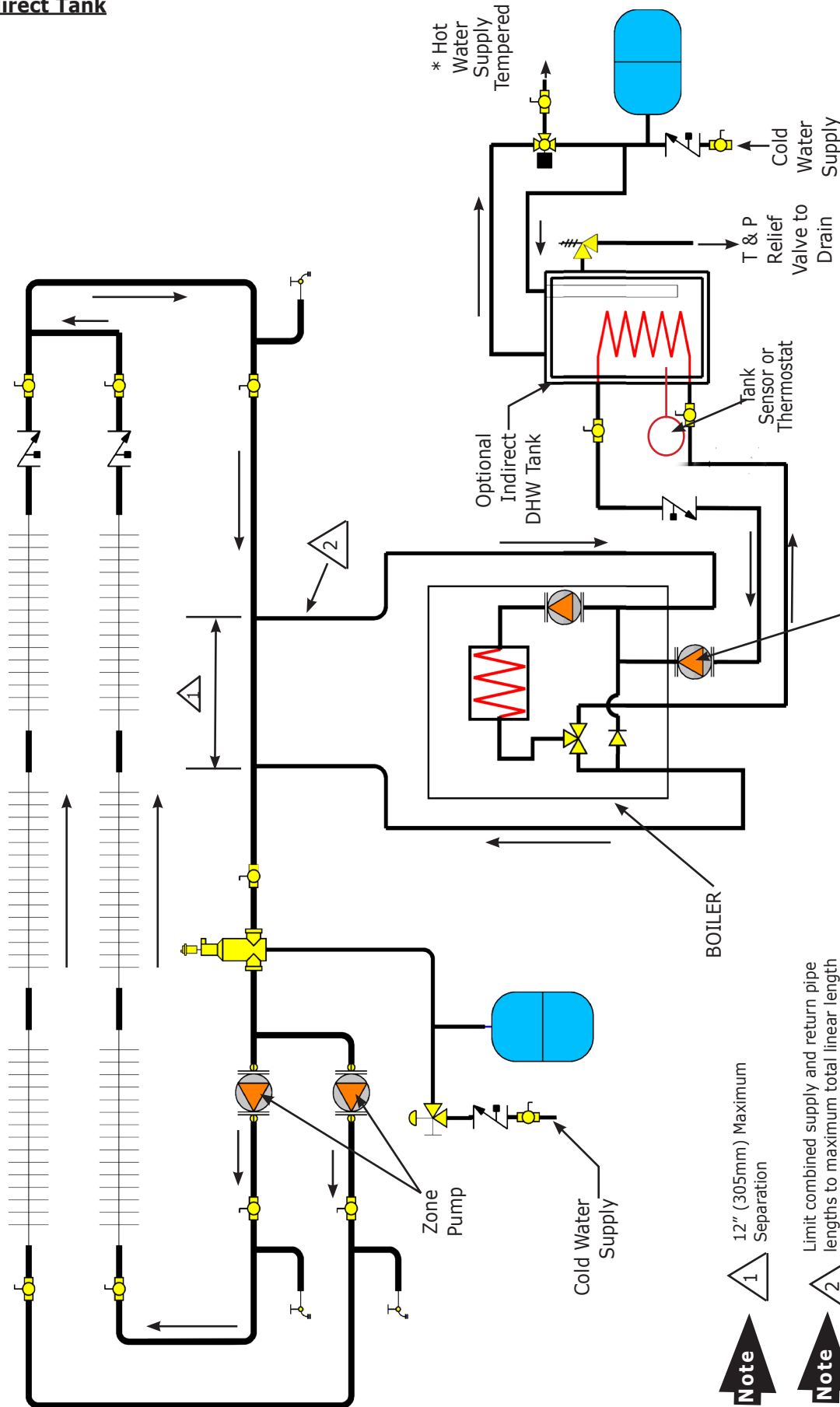

Optional Indirect Tank
 Optional Priority Zone 1 Pump (if needed) See Wiring Figure 11

Note 1 12" (305mm) Maximum Separation

Note 2 Limit combined supply and return pipe lengths to maximum total linear length of 20 ft. (6.1 m) between boiler and closely spaced tees, when minimum 1" NPT pipe size is used. Linear length may be increased if supply and return pipe size is increased to limit pressure drop

Note * Manufacturer requires all domestic hot water (DHW) installations use an anti-scald valve. Local codes may require additional equipment (expansion tank, relief valves, etc.) Select and size equipment to suit installation and meet code requirements.

For indirect tank applications using boiler's on-board pump refer to Applications Tables for flow rate and available pump head. Consult indirect tank manufacturer for indirect tank performance.

FIGURE 3 - CHB -Single Boiler Primary/Secondary Series Loop PUMPING and Optional Indirect Tank

* Manufacturer requires all domestic hot water (DHW) installations use an anti-scald valve. Local codes may require additional equipment (expansion tank, relief valves, etc.) Select and size equipment to suit installation and meet code requirements.

Note

For indirect tank applications using boiler's on-board pump refer to Applications Tables for flow rate and available pump head. Consult indirect tank manufacturer for indirect tank performance.

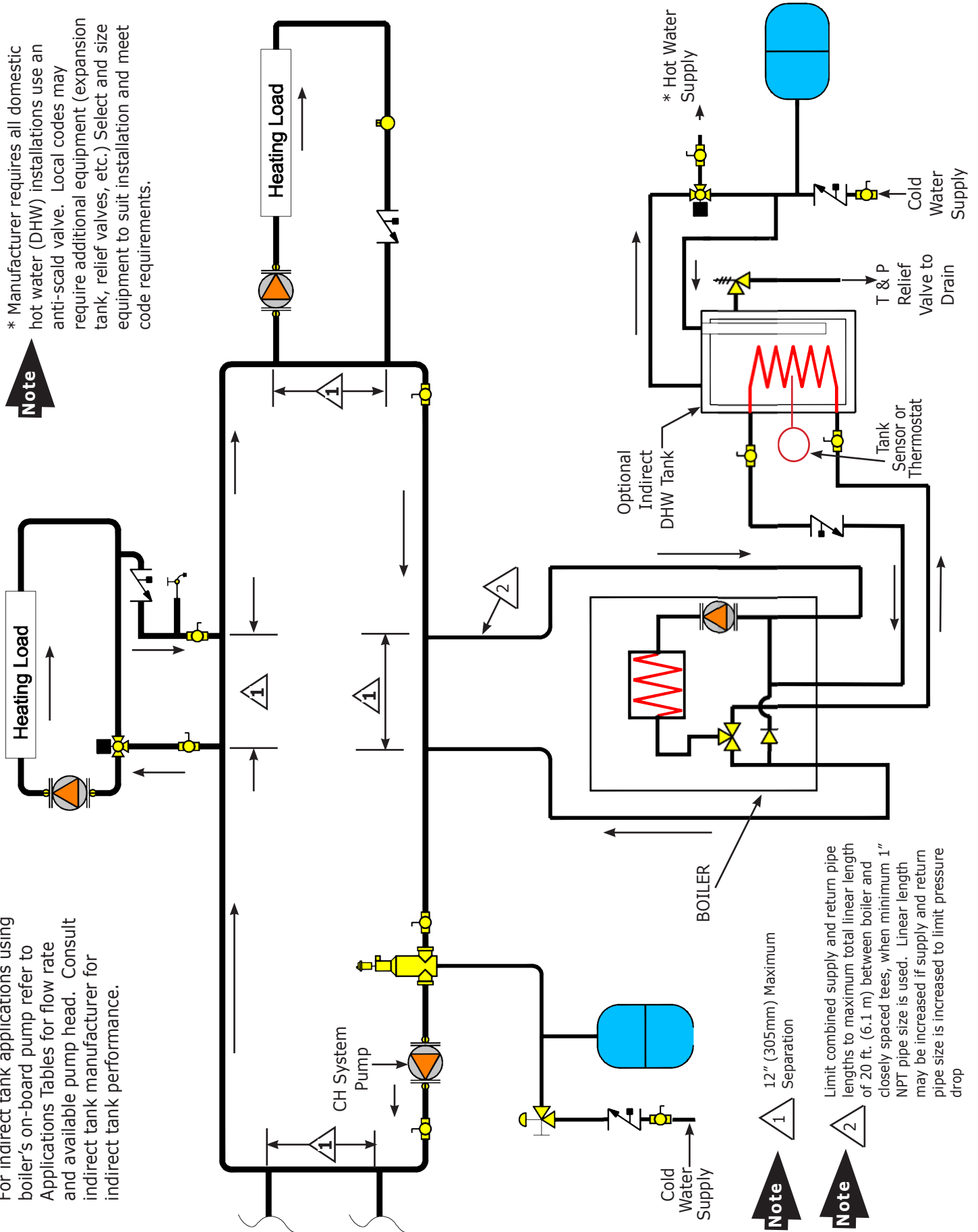

Note 12" (305mm) Maximum Separation

Note Limit combined supply and return pipe lengths to maximum total linear length of 20 ft. (6.1 m) between boiler and closely spaced tees, when minimum 1" NPT pipe size is used. Linear length may be increased if supply and return pipe size is increased to limit pressure drop

CHB Boiler Wiring Diagrams

All field wiring shall conform to the authority having jurisdiction or, in the absence of such requirements to:

- USA:** National Electrical Code, ANSI/NFPA 70,
- Canada:** Canadian Electrical Code, Part I, CSA
C22.1: Safety Standard for Electrical Installations.

A. CHB Single Zone Indirect Storage Tank is NOT used:

- Terminals 7 and 8 (Key 155) on CHB terminal strip, shall have two (2) factory supplied resistors wired in parallel.
- Single room thermostat (Key 72) control internal pump and boiler operation. Remove jumper when connecting thermostat or zone equipment.
- See Wiring Figure 4.

B. When System Supply Pump is needed:

- External supply system pump connection terminals (Key 307) are being added to the rear of the control box and will be limited to an additional 1 Amp pump operation. Internal control fusing will prevent higher pump operation.
- If control **IS NOT** equipped with these terminals, or larger pump capacity is required. Install an external pump/relay controller circuit. See Instructions and wiring diagram for adding external pump (615000137) provided with this manual.
- If control **IS** equipped with (Key 307) contacts and larger than 1 Amp circulating pump is required, use an isolation relay 120 VAC and separate 120 VAC power supply. See wiring Figure 6. Manufacture recommends use of isolation relay (240011284) or equivalent.

C. Use of Indirect Storage Tank (DHW)/ Single Zone :

Terminals 7 and 8 (#155 in Key) resistors are removed. Attach Indirect Tank Sensor element to terminals #7 and #8 (Key 155) on CHB terminal strip. See Figure 5.

NOTICE

Important:

- Before connecting the room thermostat, remove jumper on terminal block. (Key 72)
- Before connecting optional Indirect Tank Sensor, remove two (2) resistors. (Key 155)
- Before connecting Low Water Cutoff remove jumper on terminal block. (Key 370)

Wiring Legend CHB/CCB

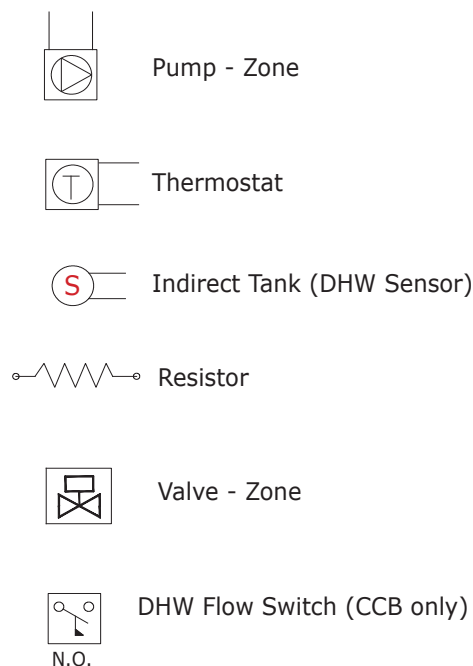

CHB - WIRING DIAGRAMS

FIGURE 4 - CHB Boiler with Optional Supply System Pump Single Zone - No Indirect Tank (DHW)

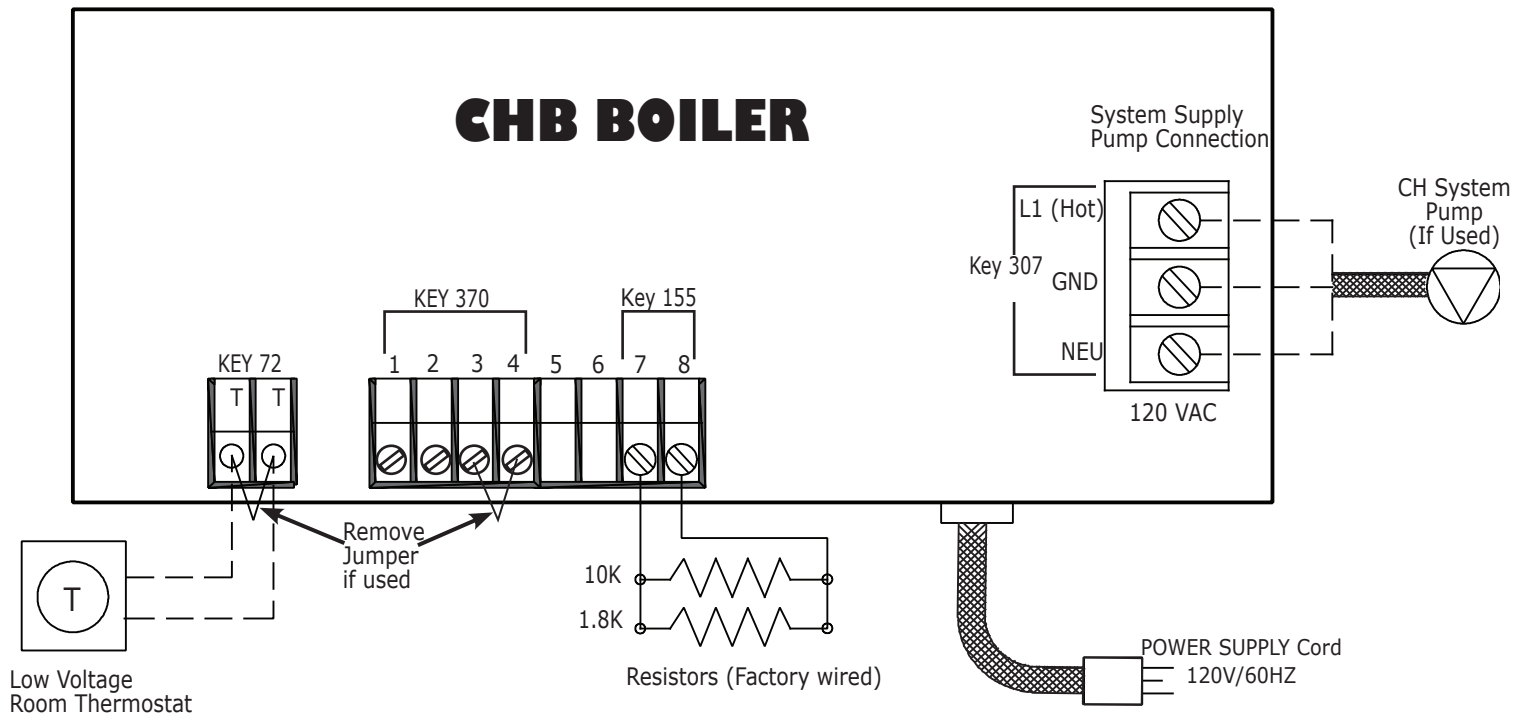
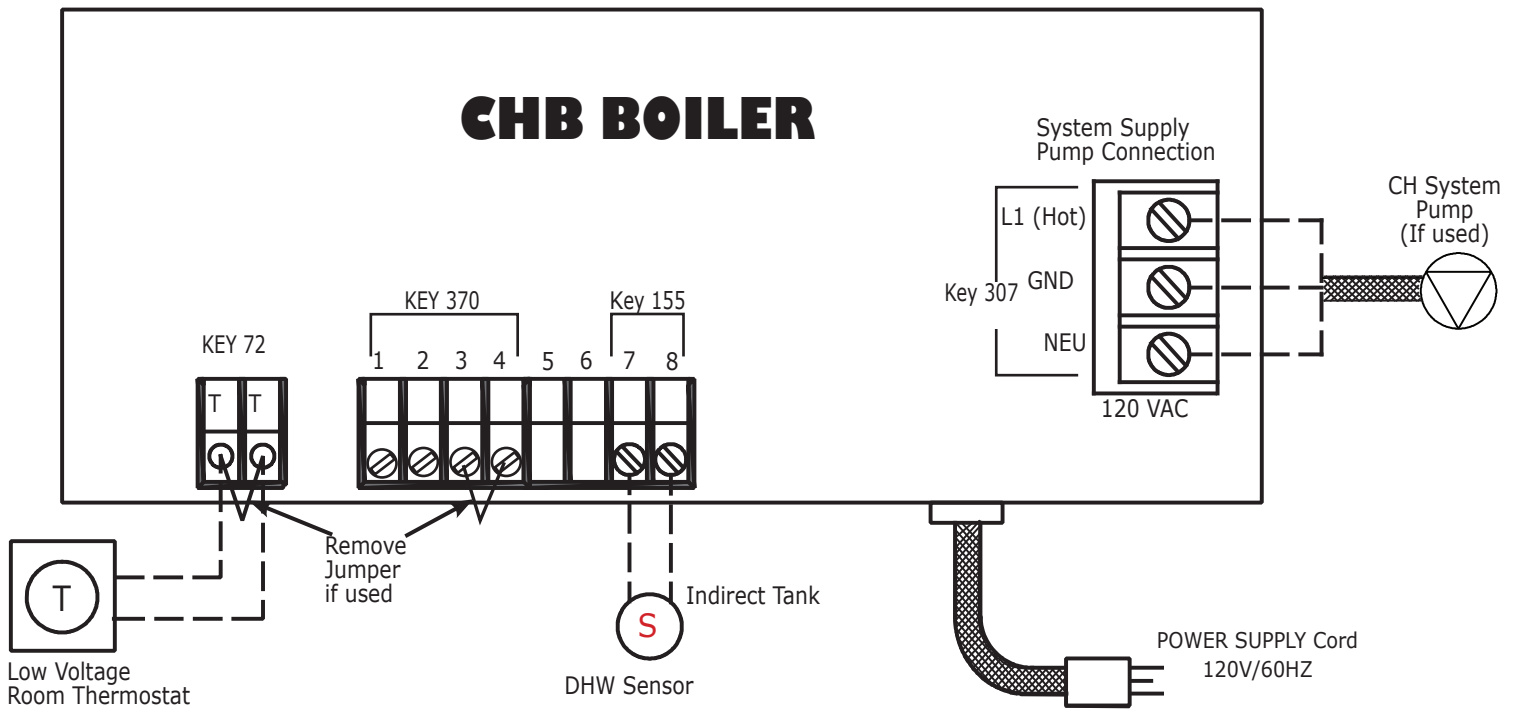

FIGURE 5 - CHB Boiler Single Zone with DHW Indirect Tank and Sensor



Remove two (2) factory installed Resistors when using Indirect Tank Sensor on Key 155. [Use kit 550002958]

CHB/CCB - WIRING DIAGRAM

FIGURE 6 - Isolation Relay - Pump Circuit Using System Pump Connections

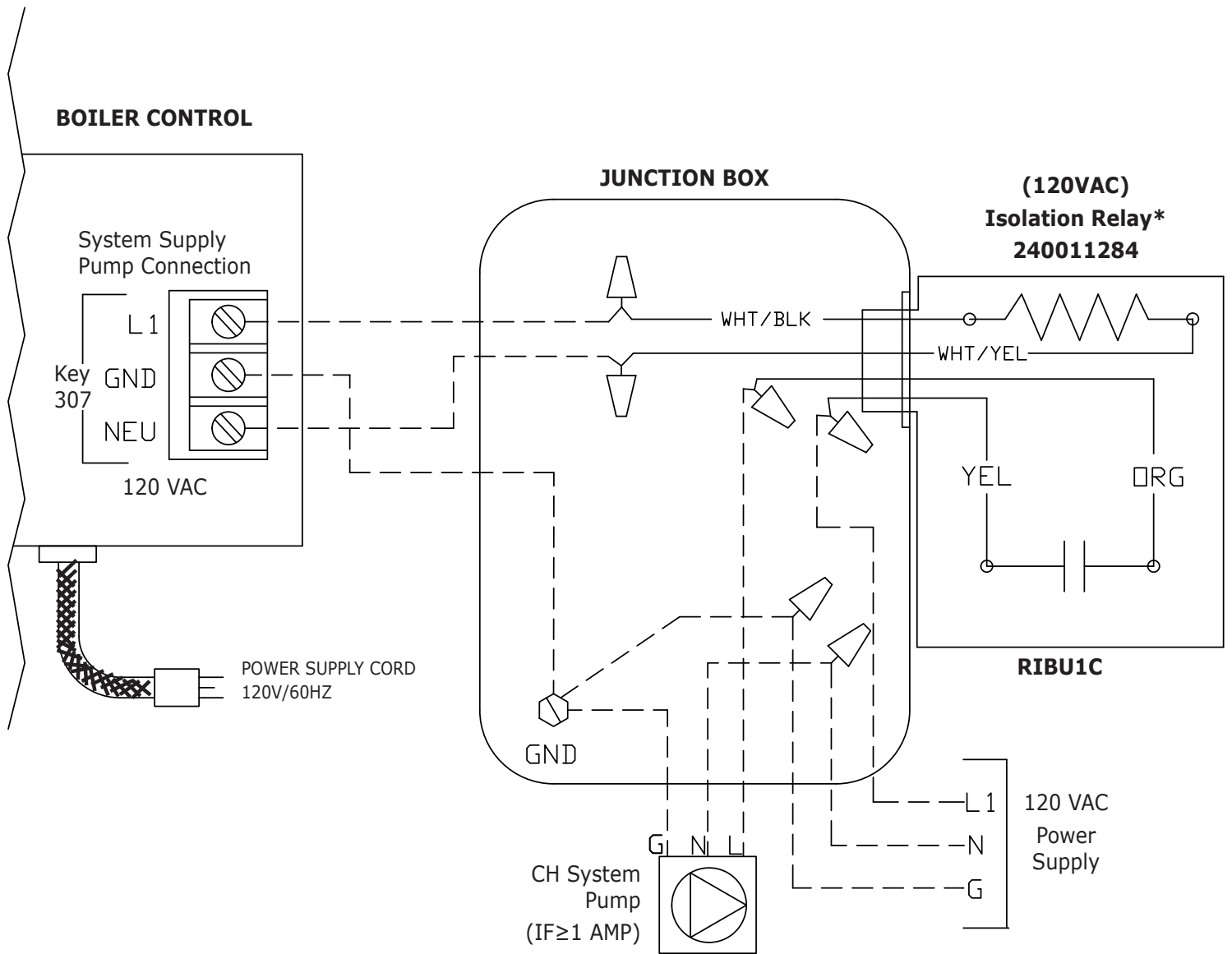

Note If larger than 1 amp system supply pump is required, use an isolation relay 120 VAC and separate 120 VAC power supply. Manufacturer requires use of isolation relay (240011284) or equivalent.

Note Wire nut unused wiring; Relay coil (24 V) - WHT/BLU; Relay contact (N.C.) - Blue, to prevent shorting.

D. Multi-Zoned Valve System:

1. If only Central Heating is required on multi-zone valve application - use factory supplied resistors on Key 155 terminal strip:
 - Boiler call for heat contacts (key 72) are wired to Argo Zone control X-X terminals.
 - Zone thermostats and valves are wired to Argo Control.
 - See wiring Figure 7.
2. If DHW tank is applied to Multi-Zone Valve application - use Indirect Tank Sensor:
 - Attach sensor to boiler control (Key 155) terminals 7 & 8. Boiler control will set priority for DHW operation.
 - Boiler call for heat contacts (Key 72) are wired to Argo Zone control X-X Terminals.
 - Zone thermostats and valves are wired to Argo Control.
 - See wiring Figure 8.

NOTICE

Important:

- Before connecting to Key 72 terminals, remove jumper on terminal block. (Key 72)
- Before connecting optional Indirect Tank Sensor, remove two (2) resistors. (Key 155)
- Before connecting Low Water Cutoff remove jumper on terminal block. (Key 370)

NOTICE

Set Argo Priority switch to OFF position.

CHB - WIRING DIAGRAM

FIGURE 7 - CHB - Boiler Zoned System with Multiple ZONE VALVES *WITHOUT* Indirect Tank

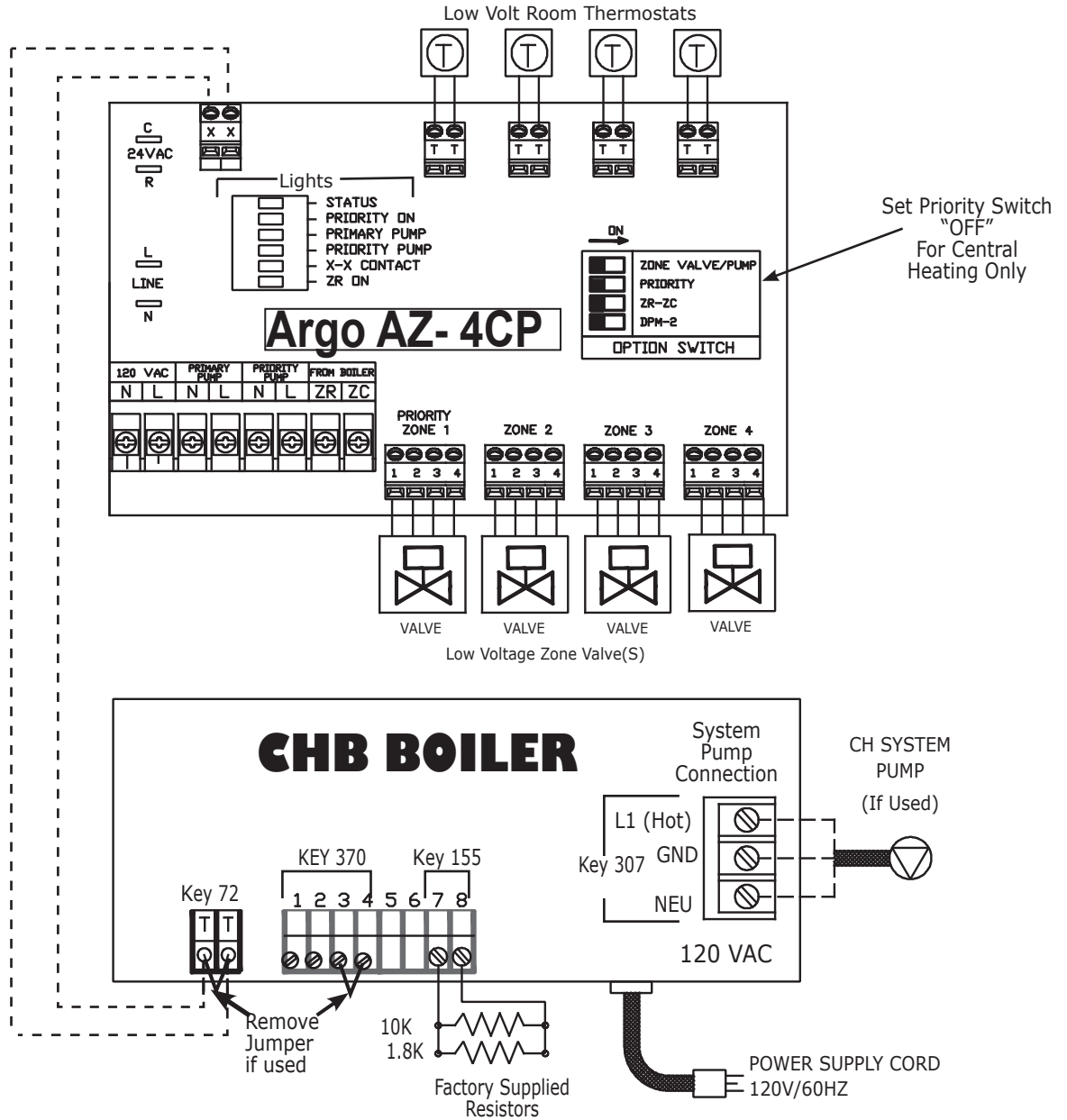

CHB - WIRING DIAGRAM

FIGURE 8 - CHB - Boiler Zoned System with Multiple ZONE VALVES WITH Indirect Tank

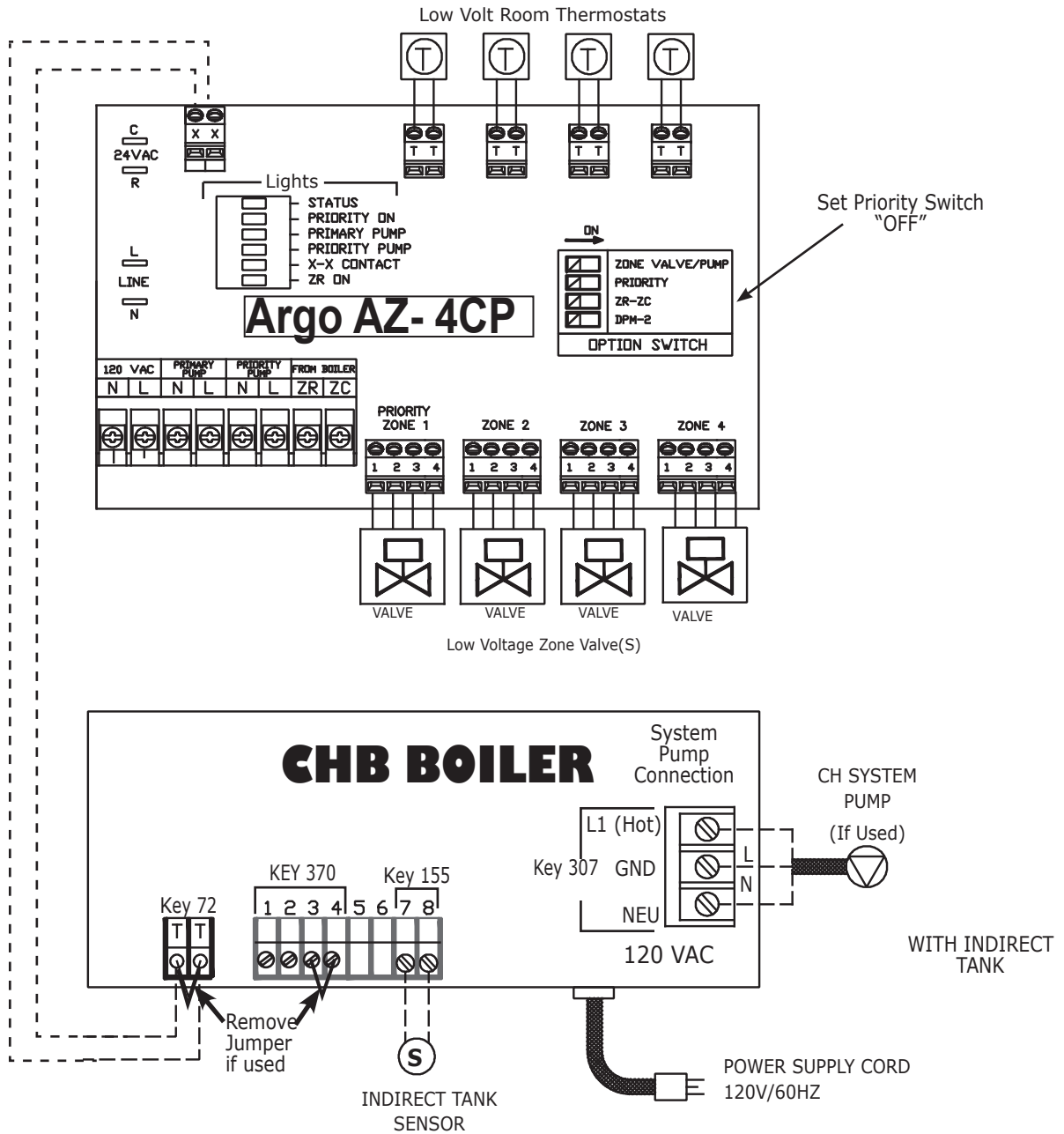

Remove two (2) factory installed resistors when using Indirect Tank Sensor on Key 155. [Use kit 550002958]

E. Multi-Zone Pump System Using Argo ARM Controller:

1 - If Indirect Storage Tank **IS NOT** applied to a multi-zoned piping system:

- Boiler thermostat contacts (Key 72) are wired to Argo ARM Zone Pump Control Terminals (X-X)
- Zone thermostats and zone pumps are wired to ARGO Controller
- Priority Switch OFF
- CH Heating only
- See Wiring Figure 9

2 - If Indirect Storage Tank **IS** applied to multi-zoned pump piping assembly:

- A. Tank sensing element is applied to boiler terminal strip 7 & 8 (Key 155).
 - Set Argo priority switch "OFF" if Zone 1 Priority **IS NOT** used.
Set Argo priority switch "ON" if Zone 1 Priority **IS** used.
 - See wiring Figure 10
 - DHW circuit is controlled by boiler control and is Priority heat demand.
- B. Storage tank mechanical thermostat is wired across zone 1 Priority contacts of Argo Control (Tw/Tr).
 - Apply Resistor Kit (550003082). Resistor Kit includes resistor wire harness and isolation relay (24 Vac).
 - Set Argo priority switch ON - DO NOT operate in "OFF" position.
 - See wiring Figure 11
 - DHW circuit is Priority heat demand and is controlled by Argo ARM Zone Control.

NOTICE

Important:

- Before connecting to Key 72 Terminals, remove jumper on terminal block.
- Before connecting Low Water Cutoff remove jumper on terminal block. (Key 370)

CHB - WIRING DIAGRAM

FIGURE 9 - CHB Boiler WITH MULTIPLE ZONE PUMPS *WITHOUT* Indirect Tank (DHW)

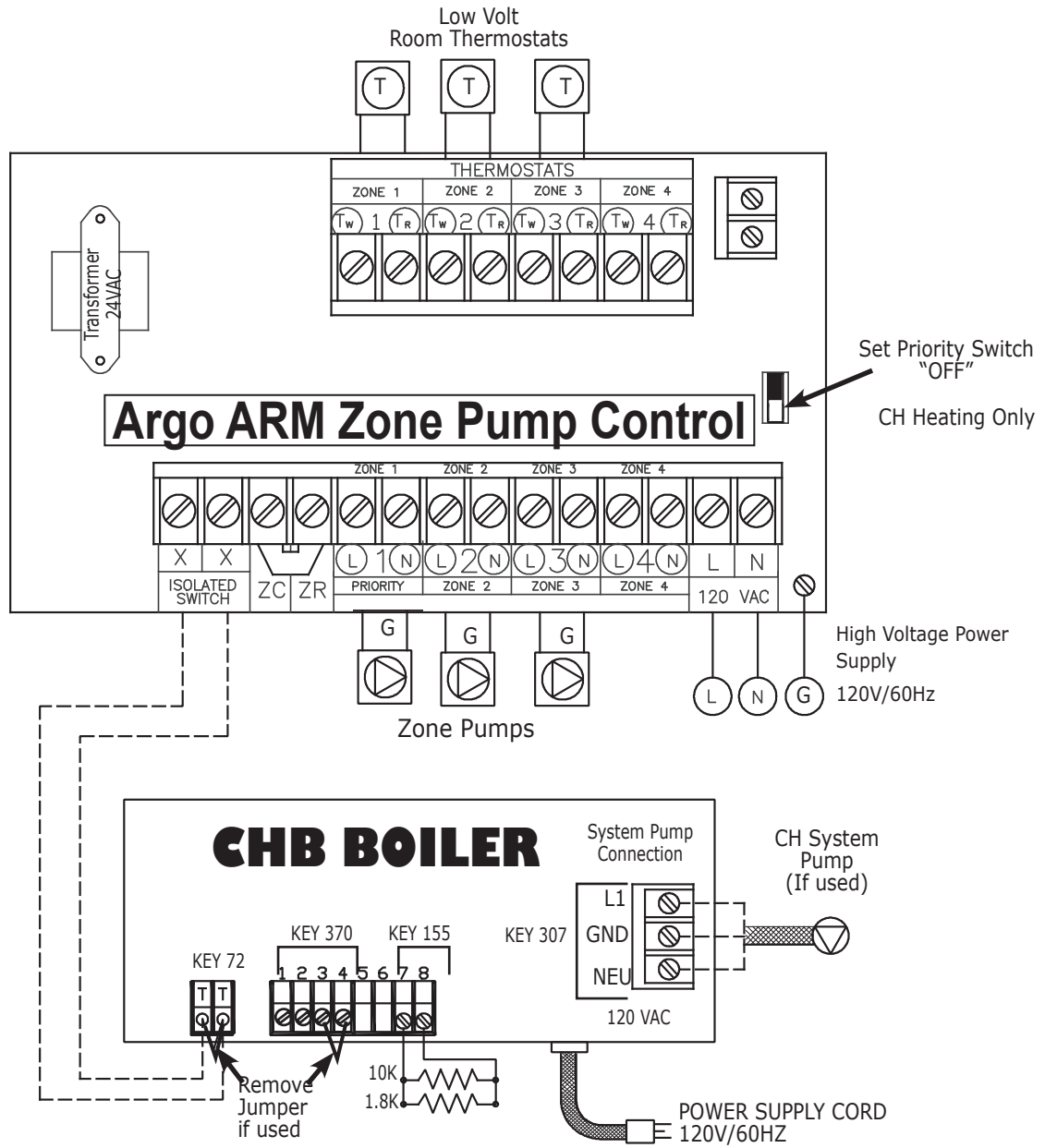

CHB - WIRING DIAGRAM

FIGURE 10 - CHB Boiler WITH MULTIPLE ZONE PUMPS WITH Indirect Tank (DHW)

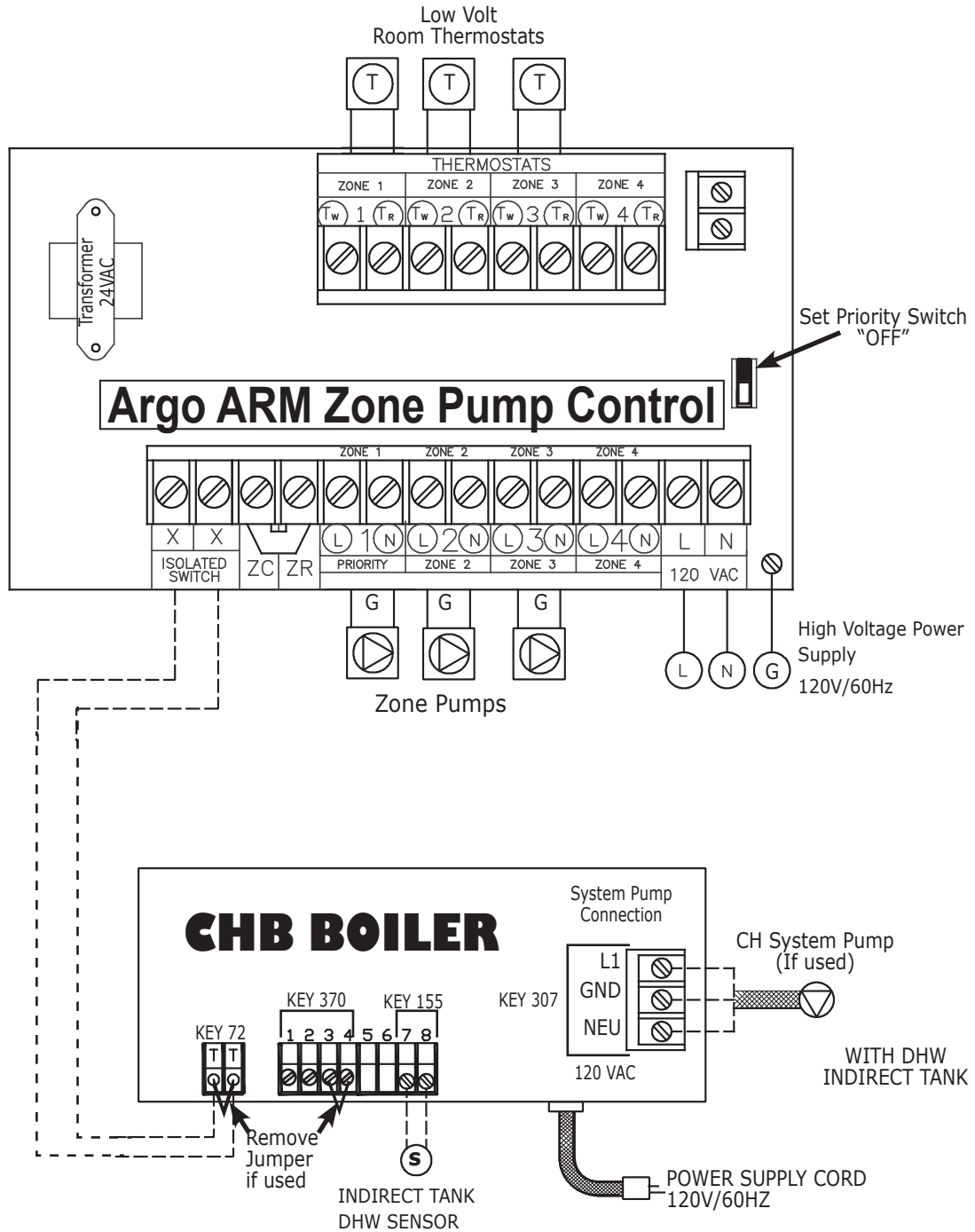

CHB - WIRING DIAGRAM

NOTICE

Important:

- Before connecting to Argo Control remove jumper on terminal block. (Key 72)
- Before connecting Low Water Cutoff remove jumper on terminal block. (Key 370)

FIGURE 11 - CHB Boiler WITH SECONDARY ZONE PUMPS AND DHW THERMOSTAT, WITH DHW RESISTOR KIT

NOTE: ZONE PUMPS WILL SHUTOFF DURING DHW PRIORITY W/ PRIORITY SWITCH ON

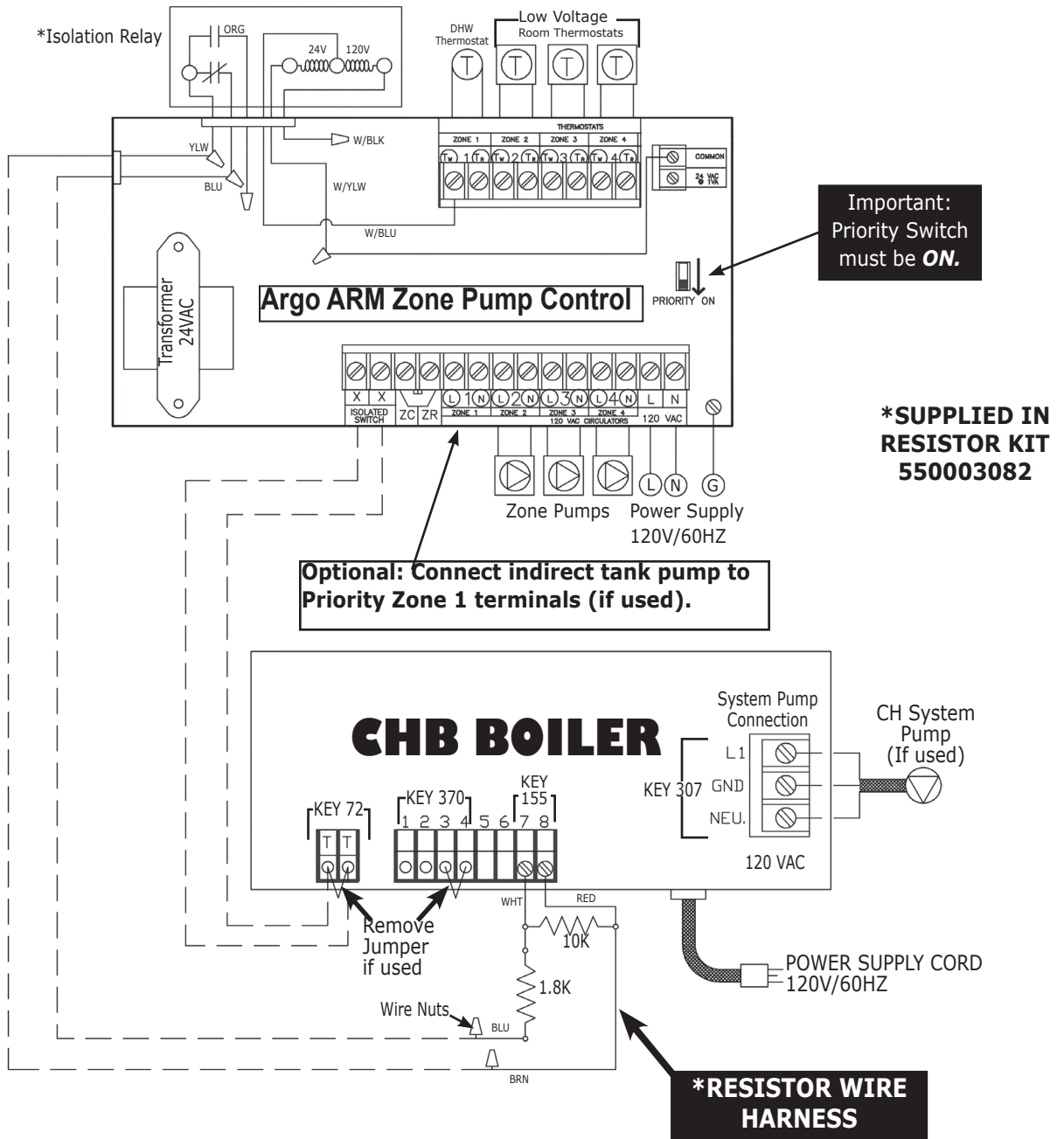

CCB - HYDRONIC PIPING

NOTICE

Arrange piping to prevent water dripping onto boiler.

A. Piping installation, materials, and joining methods shall conform to requirements of authority having jurisdiction or in absence of such requirements:

- USA - National Fuel Gas Code, ANSI Z223.1/NFPA 54
- Canada - Natural Gas and Propane Installation Code, CAN/CSA B149.1

B. Manufacturer requires all domestic hot water (DHW) installations use an anti-scald valve. Local codes may require additional equipment (expansion tank, relief valves, etc.) select and size equipment to suit installation and meet code requirements.

NOTICE

Illustrations are meant to show system piping concept only. Installer is responsible for all equipment and detailing required by authority having jurisdiction.

Quick Reference Chart - CCB Boiler

Quick Reference Chart - CCB Boiler	
CCB - Hydronic Piping Description	Page
ANTI-SCALD WARNING AND PIPING RECOMMENDATION	19
Single Boiler Primary/Secondary Series Loop Zoned System WITH ZONE VALVES (fig. 12)	20
Single Boiler Primary/Secondary Series Loop Zoned WITH ZONE PUMPS (fig. 13)	21
Single Boiler Primary/Secondary Series Loop PUMPING (fig. 14)	22
CCB - Wiring Description	
Boiler with Optional System Supply Pump (fig. 15)	23
Boiler with Multiple Zone Valves (fig. 16)	24
Boiler with Multiple Zone Pumps WITHOUT DHW Interface (fig. 17)	26
Boiler with Multiple Zone Pumps with DHW Interface (fig. 18)	27



WARNING

Burn and scald hazard!
 Manufacturer requires installation
 of field supplied anti-scald valve.
 Failure to follow these instructions could
 result in death or serious injury.

CCB-150 DHW ANTI-SCALD PIPING

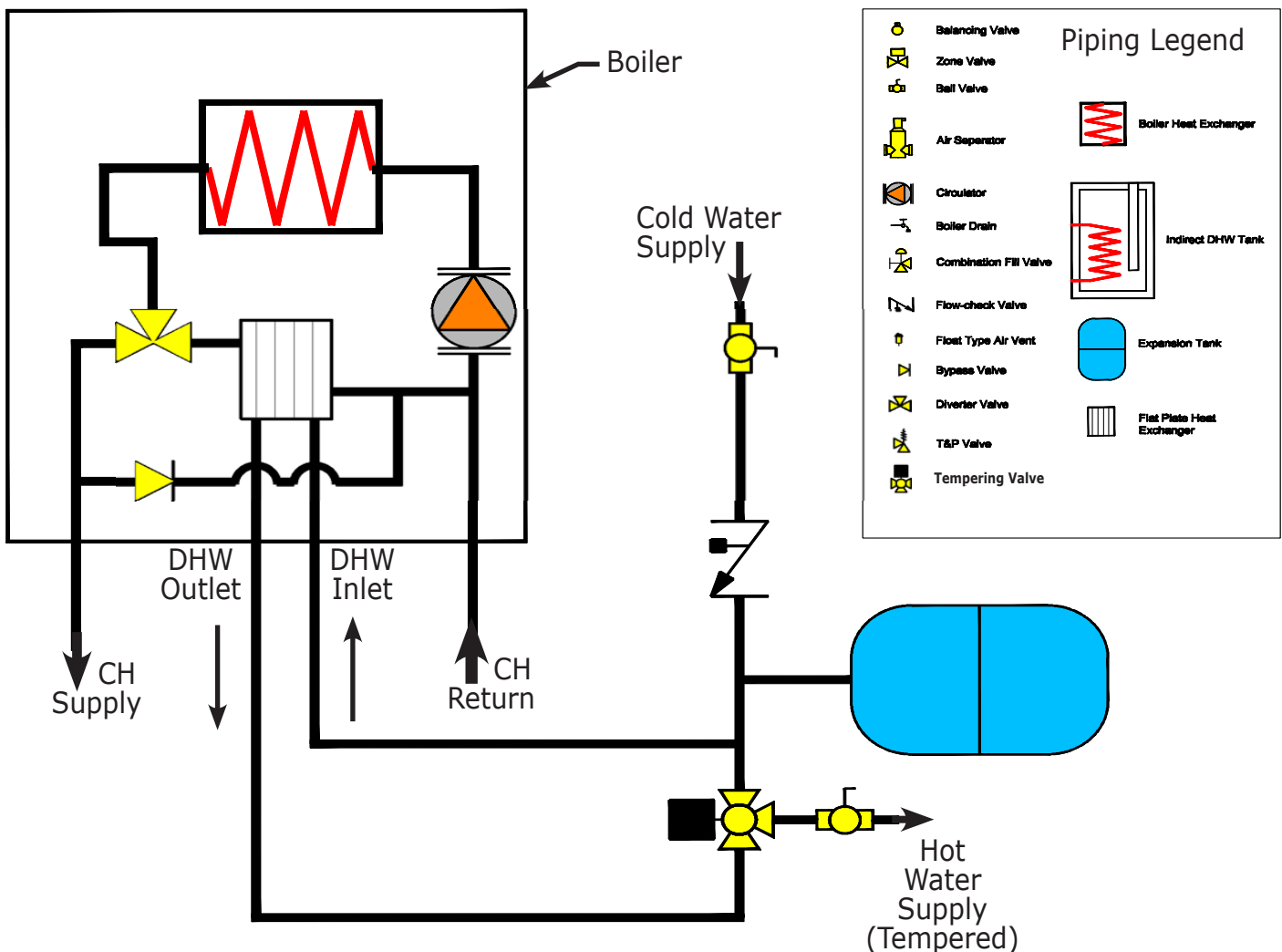
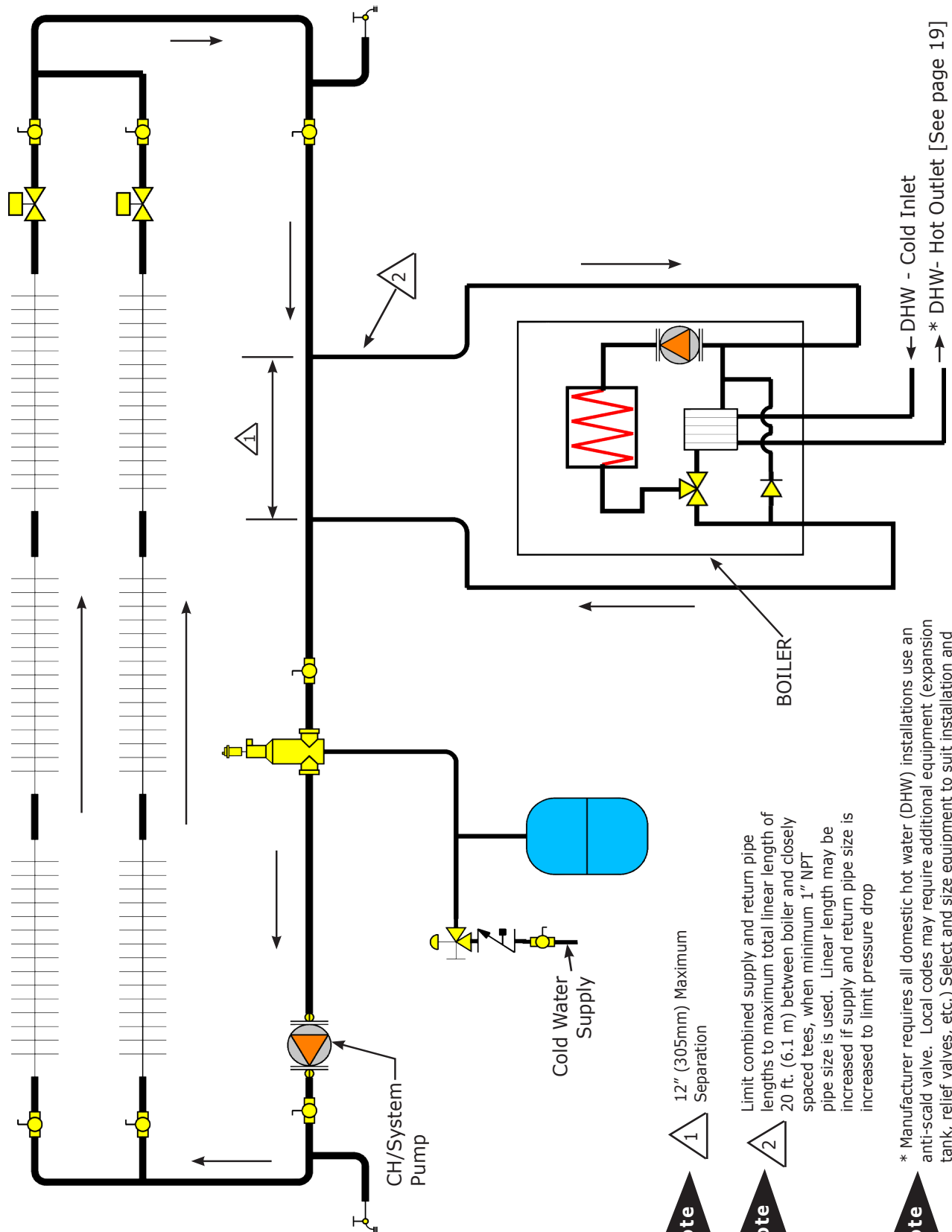

FIGURE 12 - CCB Single Boiler Primary/Secondary Series Loop Zoned System WITH ZONE VALVES



Note 1 12" (305mm) Maximum Separation

Note 2 Limit combined supply and return pipe lengths to maximum total linear length of 20 ft. (6.1 m) between boiler and closely spaced tees, when minimum 1" NPT pipe size is used. Linear length may be increased if supply and return pipe size is increased to limit pressure drop

Note * Manufacturer requires all domestic hot water (DHW) installations use an anti-scald valve. Local codes may require additional equipment (expansion tank, relief valves, etc.) Select and size equipment to suit installation and meet code requirements.

FIGURE 13 - CCB -Single Boiler Primary/Secondary Series Loop Zoned WITH ZONE PUMPS

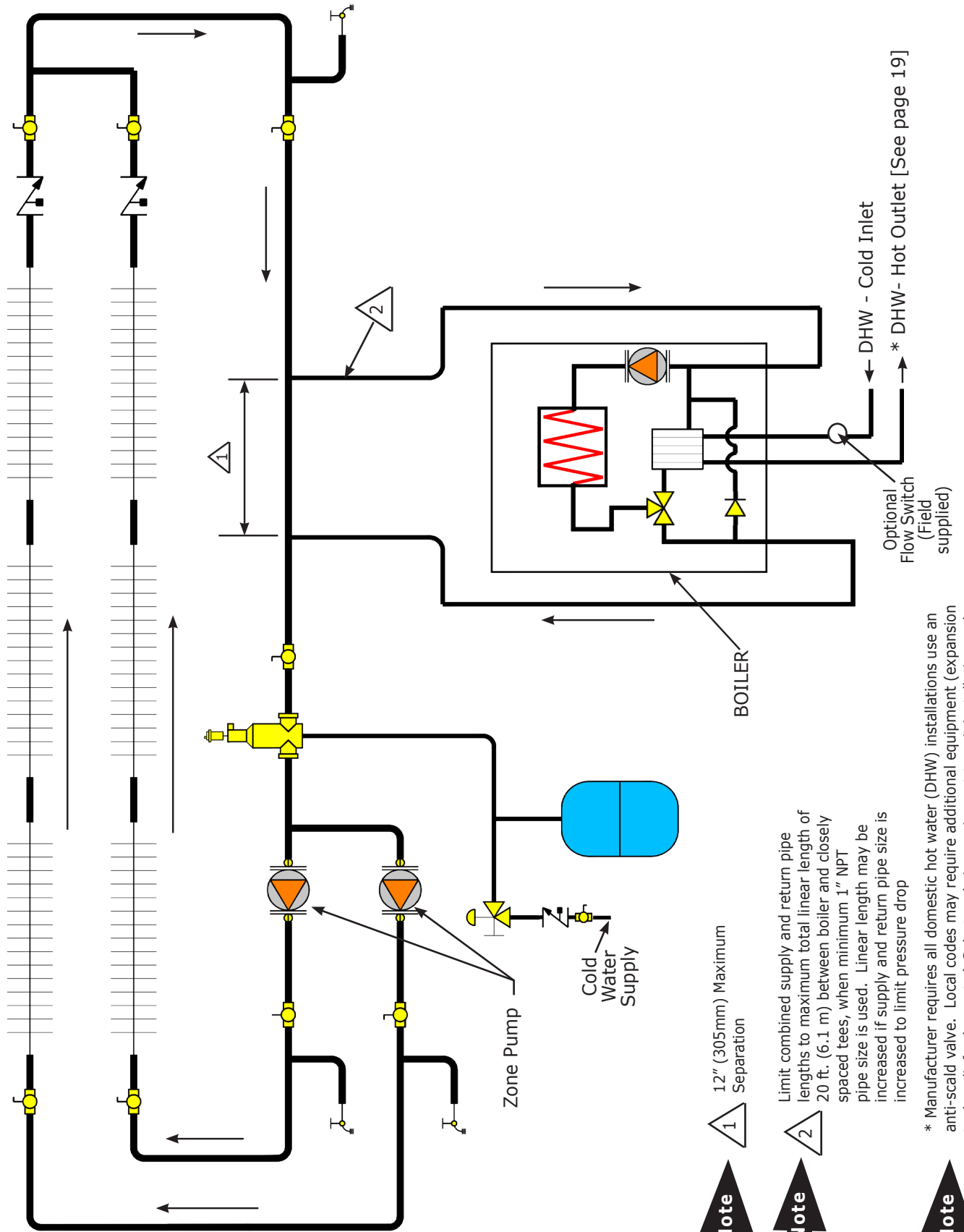

- Note** 1 12" (305mm) Maximum Separation
- Note** 2 Limit combined supply and return pipe lengths to maximum total linear length of 20 ft. (6.1 m) between boiler and closely spaced tees, when minimum 1" NPT pipe size is used. Linear length may be increased if supply and return pipe size is increased to limit pressure drop
- Note** * Manufacturer requires all domestic hot water (DHW) installations use an anti-scald valve. Local codes may require additional equipment (expansion tank, relief valves, etc.) Select and size equipment to suit installation and meet code requirements.

FIGURE 14 - CCB -Single Boiler Primary/Secondary Series Loop PUMPING

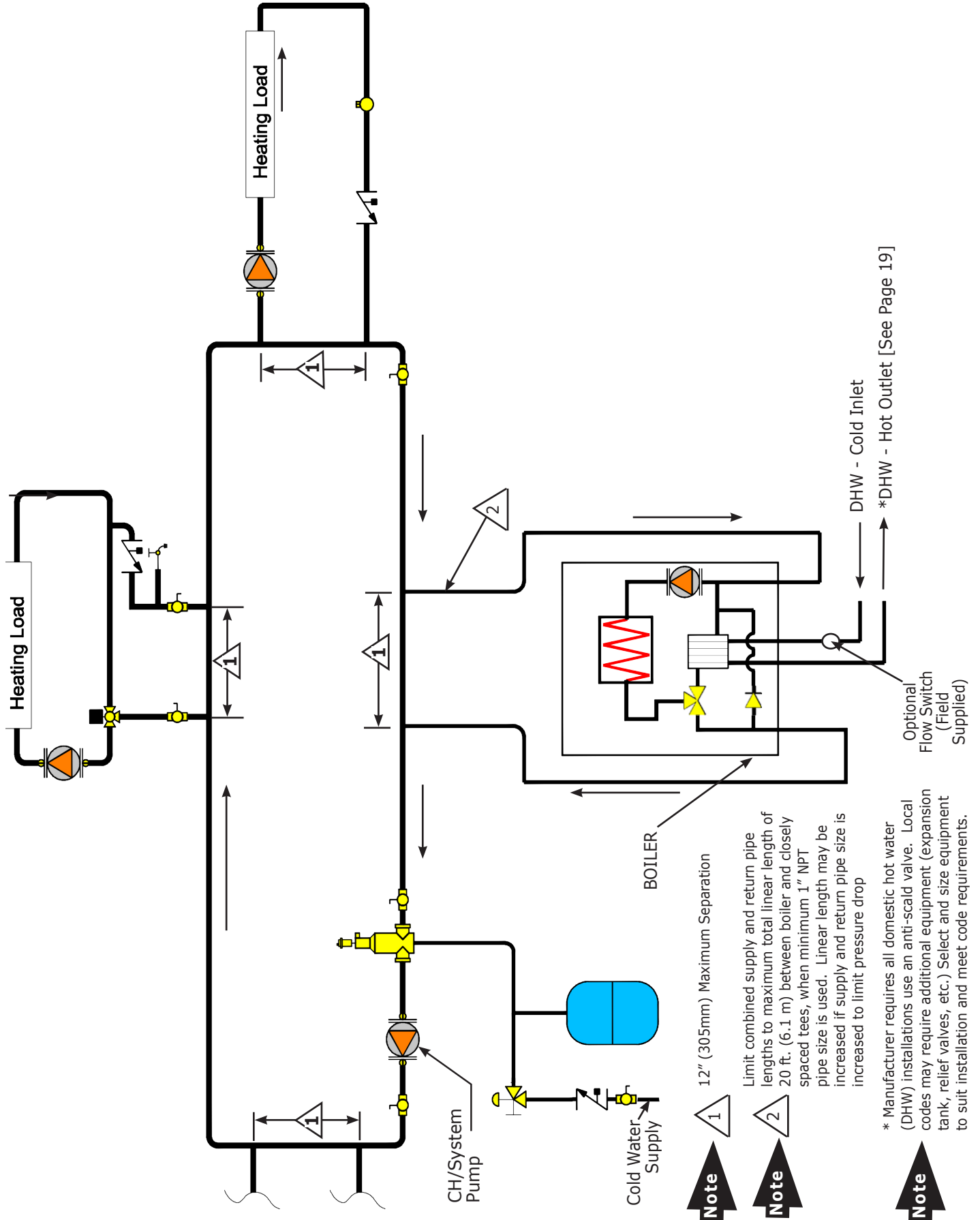

CCB BOILER - WIRING DIAGRAMS

1. CCB Boiler Wiring Diagrams

All field wiring shall conform to the authority having jurisdiction or, in the absence of such requirements to:

- USA:** National Electrical Code, ANSI/NFPA 70,
- Canada:** Canadian Electrical Code, Part I, CSA
C22.1: Safety Standard for Electrical Installations.

2. CCB/Single Zone

Single room thermostat (Key 72) will control the internal pump and boiler operation. Remove jumper when connecting the thermostat or zone equipment.

See Figure 15.

3. CCB When System Supply Pump is Needed:

- External system supply pump connection terminals (Key307) are being added to the rear of the control box and will be limited to an additional 1 AMP pump operation. Internal fusing will prevent higher pump operation. If a larger system pump is required use an isolation relay. See Wiring Figure 6.
- If the Controller **is not** equipped with these terminals, or a larger pump capacity is required. You will need to install an external pump/relay controller circuit. See Instructions And Wiring Diagram For Adding External Pump (615000137) provided with this manual.

NOTICE

Important:

- Before connecting to Key 72 Terminals remove jumper on terminal block.
- Before connecting Low Water Cutoff, remove jumper on terminal block. (Key 370)

Wiring Legend CHB/CCB

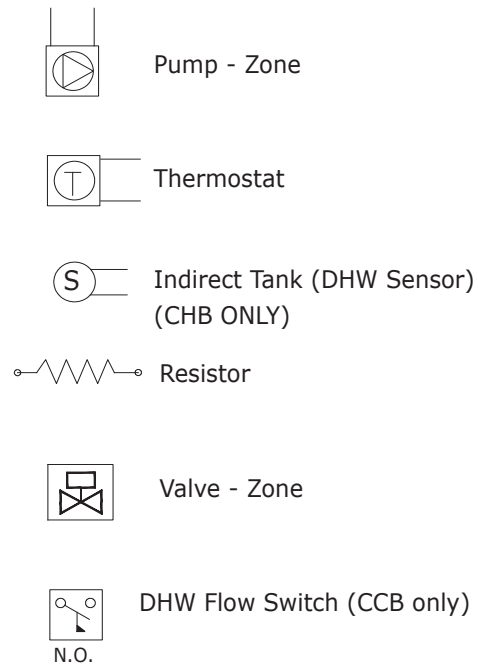
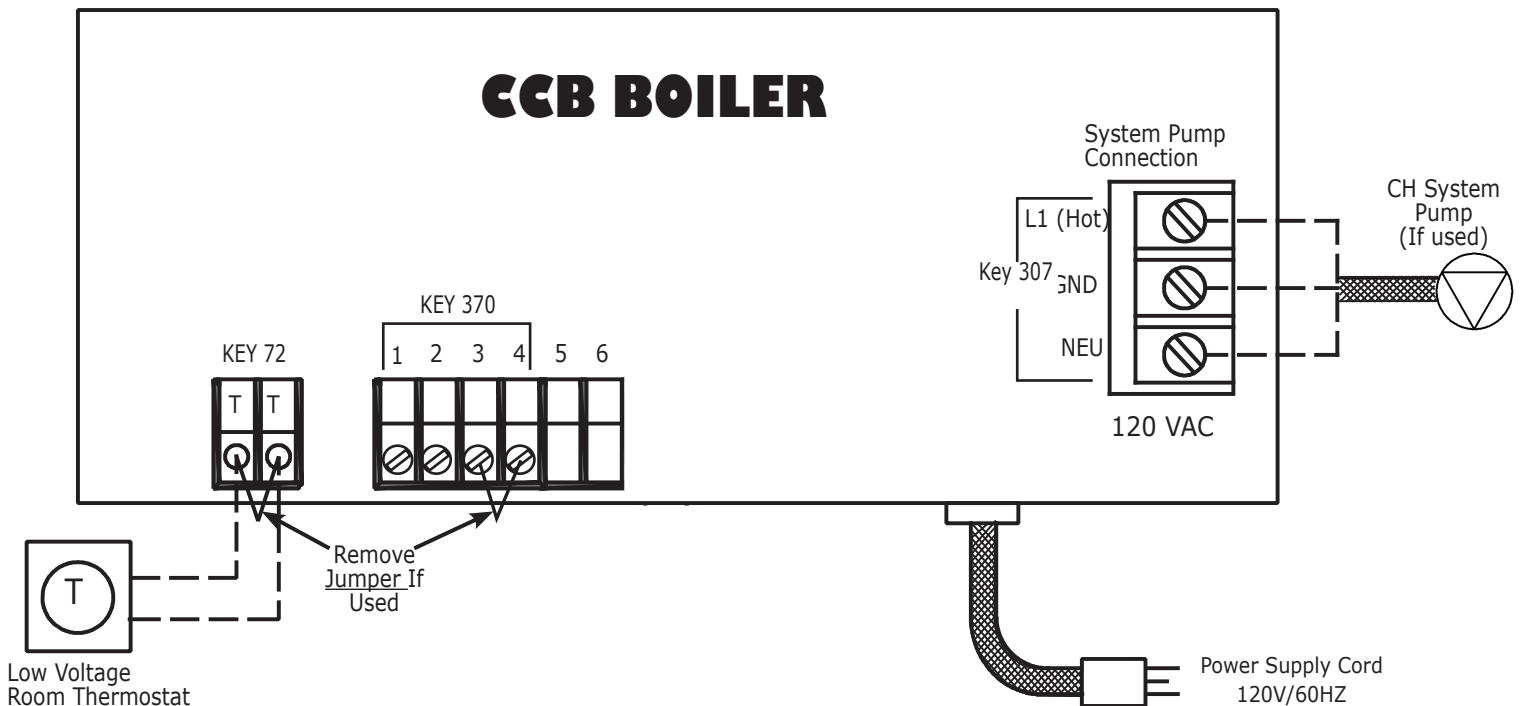

FIGURE 15 - CCB Boiler with Optional Supply System Pump



4. CCB - Using Multi-Zone Valve System

Boiler call for heat contacts (Key 72) are wired to Argo Zone Control (x-x) terminals. Zone thermostats and zone valves are to be wired to the Argo Zone Controller. See Figure 16.

Set Argo Priority Switch to OFF position. This disables priority operation and all zone valves will operate independently. Refer to Argo Controller instructions for switch setting and operation information.

NOTICE

Important:

- Before connecting to Key 72 Terminals, remove jumper on terminal block. (Key 72)
- Before connecting Low Water Cutoff, remove jumper on terminal block. (Key 370)

FIGURE 16 - CCB Boiler with Multiple Zone Valves

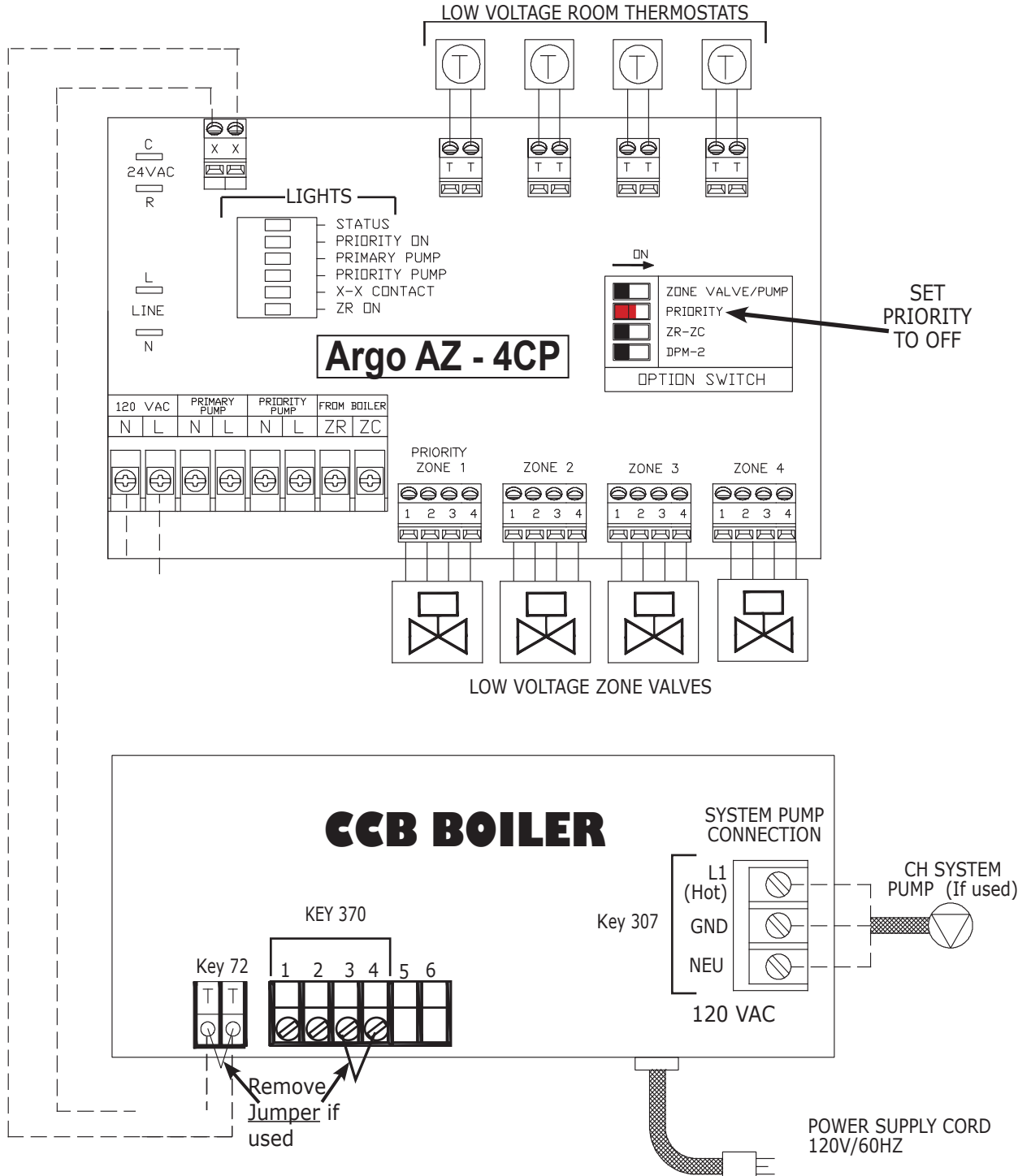

5. CCB Using Multi-Zone Pump System

Wiring of Argo Control may include Priority Zone Control.

Boiler thermostat contacts (Key 72) are wired to Argo ARM Zone Pump Control terminals (x-x). Use Argo ARM Zone Pump Controller and wire as shown in Figure 17 or 18.

1. When priority zone control is **not** desired. Wire zone pumps and thermostats as shown in Figure 17. Set Priority to OFF. Secondary zone pumps **Will Not** shutoff during DHW call for heat.
2. When priority zone control **is** desired, wire zone pumps and thermostats as shown in Figure 18. Wire priority flow controller (not supplied) across Zone 1 (Priority) thermostat connections. Zone 1 pump terminals are not used, unless a Priority Pump is being applied. Set the Argo Priority switch to ON, secondary pumps **Will** shutoff during DHW call for heat.

NOTICE

Important:

- Before connecting to room Key 72 Terminals, remove jumper on terminal block.
- Before connecting Low Water Cutoff, remove jumper on terminal block. (Key 370)

CCB BOILER - WIRING DIAGRAMS

FIGURE 17 - CCB Boiler with Multiple Zone Pumps WITHOUT DHW Interface

NOTICE

Important:

- Before connecting to Argo Control remove jumper on terminal block. (Key 72)
- Before connecting Low Water Cutoff remove jumper on terminal block. (Key 370)

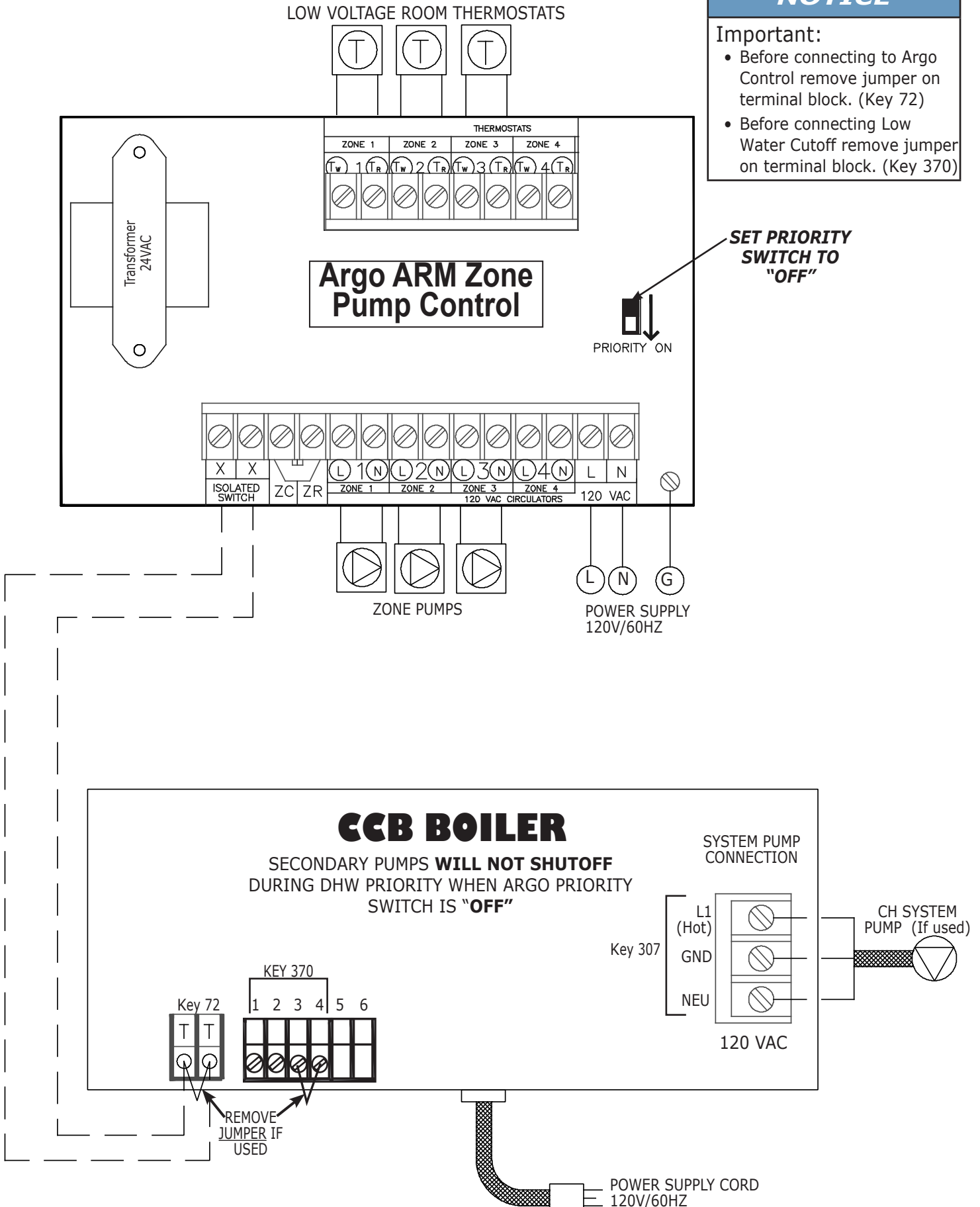

SET PRIORITY SWITCH TO "OFF"

CCB BOILER - WIRING DIAGRAMS

FIGURE 18 - CCB Boiler with Multiple Zone Pumps WITH DHW Interface

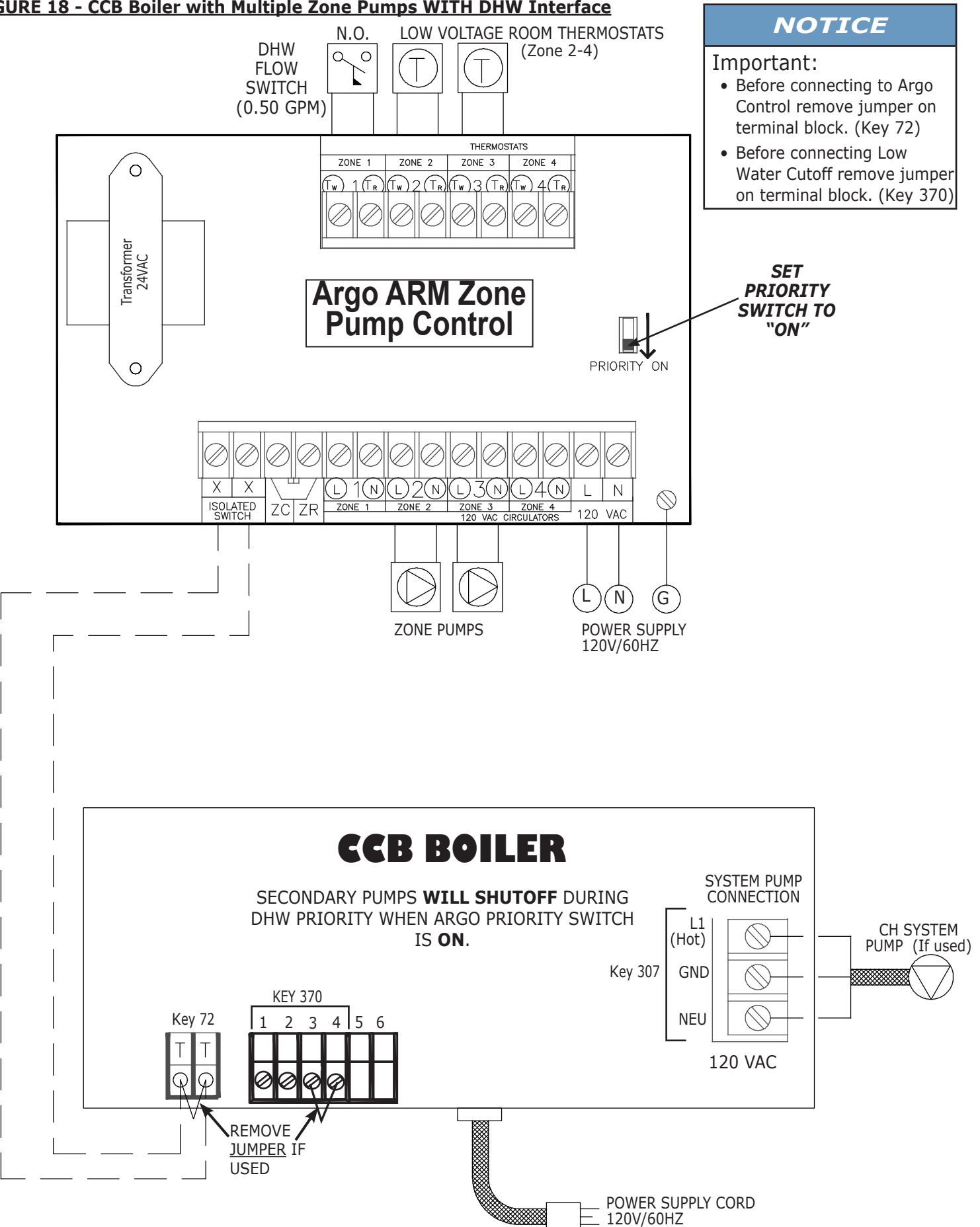

APPLICATION TABLES FOR : CHB - INDIRECT HOT WATER TANK

3/4" PIPE		
EQUIV. PIPE LENGTH (FEET)	INTERNAL PUMP (GPM)	PRESS. HEAD FROM BOILER (FT - H ₂ O)
10 FT.	7.4	3.0
30 FT.	6.9	5.2
50 FT.	6.5	6.8

1" PIPE		
EQUIV. PIPE LENGTH (FEET)	INTERNAL PUMP (GPM)	PRESS. HEAD FROM BOILER (FT - H ₂ O)
20 FT.	7.5	2.5
50 FT.	7.3	3.6
100 FT.	6.9	5.2

1- 1/4" PIPE		
EQUIV. PIPE LENGTH (FEET)	INTERNAL PUMP (GPM)	PRESS. HEAD FROM BOILER (FT - H ₂ O)
50 FT.	7.5	2.6
100 FT.	7.4	3.0
200 FT.	7.3	3.5

AVAILABLE PUMP HEAD vs FLOW for DHW INDIRECT TANK

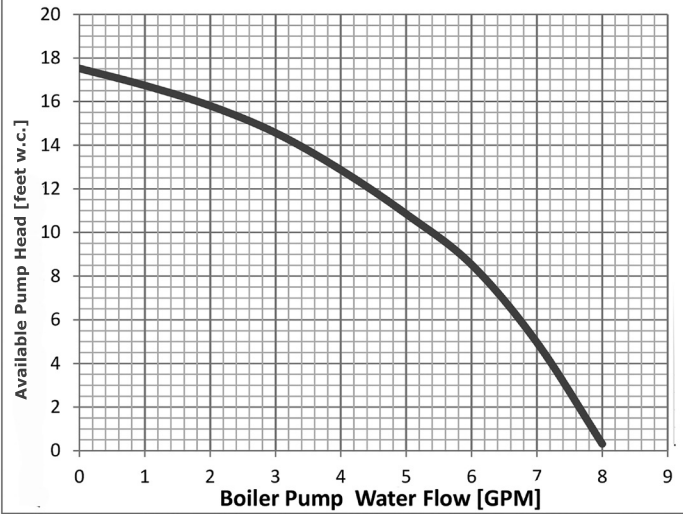

Available pump head Feet water column	Flow US GPM
17.52	0
16.74	1
15.81	2
14.57	3
12.87	4
10.85	5
8.53	6
4.96	7
0.31	8

— CHB 100, CHB130, CHB150

CONTINUOUS RATING @ MAXIMUM INPUT (GAL/HR.)

INDIRECT TANK - H2O30 / H2O40 / H2O40 L / H2O50
H2O60 / H2O60 L / H2O80 / H2O115

GPM	CHB-100		CHB-130		CHB-150	
	140 °F	115 °F	140 °F	115 °F	140 °F	115 °F
7.5	113	156	146	202	151 / 169	209 / 234
7.3	110	152	142	197	147 / 164	203 / 228
7.0	106	146	136	189	141 / 158	195 / 218
6.5	98	135	127	175	131 / 146	181 / 203

APPLICATION TABLES FOR : CHB - INDIRECT HOT WATER TANK

Table Based on Boiler Flow Rate = 7.5 GPM		CHB-100 BOILER (100,000 BTUH MAXIMUM INPUT RATE)				CHB-130 BOILER (130,000 BTUH MAXIMUM INPUT RATE)				CHB-150 BOILER (150,000 BTUH MAXIMUM INPUT RATE)								
		BOILER OUTPUT (BTUH/HR)		MAX. 85,000		BOILER OUTPUT (BTUH/HR)		MAX. 110,000		BOILER OUTPUT (BTUH/HR)		MAX. 128,000						
		50,000	60,000	80,000		50,000	60,000	80,000	100,000	50,000	60,000	80,000	100,000	120,000	MAX.			
H2O30		140 F (GAL/HR)	94	107	134	140		94	107	134	160	173		94	107	134	160	170
		115 F CONTINUOUS	119	138	174	183		119	138	174	211	229		119	138	174	211	225
		140 F RATING (GAL/HR)	67	80	107	113		67	80	107	133	146		67	80	107	133	143
		115 F	92	111	147	156		92	111	147	184	202		92	111	147	184	198
H2O40 / H2O40L																		
		140 F (GAL/HR)	103	116	143	149		103	116	143	169	182		103	116	143	169	187 / 180
		115 F CONTINUOUS	128	147	183	192		128	147	183	220	238		128	147	183	220	245 / 235
		140 F RATING (GAL/HR)	67	80	107	113		67	80	107	133	146		67	80	107	133	151 / 144
		115 F	92	111	147	156		92	111	147	184	202		92	111	147	184	209 / 199
H2O50																		
		140 F (GAL/HR)	112	125	152	158		112	125	152	178	191		112	125	152	178	190
		115 F CONTINUOUS	137	156	192	201		137	156	192	229	247		137	156	192	229	248
		140 F RATING (GAL/HR)	67	80	107	113		67	80	107	133	146		67	80	107	133	160
		115 F	92	111	147	156		92	111	147	184	202		92	111	147	184	221
H2O60 / H2O60L																		
		140 F (GAL/HR)	121	134	161	167		121	134	161	187	200		121	134	161	187	196 / 187
		115 F CONTINUOUS	146	165	201	210		146	165	201	238	256		146	165	201	238	257 / 245
		140 F RATING (GAL/HR)	67	80	107	113		67	80	107	133	146		67	80	107	133	160 / 151
		115 F	92	111	147	156		92	111	147	184	202		92	111	147	184	221 / 209
H2O80																		
		140 F (GAL/HR)	139	152	179	185		139	152	179	205	218		139	152	179	205	190
		115 F CONTINUOUS	164	183	219	228		164	183	219	256	274		164	183	219	256	252
		140 F RATING (GAL/HR)	67	80	107	113		67	80	107	133	146		67	80	107	133	160
		115 F	92	111	147	156		92	111	147	184	202		92	111	147	184	221
H2O115																		
		140 F (GAL/HR)	170	183	210	216		170	183	210	236	249		170	183	210	236	196
		115 F CONTINUOUS	195	214	250	259		195	214	250	287	305		195	214	250	287	270
		140 F RATING (GAL/HR)	67	80	107	113		67	80	107	133	146		67	80	107	133	160
		115 F	92	111	147	156		92	111	147	184	202		92	111	147	184	221

NOTES:
180 °F Boiler Supply Water Temperature
AHRI Rating Conditions - 50 °F Inlet Water

VENTING OPTIONS

TYPE I - VENTING (ACCEPTABLE)

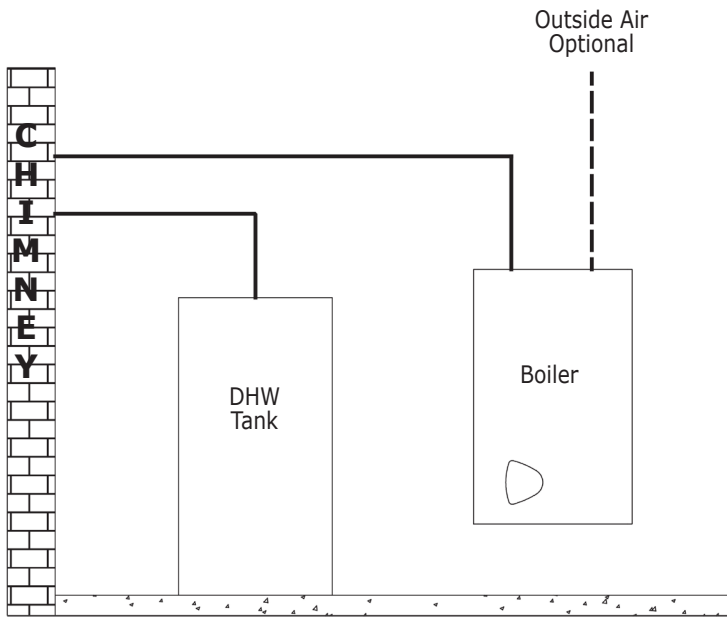

TYPE I - VENTING (ACCEPTABLE)

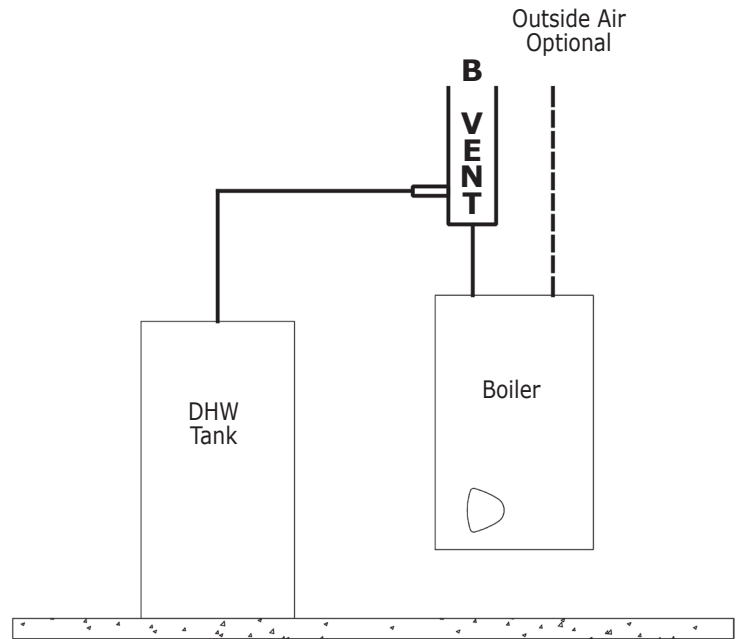

TYPE I - VENTING (NON-ACCEPTABLE)

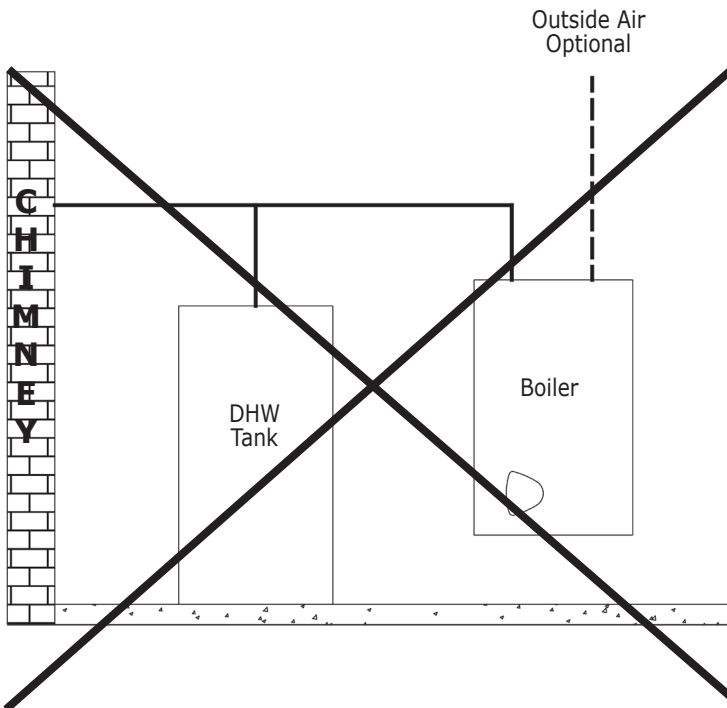

TYPE I - VENTING (NON-ACCEPTABLE)

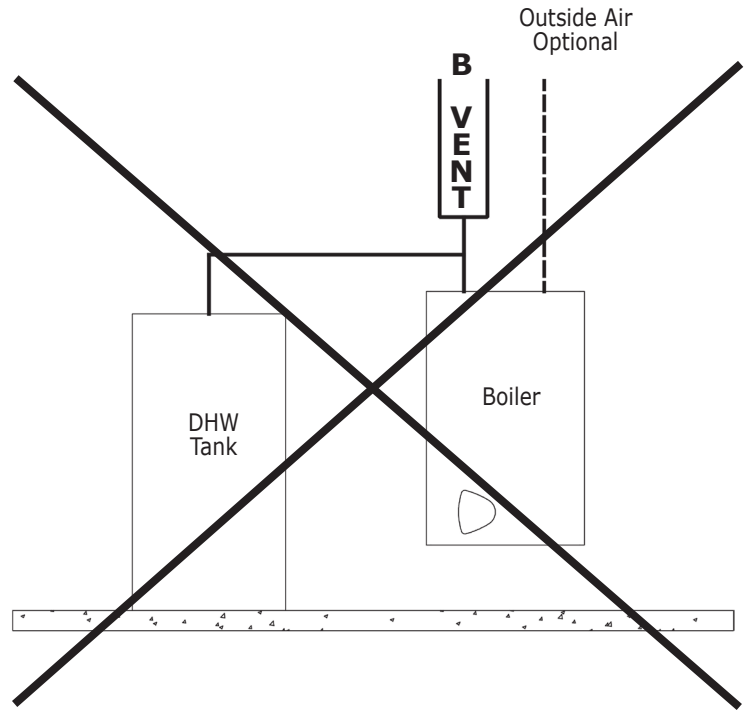

OPTIONAL EQUIPMENT - SENSORS

Optional Equipment

1. Outdoor Air Sensor, if used.
 - A. See Chart 1 for sensor data. Sensor part number FE013018X0.
 - B. Locate outdoor sensor to protect against wind and direct sunlight. Mounting instructions provided with sensor.
 - C. Maximum wire length is 100 ft (30m) for 22 ga. wire, or 150 ft (45m) for 18 ga. wire.
 - D. Connect wires to OUTDOOR SENSOR terminals. Wires are interchangeable.

2. NTC Sensor for DHW tank, if used.
 - A. Recommend part number - FE043005X0
See Chart 1 for sensor data.
See Installation, Operation and Maintenance Manual for wiring diagram for connections.

CHART 1 - OUTDOOR AIR SENSOR & NTC SENSOR DATA

°F	R Ω	°F	R Ω	°F	R Ω	°F	R Ω
-4	96125	32	32505	68	12483	104	5332
-2.2	90743	33.8	30898	69.8	11935	105.8	5123
-0.4	85694	35.6	29381	71.6	11414	107.6	4923
1.4	80959	37.4	27946	73.4	10919	109.4	4732
3.2	76510	39.2	26590	75.2	10447	111.2	4549
5	72335	41	25308	77	9999	113	4374
6.8	68412	42.8	24094	78.8	9572	114.8	4207
8.6	64725	44.6	22946	80.6	9166	116.6	4047
10.4	61259	46.4	21859	82.4	8779	118.4	3894
12.2	57999	48.2	20829	84.2	8411	120.2	3748
14	54932	50	19854	86	8060	122	3608
15.8	52045	51.8	18930	87.8	7726	123.8	3473
17.6	49327	53.6	18054	89.6	7407	125.6	3345
19.4	46767	55.4	17223	91.4	7103	127.4	3222
21.2	44354	57.2	16436	93.2	6813	129.2	3104
23	42080	59	15689	95	6537	131	2991
24.8	39936	60.8	14980	96.8	6273	132.8	2882
26.6	37914	62.6	14306	98.6	6021	134.6	2778
28.4	36006	64.4	13667	100.4	5781	136.4	2679
30.2	34205	66.2	13060	102.2	5551	138.2	2583

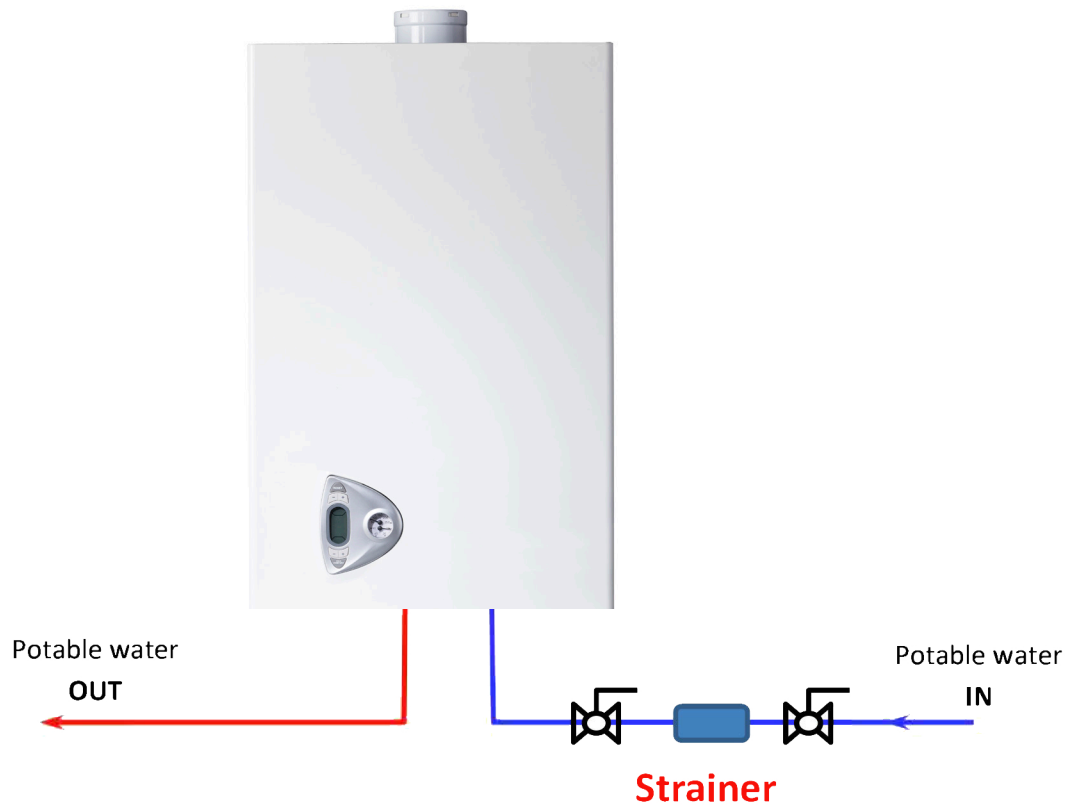

Manufacturer Recommendation

A strainer filtering potable water before entering the boiler is highly recommended to prevent errors and lockouts. The strainer prevents any sedimentation and debris from your water supply piping from entering the boiler. Debris carried from the water supply will clog DHW water flow sensor resulting in error codes and causing boiler to lockout.

Locate the strainer as close to the boiler as possible and place on DHW (domestic hot water) inlet connection located at bottom of the boiler.

Low Water Cut Off - Heating Only and Combi Boilers

These guidelines are supplied when necessary to install an additional Low Water Cut Off (LWCO), for sensing a low water level condition in a boiler, as required by the Authority Having Jurisdiction.

Follow LWCO manufacturer installation instructions for type of LWCO selected in addition to these instructions.

LWCO shall be 120V/60HZ and dry contacts sized for load being connected. Wire LWCO to boiler. See Page 35, LWCO Wiring Diagram, Key 370.

Connect LWCO device to the system ground. Ground in accordance with the requirements of the authority having jurisdiction or, in the absence of such requirements, with the National Electrical Code (NEC) or Canadian Electrical Code CEC.

- Locate LWCO sensing device in the supply piping, above the minimum height of boiler. See page 36, LWCO Piping Diagram.
- Position control in HORIZONTAL piping to assure proper boiler protection (upright or 90° rotation).
- For proper operation, sensing element of the LWCO control shall be positioned in the tee to sense the main water stream. Maintain minimum 1/4" spacing from pipe walls. Element shall NOT contact the rear, or side walls of the tee. See Page 37, LWCO Detail.
- Install an air vent using a tee to avoid nuisance shutdowns.
- Apply small amount of pipe sealant to threaded connections.
- Arrange piping to prevent water dripping onto boiler.
- DO NOT install water shutoff valve between boiler and LWCO sensing device.

OPTIONAL EQUIPMENT - LOW WATER CUTOFF

LWCO Wiring Diagram

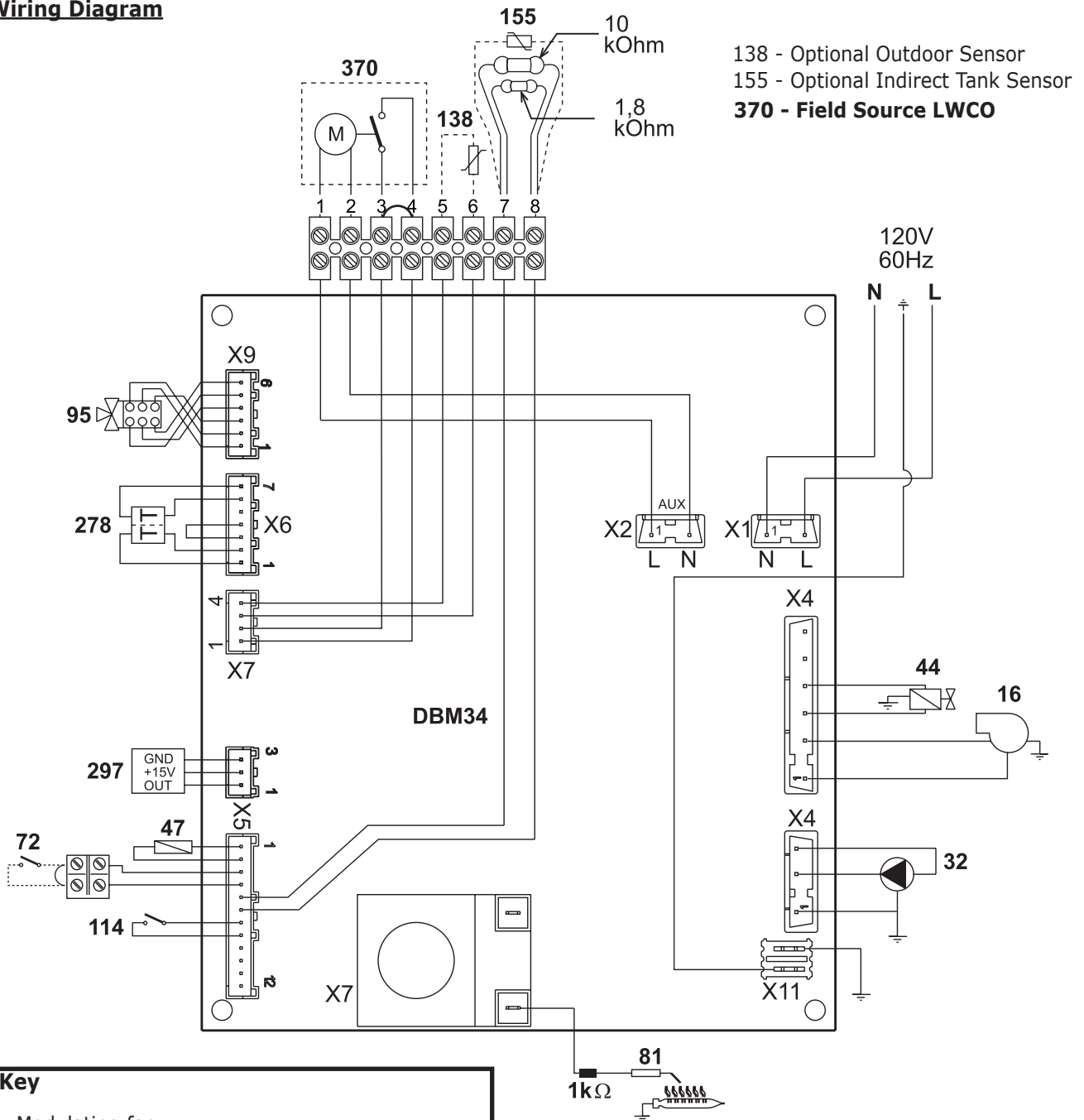

Key

- | | |
|------------|--|
| 16 | Modulating fan |
| 32 | Heating circulating pump |
| 42 | DHW temperature sensor (see kit) |
| 44 | Gas valve |
| 47 | Modulation Regulator (24V) |
| 72 | Room thermostat (field sourced) |
| 81 | Ignition/detection electrode |
| 114 | Water pressure switch |
| 138 | External probe (not fitted) |
| 155 | Hot water tank temperature probe (field sourced) |
| 278 | Double sensor (Safety + Heating) |
| 297 | Air pressure transducer |
| 370 | Low Water Cutoff (LWCO) (field sourced) |

NOTICE

*IMPORTANT:

- Before connecting the room thermostat, remove jumper on terminal block. (Key 72)
- Before connecting optional Indirect Tank Sensor, remove two resistors, (Key 155)
- Before connecting the Low Water Cutoff, remove the jumper on terminal block. (Key 370)

OPTIONAL EQUIPMENT - LOW WATER CUTOFF

Piping Diagram - LWCO Location

Low Water Cutoff (LWCO)

Note

Arrange piping to prevent water dripping onto boiler.

Note

Illustrations are meant to show system piping concept only. Installer is responsible for all equipment and detailing required by authority having jurisdiction.

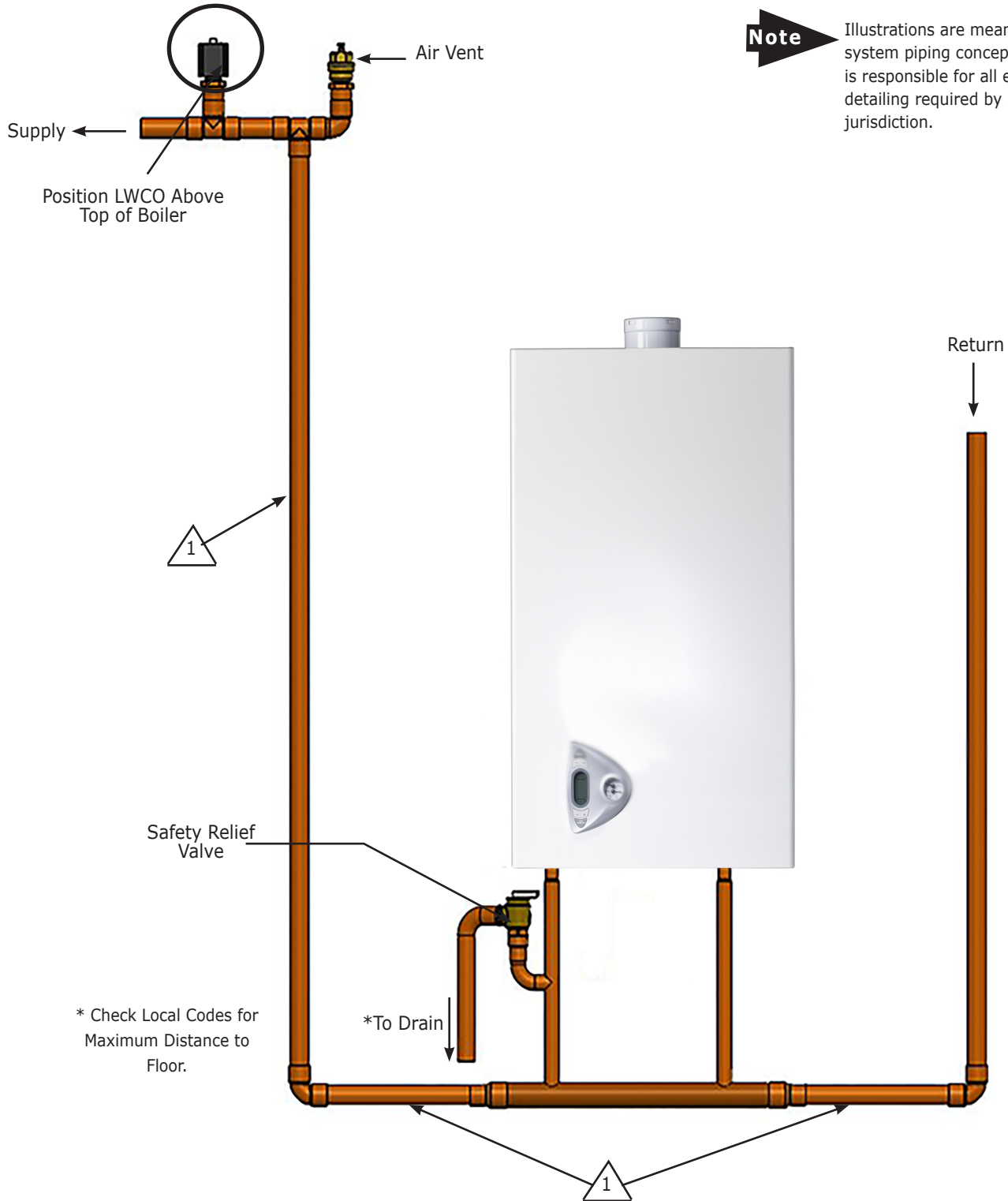

Note



DO NOT PLACE ISOLATION VALVE BEFORE TEE OR LWCO.

OPTIONAL EQUIPMENT - LOW WATER CUTOFF

Low Water Cutoff - Detail

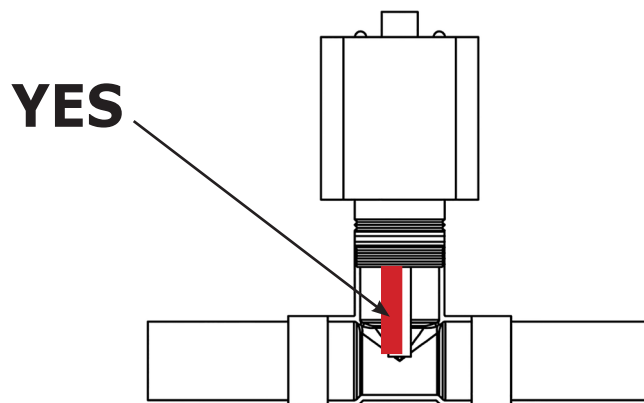
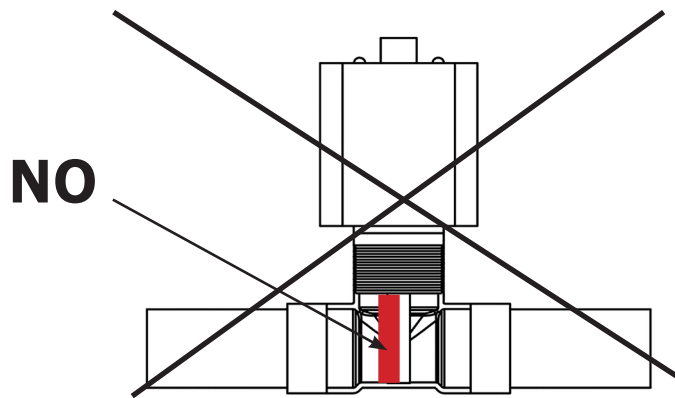
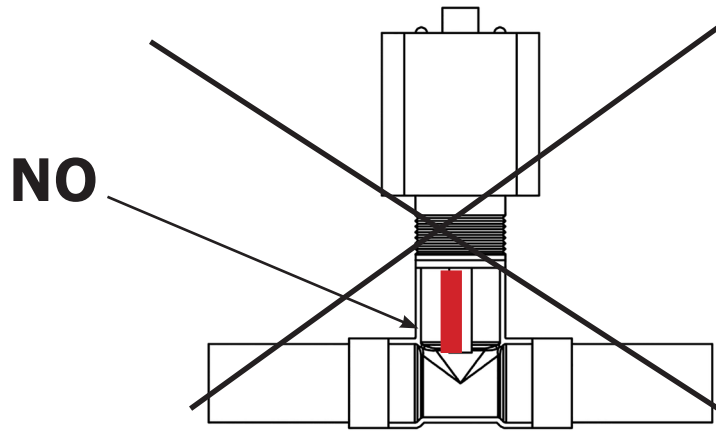

Addendum - Instructions

Following Section Includes:	Page #(s)
Domestic Hot Water Sensor Kit Instruction (240010745).....	39-42
Instructions And Wiring Diagram For Adding External Pump (615000137).....	43-44
Sealed Combustion Kit Instructions (37711601) - For Kit #5612601.....	45
Control Board Replacement Kit Instructions (615000134).....	46-47
Retaining Clip Removal Caution (615000136).....	48-49
Altitude Affects on CHB-100, CHB-130, CHB-150 and CCB-150.....	50
LP Conversion Kit Instructions.....	51-53
DHW Resistor Harness and Relay Kit (550003082).....	54-57
Combustion Cover Replacement Kit Instructions (55000xxxx).....	58

DOMESTIC HOT WATER SENSOR KIT

INSTRUCTIONS FOR CHB-100, CHB-130, CHB-150

Kit #550002958

Kit installation shall be completed by qualified agency.

⚠ WARNING

Fire, explosion, asphyxiation and electrical shock hazard. Improper installation could result in death or serious injury. Read this instruction and understand all requirements, including requirements of authority having jurisdiction, before beginning installation. Installation not complete until appliance operation verified per Installation, Operation & Maintenance Manual provided with boiler.

Sensor can be used on a standard Indirect Hot Water tank. When it is connected to the boiler, sensor will control Indirect Tank temperature.

1. Follow instructions To TURN OFF GAS TO APPLIANCE found on Operating Instructions label on boiler or in Installation, Operation & Maintenance Manual. Verify all electrical power to boiler is turned off.

⚠ WARNING

Electrical shock hazard. Turn OFF electrical power supply at service panel.

2. Remove front jacket.

⚠ WARNING

Burn hazard. Verify heat exchanger has cooled or use appropriate personal protection equipment.

3. Before inserting sensor into Indirect tank well, thoroughly coat sensor with Thermopaste supplied with sensor kit.
4. Slide sensor into well until it bottoms out. See Figure 1.
5. Secure sensor wire to well with included clip. See Figures 1, 2 and 3.
6. Route sensor wire to boiler low voltage terminal block. Remove the two resistors on terminals 7 & 8 of 8-pin terminal strip, key #155. See Figure 4 - wiring diagram.
7. Install sensor wires onto terminals 7 & 8. See Figures 5 and 6.
8. Secure sensor wire, provide adequate strain relief and anti-shorting protection.

Figure 1 - Slide Sensor Into well of Indirect Tank



Figure 2 - Secure Sensor Wire to Well With Clip



Figure 3 - Sensor Wire Secured to Well With Clip



DOMESTIC HOT WATER SENSOR KIT

9. Restore power to boiler. Boiler will automatically recognize the sensor.
10. See Installation, Operation & Maintenance Manual for adjusting DHW tank temperature and operation.
11. Resume operation using Installation, Operation & Maintenance Manual.
12. Verify proper operation by following START UP PROCEDURE in Installation, Operation & Maintenance Manual.
13. Install front cover.

DOMESTIC HOT WATER SENSOR KIT FOR CHB-100/ CHB-130/ CHB150 #550002958		
DESCRIPTION	PART #	QTY
DHW Tank Sensor	-	1
Clip	-	1
Thermopaste	-	1
Instructions	240010745	1

DOMESTIC HOT WATER SENSOR KIT

Figure 4 - Wiring Diagram

If Key 155 is used remove both resistors and wire Indirect Tank Sensor to terminals 7 and 8.

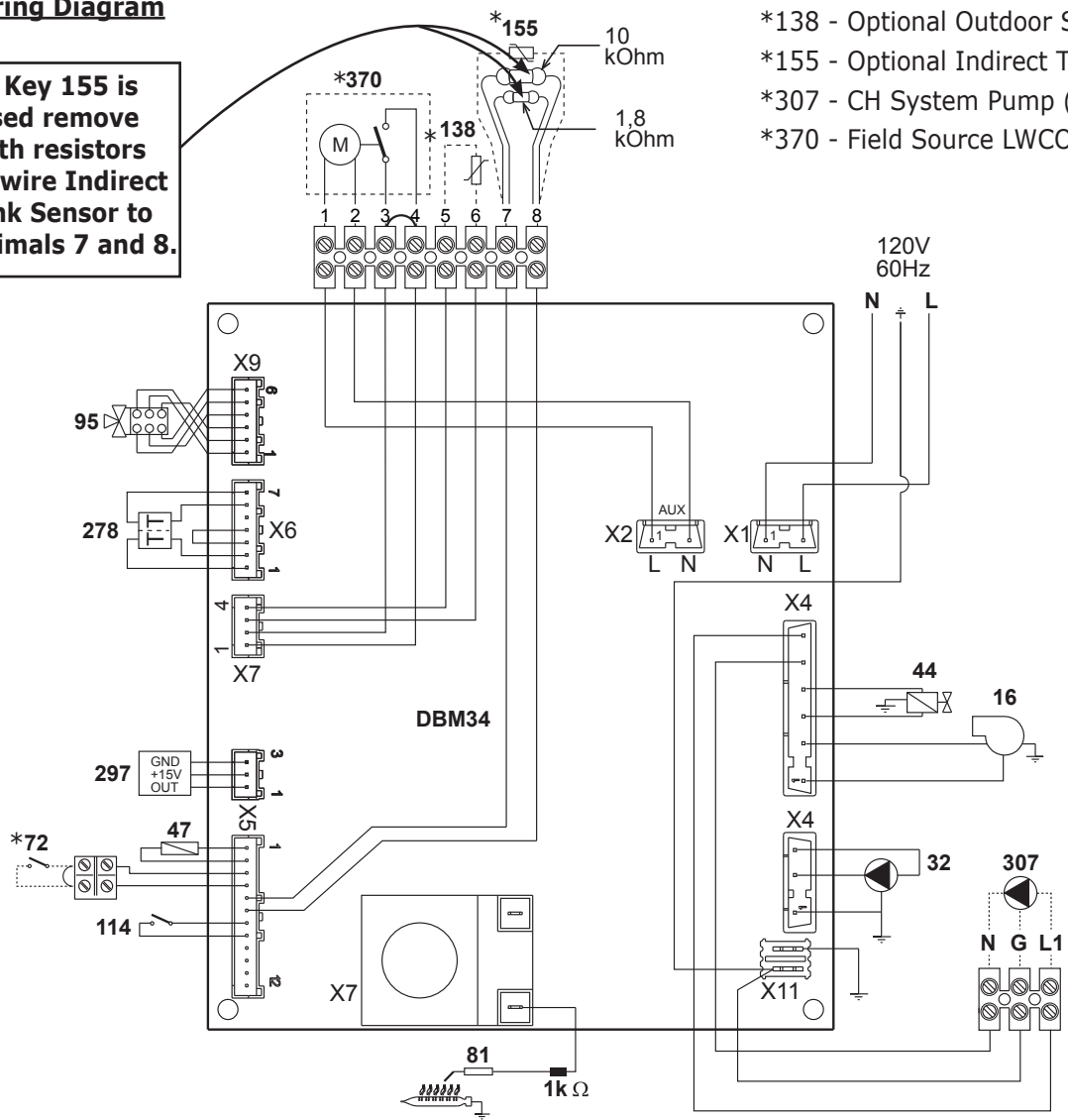

- *138 - Optional Outdoor Sensor
- *155 - Optional Indirect Tank Sensor
- *307 - CH System Pump (if used)
- *370 - Field Source LWCO

Key

- 16** Modulating fan
- 32** Heating circulating pump
- 42** DHW temperature sensor (see kit)
- 44** Gas valve
- 47** Modulation Regulator (24V)
- *72** Room thermostat (field sourced)
- 81** Ignition/detection electrode
- 114** Water pressure switch
- *138** Optional Outdoor Sensor (field sourced)
- *155** Optional Indirect Tank Sensor (See parts list)
- 278** Double sensor (Safety + Heating)
- 297** Air pressure transducer
- *307** CH Sysetm Pump - (if applicable)
- *370** Low Water Cutoff (LWCO) - (field sourced)

NOTICE

*Important:

- Before connecting the room thermostat, remove jumper on terminal block. (Key 72)
- Before connecting optional Indirect Tank Sensor, remove two resistors. (Key 155)
- Before connecting the Low Water Cutoff, remove the jumper on terminal block. (Key 370)

DOMESTIC HOT WATER SENSOR KIT

Figure 5 - Low Voltage Terminal Strip, CHB-130 Shown

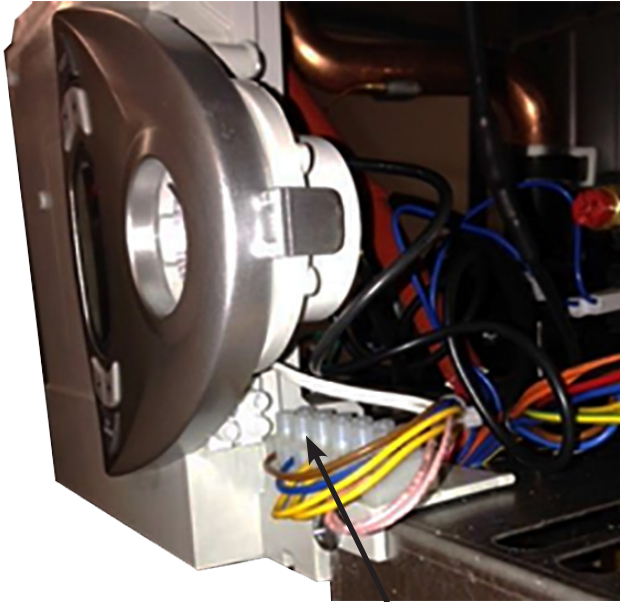

Low Voltage Terminal Strip

Figure 6 - Low Voltage Terminal Strip Removed from Boiler, CHB -130 Shown



Low Voltage Terminal Strip Removed

Temperature Deg F	Resistance in Ohms
32	32505
60	15689
70	11935
77	10000
100	8060
110	4732
120	3748
130	3104

Check our website frequently for updates: www.ecrinternational.com

INSTRUCTIONS AND WIRING DIAGRAM FOR ADDING EXTERNAL PUMP TO CHB/CCB BOILERS (Without Factory Pump Terminals)

Installation shall be completed by qualified agency.

WARNING

Fire, explosion, asphyxiation and electrical shock hazard. Improper installation could result in death or serious injury. Read this instruction and understand all requirements, including requirements of authority having jurisdiction, before beginning installation. Installation not complete until appliance operation verified per Installation, Operation & Maintenance Manual provided with boiler.

An external pump is necessary for the following conditions:

- The central heating circuit exceeds 8 ft of total head loss.
- When using an indirect tank with a high head loss.

1. Follow instructions to TURN OFF GAS TO APPLIANCE found on Operation Instructions label on boiler or in Installation, Operation & Maintenance Manual. Verify all electrical power to boiler is turned off.

WARNING

Electric shock hazard. Turn OFF electrical power supply at service panel.

2. Verify all power to boiler is turned OFF at service panel.
3. Follow Installation, Operation & Maintenance manual to remove front jacket panel(s).

WARNING

Burn hazard. Verify heat exchanger has cooled or use appropriate personal protection equipment.

4. Inspect combustion chamber through sight glass. Verify flame is not present.
5. See wiring as shown in Figure 1.
6. Resume operation using OPERATING INSTRUCTIONS found on Operating Instructions label on boiler or in Installation, Operation & Maintenance Manual.
7. Verify proper operation by following START UP PROCEDURE in Installation, Operation & Maintenance Manual.
8. Follow Installation, Operation & Maintenance manual to install front jacket panel(s).

Sealed Combustion Termination

Kit # 5612601

Installation Instructions

Kit installation shall be completed by qualified agency.

⚠ WARNING

Fire, explosion, asphyxiation and electrical shock hazard. Improper installation could result in death or serious injury. Read this instruction and understand all requirements, including requirements of authority having jurisdiction, before beginning installation. Installation not complete until appliance operation is verified per Installation, Operation & Maintenance Manual provided with boiler.

Horizontal (Category III) venting systems installation shall conform to the requirements of the authority having jurisdiction or, in the absence of such requirements:

- National Fuel Gas Code, ANSI Z223.1/NFPA 54, and/or
- Natural Gas and Propane Installation Code, CAN/CSA B149.1

Installation Instructions:

1. Use supplied template to cut a hole through the wall. Secure template to inside wall.

NOTICE

If installing through non-combustible wall, remove termination thimble. Make two (2) 3½" ±1" holes on center through the wall.

2. Install vent termination assembly to outside wall.
3. Install PVC pipe from vent termination assembly to boiler's air inlet.
4. Assemble vent pipe following vent pipe manufacturer's instructions.
5. Install vent pipe through termination assembly and extend 3" beyond the assembly.
6. Install termination deflector using four (4) provided screws.
7. Install draw collar around vent pipe. Tighten nut and screw until secured tightly.
8. Secure termination tee according to vent pipe manufacturer's instructions.

Figure 1 - Sealed Combustion Termination

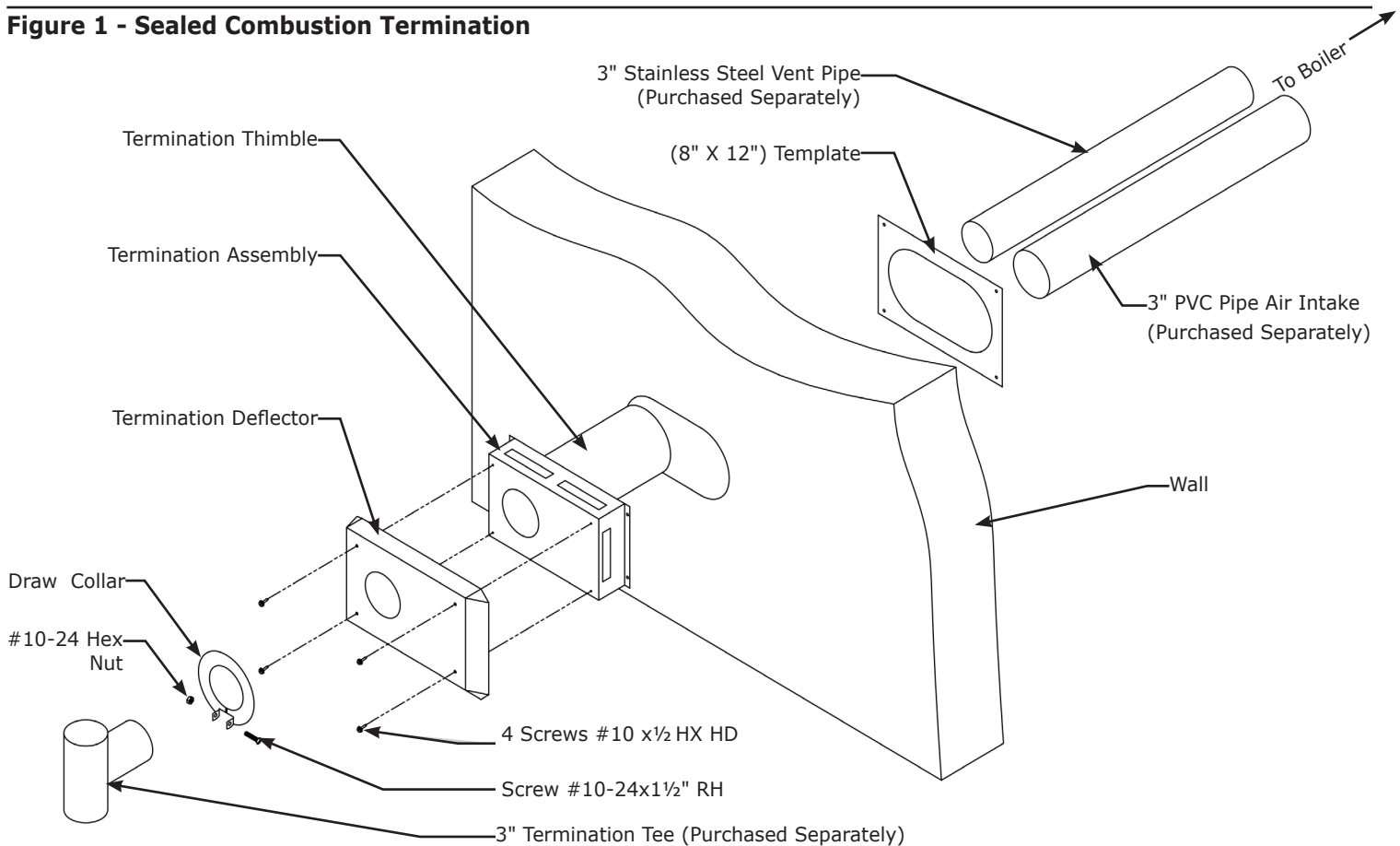

CONTROL BOARD (DBM34A) KIT #FE3980B851

REPLACEMENT INSTRUCTIONS

Kit installation shall be completed by qualified agency.

⚠ WARNING

Fire, explosion, asphyxiation and electrical shock hazard. Improper installation could result in death or serious injury. Read this instruction and understand all requirements, including requirements of authority having jurisdiction, before beginning installation. Installation not complete until appliance operation verified per Installation, Operation & Maintenance Manual provided with boiler.

1. Follow instructions TO TURN OFF GAS TO APPLIANCE found on Operating Instructions label on boiler or in Installation, Operation & Maintenance Manual. Verify all electrical power to boiler is turned off.

⚠ WARNING

Electrical shock hazard. Turn OFF electrical power supply at service panel.

2. Remove front jacket casing per instructions found in Installation, Operation & Maintenance Manual.

⚠ WARNING

Burn hazard. Verify heat exchanger has cooled or use appropriate personal protection equipment.

3. Remove (2) screws on lower part of control housing. See Figure 1.
4. Slide control housing forward. Control housing will fold down on the built in hinge. See Figure 2.
5. Remove two back cover screws.
6. Disconnect all wiring connectors
7. Remove two (2) screws holding board in place. Slide board out. See Figure 3.
8. Replace board and wiring connectors.
9. Replace back cover.
10. Fold control housing up. Slide control housing back into position. Secure with screw.
11. Remove any call for heat or hot water.
12. Turn gas to appliance On following procedure found on boiler or in Installation, Operation & Maintenance Manual.
13. Apply power to boiler.
14. Configure control for proper boiler size and type.

Figure 1

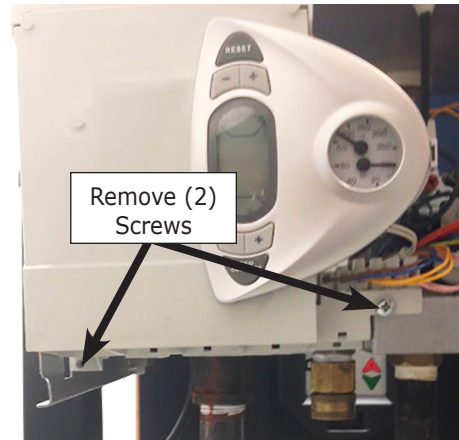

Figure 2

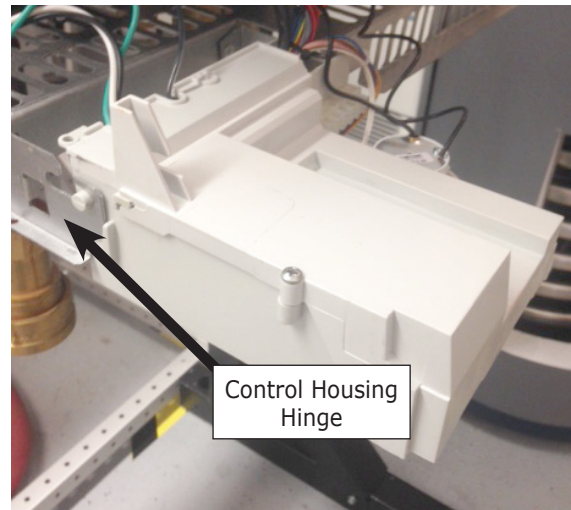
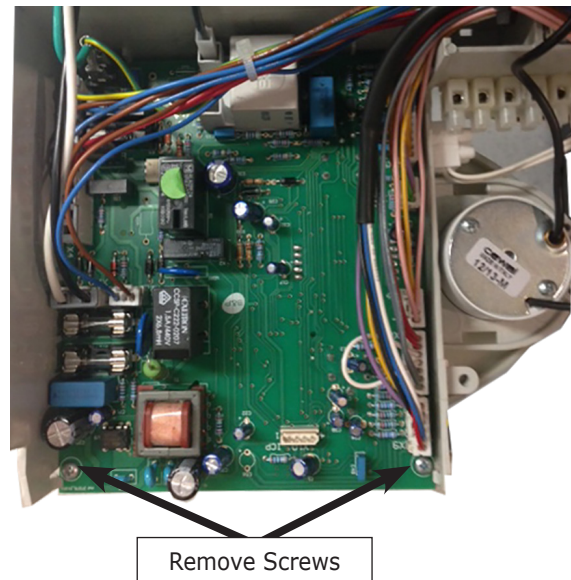

Figure 3



CONTROL BOARD REPLACEMENT INSTRUCTIONS

To access to "tS" parameter:

- Press and hold Reset button for 10 seconds. Display will read "tS". Release button.
- Press Reset button for 1 second. Display will read "P01".
- Press Heating buttons to scroll parameter list. Press DHW buttons to view or change a parameter. Set three (3) parameters "P01", "P02" and "P23" as shown in Table 1 below and Figure 4.

tS Menu		CCB-150	CHB-100	CHB-130	CHB-150
P01	Gas Type	0 = Natural Gas			
		1 = LP Gas			
P02	Boiler Type	1	2	2	2
P23	External CH Pump Control	3	3	3	3

To access Configuration menu:

- Press (DHW) + and - , hold both buttons for 10 seconds; "b01" appears and flashes.
- Press Heating buttons to scroll Configuration list. Press DHW buttons to view or change a setting.
- Change only the Configuration "b01" per Table 2. Remaining parameters are factory defaulted to the correct value, verify value. See Table 3.
- Select proper size, press and hold (DHW) + and - , both buttons for 10 seconds to exit, or turn power off then on, or wait two (2) minutes for auto exit.

15. Replace jacket casing.

16. Verify proper operation by following START UP PROCEDURE in Installation, Operation & Maintenance Manual.

Parameter	Description	Setting
b01	Curve Selection	Default = 2
b01	CHB-100	0
b01	CHB-130	1
b01	CHB-150	2
b01	CCB-150	2

Configuration Menu		CCB-150	CHB-130	CHB-100	CHB-150
b01	Power Selection	2	1	0	2
b02	Offset max. setpoint air signal	0	0	0	0
b03	Burner selection	0	0	0	0
b04	Offset min. setpoint air signal	40	40	40	40

Figure 4

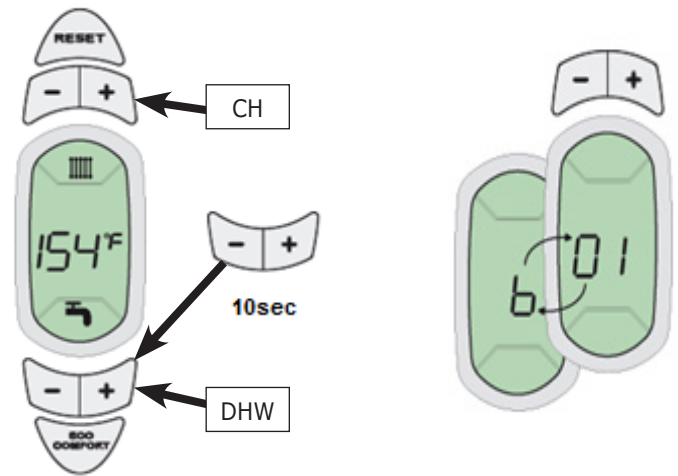

CAUTION

- ▶ DO NOT remove retaining clips on field installed water fittings. Removed fittings CANNOT be reinstalled.
- ▶ DO NOT solder on threaded joints. Heating the fitting will cause O-ring joint failure causing leaks.



RIGHT SIDE CLIP - INSIDE BOILER JACKET



LEFT SIDE CLIP - INSIDE BOILER JACKET

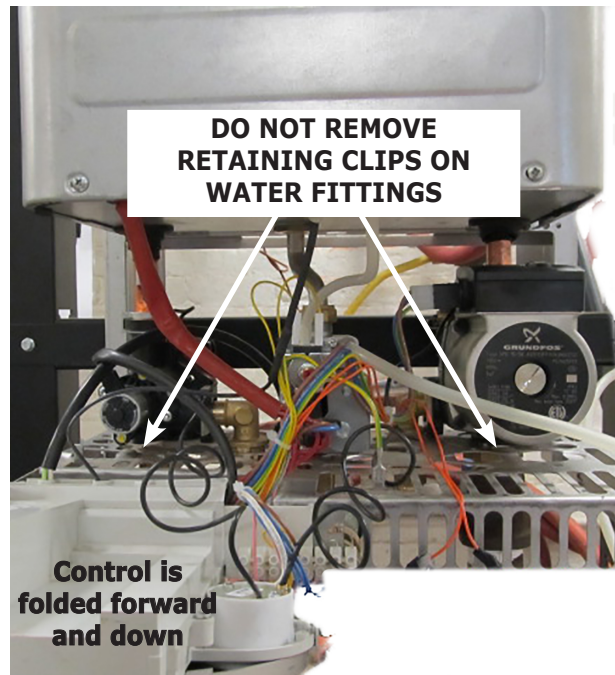

Boiler shown with jacket removed

PN 615000136 REV B, [02/06/2015]

See reverse page for manufacturer recommended piping method. ➡

Manufacturer recommended piping method:

1. Use piping accessories as shown in diagram below.
2. *Do any necessary soldering away from the boiler*, then thread soldered assembly to Boiler connections.

PIPING DIAGRAMS

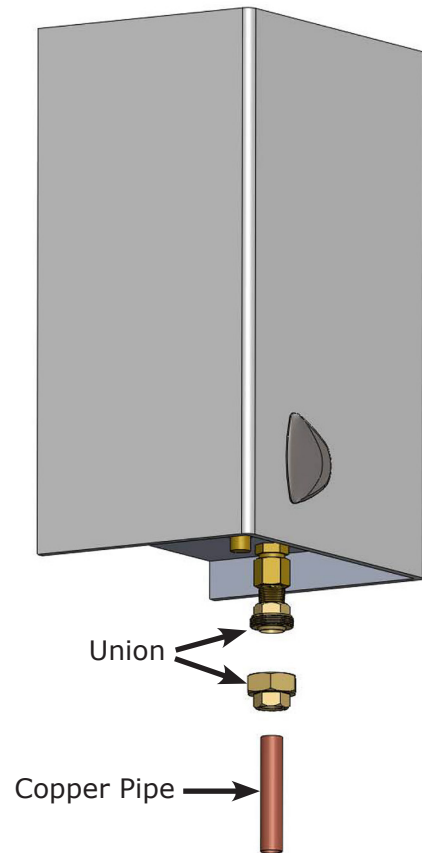
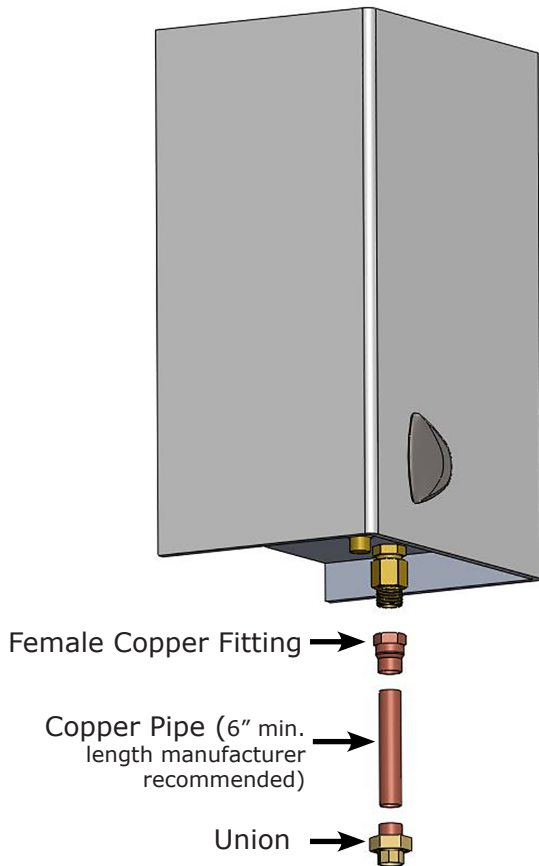

Altitude Affects on CHB-100, CHB-130, CHB 150 and CCB-150

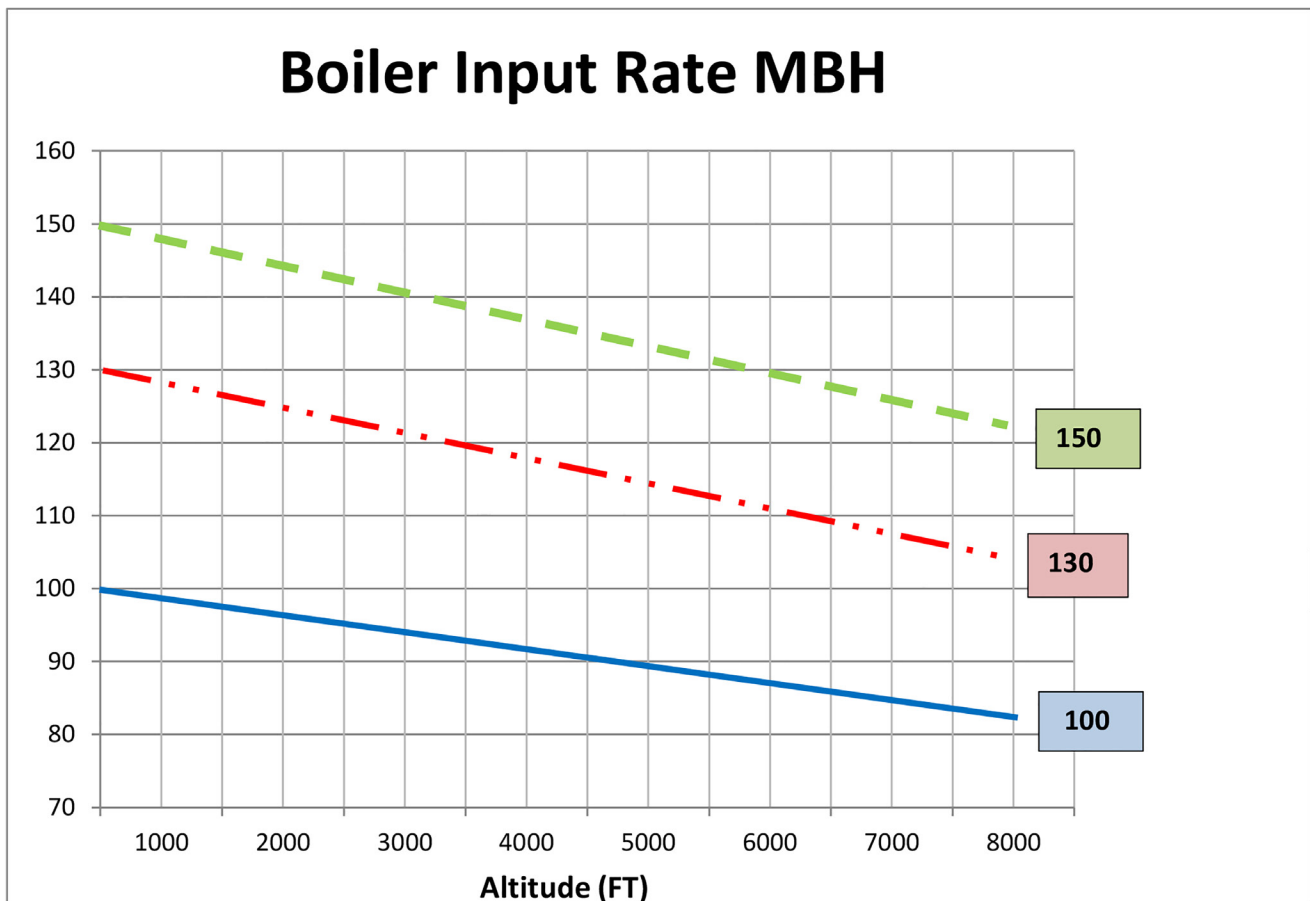

Above curves show affect altitude will have on boiler delivery.

Manufacturer has tested this boiler at altitude (sea level to 8,000 ft.) and determined that standard (ANSI) derate input practices of re-orificing **are not** required for these models.

GAS CONVERSION KIT FOR CCB - CHB BOILER SERIES

⚠ WARNING

Fire, explosion, asphyxiation and electrical shock hazard. Improper installation could result in death or serious injury. Read this instruction and understand all requirements, including requirements of authority having jurisdiction, before beginning installation. Installation not complete until appliance operation verified per Installation, Operation & Maintenance Manual provided with boiler.

GAS CONVERSION KIT CODES AND CONTENT

Conversion to gas type	Kit code	For boiler model	Parts provided in the Kit	Orifice size
NG	FE3980C280	CHB-100	11 x injectors 1.35 11 x aluminum gaskets 1 x conversion label	1.35 mm
LP	FE3980C300	CHB-100	11 x injectors 0.85 11 x aluminum gaskets 1 x conversion label	0.85 mm
NG	FE3980C290	CHB-130	15 x injectors 1.35 15 x aluminum gaskets 1 x conversion label	1.35 mm
LP	FE3980B950	CHB-130	15 x injectors 0.85 15 x aluminum gaskets 1 x conversion label	0.85 mm
NG	FE3980C140	CHB-150 CCB-150	17 x injectors 1.35 17 x aluminum gaskets 1 x conversion label	1.35 mm
LP	FE3980C150	CHB-150 CCB-150	17 x injectors 0.85 17 x aluminum gaskets 1 x conversion label	0.85 mm

CCB-CHB can operate with **Natural Gas or LP gas** and are factory-set for the use with Natural Gas .

To convert boiler to operate with a different type of gas, it is necessary to use the appropriate conversion kit listed in table below and install it as described in this instruction.

INSTRUCTIONS FOR CONVERTING THE BOILER

Follow instructions To **TURN OFF GAS TO APPLIANCE** found on Operating Instructions label on boiler or in Installation, Operation & Maintenance Manual. Verify all electrical power to boiler is turned off.

1. Close the gas cock ahead of the boiler and disconnect the power supply

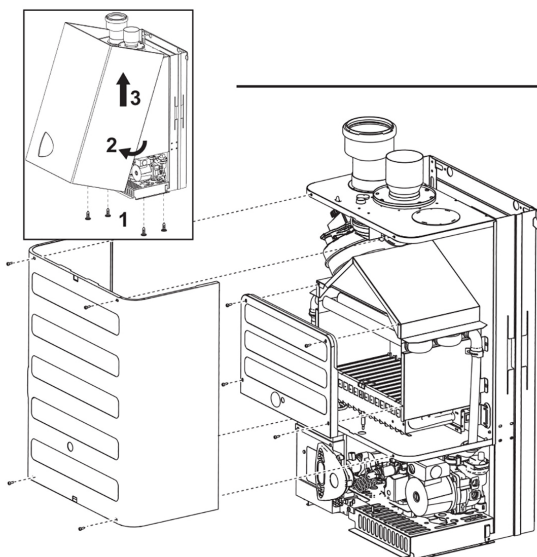

2. Remove boiler jacket and room sealed cover.

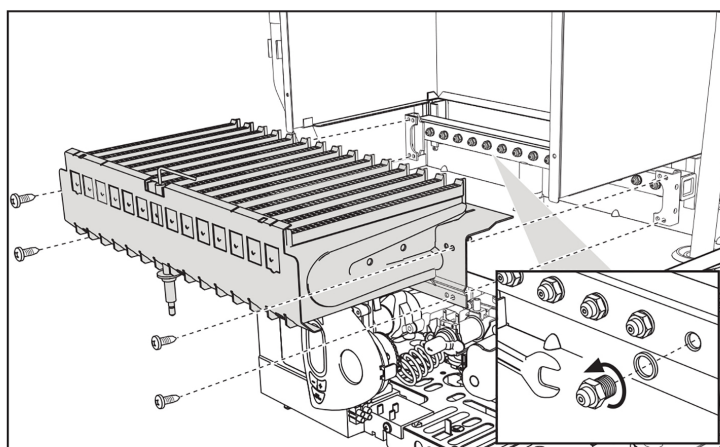

3. Remove burner. **IMPORTANT:** do not disconnect gas collector or gas valve.
4. Remove injectors from gas collector.

5. Verify the proper size of injectors in the conversion kit (ref. table 1) and mount on gas collector, interposing aluminum gaskets. Assure a comp injectors on gaskets.
6. Re-mount burner, room sealed cover and jacket.
7. Connect the power supply ahead of the boiler and open the gas cock; Verify that no gas leakage is occurring.
8. Modify the parameter for the type of gas:
 - Put the boiler in standby mode
 - Press the RESET button for 10 seconds: the display shows "tS" flashing
 - Press the RESET button: the display shows "P01".
 - Press the DHW buttons to set parameter 0 (for natural gas) or 1 (for LP).
 - Press the CH button: the display shows "P02".
 - Press the RESET button for 10 seconds.
 - The boiler will return to standby mode
9. Adjust the correct minimum and maximum burner pressure specified in the table at the end of this document as following:

TEST mode activation

- Press the heating buttons together for 5 seconds to activate the TEST mode. The boiler lights at the maximum heating power set as desc following section.
- The heating and DHW symbols flash on the display; the heating power will appear alongside. (Min.=0%, Max.=100%).
- If the TEST mode is activated and enough hot water is drawn to activate the DHW mode, the boiler remains in TEST mode but the 3-way DHW.
- To deactivate the TEST mode, press the heating buttons together for 5 seconds.
- The TEST mode is automatically deactivated in any case after 15 minutes or on stopping of hot water drawing (if enough hot water has be activate the DHW mode).

Adjustment of pressure at the burner

- Since this unit has flame modulation, there are two fixed pressure values: the minimum and maximum, which must be those given in the t according to the type of gas.
 - Connect a suitable pressure gauge to pressure point "B" located downstream of the gas valve
 - Remove the protection cap "D" undoing screw "A".
 - Operate the boiler in TEST mode.
 - Adjust the power to the max. value.
 - Adjust the max. pressure with screw "G", clockwise to increase the pressure and anticlockwise to decrease it.
 - Disconnect one of the two Faston connectors from the modureg "C" on the gas valve.
 - Adjust the min. pressure with screw "E", clockwise to decrease the pressure and anticlockwise to increase it.
 - Reconnect the Faston connector detached from the modureg on the gas valve.
 - Check that the maximum pressure has not changed.
 - Refit protection cap "D".
 - To end the TEST mode repeat the activation sequence or wait 15 minutes.
10. Fill the label contained in the conversion kit and apply near the dataplate as proof of the conversion.

After checking or adjusting the pressure, make sure to seal the adjustment screw with paint or a specific seal.

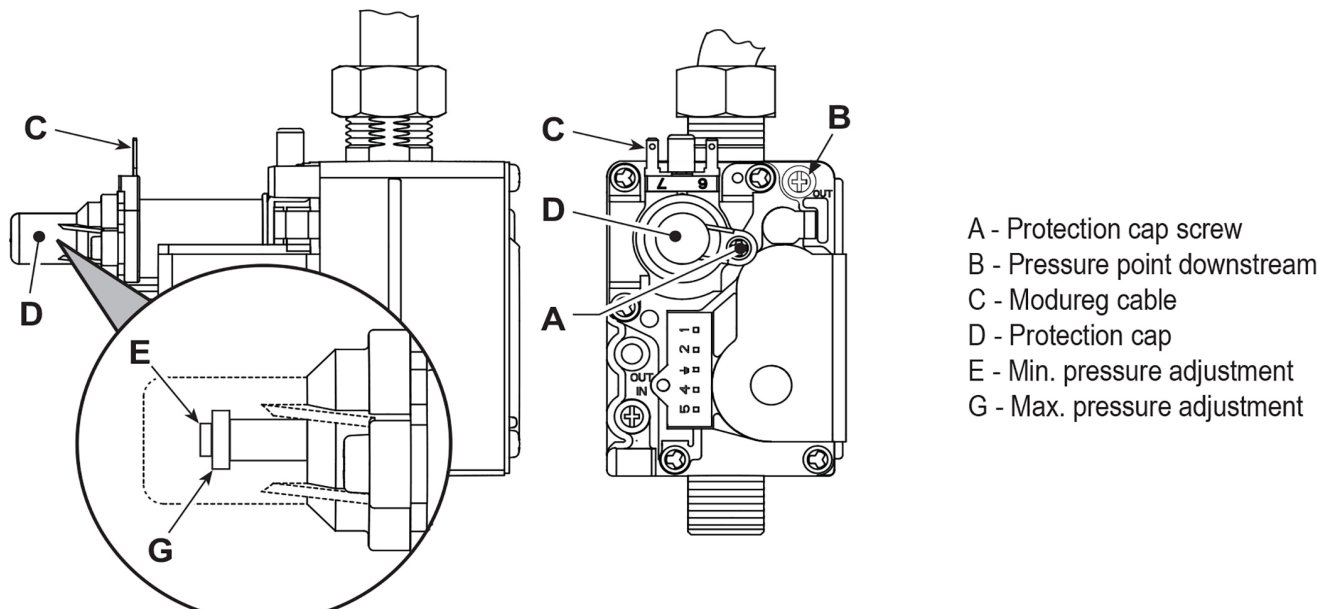

BOILER MODEL		CHB-100	CHB-130	CHB-150	CCB-150
Orifice Natural Gas	n°xØ mm	11 x 1.35	15 x 1.35	17 x 1.35	17 x 1.35
Min - Max Burner pressure Natural Gas	"w.c.	0.6 – 5.22	0.6 – 4.82	0.6 – 5.22	0.6 – 5.22
Nominal Supply pressure Natural Gas	"w.c.	7.9	7.9	7.9	7.9
Orifice Propane	n°xØ mm	11 x 0.85	15 x 0.85	17 x 0.85	17 x 0.85
Min - Max Burner pressure propane	"w.c.	1.6 - 10	1.6 - 10	1.6 - 10	1.6 - 10
Nominal Supply pressure propane	"w.c.	11	11	11	11

CHB BOILER

DHW RESISTOR HARNESS AND RELAY

KIT 550003082

For use with Argo ARM Zone Pump Control

Kit installation shall be completed by qualified agency.

WARNING
<p>Fire, explosion, asphyxiation and electrical shock hazard. Improper installation could result in death or serious injury. Read this instruction and understand all requirements, including requirements of authority having jurisdiction, before beginning installation. Installation not complete until appliance operation verified per Installation, Operation & Maintenance Manual provided with boiler.</p>

1. Follow instructions TO TURN OFF GAS TO APPLIANCE found on Operating Instructions label on boiler or in Installation, Operation & Maintenance Manual. Verify all electrical power to boiler is turned off.

WARNING
<p>Electrical shock hazard. Turn OFF electrical power supply at service panel.</p>

2. Verify all power to boiler is turned OFF at service panel.
3. Follow Installation, Operation & Maintenance manual to remove front jacket panel

WARNING
<p>Burn hazard. Verify heat exchanger has cooled or use appropriate personal protection equipment.</p>

4. Inspect combustion chamber through sight glass. Verify flame is not present.
5. See wiring shown in figures 2 and 3.

Kit Contents:	
Description	Qty.
DHW Resistor Harness	1
Isolation Relay (24 VAC)	1
Wire Nuts	7
Installation Instructions	1

Use this kit when the following applies:

- Use of Argo ARM Zone Control.
- Multiple 'CH' Zone and priority 'DHW' operation is required.
- Indirect tank operation (DHW) is controlled using mechanical thermostat.

If any of the conditions above apply:

- a. Use piping diagram Figure 4 attached.
- b. Priority switch on Argo Zone Control must be set to "ON" position.
- c. Must use anti-scald valve on domestic hot water supply piping.

CHB BOILER - DHW RESISTOR HARNESS KIT

Multi-Zone Pump System with DHW Tank Thermostat and Isolation Relay

If DHW tank thermostat is applied to multi-zoned pump application secondary pump operation is controlled by Argo priority switch position.

FIGURE 1 - Isolation Relay

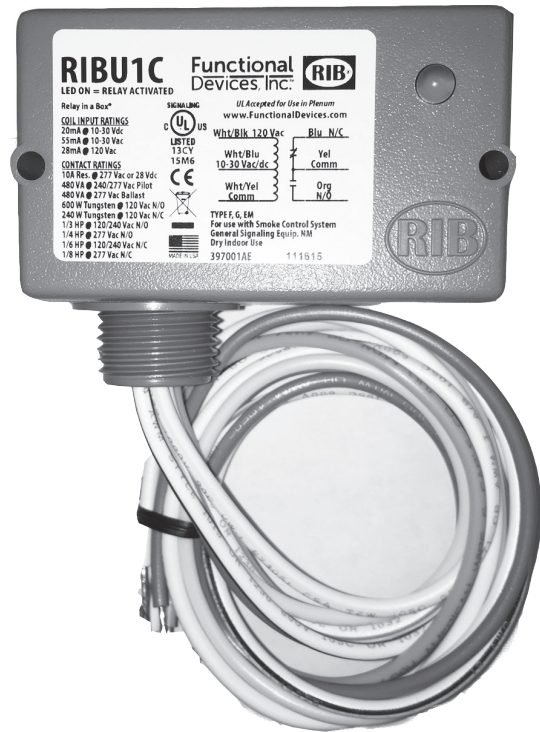

NOTICE

Important:

- Before connecting to Key72 terminals, remove jumper on terminal block.
 - Before connecting Low Water Cut-off remove jumper on terminal block. (Key 370)
1. Boiler thermostat contacts (KEY 72) are wired to Argo ARM Zone Pump Control terminals (x-x). Zone thermostats and zone pumps are also wired to Argo Controller as shown on wiring diagram. See figure 2.
 2. Important - Remove factory installed resistors, Terminal 7 and 8 on terminal strip (KEY 155).
 3. Attach resistor kit wire harness to terminal strip (White wire to #7 / Red wire to #8). See figures 2 and 3.

NOTICE

Failure to observe wire coding will result in improper boiler operation. See wiring diagram figure 2.

4. Attach isolation relay provided to Argo Zone Control using an electrical knockout. Secure using conduit nut. See figure 1.
5. Extend brown and blue wires of wire harness to normally closed (N.C.) contacts on isolation relay (blue and yellow wires). Secure unused wire end of relay contact (ORG-N.O.) using provided wire nut.
6. Attach isolation relay coil wiring (24 VAC) to Argo Controller. Connect White/Blue wire to Argo zone 1 (Tw) and white/yellow wire to Argo "Common". see figure 2. Secure unused wire end of relay coil, 120V-white/black using wire nut provided.
7. Wire DHW mechanical tank thermostat to Priority Zone (Tw/Tr) contacts on Argo Zone Control.
8. Important: Set Argo Priority Switch to:
 - a. **ON** position - CH pumps **WILL** shutoff during DHW priority.
 - b. **Do not operate** this system with the Argo Priority Switch in **OFF** position.

NOTICE

If Indirect Tank pump is used connect to Priority Zone terminals (L1/N1) on Argo Controller.

9. Restore gas service and electrical power. Follow lighting and operating instructions. Restart boiler. Verify proper operation by following START UP Procedure found in boiler's Installation, Operation and Maintenance Manual.

CHB BOILER - DHW RESISTOR HARNESS KIT

FIGURE 2 - CHB Boiler WITH SECONDARY ZONE PUMPS and DHW THERMOSTAT

NOTE: ZONE PUMPS WILL SHUTOFF DURING DHW PRIORITY W/ PRIORITY SWITCH ON

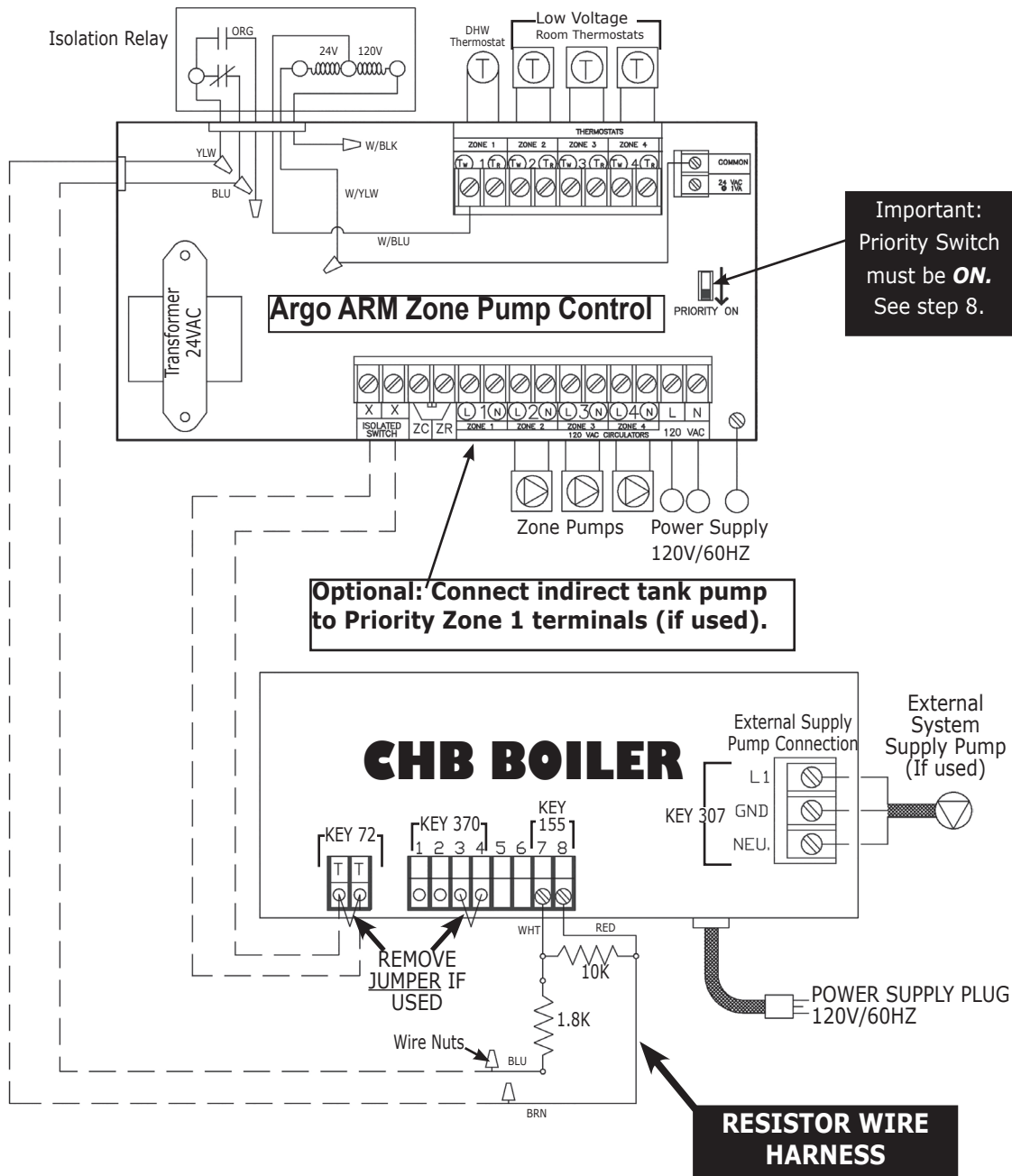
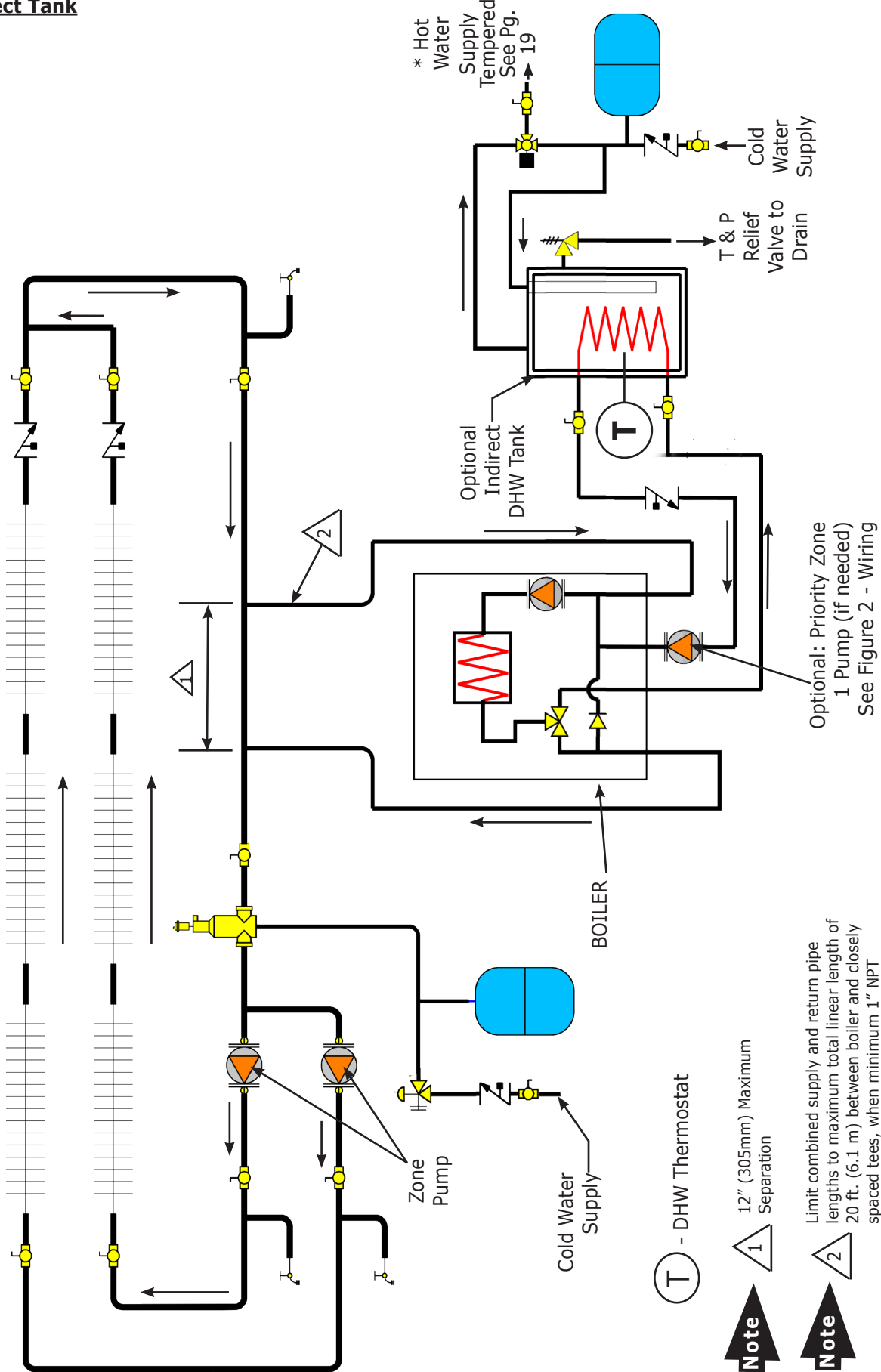

FIGURE 3 - Resistor Wire Kit Harness (DHW)



CHB BOILER - DHW RESISTOR HARNESS KIT

FIGURE 4 - CHB -Single Boiler Primary/Secondary Series Loop Zoned WITH ZONE PUMPS and Optional Indirect Tank



Note  12" (305mm) Maximum Separation

Note  Limit combined supply and return pipe lengths to maximum total linear length of 20 ft. (6.1 m) between boiler and closely spaced tees, when minimum 1" NPT pipe size is used. Linear length may be increased if supply and return pipe size is increased to limit pressure drop

Note * Manufacturer requires all domestic hot water (DHW) installations use an anti-scaled valve. Local codes may require additional equipment (expansion tank, relief valves, etc.) Select and size equipment to suit installation and meet code requirements.

See CHB/CCB Applications Guide located on the web at www.ecrinternational.com for indirect tank applications using boiler's on-board pump refer to flow rate and available pump head curves. Refer to Boiler's Installation, Operation and Maintenance Manual for operational requirements. Consult indirect tank manufacturer for indirect tank performance.

CCB/CHB REPLACEMENT COMBUSTION COVER KIT INSTRUCTIONS

550003447 - CCB/CHB 150 550003448 - CHB 100 550003449 - CHB 130

Kit installation shall be completed by qualified agency.

⚠ WARNING

Fire, explosion, asphyxiation and electrical shock hazard. Improper installation could result in death or serious injury. Read these instructions and understand all requirements, including requirements of authority having jurisdiction, before beginning installation. Installation not complete until appliance operation is verified per Installation, Operation & Maintenance Manual provided with boiler.

⚠ CAUTION

Laceration, burn hazard. Metal edges and parts may have sharp edges and/or may be hot. Use appropriate personal protection equipment to include safety glasses and gloves when installing or servicing this appliance. Failure to follow these instructions could result in minor or moderate injury.

Combustion Cover Replacement

1. Follow instructions To TURN OFF GAS TO APPLIANCE found on Operating Instructions label on boiler or in Installation, Operation & Maintenance Manual. Verify all electrical power to boiler is turned off.

⚠ WARNING

Electrical shock hazard. Turn OFF electrical power supply at service panel.

2. Verify all power to boiler is turned OFF at service panel.
3. Follow Installation, Operation & Maintenance manual to remove front jacket panel.

⚠ WARNING

Burn hazard. Verify unit has cooled before servicing. Use appropriate personal protection equipment.

4. Inspect combustion chamber through sight glass. Verify flame is not present.
5. Verify unit has cooled before servicing.
6. Remove (4) four screws from external heat exchanger cover. See Figure 1. Lift cover up from bottom and pull forward.
7. Remove (4) four screws holding inner combustion cover with insulation.
8. Install new inner combustion cover and insulation in place. Secure with 4 screws.

9. Install new outer combustion cover in place. Take care to ensure left and right sides are tucked behind the vertical rails. Secure with 4 screws.
10. Turn Gas and Electric to boiler on.
11. Resume operation using OPERATING INSTRUCTIONS found on Operating Instructions label on boiler or in Installation, Operation & Maintenance Manual.
12. Install front panel. Secure in place with removed screws.
13. Verify proper operation.

Figure 1 - Heat Exchanger Covers

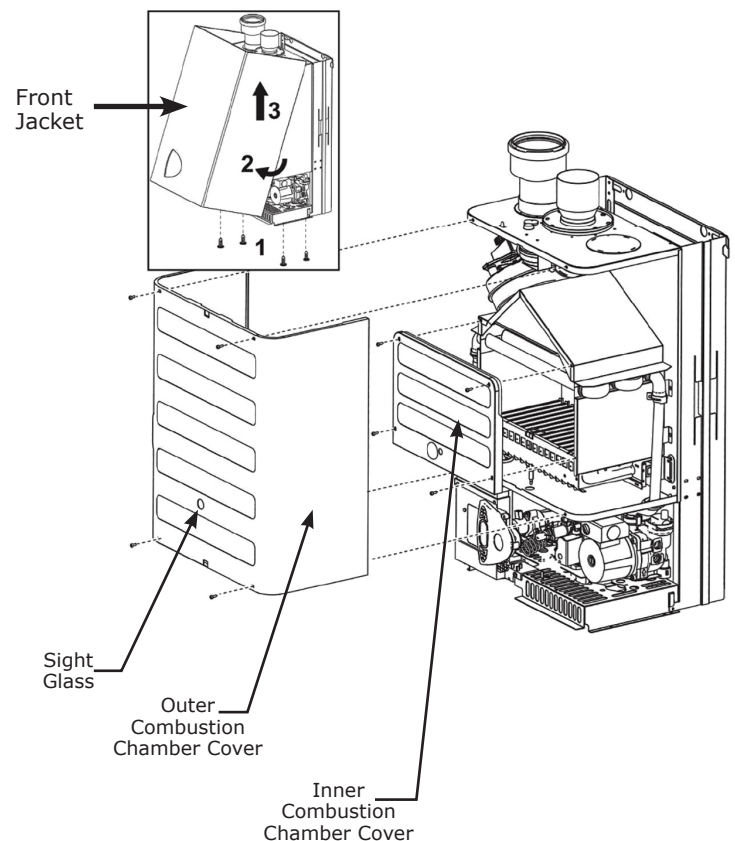

Illustrations are a depiction of the boiler for general location of parts and are subject to change without notice.



ECR International Inc. 2201 Dwyer Avenue, Utica, NY 13501
Tel. 800 253 7900
www.ecrinternational.com

All specifications subject to change without notice.
©2017 ECR International, Inc.
PN 240012041 REV. A [11/30/2017]