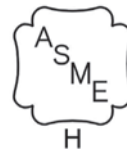




CONDENSING GAS FIRED  
FLOOR OR WALL MOUNTED  
BOILER




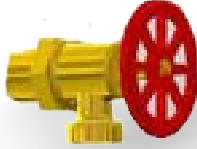


INSTALLATION, OPERATION &  
MAINTENANCE MANUAL

Model  
DMG-380



Manufactured by:  
ECR International Inc.  
2201 Dwyer Avenue, Utica, NY 13501  
Tel. 800 325 5479  
[www.ecrinternational.com](http://www.ecrinternational.com)  
PN 240011664 REV. L [11/01/2020]

**VERIFY CONTENTS RECEIVED**

			
<p><b>Fully Assembled Boiler</b></p>	<p><b>Safety Relief Valve</b></p>	<p><b>Temperature Pressure Gauge</b></p>	<p><b>Drain Valve</b></p>
	<p>Used for measuring outside temperature</p>	<p>Includes essential documents</p>	
<p><b>Gas Shutoff Valve</b></p>	<p><b>Outdoor Sensor</b></p>	<p><b>Document Package</b></p>	<p><b>Manifold (See page 13 5.8 for install instructions)</b></p>

For Parts lists see manual included with your boiler literature package.

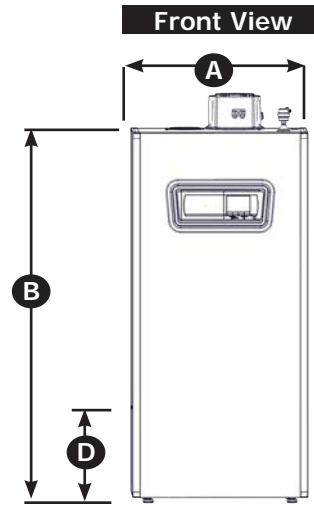
## TABLE OF CONTENTS

<b>1 - Important Information.....</b>	<b>5</b>	9.8 Before Gas Conversion .....	51
<b>2 - Introduction.....</b>	<b>6</b>	9.9 Gas Conversion (Propane) .....	51
<b>3 - Component Listing .....</b>	<b>7</b>	9.11 Combustion Setup (Low-Fire) .....	52
<b>4 - Locating Boiler .....</b>	<b>8</b>	9.12 Operational Check.....	52
<b>5 - Hydronic Piping.....</b>	<b>10</b>	9.10 Combustion Setup (High-Fire) .....	52
5.1 General.....	10	9.13 User Level Parameters.....	53
5.2 Special Conditions .....	10	9.14 Installer Level Parameters.....	53
5.3 Safety Relief Valve And Air Vent.....	11	9.15 Parameters Settings.....	54
5.4 Low Water Cutoff .....	11	9.16 Reading Measured Values.....	57
5.5 Trim Piping .....	12	9.17 Status And Sub-Status .....	58
5.6 System Piping .....	12	9.18 Return To The Factory Settings: .....	59
5.7 Heating System And Refrigeration.....	13	<b>10 - Operating Instructions.....</b>	<b>60</b>
5.8 Labor Saver Manifold Installation (Supplied) .....	13	10.1 Sequence Of Operation.....	60
<b>6 - Combustion Air And Vent Piping.....</b>	<b>17</b>	10.2 Operating Instructions.....	60
6.1 General.....	17	10.3 To Turn Off Gas To Appliance .....	60
6.2 Removal Of Existing Boiler From Common Vent System	17	<b>11 - General Maintenance And Cleaning .....</b>	<b>61</b>
6.3 Definitions.....	18	11.1 Beginning Of Each Heating Season .....	61
6.4 Approved Venting Materials.....	19	11.2 Annual Shut Down Procedure .....	62
6.5 Coaxial.....	19	11.3 Annual Inspection And Cleaning Of Boiler Components	62
6.6 Twin Pipe Polypropylene And Cpvc Systems.....	21	11.4 Maintenance And Routine Servicing .....	63
6.7 Twin Pipe Spring Clamp Instructions.....	21	11.5 Component Replacement And Cleaning .....	63
6.8 Venting Configurations .....	23	11.6 Draining The Boiler .....	64
6.9 Side Venting Terminal Requirements .....	27	<b>12 - Ratings And Capacities.....</b>	<b>65</b>
6.10 Multiple Boiler Venting - General .....	30	<b>13 - Trouble Shooting.....</b>	<b>66</b>
6.11 Multiple Boiler Venting - Mounting Procedure ...	30	13.1 Troubleshooting.....	66
6.12 Multiple Boiler Venting - Venting Layout.....	32	13.2 Shutdowns And Lock-Outs.....	68
6.13 Multiple Boiler Venting - Parameter Settings .....	34	13.3 Error History .....	71
6.14 Condensate Piping .....	35	13.4 Error History Readout.....	71
<b>7 - Gas Supply Piping .....</b>	<b>36</b>	13.5 Optional Sensors .....	72
7.1 General.....	36	Troubleshooting Chart 1.....	73
7.2 Lp Conversion .....	36	Troubleshooting Chart 2.....	74
7.3 Leak Check Gas Piping .....	37	Troubleshooting Chart 3.....	75
<b>8 - Electrical Connections .....</b>	<b>38</b>	Troubleshooting Chart 4.....	76
8.1 General.....	38	Troubleshooting Chart 5.....	77
8.2 Electric Knockouts .....	38	Troubleshooting Chart 6.....	78
8.3 Electrical Connections .....	38	Troubleshooting Chart 7.....	79
8.4 Access To Connection Block.....	39	Troubleshooting Chart 8.....	79
8.5 Main Supply Connection .....	39	Troubleshooting Chart 9.....	80
8.6 Shutdown Input .....	40	Troubleshooting Chart 10.....	81
8.7 Release Input.....	40	Troubleshooting Chart 11.....	82
8.8 Optional Electrical Connections: .....	40	Temperature-Resistance Chart .....	83
8.9 K Ohm (1k $\Omega$ ) Outdoor Temperature Sensor .....	43	<b>14 - Glossary.....</b>	<b>84</b>
8.10 Central Heating Thermostat .....	43		
8.11 10 K $\Omega$ DhW Indirect Water Heater .....	44		
8.12 Frost Protection .....	44		
8.13 Pump Anti-Seize Protection .....	44		
<b>9 - Start Up Procedure.....</b>	<b>47</b>		
9.1 Fill Condensate Trap With Water .....	47		
9.2 Commission Setup (Water) .....	47		
9.3 Commission Setup (Gas) .....	48		
9.4 Commission Setup (Electric) .....	48		
9.5 Control Panel.....	49		
9.6 Deaeration Function.....	50		
9.7 Commissioning.....	51		

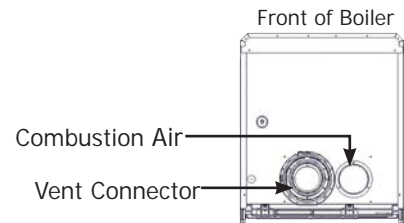
Dimensions

Table 1: Physical Data		
Model	380	
Width (A)	23-5/8" (600mm)	
Height (B)	50" (1.27m)	
Depth (C)	25-1/2" (648mm)	
Bottom Cabinet (D) Access from Back or Sides of Jacket	11-3/4" (298.5mm)	
Water Connections	Size	1-1/2" (38.1mm)
	Location (G)	3-3/4" (95.3mm)
	Location (H) Return	11-3/4" (298.5mm)
	Location (I) Supply	7-3/4" (196.9mm)
Gas Connection	Location (L)	7-3/4" (196.9mm)
	Size	1" NPT
Condensate Drain Connection (J)	Location (J)	8-3/4" (196.9mm)
	Size	3/4" NPT
Weight	Shipping	255 LBS (115.7)
	Unit	225 LBS (102.1kg)
Vent Connector - Concentric	110/160 mm	
Electrical Cord Length	5 ft. (1.5m)	

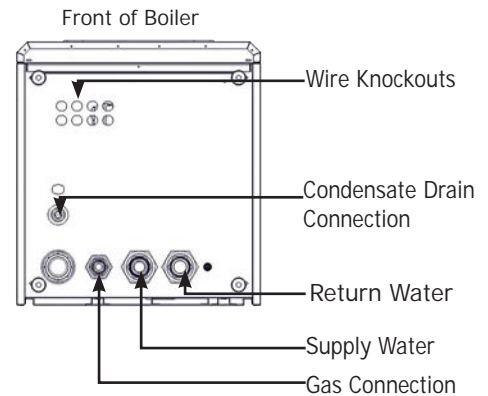
50 psi safety relief valve (3.44 bar)  
 Pressure relief valve connection 3/4"  
 (22.2mm)



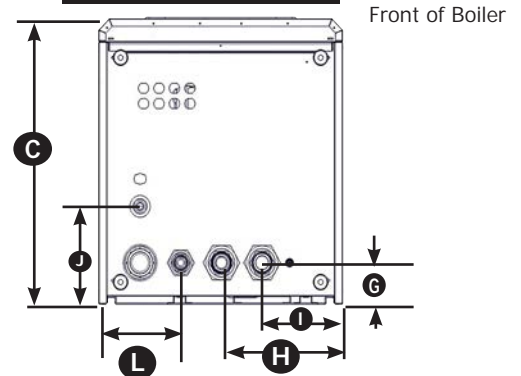
Top View



Bottom View Connection Identification



Bottom View Dimensions



# 1 - IMPORTANT INFORMATION

## 1. Safety Information

Boiler installation shall be completed by qualified agency. See glossary for additional information.

### WARNING

Fire, explosion, asphyxiation and electrical shock hazard. Improper installation could result in death or serious injury. Read this manual and understand all requirements before beginning installation.

### WARNING

Do not tamper with or use this boiler for any purpose other than its intended use. Failure to follow these instructions could result in death or serious injury. Use only manufacturer recommended parts and accessories.


### WARNING

Fire, Explosion, Asphyxiation, Electrical shock hazard! Flooding will result in damages such as electrical problems, corrosion, inoperative parts, mold and other unforeseen issues which can occur over time. Any equipment determined by a professional as damaged by a flood, defined as excess of water or other liquid, shall be replaced. Failure to follow these directions will result in a Hazardous Situation.

### CAUTION

Laceration, burn hazard. Metal edges and parts may have sharp edges and/or may be hot. Use appropriate personal protection equipment to include safety glasses and gloves when installing or servicing this boiler. Failure to follow these instructions could result in minor or moderate injury.

Become familiar with symbols identifying potential hazards.

 This is the safety alert symbol. Symbol alerts you to potential personal injury hazards. Obey all safety messages following this symbol to avoid possible injury or death.

### DANGER


Indicates a hazardous situation which, if not avoided, WILL result in death or serious injury.

### WARNING

Indicates a hazardous situation which, if not avoided, could result in death or serious injury.

### CAUTION

Indicates a hazardous situation which, if not avoided, could result in minor or moderate injury.

 Used to address practices not related to personal injury.

## FOR YOUR SAFETY READ BEFORE OPERATING

# DANGER



### Hot Water Can Scald!

Water heated to temperature for clothes washing, dish washing and other sanitizing needs can scald and cause permanent injury.

Children, elderly, and infirm or physically handicapped persons are more likely to be permanently injured by hot water. Never leave them unattended in bathtub or shower. Never allow small children to use a hot water tap or draw their own bath.

If anyone using hot water in the building fits the above description, or if state laws or local codes require certain water temperatures at hot water taps, you must take special precautions:

- Use lowest possible temperature setting.
- Install some type of tempering device, such as an automatic mixing valve, at hot water tap or water heater. Automatic mixing valve must be selected and installed according to manufacturer's recommendations and instructions.
- Water passing out of drain valves may be extremely hot. To avoid injury:
  - Make sure all connections are tight.
  - Direct water flow away from any person.

Water Temperature Setting	1st Degree Burn Exposure Time For An Adult	2nd and 3rd Degree Burn Exposure Time For An Adult
120° F	1 minute	5 minutes
130° F	5 seconds	30 seconds
140° F	2 seconds	5 seconds
150° F	1 second	1.5 seconds
160° F	Instantaneous	0.5 seconds

**Note:** Warning for Infants, Children, and Elderly: Great care must be taken when exposing the aforementioned groups to warm or hot water as they can be badly burned in exposure times less than half of the time for an adult.

## 2 - INTRODUCTION

### 2 - Introduction

**2.1** Installation shall conform to requirements of authority having jurisdiction or in absence of such requirements:

- United States

- National Fuel Gas Code, ANSI Z223.1/NFPA 54.
- National Electrical Code, NFPA 70.

**2.2** Where required by authority having jurisdiction, installation shall conform to Standard for Controls and Safety Devices for Automatically Fired Boilers, ANSI/ASME CSD-1. Additional manual reset low water cutoff may be required.

**2.3 Requirements for Commonwealth of Massachusetts:**

Boiler installation must conform to Commonwealth of Massachusetts code 248 CMR which includes but is not limited to:

Installation by licensed plumber or gas fitter.

**2.4 Manufacturer recommends use of Carbon Monoxide monitor may be requirement of local jurisdiction.**

### 2.5 Designated Use

- Hot water heating boiler.
- Indoor installation.
- Closet or alcove installation.
- Direct vent boiler or single vent pipe.
- For use with natural gas or liquefied petroleum gases (LP/propane).

### 2.6 The unit **MUST NOT**:

- Directly heat potable water. Indirect heating is acceptable.
- Heat water with non-hydronic heating system chemicals present (example, swimming pool water).
- Exceed 50 psig (3.44 bar) maximum allowable working pressure, or drop below minimum system pressure 7.25 psig (.50 bar)
- Exceed 176°F (80°C) system design temperature.

### 2.7 Operational Features

- Modulating: 10:1 ratio.
- Integral Dual Limit.
- Integral Low Water Pressure Cutoff.
- Outdoor Temperature Reset.
- Heat exchanger over heat protection.
- Recommended system pressure (cold) 21.7 psig (1.5 bar)

### 2.8 CSD-1 Compliance

Consult authority having jurisdiction prior to installation.

Field source:

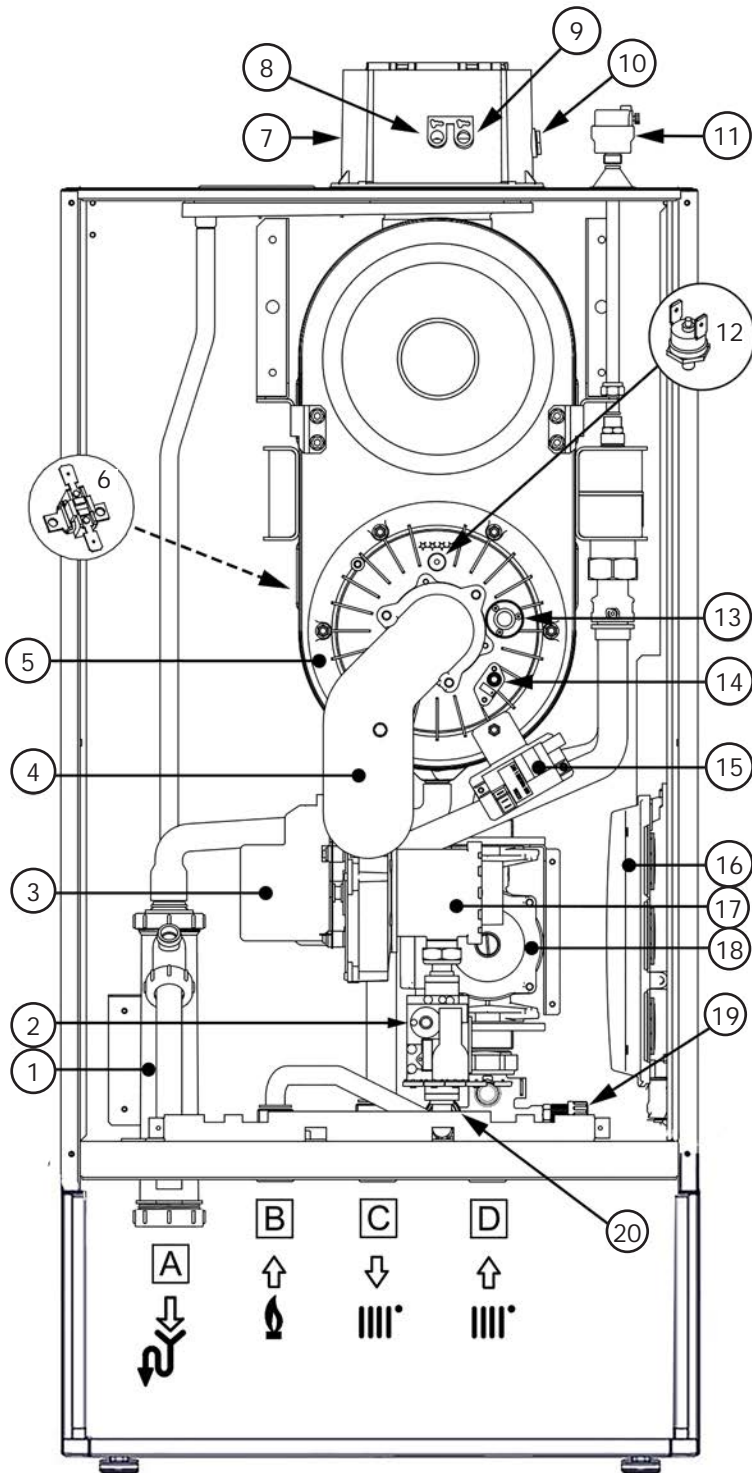
- Manual reset low water cutoff. See Section 5-4.
- Manual Reset External High Temperature Limit.

Check our website frequently for updates: [www.ecrinternational.com](http://www.ecrinternational.com)

**Information and specifications outlined in this manual in effect at the time of printing of this man ECR International reserves the right to discontinue, change specifications or system design at any time without notice and without incurring any obligation, whatsoever.**

### 3 - COMPONENT LISTING

DMG-380



1	Condensate trap
2	Gas Valve
3	Fan
4	Air/gas mixer
5	Heat exchanger
6	Thermal fuse (#6 on wire diagram)
7	Coaxial flue connector
8	Exhaust test port
9	Intake test port
10	Flue sensor
11	Automatic air vent
12	Exchanger flange high limit (#4 on wire diagram)
13	Burner sight glass
14	Ignition/Flame detection electrode
15	Spark generator
16	Auxiliary control board box
17	Air/gas venturi
18	Pump
19	Boiler drain
20	Low water pressure switch
A	Condensate trap drain
B	Gas inlet connection
C	Heating supply connection
D	Heating return connection

## 4 - LOCATING BOILER

### ⚠ WARNING

Fire Hazard! Do not install on carpeting. Failure to follow these instructions could result in death or serious injury.

#### 4.1 Boiler Location Considerations

- Ambient room temperature always above 32°F (0°C) to prevent freezing of liquid condensate.
- Approved for installation in closets or alcove provided it is correctly designed for that purpose.
- Not approved for outdoor installation.
- Protect gas ignition system components from water (dripping, spraying, rain, etc.) during operation and service (circulator replacement, condensate trap, control replacement, etc.).
- Access to outdoors to meet minimum and maximum pipe lengths for combustion air and vent piping. See section 6.
- Disposal of condensate. See section 6.
- Drainage of water (or water - antifreeze solution) during boiler service or from safety relief valve discharge. See section 5.
- Access to system water piping, gas supply, and electrical service. See sections 5, 7 and 8.
- Clearances to combustible materials and service clearances. See Table 2 and figures 4-1a - 4-2c.
- Boiler shall be installed on flat surface, capable of supporting the weight of the boiler.
- Do not install on carpet.
- Boiler may be installed in any room or internal space, special attention shall be given to the requirements of the current electrical provisions with respect to the installation of the boiler in a room or internal space containing a bath or shower. Where a room- sealed boiler is installed in a room containing a bath or shower, it must not be possible for a person using the bath or shower to touch any electrical switch or boiler control utilizing line voltage electricity.
- Multiple Boilers can be placed side by side, or back to back.

**TABLE 2: BOILER CLEARANCES**

Dimension	Combustible Materials <sup>(1)</sup>	Service <sup>(1)(2)</sup>
<b>Model</b>	<b>DMG - 380</b>	
Top (A)	0" (0 mm)	15-3/4 (400 mm)
Left Side (B)	1-3/4" (45 mm)	1-3/4" (45 mm)
Right Side (C)	1-3/4" (45 mm)	1-3/4" (45 mm)
Front (D)	1-3/4" (45 mm)	17-3/4" (450 mm)
Back (E)	0" (0 mm)	0" (0 mm)
Bottom (F)	0" (0 mm)	0" (0 mm)
Combustion Air/Vent piping	0" (0 mm)	6" (160 mm)

<sup>(1)</sup> Required distances measured from boiler jacket.

<sup>(2)</sup> Service, proper operation clearance recommendation.

\* Allowance for piping at the bottom of boiler not included.



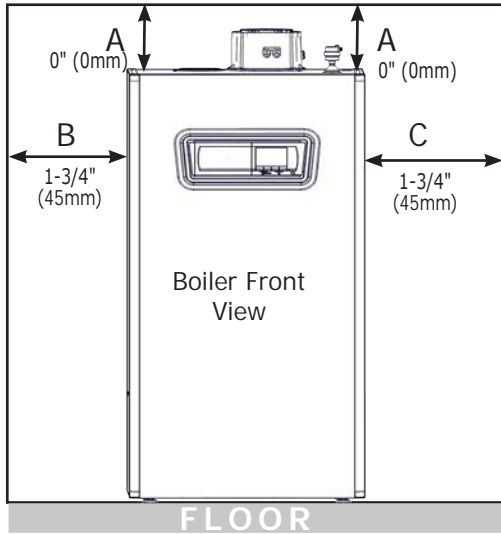
Use two (2) wrenches when tightening and fitting to pipe boiler's threaded fittings. Boiler's internal piping can be damaged if subjected to excessive torque.



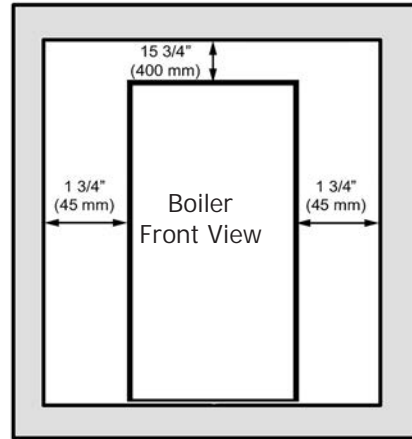
## 4 - LOCATING BOILER

**FIGURE 4-1a Clearance to Combustible Materials**

(See Table 2, page 8)



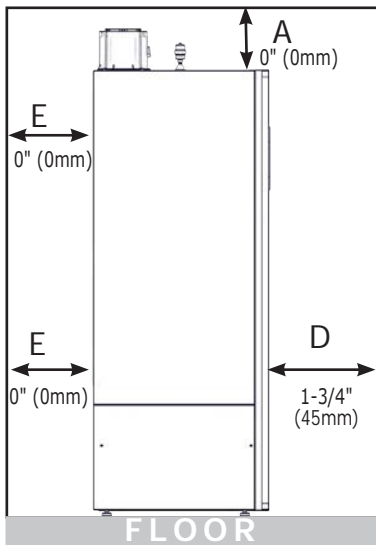
**FIGURE 4-2a Service Clearances - Boiler Front View**



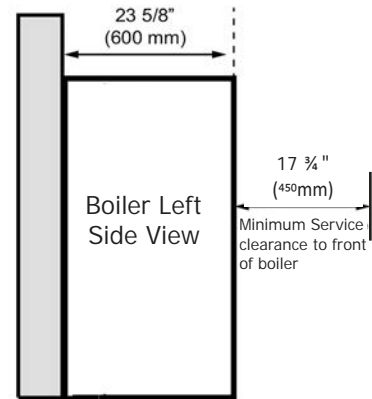
**FIGURE 4-1b Clearance to Combustible Materials**

(See Table 2, page 8)

Boiler Left Side View

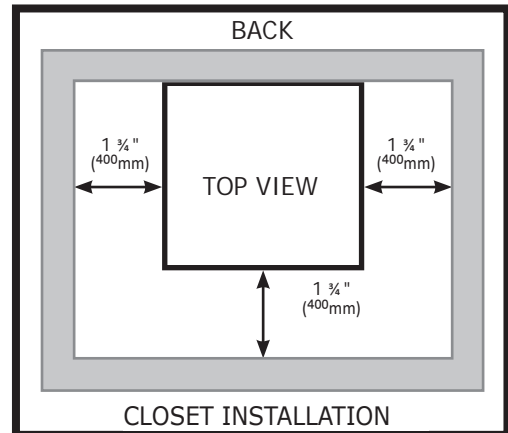


**FIGURE 4-2b Service Clearances - Boiler Left Side View**



**FIGURE 4-2c Combustible Clearances - Closet Installation**

**CLEARANCES REQUIRED FOR CLOSET INSTALLATION**



0 in. / 0 mm between the Back of the Unit and the wall

**Note** Boiler rated at 80 psig (551.6 kPa) maximum allowable working pressure. Boiler provided with 50 psig (345 kPa) safety relief valve. Field source safety relief valves for system pressures greater than 50 psig (345 kPa).

**Note** When installing safety relief valve it must be installed in a vertical position with spindle at top.

### ⚠ WARNING

- Poison hazard. Ethylene glycol is toxic. Do not use ethylene glycol.
- Never use automotive or standard glycol antifreeze, even ethylene glycol made for hydronic systems.
- Ethylene glycol can attack gaskets and seals used in hydronic systems.
- Do not use petroleum based cleaning or sealing compounds boiler system.
- Do not fill boiler or boiler system with softened water.
- Use only inhibited propylene glycol solutions certified by fluid manufacturer as acceptable for use with closed water heating system.
- Thoroughly clean and flush any system that used glycol before installing new Boiler.
- Provide user with Material Safety Data Sheet (MSDS) on fluid used.

### 5.1 General

- Primary/Secondary piping required.
- Install piping in accordance with authority having jurisdiction.
- Support system piping and safety relief valve discharge piping. Boiler's internal piping and wall mount bracket can be damaged if subjected to excessive weight.
- Size central heating pump (and domestic hot water pump, if used) for system requirements only. Internal heat exchanger pump compensates for pressure drop through boiler internal piping and heat exchanger.
- Thoroughly clean and flush system before connecting to boiler.
- If oil is present in system water, use approved detergent to wash system.

- It is necessary to semi-annually check the water quality of central heating systems.
- Flush system to remove any solid objects such as metal chips, fibers, or Teflon tape, etc.
- Use purge valve to flush zoned systems, each zone separately. If purge valves and isolation valves are not installed, install them to properly clean the system.
- When purging installations that include standing iron radiators and systems with manual vents at high points, start with nearest manual air vent. Open the vent until water flows out, then close vent. Repeat this procedure, working toward furthest air vent.
- Install a basket strainer if large amounts of sediment is present. Keep basket clear of sediment build up.
- Install a magnetic dirt separator in the hydronic system where there are cast iron or steel components, or where the previous boiler was a cast iron heat exchanger. The abrasive, extremely fine sediment is difficult to remove and can deposit onto heat exchange surfaces and accumulate in pump cavities causing reduced efficiency and premature wear.
- Flush system until water runs clean and piping is free of sediment.
- Manufacturer recommends a water treatment product be used for sediment removal.

### 5.2 Special Conditions

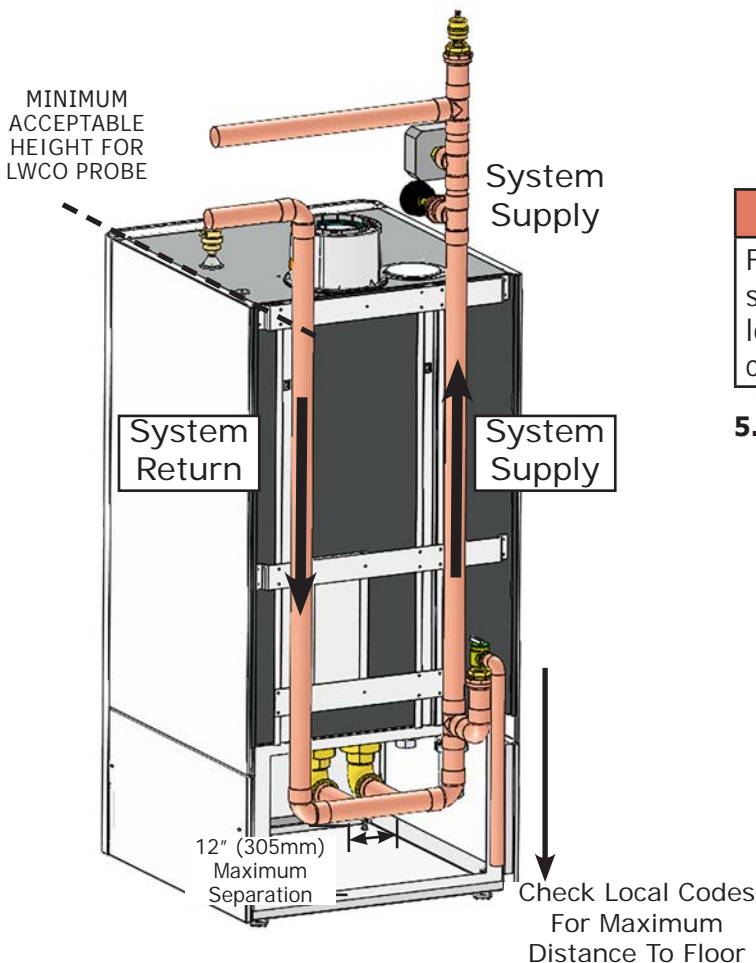
**Note** Do not expose boiler and condensate piping to freezing temperatures.

- System piping exposed to freezing conditions: Use inhibited propylene glycol solutions certified by fluid manufacturer for use with closed water heating system. Do not use automotive or ethylene glycol.
- Boiler installed above radiation level (or as required by authority having jurisdiction). Integral low water pressure switch is provided in boiler.
- Boiler used in connection with refrigeration system. Install piping in parallel with boiler, with appropriate valves to prevent chilled medium from entering boiler.
- System piping connected to heating coils located in air handling unit exposed to refrigerated air circulation. Install flow control valves or other automatic means to prevent gravity circulation of boiler water during cooling cycle.

**FIGURE 5-1 Safety Relief Valve Discharge Piping**



**FIGURE 5-2 System Piping - LWCO Probe Location**  
Viewed from Back of Boiler



**⚠ WARNING**

Burn and scald hazard. Safety relief valve could discharge steam or hot water during operation. Install discharge piping per these instructions.

**5.3 Safety Relief Valve and Air Vent**

- Install safety relief valve using field supplied pipe fittings. See figure 5-1
- Install safety relief valve with spindle in vertical position.
- Do not install shutoff valve between boiler and safety relief valve.
- Install discharge piping from safety relief valve.
- Use ¾" or larger pipe.
- Use pipe suitable for temperatures of 375°F (191°C) or greater.
- Individual boiler discharge piping shall be independent of other discharge piping.
- Size and arrange discharge piping to avoid reducing safety relief valve relieving capacity below minimum relief valve capacity stated on rating plate.
- Run pipe as short and straight as possible to location protecting user from scalding and properly drain piping.
- Install union, if used, close to safety relief valve outlet.
- Install elbow(s), if used, close to safety relief valve outlet and downstream of union (if used).
- Terminate pipe with plain end (not threaded).

**⚠ WARNING**

Fire, explosion hazard. Mount boiler vertically or slightly tilted backward to insure proper function of low water cutoff. Failure to follow these instructions could result in death or serious injury.

**5.4 Low Water Cutoff**

- Boiler is equipped with Low Water Pressure Switch.
- Low Water Cutoff (LWCO) probe location. See figure 5-2 for minimum probe height. Do not install shutoff valve between boiler and LWCO probe..
- If using separate stand pipe, install air vent using tee to avoid nuisance shutdowns.
- Arrange piping to prevent water dripping onto boiler.
- Connect probe signal wires to shutdown terminal (BL) on control board, so it does not interfere with post purge.

### 5.5 Trim Piping

- Temperature - Pressure Gauge. Install temperature pressure gauge using field supplied piping. See figure 5-3. Install as close to boiler supply fitting as practical and visible.
- Boiler has integral drain valve located inside jacket directly underneath pump. Install provided external drain valve.

### 5.6 System Piping

- See Table 4 for basic system piping configurations.
- Systems with appropriately sized automatic fill valves may be required by local authority having jurisdiction to have back flow prevention devices if used.
- Single boiler system. See figures 5-4, 5-5 for general guidance. Additional considerations:
  - Boiler control is designed for single central heating pump. Installer responsible for integration of multiple central heating pumps.
  - Boiler control allows domestic hot water prioritization. Function could be lost if central heating pump not directly connected to control system.
- Multiple boiler system. See figures 5-6, 5-7 for general guidance. Additional considerations:
  - Control system requires equivalent water temperatures entering each boiler to properly sequence and adjust system supply temperature.

### ⚠ WARNING

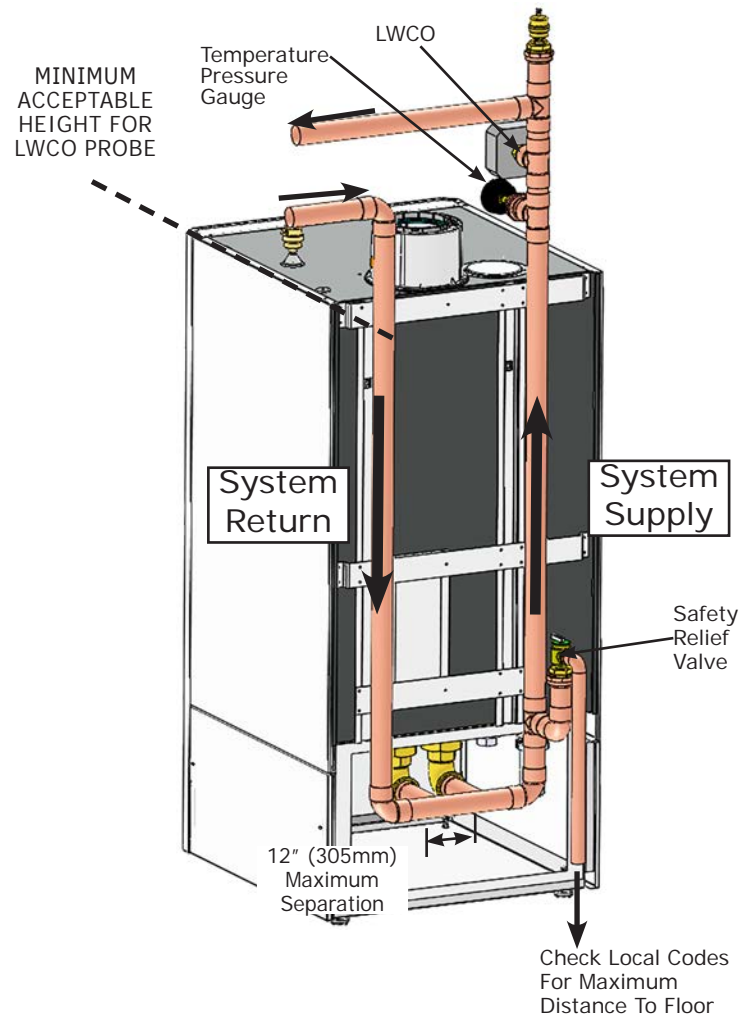
Burn and scald hazard. Verify all plastic caps are removed from boiler connections. Failure to follow these instructions could result in death or serious injury.

- Thoroughly flush all hydronic piping.
- Secure all valves/fittings to boiler.
- Ensure washers supplied are utilized.
- Face valves and fittings to rear wall.
- Fit union connections to supply and return on boiler.
  - A. If soldering to boiler, ensure unions are not connected to the supply and return piping, otherwise internal seals may be damaged.
  - B. Verify appropriately sized isolating valve with filter is fitted to heating return connection.
  - C. Fit pressure relief valve connection vertically before heating isolating valve.
- Connect system valve pipe work to the boiler.

### ⚠ WARNING

Burn and scald hazard. Primary/Secondary piping with closely spaced supply and return lines is mandatory for ASME Code Compliance. Failure to follow these instructions could result in death or serious injury.

**FIGURE 5-3 Temperature Pressure Gauge and Safety Relief Valve Installation - Viewed from Back of Boiler**



**⚠ WARNING**

Burn and scald hazard. Safety relief valve could discharge steam or hot water during operation. Install discharge piping per these instructions.

- Route pressure relief valve discharge piping to the floor. Follow local code with respect to necessary distance to the floor. See Figure 5-3.
- Verify all valves are closed.
- Connect supplied condensate trap to a drain. Verify there is continuous slope towards the drain, avoid level horizontal sections of tubing.

**5.7 Heating System And Refrigeration**

Boiler when used in connection with refrigeration system, must be installed so chilled medium is piped in parallel with the boiler with appropriate valves to prevent chilled medium from entering the boiler.

Boiler piping system of hot water boiler connected to heating coils located in air handling units where they may be exposed to refrigerated air circulation must be equipped with flow control valves or other automatic means to prevent gravity circulation of the boiler water during the cooling cycle.

**5.8 Labor Saver Manifold Installation (supplied) See Figure 5-3**

1. Boiler is supplied with union connection installed on boiler piping for connection to manifold.
2. Configure manifold to suit the application.

**Note** Identify BOILER supply and return when installing manifold.

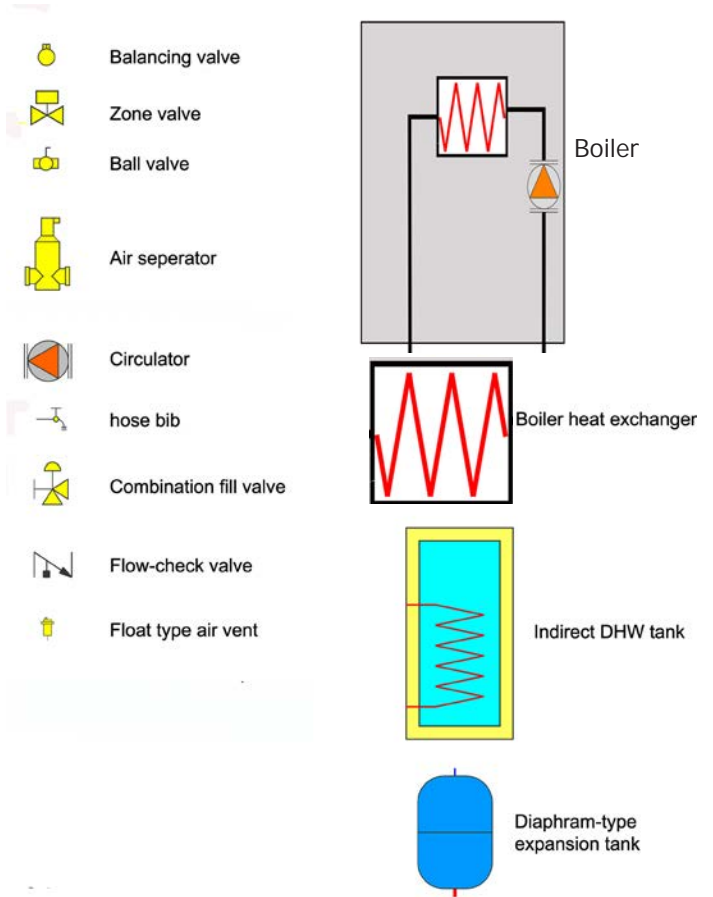
3. Tighten manifold in place. Check for leaks.

## 5 - HYDRONIC PIPING

**Note**

Illustrations are meant to show system piping concept only. Installer responsible for all equipment and detailing required by authority having jurisdiction.

### Piping Legend



**⚠ WARNING**

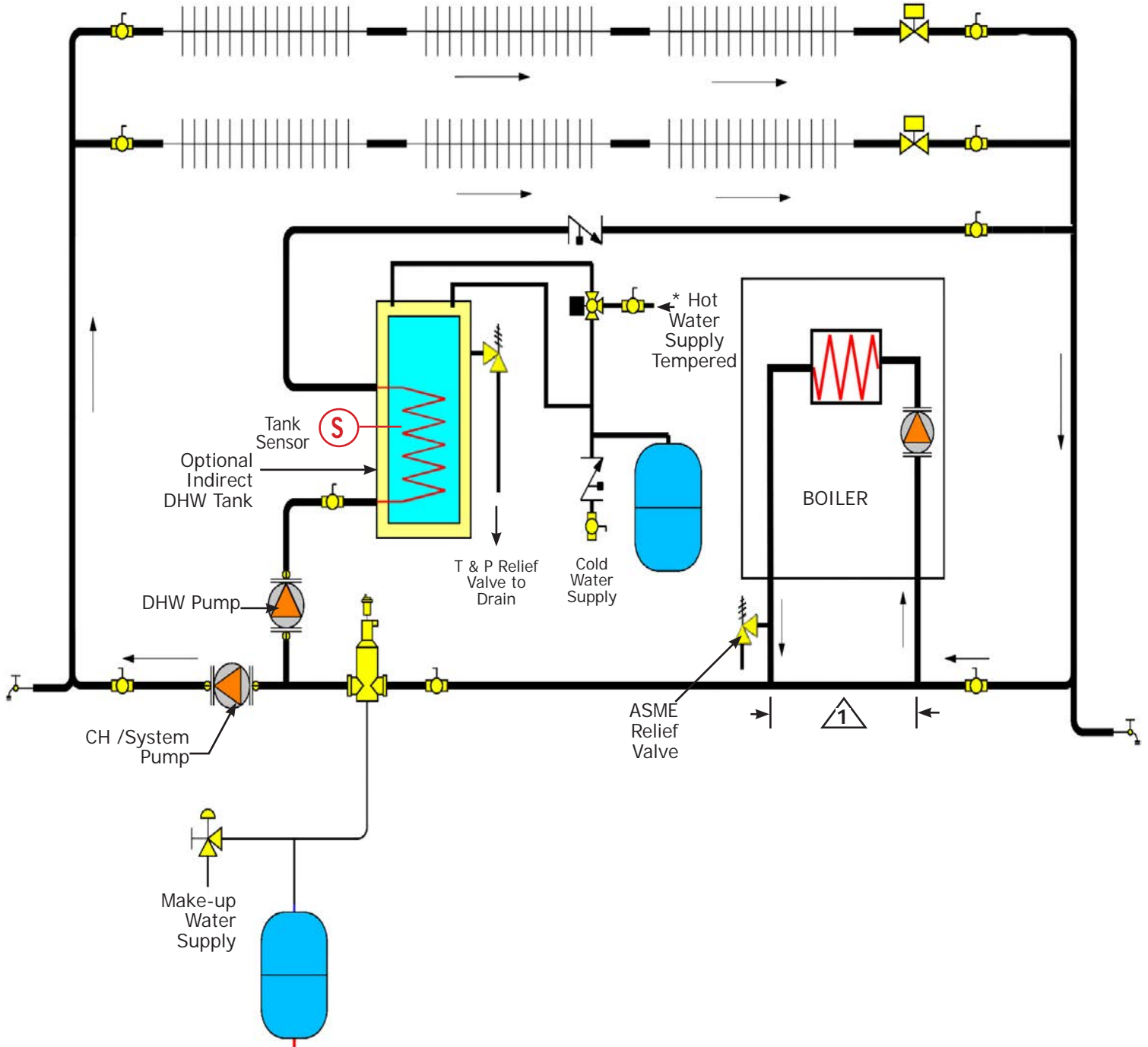
Burn, Scald Hazard! Water temperature over 125°F (51°C) can cause severe burns and scalding. See User's Manual before setting water temperature. Failure to follow these instructions could result in death or serious injury.

**Table 4 - System Piping Configurations**


<b>Single Boiler</b>	Primary/Secondary Pumping	Zone Valves	Figure 5-4
		Zone Pumps	Figure 5-5
<b>Multiple Boilers</b>	See Application Manual 240012832		

## 5 - HYDRONIC PIPING

**FIGURE 5-4 - Primary/Secondary, Zoned, WITH ZONE VALVES, (Optional) Indirect Tank**



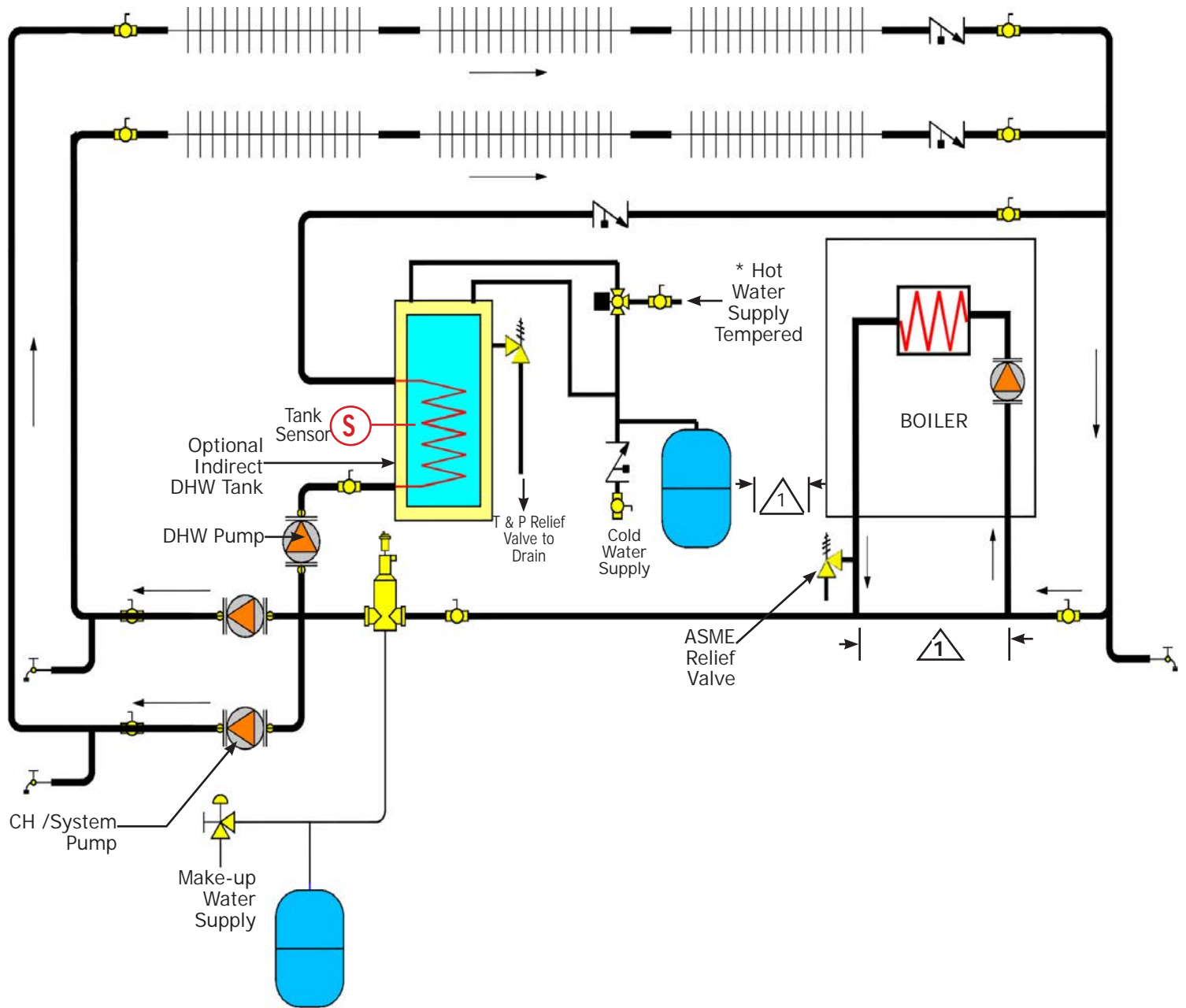
**Note** \* Manufacturer requires all domestic hot water (DHW) installations use an anti-scald valve. Local codes may require additional equipment (expansion tank, relief valves, etc.) Select and size equipment to suit installation and meet code requirements.

**Note**  12" (305mm) Maximum Separation required if Labor Saver is **NOT** used.

**Note** Refer to pump manufacturer literature for proper pump sizing.

## 5 - HYDRONIC PIPING

**FIGURE 5-5 - Primary/Secondary, Zoned, WITH ZONE PUMPS, (Optional) Indirect Tank**



**Note** \* Manufacturer requires all domestic hot water (DHW) installations use an anti-scald valve. Local codes may require additional equipment (expansion tank, relief valves, etc.) Select and size equipment to suit installation and meet code requirements.

**Note** 1 12" (305mm) Maximum Separation required if Labor Saver is **NOT** used.

**Note** Use external pump relay or Argo Zone Control to interface system pump to boiler.

**Note** Refer to pump manufacturer literature for proper pump sizing.



### ! WARNING

Fire, explosion, and asphyxiation hazard. Improper installation could result in death or serious injury. Read these instructions and understand all requirements before beginning installation.

### ! WARNING

ABS/PVC venting shall not be used this product. Use of DWV plumbing pipes to vent this boiler shall be prohibited.

Use of cellular core PVC (ASTM F891), cellular core CPVC, or Radel® (polyphenolsulfone) in venting systems shall be prohibited.

Covering non-metallic vent pipe and fittings with thermal insulation shall be prohibited.

Failure to follow these instructions could result in death or serious injury.

#### Note

*Follow venting manufacturer's equivalent lengths for speciality fittings.*

### 6.1 General

- Installations shall comply with Authority having jurisdiction and in absence of such with:
  - » U.S. ANSI Z223.1 /NFPA 54 in the United States
  - » CSA B149.1 in Canada.
- This boiler requires a dedicated direct vent system or may be category IV Indoor air.
- Vent connections serving appliances vented by natural draft shall not be connected into any portion of mechanical draft systems operating under positive pressure.
- Materials used in the U.S. shall comply with Authority having jurisdiction and in absence of such with: ANSI/ASTM D1785, ANSI/ASTM F441, ANSI/ASTF493, UL1738 or ULC S636.
- Canadian installations only: All venting material, primer and glue must be listed to ULC S636.
- Canadian installations only: First 3 ft. (0.9m) of plastic vent pipe from vent connector must be readily accessible for visual inspection.
- Support piping in accordance with pipe manufacturer's instruction and authority having jurisdiction. In absence of manufacturer's instruction use pipe hooks, pipe straps, brackets, or hangers of adequate and strength located at intervals of 3 ft (1m) or less. Allow for expansion/contraction of pipe.
- Venting system must be free to expand and contract.
- Vent system shall have unrestricted movement through walls, ceilings and roof penetrations.
- Wall and roof openings must be framed to provide support attachment of termination assemblies.

- If vent is penetrating ceilings and /or floors, openings shall have means of fire-stopping in joist areas and proper firestop spacer assemblies installed.
- Standard roof flashing methods shall be employed to install roof flashing.
- Assemble piping in accordance with pipe manufacturer's instructions.
- Unless specifically stated in other sections of this manual, slope exhaust pipe minimum of 1/4" per foot; or vent manufacturer's recommendation whichever is greater, back toward the boiler.
- Support horizontal sections of vent pipe to prevent sags capable of accumulating condensation. Unless otherwise specified support venting every 3 ft. (1m) using steel strapping or equivalent.
- Unless specifically stated in other sections of this manual, use vent pipe manufacturer's specified material for lubrication during assembly of vent pipe.
- Check for proper joint construction when joining pipe to fittings.
- Manufacturer requires use of an approved mechanical fastener, which may vary per vent pipe manufacturer, at every push-fit gasket connection when using a single wall polypropylene vent system.

### 6.2 Removal of Existing Boiler From Common Vent System

When existing boiler is removed from common venting system, common venting system is likely to be too large for proper venting of appliances remaining connected to it.

After removal of existing boiler, following steps shall be followed with each appliance remaining connected to common venting system placed in operation, while other appliances remaining connected to common venting system are not in operation:

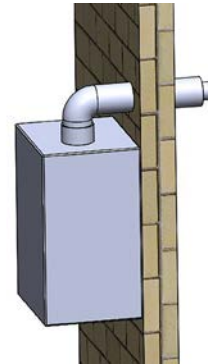
- Seal any unused openings in common venting system.
- Visually inspect venting system for proper size and horizontal pitch. Determine there is no blockage or restrictions, leakage, corrosion and other deficiencies which could cause an unsafe condition.
- When practical, close all building doors, windows, and all doors between space in which appliances remaining connected to common venting system are located and other spaces of building. Turn on clothes dryer and any appliance not connected to common venting system. Turn on exhaust fans, such as range hoods and bathroom exhaust so they will operate at maximum speed. Do not operate summer exhaust fan. Close fireplace dampers.
- Turn on appliance being inspected. Follow lighting instructions. Adjust thermostat so appliances will operate continuously.
- Test for spillage at draft hood relief opening after 5 minutes of main burner operation. Use flame of match or candle, smoke from cigarette, cigar or pipe.

## 6 - COMBUSTION AIR AND VENT PIPING

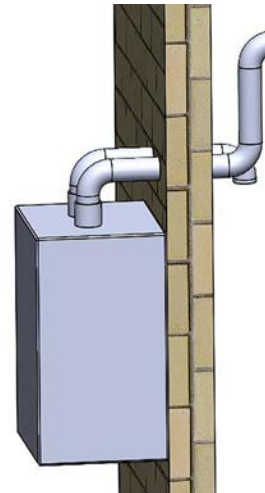
- Determine each appliance remaining connected to common venting system properly vents when tested as outlined above. Then return doors, windows, exhaust fans and any other gas-burning appliance to their previous condition of use.
- Any improper operation of common venting system should be corrected so installation conforms with National Fuel Code, ANSI Z223.1/NFPA 54 and/or Natural Gas and Propane Installation Code, CAN/CSA B149.1. When re-sizing any portion of common venting system, common venting system should be re-sized to approach minimum size as determined using appropriate tables in Chapter 13 of the National Fuel Gas Code, ANSI Z223.1/NFPA 54 and/or Natural Gas and Propane Installation Code, CAN/CSA B149.1.

### 6.3 Definitions

1. **Coaxial piping** – exhaust and air intake pipe have a common axis.



2. **Twin Pipe** – Figure Exhaust and intake air are separate pipes, can be terminated using single wall terminals from the vent manufacturer or field built configuration using elbows or tees.



## 6 - COMBUSTION AIR AND VENT PIPING

### **! WARNING**

Manufacturer recommends this condensing boiler be vented with approved polypropylene venting material. Use only materials listed below for vent pipe, intake air pipe, and fittings. Failure to comply could result in death or serious injury.

### **! WARNING**

ABS/PVC venting shall not be used with this product. Use of DWV plumbing pipes to vent this boiler shall be prohibited.

Use of cellular core PVC (ASTM F891), cellular core CPVC, or Radel® (polyphenolsulfone) in venting systems shall be prohibited.

Covering non-metallic vent pipe and fittings with thermal insulation shall be prohibited.

Failure to follow these instructions could result in death or serious injury.

### 6.4 Approved Venting Materials

Installation shall conform to requirements of authority having jurisdiction or in absence of such requirements:

- USA - National Fuel Gas Code, ANSI Z223.1/NFPA 54

#### Note

Follow venting manufacturer's equivalent lengths for specialty fittings.

#### A. Vent Material Options:

1. 110 /160 mm Polypropylene coaxial (4 inch / 6 inch)  
or
2. 110 mm polypropylene twin pipe (MUST be polypropylene on BOTH intake and exhaust) (4 inch) - conversion kit required.  
or
3. 4 inch CPVC (PVC optional intake only).

#### B. Approved Polypropylene Manufacturers:

Must comply with UL 1738 or ULC S636. The following manufacturers have been evaluated:

- Natalini
- DuraVent®
- Centrotherm
- Z-Flex®

Note: Maximum equivalent length may vary between manufacturers.

#### C. Vent Termination

- Do not include terminations for equivalent length calculations.
- Terminate combustion air and vent pipes with fittings or concentric vent kit.  
Use horizontal pipe for vent and 90° elbow for combustion air termination when using fittings.
- Separate vent terminal from air inlet terminal to prevent flue gas recirculation. If T-Terminal is used on flue pipe at sidewall, air inlet terminal shall be at least 36" or more away from vent terminal.
- Locate combustion air intake termination as far as possible from swimming pool, swimming pool pump house, and other sources of airborne chlorine.
- Locate combustion air and vent terminals as required by authority having jurisdiction.
- Use black ultra violet stabilized polypropylene when exposed to sunlight, wind, or prone to freeze ups.

### **! WARNING**

Asphyxiation hazard. Before securing the screws ensure the pipe has been pushed in a minimum of 1-3/4" (45 mm) into the gasketed end of the other pipe. Failure to follow these instructions could result in death or serious injury.

### 6.5 Coaxial

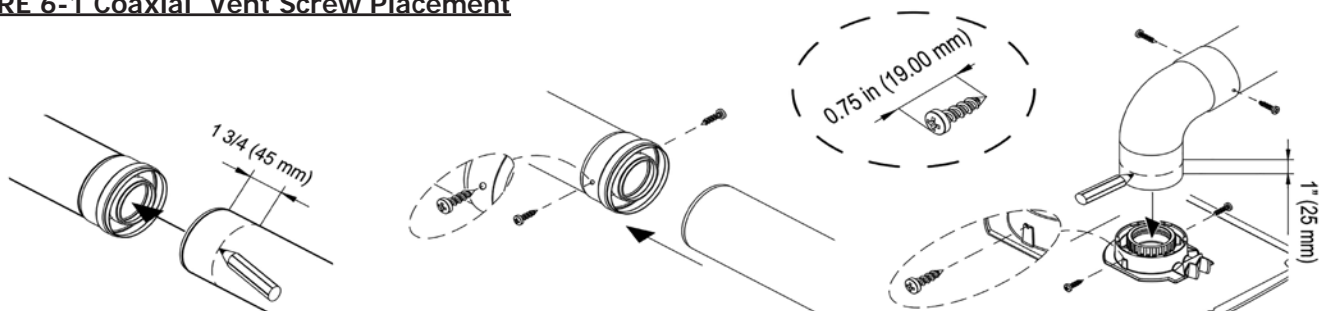
#### A. Coaxial Vent Screw Placement

Fasten two (2) screws through the outer intake pipe behind the gaskets at equal distances approximately 180° apart.

Use zinc coated sheet metal screws in accordance with vent pipe manufacturer's instructions.

1. Before securing the screws, verify pipe is inserted in accordance with pipe manufacturer's instructions.
2. When connecting vent pipes, follow vent pipe manufacturer's instructions regarding lubrication.

**FIGURE 6-1 Coaxial Vent Screw Placement**



**⚠ WARNING**

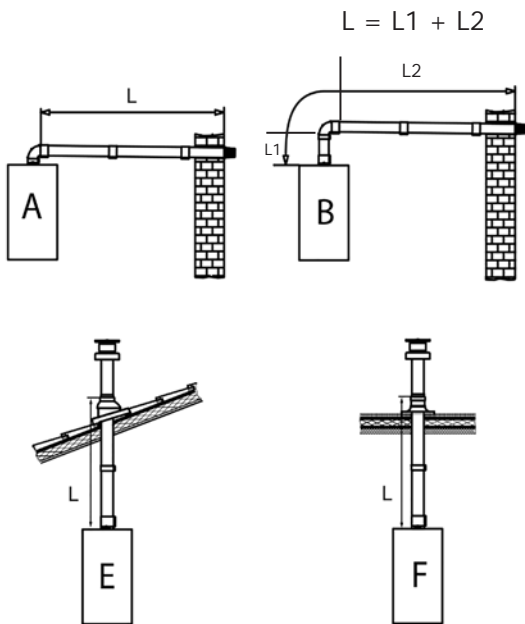
- Covering non-metallic vent pipe and fittings with thermal insulation shall be prohibited.
- Use of cellular core PVC for venting flue gas could result in death, or serious injury.
- Coaxial venting shall be fastened with screws. Twin pipe venting is NOT fastened with screws.

**A. Venting Instructions**

Maximum Length = L	
A B	21' (6.4 m)
E F	21' (6.4 m)

Coaxial Elbows - Equivalent length	
Elbow	Total Length Reduction
45°	1' 8" (0.5 m)
90°	3' 4" (1.0 m)

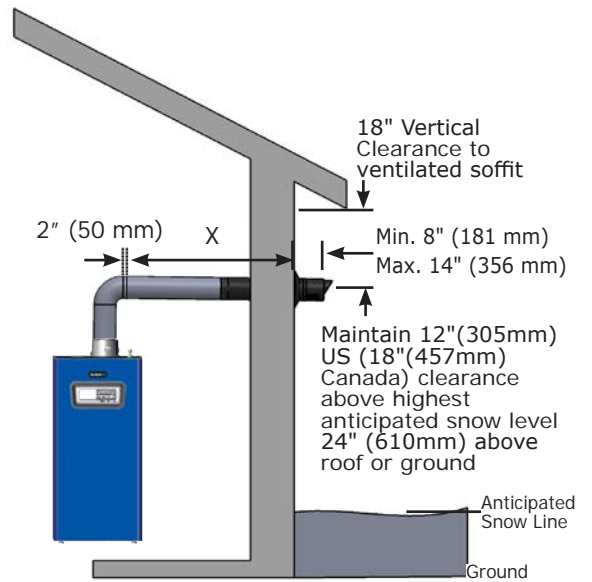
Illustration shows examples of maximum equivalent lengths.



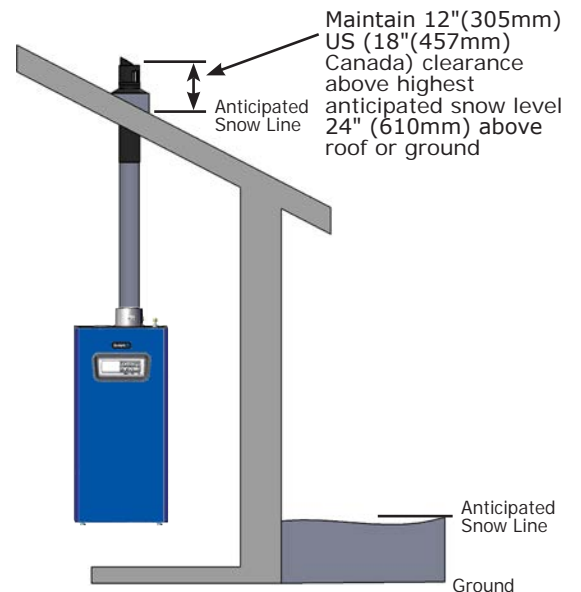
**B. Coaxial Flue Options**

- Standard horizontal termination is suitable only for horizontal applications.
- Maximum permissible equivalent vent length is 21 ft. (6.4 m)
- An "in line" elbows in flue system must be taken into consideration

**FIGURE 6-2 Side Wall Coaxial Venting**



**FIGURE 6-3 Roof Mount Coaxial Venting**



- The first elbow in horizontal run is NOT included in any equivalent length calculations

Elbow	Total Length Reduction
45°	1' 8" (0.5 m)
90°	3' 4" (1.0 m)

**⚠ WARNING**

Asphyxiation hazard! Improper installation could result in death or serious injury. Read Twin Pipe Installation Instructions completely and understand all requirements before beginning installation.

**6.6 Twin Pipe Polypropylene and CPVC Systems**

Twin pipe venting allows exhaust flue and intake flue to be separated from each other. Fresh air is drawn in at a different area from the flue terminal location.

**A. Twin Pipe Polypropylene System**

Single wall polypropylene is used for both exhaust and air intake piping.

To transition from Coaxial at the top of the boiler to Twin Pipe polypropylene venting an adapter kit is available. Figure 6-5.

**B. Twin Pipe Separated Flue** Exhaust and combustion air intake are not located in same general location. Figure 6-6.

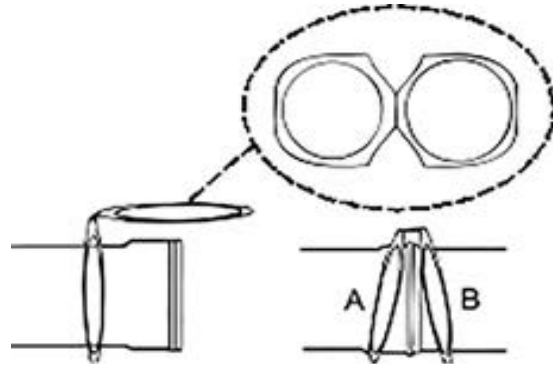
**C. Twin Pipe - Common Atmospheric Zone Termination**

Exhaust and combustion air intake are located in same general location and are of equal length. See Figures 6-7 to 6-9.

**6.7 Twin Pipe Spring Clamp Instructions - See Figure 6-4**

Manufacturer recommends use of a mechanical fastener at every push-fit gasket connection when using a polypropylene vent. Follow vent manufacturer instructions or, if unavailable, below when installing a mechanical fastener:

- Take dual flue mechanical fastener with larger hole in it and place it onto male end of pipe.
- Slide clamp all the way down the pipe with smaller opening of clamp towards female end of the pipe.
- Bend clamp over the female end of pipe "A" and slide male end of pipe "B" through clamp and into female end of pipe "A".

**FIGURE 6-4 - Mechanical Fastener for Twin Pipe****Note**

*Mechanical fastener is necessary for dual flue pipe. Dual flue mechanical fastener is for indoor use only and should not be used in outdoor applications.*

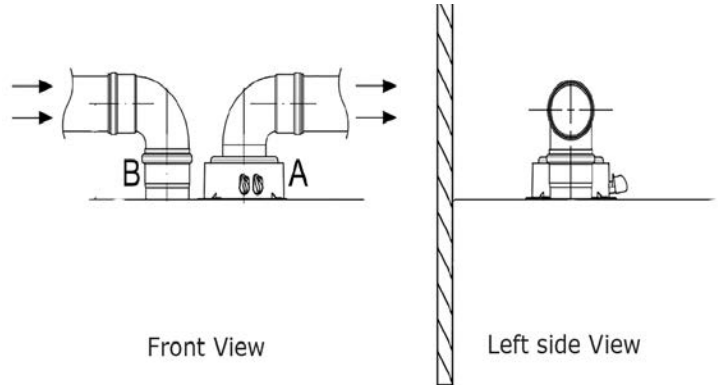
**⚠ WARNING**

Asphyxiation hazard! For DuraVent polypropylene twin pipe only. The twin pipe vent connections on the 380 boiler are designed to accept 110 mm. DuraVent polypropylene 4" venting measures 100 mm.

Manufacturer requires transition pieces from DuraVent to adapt from 110 mm to 100 mm. One transition is required for the exhaust and one is required for the fresh air intake.

Failure to follow these instructions could result in death or serious injury.

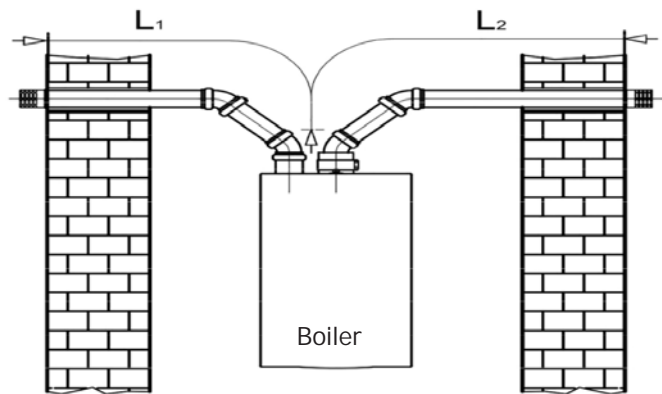
**FIGURE 6-5 - Two Pipe Polypropylene System Adapter**



**⚠ WARNING**

Asphyxiation hazard! Improper installation could result in death or serious injury. Read Twin Pipe Installation Instructions completely and understand all requirements before beginning installation.

**FIGURE 6-6 - Separated Horizontal Flue Termination**



**Twin Pipe Maximum Vent Lengths (See Figure 6-6)**

Intake Vent	L1	49 ft (15 m)
Exhaust Vent	L2	51 ft (15.5 m)
Combined Vent	L1+L2	100 ft (30.5 m)

Elbow	Total Length Reduction
45°	10" (0.3 m)
90°	2 ft (0.6 m)

**Note** Do not count first elbow against maximum vent length.

**Note** If using indoor air for combustion do not exceed 100ft (30m) exhaust vent pipe.

## 6 - COMBUSTION AIR AND VENT PIPING

### 6.8 Venting Configurations

Various venting configurations can be applied to this boiler. For guidance see Venting Configuration Table 6A and corresponding figures.

**Note** *Use of vent covers may cause freezing. If using vent covers overall vent length must be considered. Failure to heed this information may compromise operation of this boiler.*

**Table 6A - Combustion Air - Venting Locations**

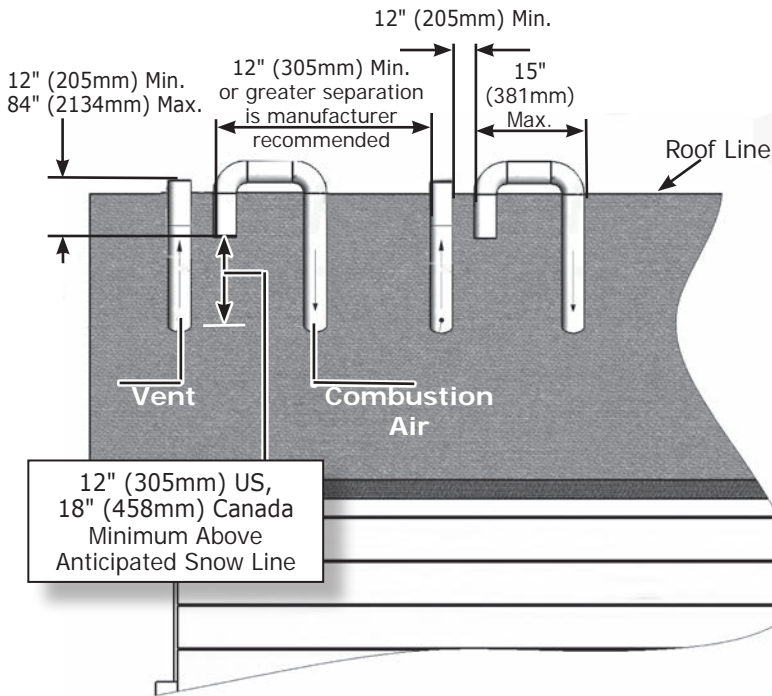
Flue Gas Location	Combustion Air Location	Flue Gas Terminals	Corresponding Figures
<b>Roof</b>	Roof	Two Pipe	Figure 6-8
	Side Wall	Single Pipe	Figure 6-12
	Inside Air	Single Pipe	Figure 6-14
<b>Sidewall</b>	Roof	Single Pipe	Figure 6-13
	Side Wall	Two Pipe	Figures 6-9, 6-10, 6-11
	Inside Air	Single Pipe	Figure 6-15

**Table 6B - Combustion Air - Venting Terminal Type**

Type	Location	Terminal Type	Corresponding Figures
<b>Venting (Flue Gas)</b>	Side Wall	S-Terminal with 90° elbow	Figure 6-9, 6-10
		T-Terminal	Figure 6-13
	Roof	Straight Terminal	Figure 6-12,6-13
<b>Combustion Air (Fresh Air)</b>	Side Wall	Raised 90° down elbow	Figure 6-9
		90° down elbow	Figure 6-10, 6-12
	Roof	Raised 90° down elbow	Figure 6-8, 6-13

## 6 - COMBUSTION AIR AND VENT PIPING

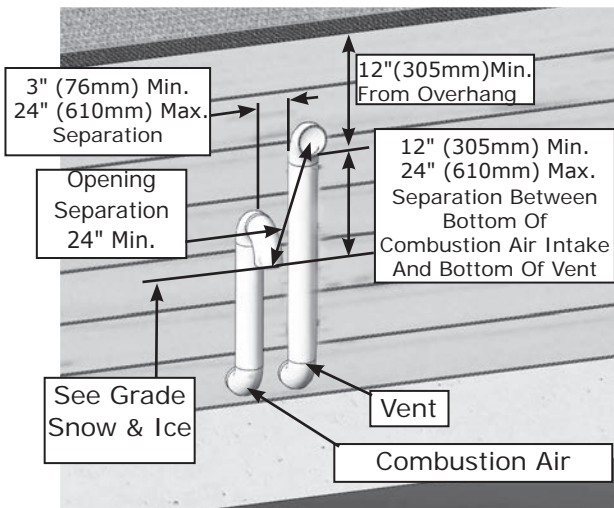
**FIGURE 6-7 Two Pipe Roof Vent**



**Roof Terminations**

- 12" (205mm) Min. horizontal separation between combustion air intake and vent of same appliance.
- 12" (205mm) Min. 84" (2134mm) Max. vertical separation between combustion air intake and vent of different appliances.
- 15" (381mm) Max. horizontal length of vent.
- Min. vent/intake between different appliances 12" (305mm).
- Max. allowable total vertical vent length with outside exposure is 10 ft. (3.05m).
- Abandoned unused masonry chimney may be used as chaseway for combustion air and vent. Both combustion air and vent pipe must exit above top of chimney with clearances as shown in figure 6-7.

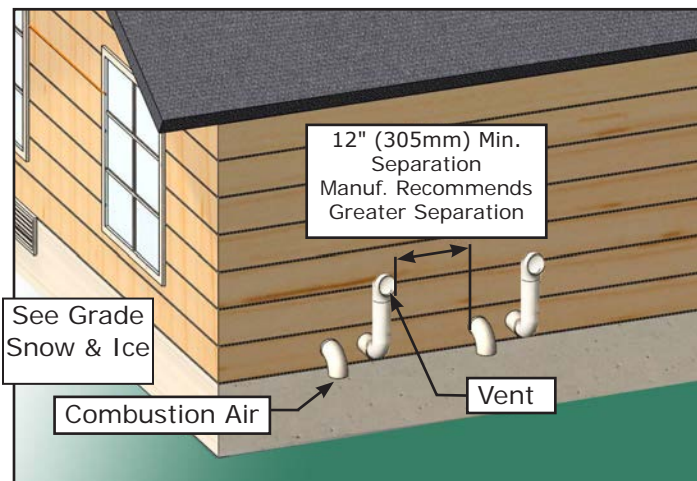
**FIGURE 6-8 Two Pipe Side Wall Vent**



**Side Wall Terminations**

- 3" (76mm) Min. 24" (610mm) Max. Separation horizontal separation between combustion air intake and vent terminations.
- 12" (305mm) Min. vertical separation between combustion air intake and vent terminations.
- 12" (305mm) min. 24" (610mm) Max. separation between bottom of combustion air intake and bottom of vent.
- Multiple terminations as shown in 6-7, and 6-10 must be a min. of 12" (305 mm) horizontally between vent of one termination and air intake of next appliance. Manufacturer recommends greater separation.
- Max. allowable total outside exposure vent length equals 10 ft. (3.05m).
- Maintain a pitch of 1/2" per ft. (42mm/m) outside exposure back to boiler to ensure proper condensate drainage for horizontal runs.

**FIGURE 6-9 Two Pipe Side Wall Vent (Multiple Appliances)**



**Grade, Snow & Ice**

Maintain 12"(305mm) US (18"(457mm) Canada) clearance above highest anticipated snow level 24" (610mm) above roof or ground.  
Avoid locations where snow may drift and block vent and combustion air. Ice or snow may cause boiler to shut down if vent or combustion air becomes obstructed.

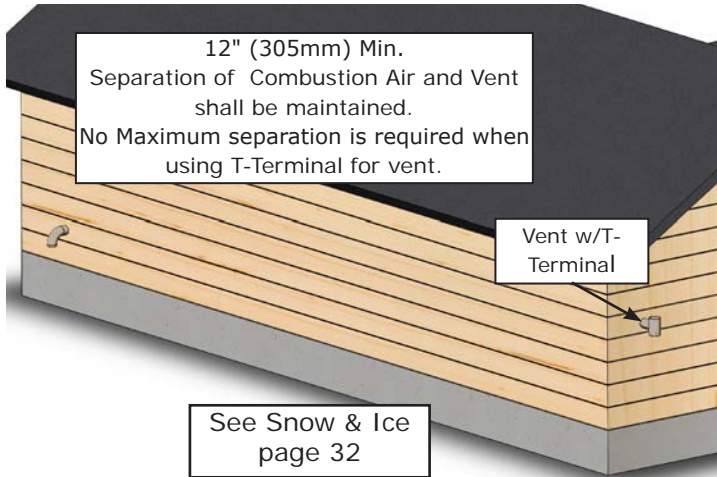
**Doors & Windows**

Combustion air and vent termination must be 12" (305mm) from or below doors, windows or gravity inlet.



## 6 - COMBUSTION AIR AND VENT PIPING

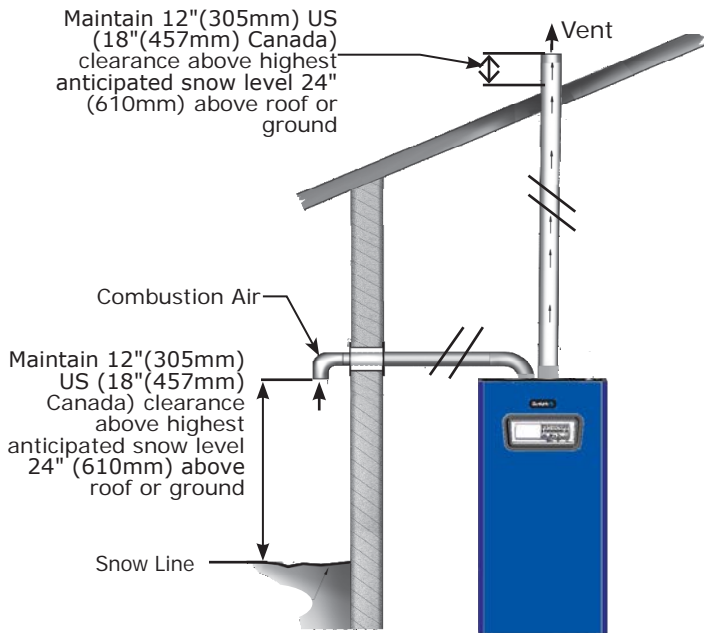
**FIGURE 6-10 Side Wall Venting Terminal w/T-Terminal**



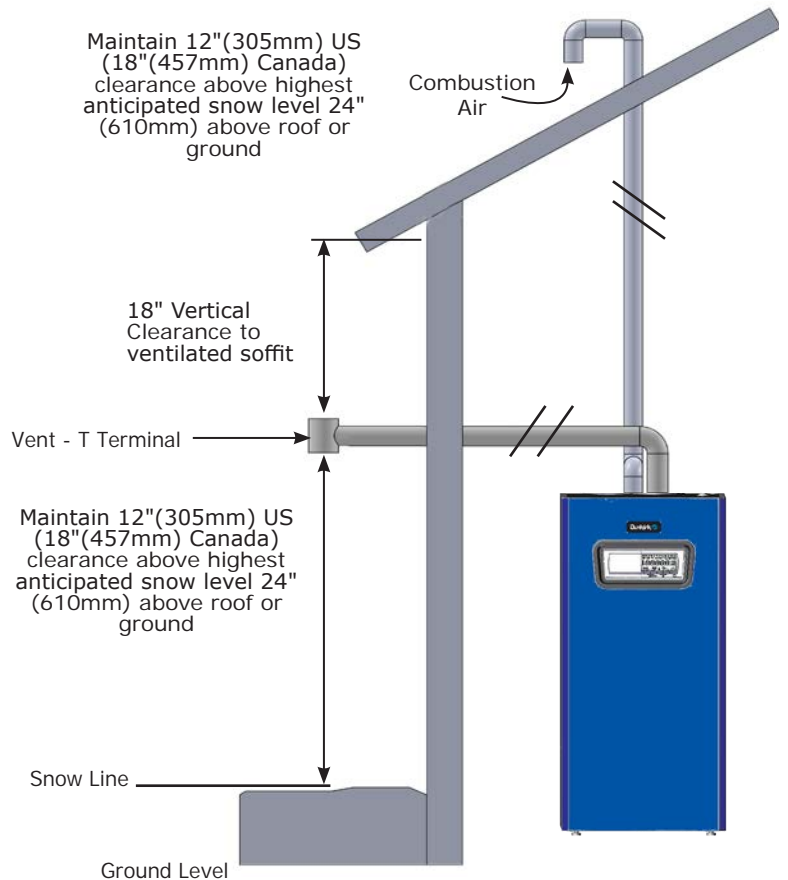
**Note** Configurations of single pipe vent with flue on the sidewall, requires a tee as the vent terminal. See figure 6-10, 6-12 and 6-14

**Note** If separation in Fig. 6-8 is not large enough to prevent cross flow contamination between flue gas and fresh air use T-Terminal as shown in Fig. 6-10. Use of T-Terminal for vent as shown in Fig. 6-10 does not have a max. separation requirement between flue gas and fresh air.

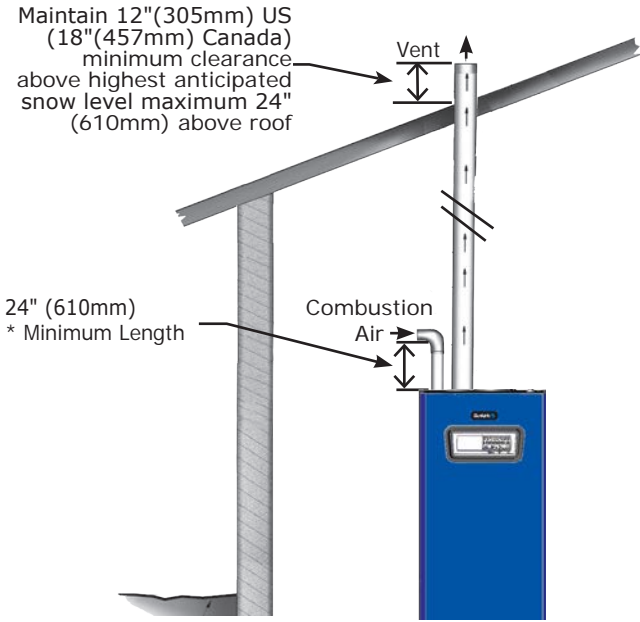
**Fig. 6-11 Flue on Roof, Air Intake on Side Wall**



**Fig. 6-12 Flue on Sidewall, Combustion Air on Roof**

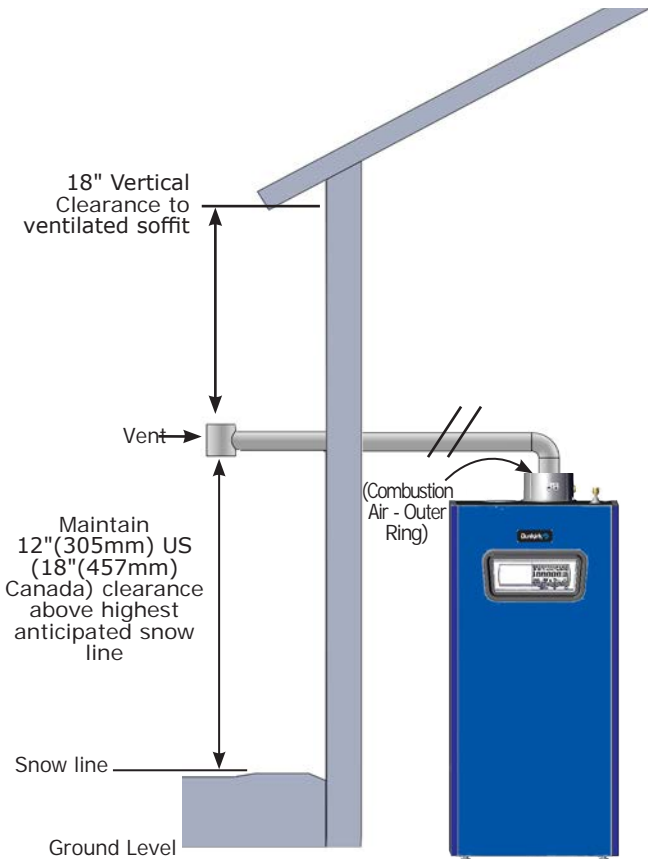


**FIGURE 6-13 Flue on Roof, Indoor Combustion Air**



Combustion air and Vent Piping Length Page 22.

**FIGURE 6-14 Flue on Sidewall, Inside Combustion Air**



**NOTICE**  
Configurations of single pipe vent with flue on sidewall, requires tee as vent terminal. See figures 6-12 and 6-14.

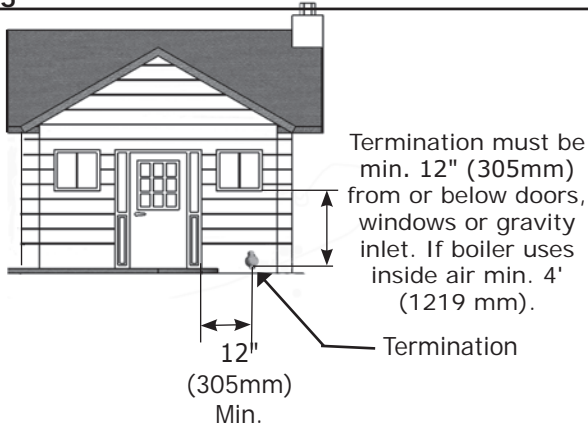
Combustion air and Vent Piping Length Page 22.

6.9 Side Venting Terminal Requirements of :

- USA - National Fuel Gas Code, ANSI Z223.1/NFPA 54.

Venting terminal from doors and windows	See figure 6-15
Venting terminal from forced air inlet of other appliances	See figure 6-16
Venting terminal from snow level	See figure 6-17
Venting terminal from vegetation	See figure 6-18
Venting terminal from public walkway	See figure 6-19

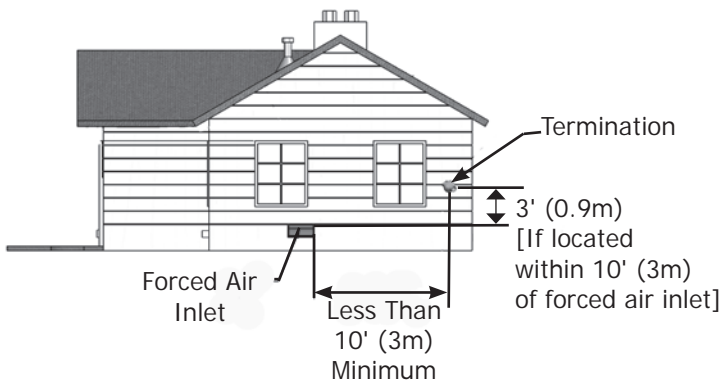
FIGURE 6-15



<b>Doors &amp; Windows</b>	Combustion air and vent termination must be min. 12" (305mm) from or below doors, windows or gravity inlet. If boiler uses inside air min. 4' (1219 mm).
----------------------------	--

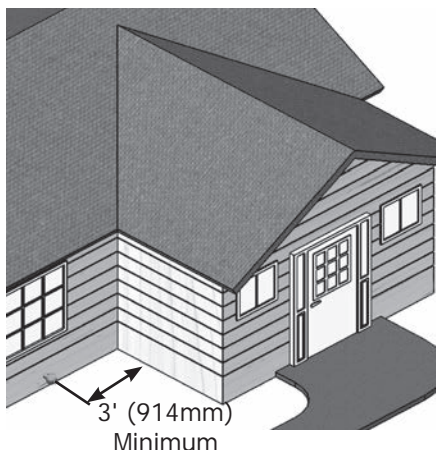
<b>Condensate</b>	Vent gas may condense, forming moisture, may be corrosive. Protect building materials at vent from exhaust of vent gas.
-------------------	---

FIGURE 6-16



<b>Forced Air Inlet</b>	Terminate venting system minimum 3' (914mm) above and 10' (3.0m) from any forced air inlet (except boiler's combustion air inlet).
-------------------------	--

FIGURE 6-17

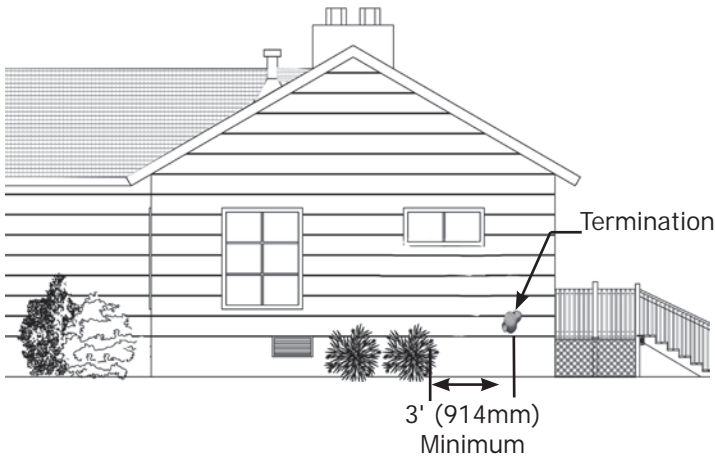


<b>Grade, Snow &amp; Ice</b>	Maintain 12"(305mm) US, 18"(457mm) Canada clearance above highest anticipated snow level, 24" (610mm) above roof.  Avoid locations where snow may drift and block vent and combustion air. Ice or snow may cause boiler to shut down if vent or combustion air becomes obstructed.
------------------------------	--

<b>"L" Corner</b>	Vent termination shall NOT be installed closer than 3' (914mm) from inside corner of "L" shaped structure.
-------------------	--

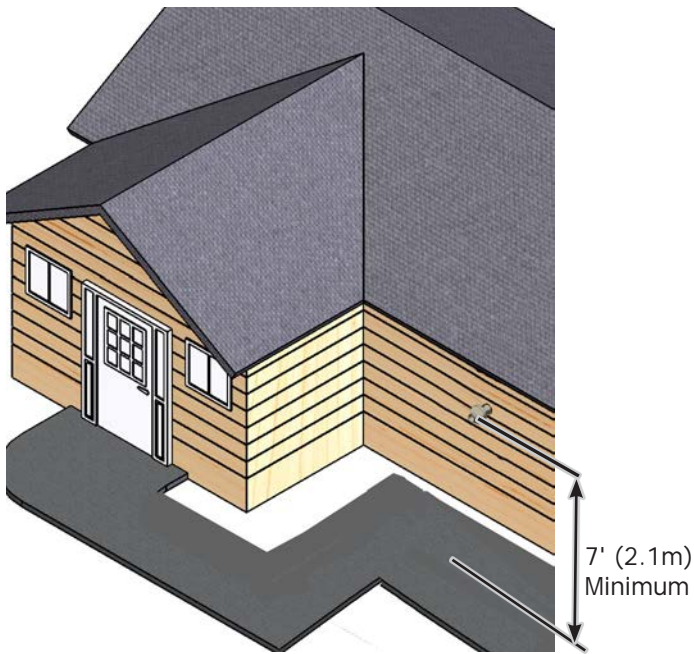
## 6 - COMBUSTION AIR AND VENT PIPING

**FIGURE 6-18**



<b>Vegetation, Plants &amp; Shrubs</b>	Keep vent termination 3' minimum (914mm) away from vegetation. Position termination where vent vapors will not damage plants/shrubs or air conditioning equipment.
<b>Meters, Regulators, deck, porch</b>	Vent termination US only - 4' (1.2m), Canada - 6' (1.9m) horizontally from, no case above or below, electric meters, gas meters, regulators, and relief equipment, or under deck or porch.

**FIGURE 6-19**



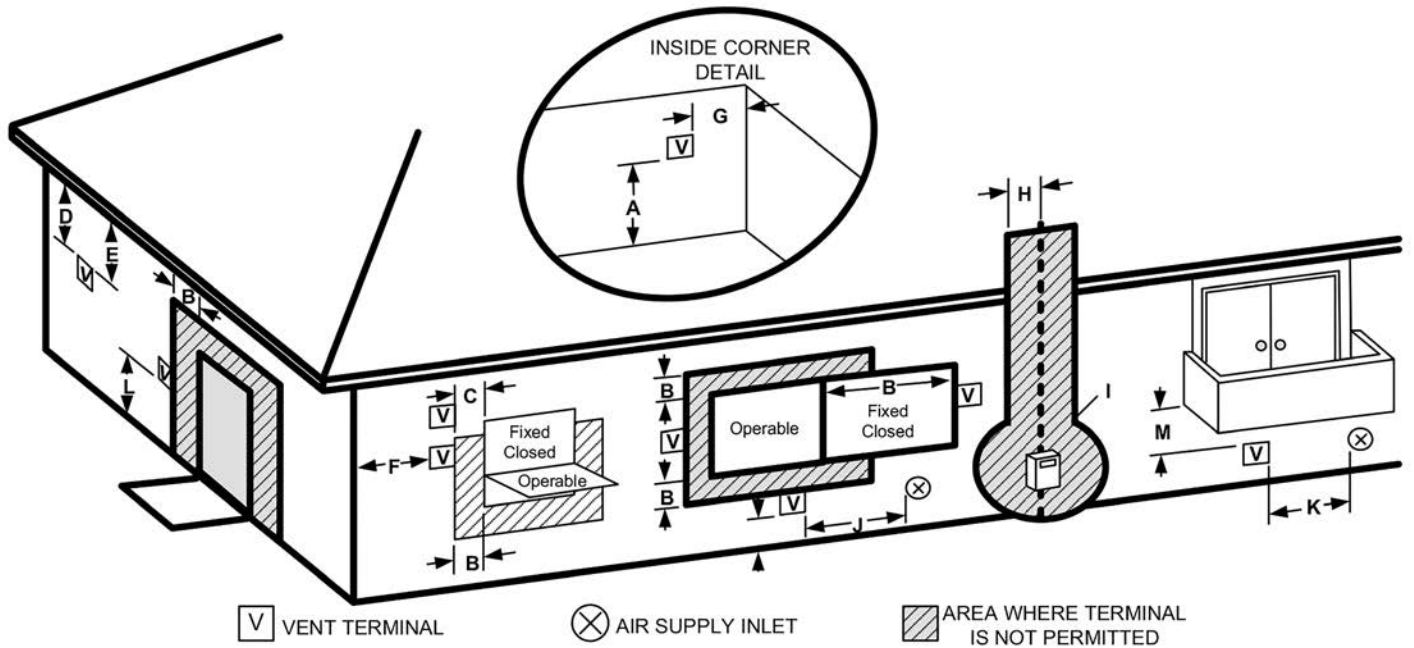
<b>Walkways</b>	Locate vent termination minimum 7' (2.1m) above any public walkway, with consideration to condensate.
<b>People or Pets</b>	Locate combustion air and vent termination to prevent accidental contact with people or pets.
<b>Stones, Balls, Etc.</b>	Position combustion air and vent termination where it will NOT be damaged by foreign objects, such as stones, balls, etc.

<b>Multiple Family Dwellings</b>	Vent shall not terminate directly above paved sidewalk or paved driveway located between two single-family dwellings serving both dwellings.
----------------------------------	--

<b>Vapors</b>	Position termination where vent vapors are not objectionable.
<b>Eddy, Flue Gases</b>	Position termination so it will not be effected by wind eddy, air born leaves, snow, or recirculated vent gases. Give consideration to excessive wind and locate away from windward side of building.

## 6 - COMBUSTION AIR AND VENT PIPING

**FIGURE 6-20 Flue Termination Location**



Vent Termination Minimum Clearances			
		USA	CANADA
A	Clearance above grade, veranda, porch, deck, or balcony	12" (305mm)	12" (305mm)
B	Clearance to window or door that may be opened	12" (305mm)	3 ft. (0.9m)
C	Clearance to permanently closed window	*12" (305mm)	*12" (305mm)
D	Vertical Clearance to ventilated soffit located above the terminal within a horizontal distance of 2 feet (610 mm) from the center line of the terminal	18" (457mm)	18" (457mm)
E	Clearance to unventilated soffit	18" (457mm)	18" (457mm)
F	Clearance to outside corner	9" (229mm)	9" (229mm)
G	Clearance to inside corner	6" (152mm)	6" (152mm)
H	Clearance to each side of center line extended above meter/ regulator assembly	3 ft. (0.9m) within a height of 15 ft. (4.5m) above the meter/ regulator assembly	3 ft. (0.9m) within a height of 15 ft. (4.5m) above the meter/ regulator assembly
I	Clearance to service regulator vent outlet	3 ft. (0.9m)	3 ft. (0.9m)
J	Clearance to non-mechanical air supply inlet to building or the combustion air inlet to any other appliance	12" (305mm)	3 ft (0.9m)
K	Clearance to mechanical air supply inlet	*3 ft. (0.9m)	6 ft. (1.8m)
L	Clearance above paved sidewalk or paved driveway located on public property	*7 ft. (2.1m)	7 ft. (2.1m) <sup>1</sup>
M	Clearance under veranda, porch, deck or balcony	*12" (305mm) <sup>2</sup>	12" (305mm) <sup>2</sup>
*	For clearances not specified in ANSI Z223.1/NFPA 54 or CSA B149.1, clearance will be in accordance with local installation codes and requirements of gas supplier and these installation instructions.		
(1)	Vent shall not terminate directly above sidewalk or paved driveway located between two single family dwellings and serves both dwellings.		
(2)	Permitted only if veranda, porch, deck or balcony is fully open on a minimum of one side beneath the floor.		

**Note** Local Codes or Regulations may require different clearances. Flue termination must be exposed to external air and position must allow free passage of air across it at all times. In certain weather conditions termination may emit a plume of steam. Avoid positioning termination where this may cause nuisance.

**! WARNING**

Asphyxiation hazard. DO NOT use screws to secure piping together. Failure to follow these instructions could cause death or serious injury.

**! WARNING**

Cascade venting of condensing boilers shall be vented with DuraVent® polypropylene venting material. Failure to follow these instructions could result in death or serious injury.

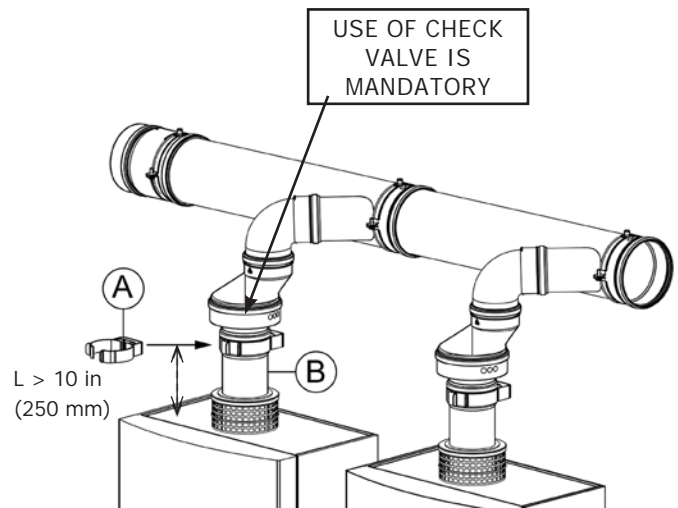
**6.10 Multiple Boiler Venting - General**

- For common exhaust system DuraVent® is the only approved vent manufacturer - DuraVent®. Use of check valve is mandatory.
- See Figures 6-26, 6-27 and 6-28. Termination **must** be vertical through the roof. Sidewall horizontal terminal not allowed.
- On multiple venting applications ensure minimum downward slope of 2 in (50.00 mm) for every 3 ft 4 in (1.00 m) of duct length toward boiler.
- Manufacturer recommends use of CO monitor, calibrate regularly per CO monitor manufacturer instructions.
- Place pipes at least 1 in (30 mm) from heat sources.
- Keep area clean and free of debris.
- On multiple venting applications use only water (H<sub>2</sub>O) as lubricant when inserting pipes together. Do NOT use any type of grease or similar substances.
- Do NOT use screws to secure pipes together.
- Before securing pipe with clamps, verify pipe is inserted per vent manufacturer instructions.
- Install steel strapping (A) of pipe (B) distance of 10 in (250.0 mm) from boiler.
- Secure flue pipe to wall with supports 3 ft. (1 meter) from each other. Secure supports along the joint of each pipe.

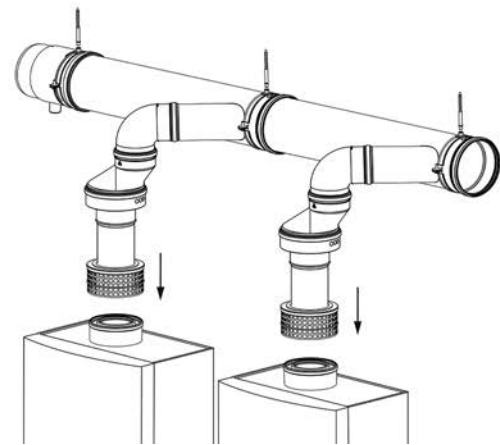
**6.11 Multiple Boiler Venting - Mounting Procedure - See Figures 6-21 thru 6-23**

1. Vent pipes correctly mounted. See Figure 6-22.
2. Line horizontal common vent pipes with male end towards condensate collector end cap.
3. Follow vent manufacturer's instructions when assembling vent pipe to allow for expansion and contraction of vent pipe during use.
4. Hang horizontal common vent pipe, do not fully tighten clamps down.

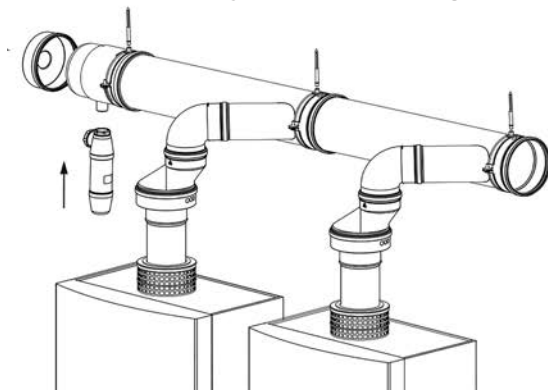
**FIGURE 6-21 Correctly Mounted Piping**



**FIGURE 6-22 Correctly Mounted Piping**

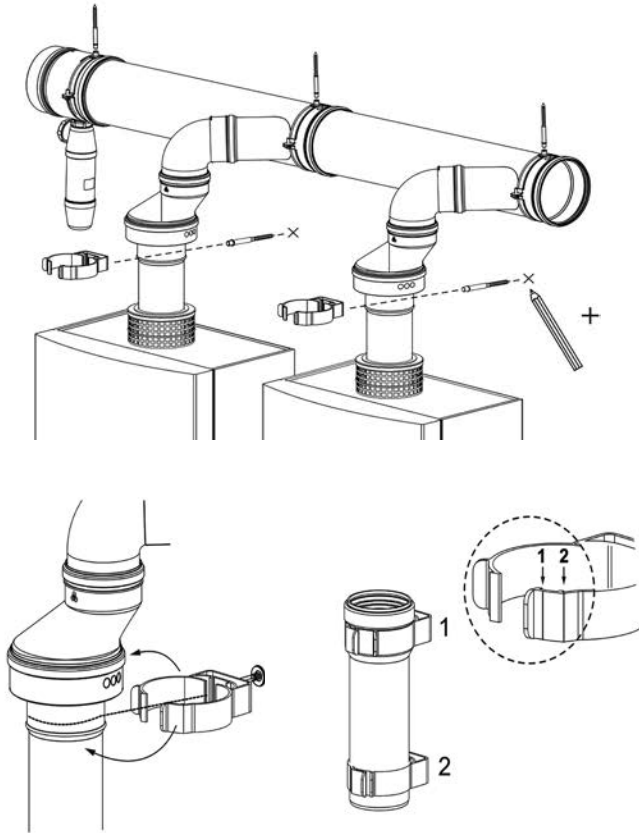


**FIGURE 6-23 Correctly Mounted Piping**



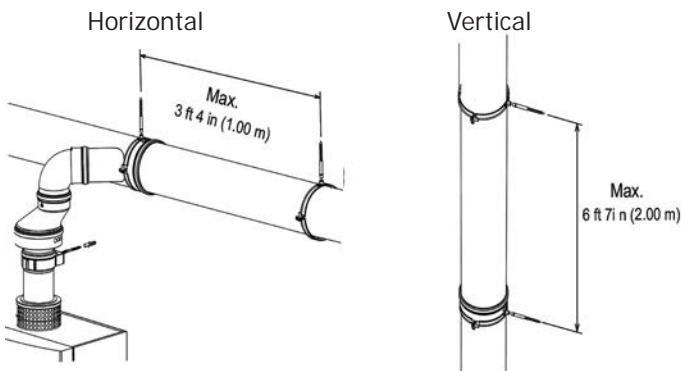
## 6 - COMBUSTION AIR AND VENT PIPING

**FIGURE 6-24 Secure Clamp around Flue Adapter**



5. Connect 90° elbows to horizontal common vent pipe for each boiler in cascade system
6. Connect flue damper to 90° elbow for each boiler in cascade system.
7. Connect boiler flue adapter to flue damper for each boiler in on multiple venting applications. Ensure flue adapters allow for 3° or 2 in. per 3 ft. slope of horizontal collectors back towards condensate collector.
8. Connect intake air screen to flue adapter for each boiler in cascade system. Combustion air shall come from indoors only.
9. Connect cascade vent system to flue connection on top of boilers.
10. Connect end cap and condensate trap to horizontal common vent pipe.
11. Secure flue adapters using approved clamps to wall. Ensure clamps are connected minimum of 10 in. from top of boiler. See Figure 6-24.
12. Secure approved clamp around flue adapter. Ensure clamp is locked in to proper position. See Figure 6-24.
  - A. Position 1 - Clamping around bell end of adapter.
  - B. Position 2 - Clamping around flue pipe adapter.
13. Maximum distance between supports for horizontal pipes 3 ft 4 in. Maximum distance between supports for vertical pipes 6 ft 7 in. See Figure 6-25.
14. Fully tighten horizontal common vent pipe supports.

**FIGURE 6-25 Maximum Distance Between Supports**



## 6 - COMBUSTION AIR AND VENT PIPING

### 6.12 Multiple Boiler Venting - Venting Layout

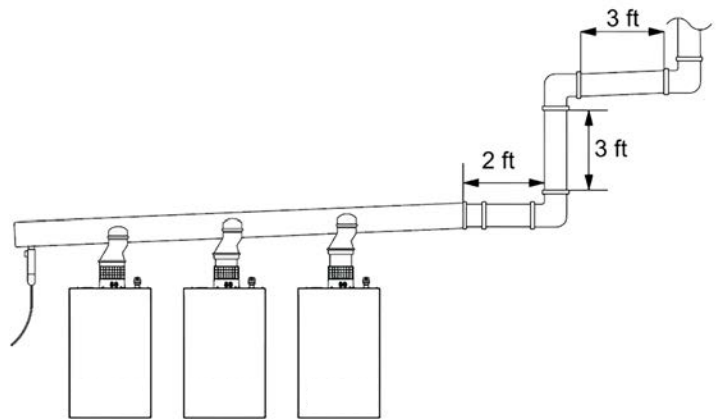
Available pressure at flue outlet is 0.40" w.c. (100pa)

Heat Input (BTUH)	Heat Capacity (BTUH)	Number of Appliances	Maximum Vertical Length					
			6 in (150 mm)		*6 in / 8 in (150 / 200 mm)		8 in (200 mm)	
379,000	348,000	1						
758,000	696,000	2	98.4 ft	30m	98.4 ft	30m	98.4 ft	30m
1,516,000	1,392,000	4	98.4 ft	30m	98.4 ft	30m	98.4 ft	30m
2,274,000	2,088,000	6	-	-	98.4 ft	30m	98.4 ft	30m

#### \*6 in. / 8 in. Vent System:

- Horizontal vent pipe size 6 in. (150 mm)
- Vertical vent pipe size 8 in. (200.00 mm).
- Length between vertical vent pipe and last horizontal vent collector pipe = 3 ft 4 in (1.00 m).
- For calculating other lengths between last collector and shaft, length of vertical height must be reduced by this additional length and by the numbers of bends according to the table.

**FIGURE 6-26**



Elbow Type	6 in.		8 in.	
	Equivalent Length		Equivalent Length	
45°	5 ft 7 in	1.7m	12 ft	3.8 m
90°	13 ft 1 in	4.0m	19 ft	5.8 m

#### 6 in. Multiple Boiler Vent Application Example

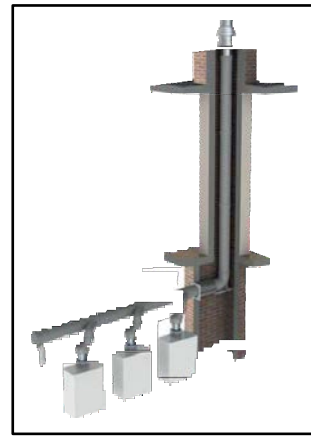
Elbow Equivalent Length	45°	90°
Number of Elbows	-	3
Equivalent Length	-	13 ft 1 in (4.0m)
Total Equivalent Length	39 ft 4-21/64 in (12.0m)	

Total Equivalent Length	39 ft 4 - 21/64 in (12.0m)
Horizontal Length	5 ft (1.5m)
Total Equivalent Horizontal Length	44 ft. (13.4m)
Maximum Vertical Length	98 ft. (29.9m)
Total Vertical Length	54 ft. (16.5m)

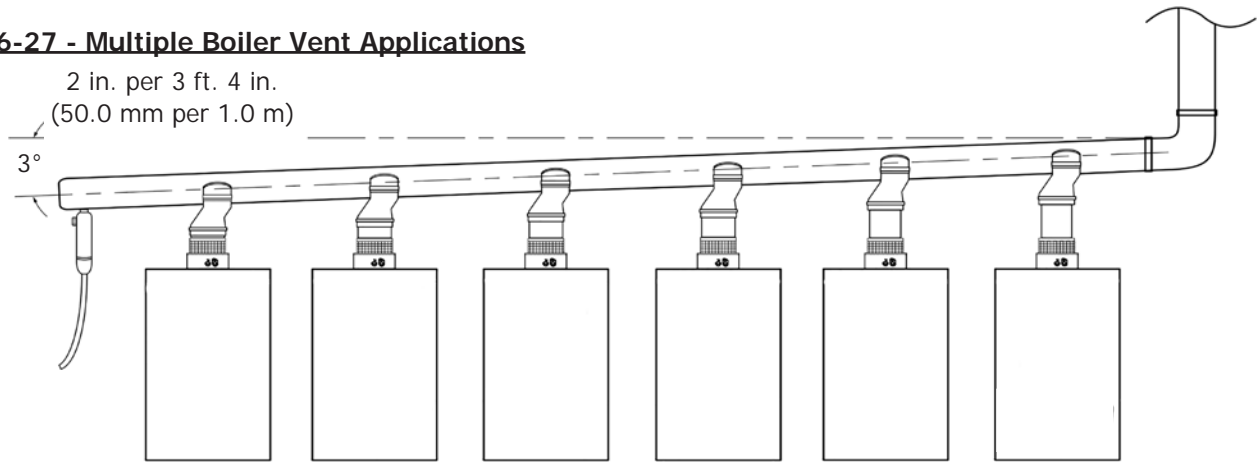


**A. Single Line System**

System consisting of boilers arranged in line each connected to common exhaust manifold.



**FIGURE 6-27 - Multiple Boiler Vent Applications**

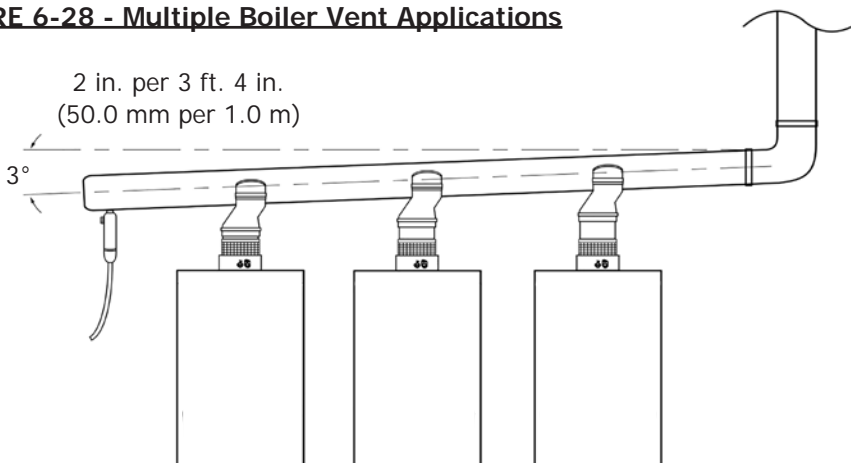


**B. Back to Back System**

This system consists of boilers installed back to back connected to a common exhaust manifold.

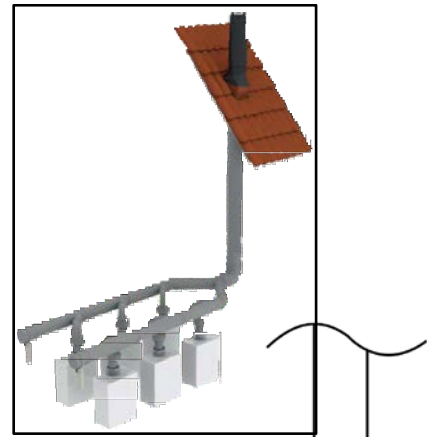


**FIGURE 6-28 - Multiple Boiler Vent Applications**

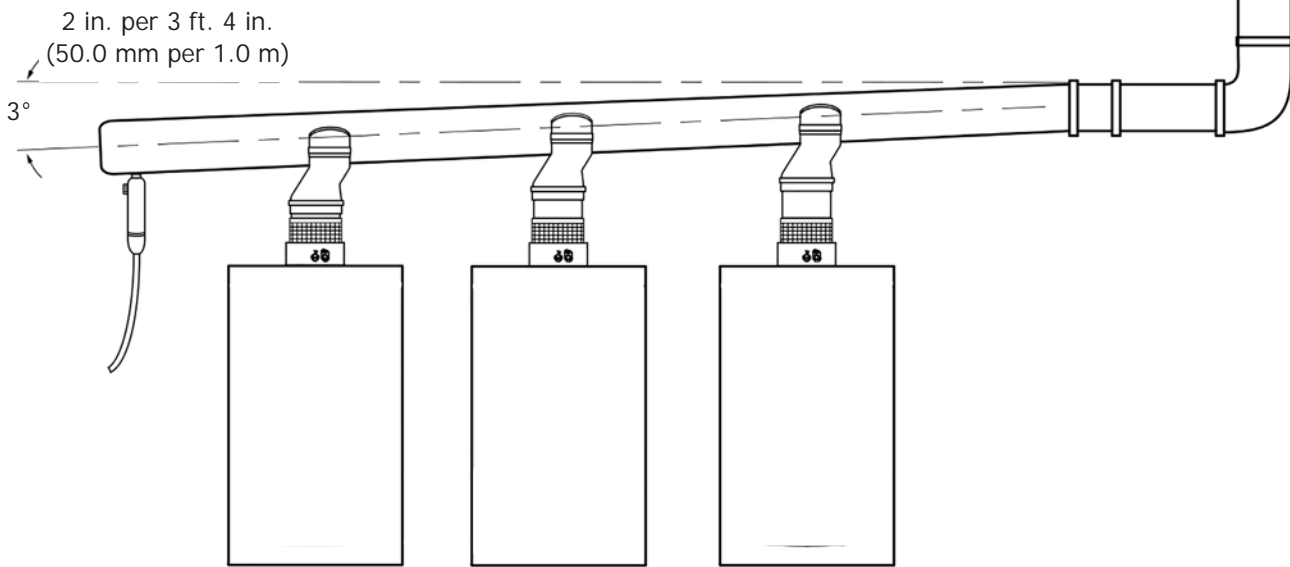


**C. Double Line System**

This system consists of boilers installed on two lines, connected to a common exhaust manifold.



**FIGURE 6-29 - Multiple Boiler Vent Applications**



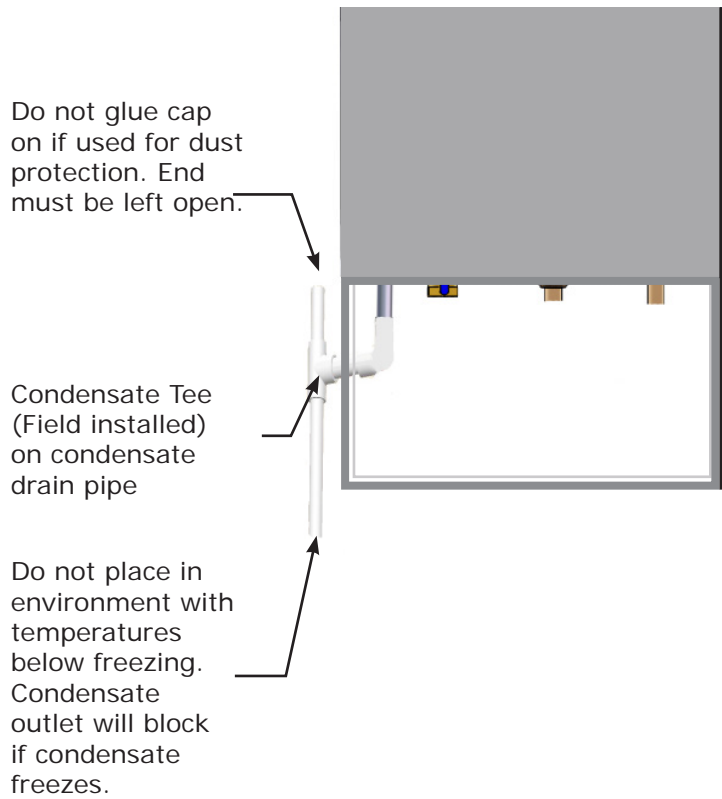
**6.13 Multiple Boiler Venting - Parameter Settings**

To set parameter **P19** see section 9 to ensure check valve in vent opens.

PARAMETER P19 Revs/min (rpm) at minimum Power	
Natural Gas (A)	LPG (E)
30	30

Flue header size shall be calculated by qualified service agency during system design as required by local authority having jurisdiction.

**FIGURE 6-30 Condensate Drain**

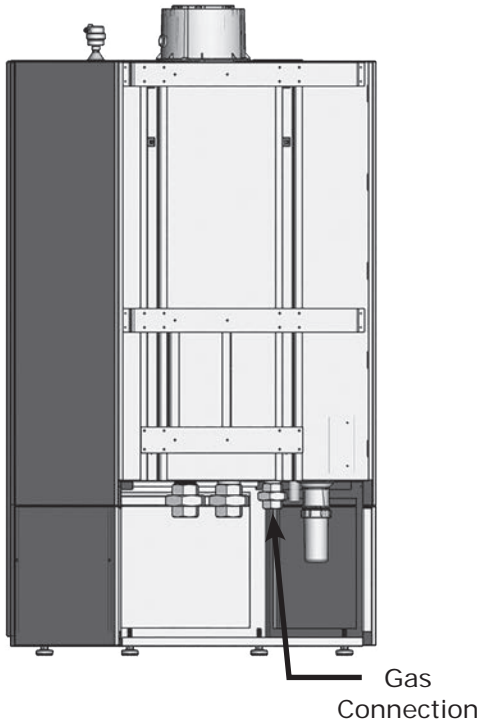


### 6.14 Condensate Piping

- Use materials acceptable to authority having jurisdiction. In absence of such authority:
  - USA - PVC or CPVC per ASTM D1785/D2845 Cement or primer per ASME D2564 or F493.
  - Canada - CSA or ULC certified PVC/CPVC pipe, fittings and cement.
- Slope condensate drain pipe minimum 1/4" per foot (21mm/m) away from boiler.
- Use field source condensate pump if boiler located below disposal point.
- Field source condensate neutralizing kit as required by authority having jurisdiction or for environmentally friendly condensate disposal.

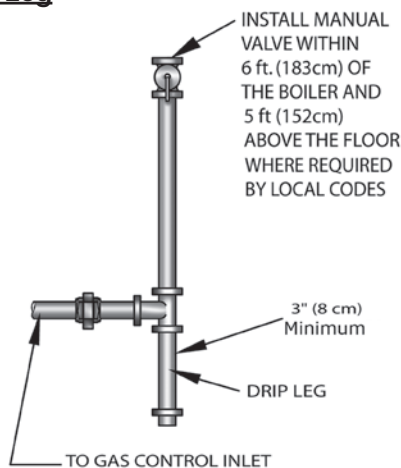
## 7 - GAS SUPPLY PIPING

**FIGURE 7-1 Gas Connection** (View from Back of Boiler)



**Note** Use two (2) wrenches when tightening and fitting to pipe boiler's threaded fittings. Boiler's internal piping can be damaged if subjected to excessive torque.

### 7-2- Drip Leg



Gas Supply		Pressure	
Natural Gas		LP	
Min	Max	Min	Max
3.0" w.c. (0.87 kPa)	10.5" w.c. (2.61 kPa)	8.0" w.c. (1.99kPa)	13.0" w.c. (3.23kPa)

## ⚠ CAUTION

### WHAT TO DO IF YOU SMELL GAS

- Do not try to light any appliance.
- Do not touch any electrical switch; do not use any phone in your building.
- Immediately call your gas supplier from a neighbor's phone. Follow gas supplier's instructions.
- If you cannot reach your gas supplier, call the fire department.

### 7.1 General

- Use piping materials and joining methods acceptable to authority having jurisdiction. In absence of such requirements:
  - USA - National Fuel Gas Code, ANSI Z223.1/NFPA 54
- Size and install gas piping system to provide sufficient gas supply to meet maximum input at not less than minimum supply pressure. DMG-380 requires a gas rate of 377 ft<sup>3</sup>/h (10.7 m<sup>3</sup>/h) for Natural Gas (Gas A) and 149 ft<sup>3</sup>/h (4.2m<sup>3</sup>/h) for Liquid Propane Gas (Gas E).
- Gas meter and supply pipes must be capable of delivering the listed quantity of gas in addition to demand from any other appliances in the house. DMG-380 requires a 1" (25.4 mm) gas supply pipe.
- Support piping with hooks straps, bands, brackets, hangers, or building structure components to prevent or

## NOTICE

Use of CSA approved corrugated, semi-rigid stainless steel tubing with polyethylene jacketing is approved for use with boilers following tubing manufacturer's instructions.

Use of flexible gas tubing also know as "*appliance whip*" is not allowed per NFPA 54.

- dampen excessive vibrations and prevent strain on gas connection. Boiler will not support piping weight.
- Use thread (joint) compound (pipe dope) suitable for liquefied petroleum gas.
- Install external field sourced manual main gas shutoff valve, ground joint union, and sediment trap upstream of gas valve. See figure 7-2.
- Leak test boiler and gas line connections before placing boiler into operation.

### 7.2 LP Conversion

- See conversion instructions included with LP Conversion Kit. Purchased Separately.

**⚠ DANGER**

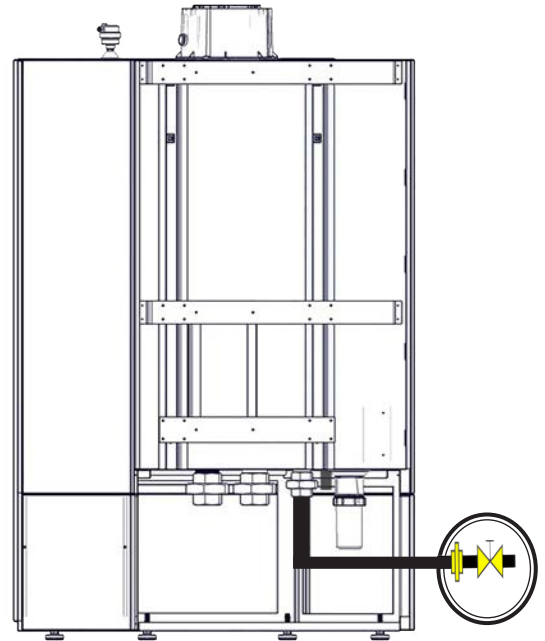
Fire Hazard. Do not use matches, candles, open flames, or other methods providing ignition source. Failure to comply will result in death or serious injury.

**7.3 Leak Check Gas Piping**

Pressure test boiler and gas connection before placing boiler in operation.

- Pressure test over 1/2 psig (3.5 kPa). Disconnect boiler and its individual gas shutoff valve from gas supply system.
- Pressure test at 1/2 psig (3.5 kPa) or less. Isolate boiler from gas supply system by closing manual gas shutoff valve. See figure 7-3.
- Locate leakage using gas detector, noncorrosive detection fluid, or other leak detection method acceptable to authority having jurisdiction. Do not use matches, candles, open flames, or other methods that can provide ignition source.
- Correct leaks immediately and retest.

**FIGURE 7-3 Manual Main Gas Shutoff Valve Outside Boiler Jacket** - (Viewed from Back of Boiler)



**Manual Main Gas Shutoff Valve**

### 8.1 General

Electrically bond boiler to ground in accordance with requirements of authority having jurisdiction. Refer to:

- USA- National Electrical Code, ANSI/NFPA 70.

### 8.2 Electric Knockouts (Figure 8-1)

- **Eight knockouts located on bottom of chassis.**
  - A. Thermostat (Section 8-10)
  - B. Outdoor Reset (Section 8-9)
  - C. Frost Protections (Section 8-12)
  - D. DHW Sensor (Sections 8-11, 8-13)
  - E. Release Input (Section 8-7)
  - F. Shutdown Input (Section 8-15)
  - G. Analog Input (Section 8-8, IF-01 board)
  - H. Analog Output (Section 8-8, IF-01 board)
  - I. Alarm (IF02 or SCU-SO2 board)
  - J. External Heat System Pump (Section 8-8, SCU-SO2 board)
  - K. DHW Diverter/Pump (Section 8-8)
  - L. External Gas Shutoff (Section 8-8)
  - M. Minimum Gas Pressure Switch (Section 8-8)
  - N. Solar Input (Section 8-8)

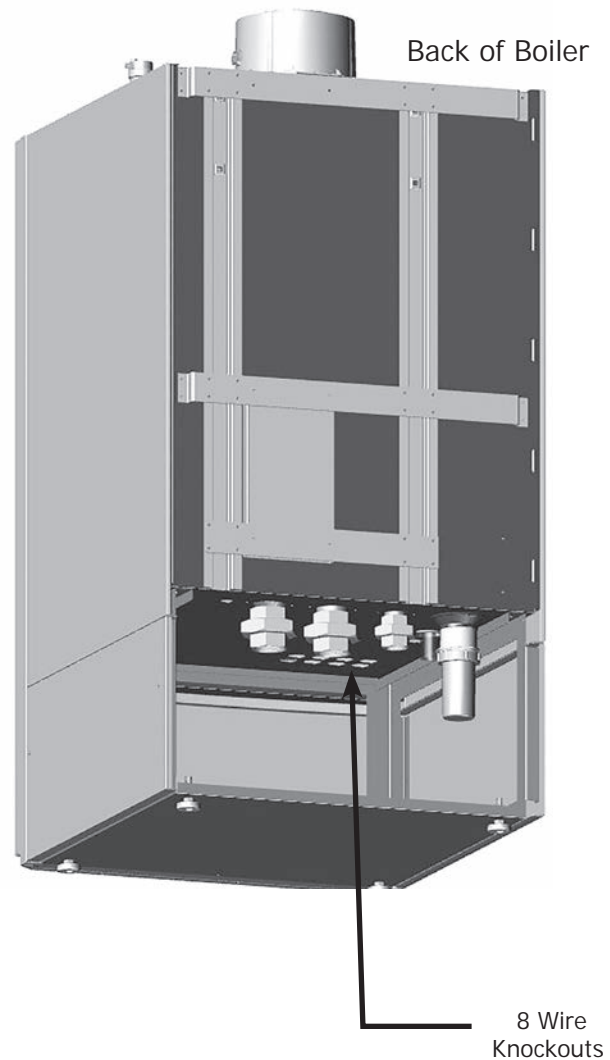
### 8.3 Electrical Connections

- Boiler requires 120V 60Hz power supply. Verify electrical supply is polarized.
- Boiler shall be grounded and on dedicated circuit.
- Shall be one common isolator, providing electrical isolation for boiler and any external controls. Using PVC insulated cable 18 AWGx3C 221°F / 105 °C.
- All wiring must be installed in accordance with requirements of the National Electrical Code and any additional national, state, or local code requirements having jurisdiction. All wiring must be N.E.C. Class 1.
- Canada, installation must conform to CSA C22.1 Canadian Electrical Code Part 1 and any local codes.
- If replacing original boiler wiring use only TEW 105°C or equivalent.
- 12 Amp Maximum rating.

## ⚠ WARNING

Electrical shock hazard. Turn OFF electrical power supply at service panel before making electrical connections. Failure to do so could result in death or serious injury.

**FIGURE 8-1 Electric Knockouts Bottom Of Boiler**



## 8 - ELECTRICAL CONNECTIONS

### 8.4 Access To Connection Block

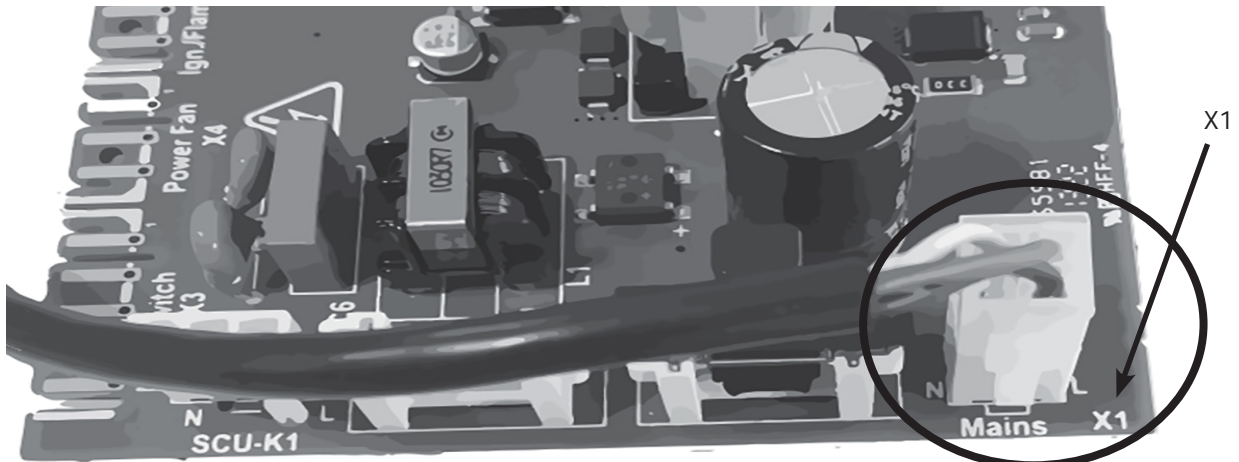
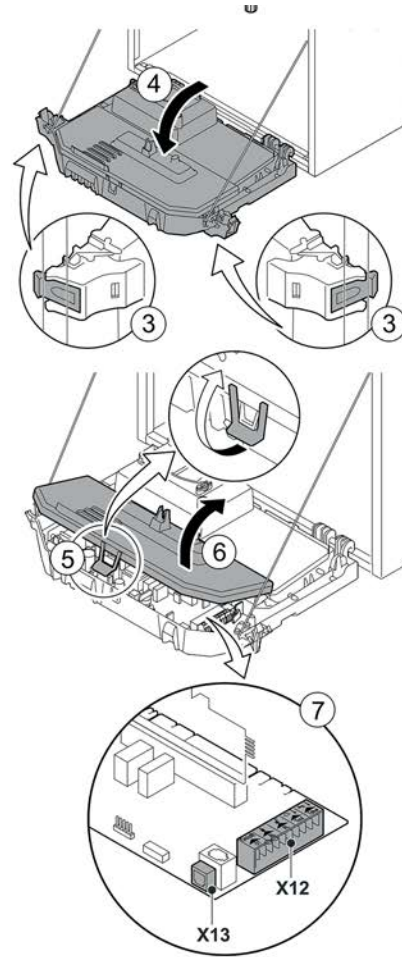
1. Unscrew two screws located on top of front panel. Remove panel.
2. Guide controller or thermostat wire through round grommet(s) on right side of boiler's bottom plate right.
3. Tilt control box forward by opening holding clips located on each side of boiler.
4. Open control panel cabinet by unfastening clip on front of control box. Push lip back for latch.
5. Run wire(s) through grommet(s) in control panel cabinet.
6. Unscrew wire clamp (to access connection block) and bring wires through.
7. Connect wires to appropriate terminals on connection block.
8. Firmly tighten wire clamps and close control panel cabinet.

Various thermostats and controllers can be connected to standard control PCB (X12 connection block).

### 8.5 Main Supply Connection

Main supply is connected to terminal block X1 which is high voltage (120V / 60Hz).

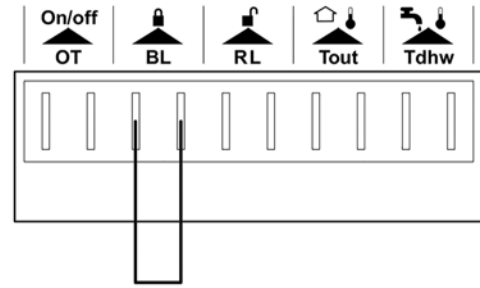
FIGURE 8-2 Remove Front Panel



## 8.6 Shutdown Input

- Boiler has a shutdown input, input is on **BL** terminals of control board.
- Only suitable for potential free contacts.
- When using this input remove jumper cable.
- Change input setting using **P36**. See parameter Settings page 56.

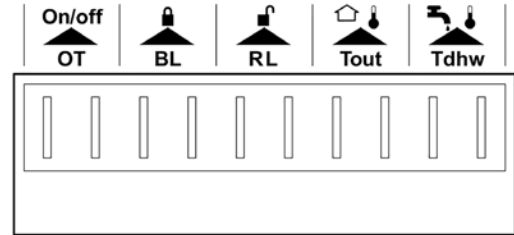
**FIGURE 8-3 Shutdown Input**



## 8.7 Release Input

- Boiler has release input, input is on **RL** terminals of connector.
- Change input setting using **P37**. See parameter Settings page 56.
- Only suitable for potential free contacts.

**FIGURE 8-4 Release Input**



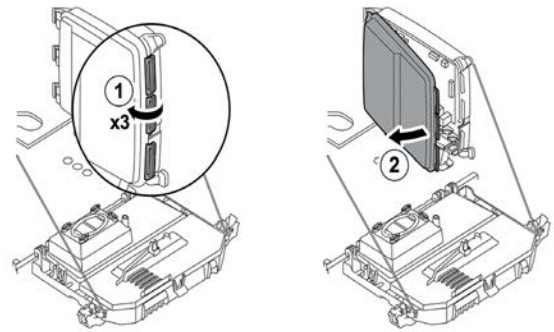
## 8.8 Optional Electrical Connections:

### Auxiliary Control Box

Control PCBs are located in auxiliary control box. See instructions provided with control PCB.

- Unclip PCB cover
- Remove cover

**FIGURE 8-5 Auxiliary Control Box**



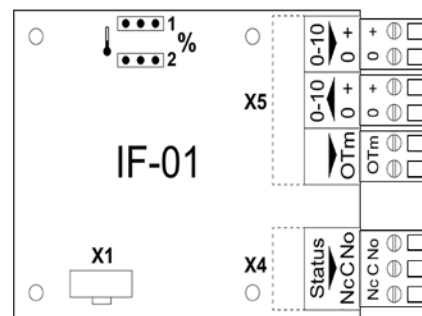
### Connection Options for 0-10V Control PCB (IF-01)

**IF-01** control PCB is built into auxiliary control box. Refer to instructions supplied with product.

**Do not** connect freeze thermostat or room thermostat to boiler if using 0-10 V control PCB.

- 1. Connection Status (Nc)** - If boiler locks out, a relay is de-energized and an alarm can be transmitted via a dry set of contacts (maximum 120 VAC-1A) on terminals **Nc** and **C** of the control board connection.
- 2. Connection Status (OTm)** - Interface communicates with boiler control using **Open Therm** protocol. OTm connection must be connected to **Open Therm** input OT of boiler control.
- 3. Analogue Input (0-10V)** - Control can be based on temperature or heat output. Two controls are described below. Analog control, 0-10 V signal must be connected to the interface.

**FIGURE 8-6 0-10V Control PCB (IF-01)**



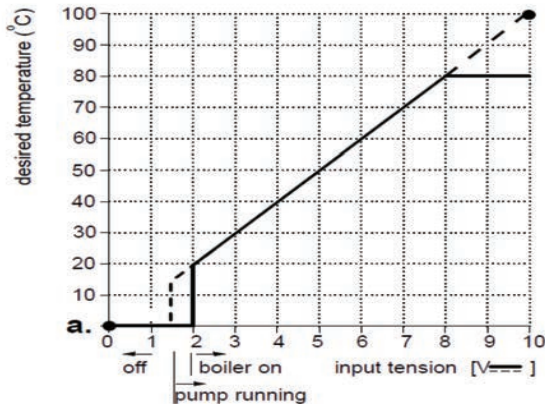


## 8 - ELECTRICAL CONNECTIONS

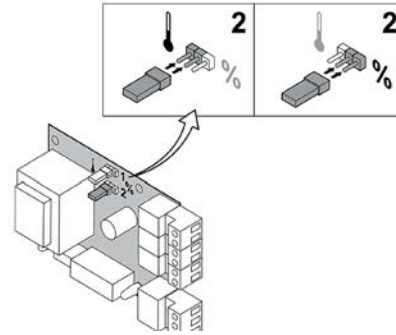
- 4. Analog Temperature-Based Control - 0 - 10 V** signal controls boiler supply temperature between 32°F (0°C) and 176°F (80°C). Control modulates on basis of supply temperature, heat output varies between minimum and maximum values based on supply temperature set point calculated by the controller. Jumper 2 on the interface is used to select either temperature control (🌡️) or heat output control (%).

**Temperature:**

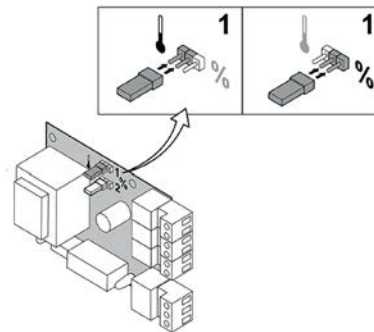
- 0,0 - 1,5 V = boiler off
- 1,5 - 1,8 V = boiler off, pump on
- 1,8 - 10 V = boiler on



**FIGURE 8-7 Analog Temperature Based Control**



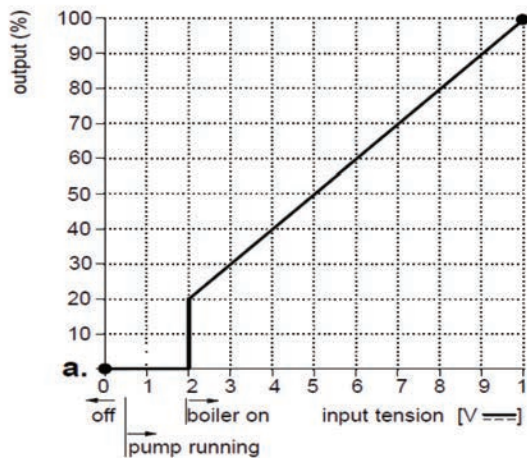
**FIGURE 8-8 Analog Output 0-10V**



- 5. Analog Heat Output - Based Control - 0-10V** signal controls boiler output between 0% and 100%. Minimum and maximum values are limited. Minimum output is linked to boiler's modulation depth. Output varies between minimum and maximum value on basis of value determined by controller.

**Capacity:**

- 0,0 - 2,0 V = boiler off
- 2,0 - 2,2 V = boiler off , pump on
- 2,0 - 10 V = desired output between minimum and maximum



Dependent on minimum modulation depth (set speeds, standard 20%)

- 6. Analog Output - 0-10V** - Temperature or heat output can be chosen for this feedback message. The two controls are described briefly below. Jumper 1 on the interface is used to select either temperature control (🌡️) or heat output control (%).

Jumper 1	Input Signal (V)	Temperature (°F/°C)	Description
🌡️	0	32-59 (0-15)	Boiler off
	0.5	59-72 (15-20)	Hysteresis
	2.0 - 10.0 <sup>1</sup>	72-176 (20-80)	Temperature required

<sup>(1)</sup> Dependent on minimum modulation depth (set speeds, standard 20%)

### Connection Option For PCB (SCU-S02)

If boiler is fitted with control PCB (SCU-S02) it will automatically be recognized by the automatic boiler control.

If removing this PCB boiler will show fault code E38. To prevent this fault, auto-detect must be done after removing the PCB. See Auto-Detect.

LED status indicator D3 top right of control PCB indicates status:


- Continuous signal: PCB working normally.
- Flashing signal: No connection.
- No signal: No voltage or faulty PCB (Check wiring).

**1. Heating System External Pump Control** - External pump for heating system can be connected to Pump terminals of control board. Maximum input power is 300 VA/ 0.4 FHP. Auxiliary relay must be used for pump with larger input.

**2. External Three-Way Valve (3WV) Control** - External three-way valve (120 VAC) can be used when connecting DHW indirect water heater. Neutral position of three-way valve can be set using parameter **P34**. Three-way valve is connected as follows:

- N = neutral
- C = heating system
- D = indirect tank

If neutral position of three-way valve is adjusted with parameter **P34** connect the pump as follows:

- N = N pump.
- C = L pump.
-  = Ground

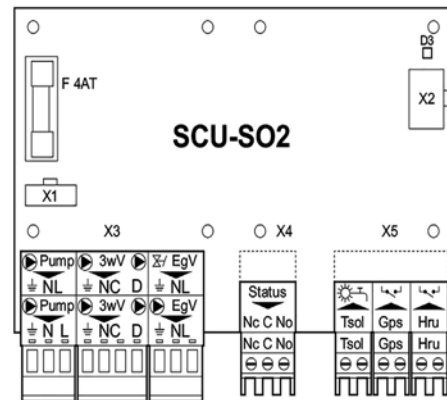
**3. External Gas Valve Control (EgV)**- If there is a call for heat, alternating voltage of 120 VAC, 1 A (maximum) becomes available on EgV terminals of control board to control an external gas valve.

**4. Operation Signal And Failure Signal (Status)**- Alarm or operation signal is selected using parameter **P40**.

- If boiler is operating, operation signal can be switched using dry set of contacts (maximum 120 VAC, 1 A) on **NO** and **C** terminals of the connection.
- If boiler locks out, alarm can be transmitted using dry set of contacts (maximum 120 VAC, 1 A) on **No** and **C** terminals of connection.

**5. Pressure Switch Minimum (GPS)** - minimum gas pressure switch shuts boiler down if inlet gas pressure becomes too low. Connect minimum gas pressure switch to Gps terminals. Presence of gas pressure switch must be set using parameter **P41**.

**FIGURE 8-9 Analog Output 0-10V**





Sensors supplied with this product are proprietary to the manufacturer. Use of after market sensors will result in diminished performance.

### 8.9 K Ohm (1K Ω) Outdoor Temperature Sensor

- Outdoor Temperature
- Flow Temperature

- P1** - Supply temperature (maximum)
- P25** - Supply temperature (minimum)
- P26** - "WWSD" (Warm Weather Shutdown)
- P27** - Outdoor temperature (default)

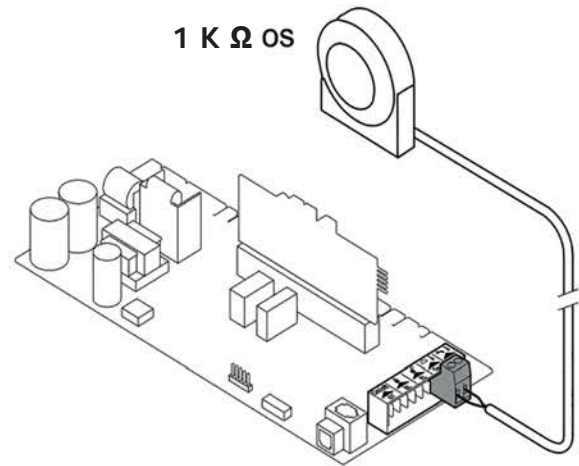
If outdoor temperature sensor is connected, heating curve can be adjusted. Setting can be modified using parameters - **P1**, **P25**, **P26** and **P27**.

- **Outdoor Sensor, if used.**
  - A. Provided with boiler.
  - B. Locate 1 K Ω outdoor sensor to protect against wind and direct sunlight. Mounting instructions provided with sensor.
  - C. Maximum wire length is 100 ft (30m) for 22 ga. wire, or 150 ft (45m) for 18 ga. wire.
  - D. Connect wires to OUTDOOR SENSOR terminals. Wires are interchangeable.
  - E. Outdoor temperature sensors are a boiler accessory. Where there is an on/off thermostat, boiler will control the temperature with set point of the internal heating curve.

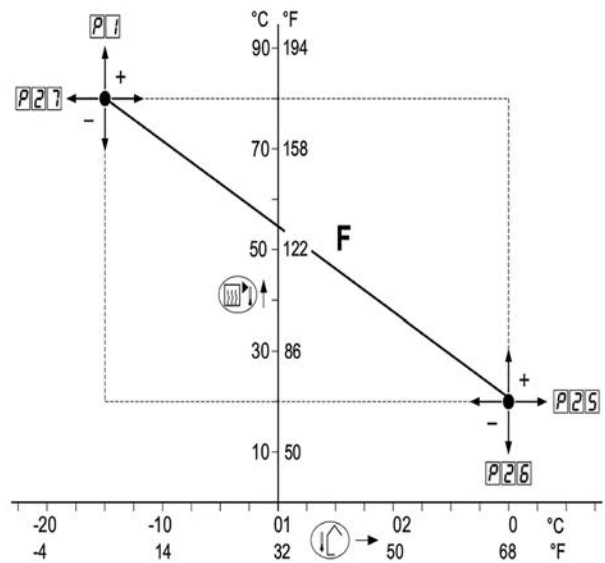
### 8.10 Central Heating Thermostat

- A. If a room thermostat with an anticipator is used, parameter **P5** must be adjusted.
- B. Install thermostat in frequently occupied room.
- C. Connect 2 wire dry contact room thermostat to ON/OFF-OT terminals of boiler's control board connection. **Note** :ON/OFF-OT terminals are NOT able to supply 24V to the thermostat.
- D. Use thermostat or boiler system control with dry contacts related 0.5 amps @ 120 VAC. Boiler control does **NOT** provide 24 VAC power to central heating thermostat.
- E. Locate and install thermostat per manufacturer's instructions. Maximum wire length is 330 ft (100m) for 22 ga. wire.
- F. Connect wires to on/off - OT terminals. Wires are interchangeable.
- G. Boiler is not suitable for Nest type thermostat without the use of an isolation relay, such as Argo IR-882.

**FIGURE 8-10 Outdoor Temp Sensor**



**FIGURE 8-11 1k Ω Outdoor Temp Sensor Chart**



Use dry contact for wires to On/Off OT terminal. **E33** error code is displayed if voltage is sent back to the control board. If error is not corrected for extended period of time, this voltage can permanently damage control board.

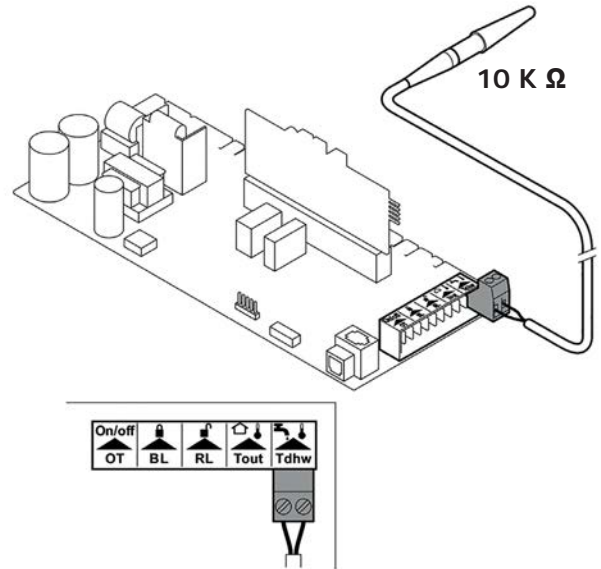


If room thermostat with anticipator is used, parameter **P5** must be adjusted.

**8.11 10 K Ω DHW Indirect Water Heater**

Connect 10 K Ω DHW indirect tank sensor or thermostat (TS) to "T dhw" terminals on control board.

**FIGURE 8-12 10 K Ω Indirect Water Heater Thermostat**



**8.12 Frost Protection**

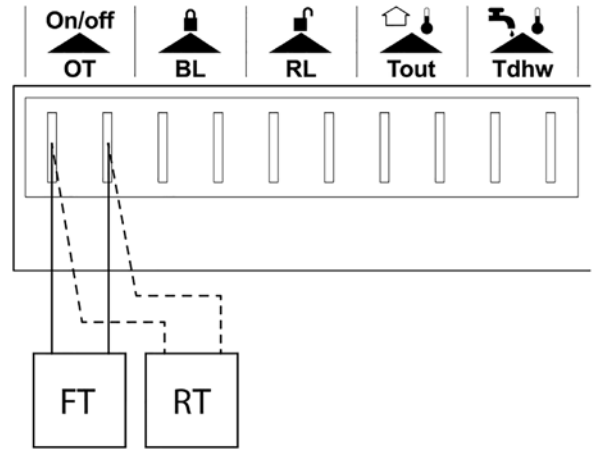
**Frost protection in combination with ON/Off thermostat.**

- If ON/Off thermostat is used, protect any rooms where there is a risk of freezing by using freeze thermostat (FT). Radiator valves or zone where there is risk of freezing must be open.
- Connect frost thermostat in parallel with On/Off room thermostat (RT) to ON/Off\_OT terminals of control board connection.

**Frost protection in combination with outdoor temperature sensor.**

- Heating system can be protected against freezing in combination with 1 K Ω outdoor temperature sensor. Radiator valve or zone must be open where there is a risk of freezing.
- Connect 1 K Ω outdoor temperature sensor to "T out" terminals of control board.
- Frost protection activates when 1 K Ω outdoor temperature sensor reads a temperature lower than 10°F (-10°C). This can be adjusted using parameter P30. Circulation pump will switch on and operate continuously until the outdoor temperature increases past value set on parameter P30.

**FIGURE 8-13 Frost Protection in Combination with ON/OFF Thermostat**



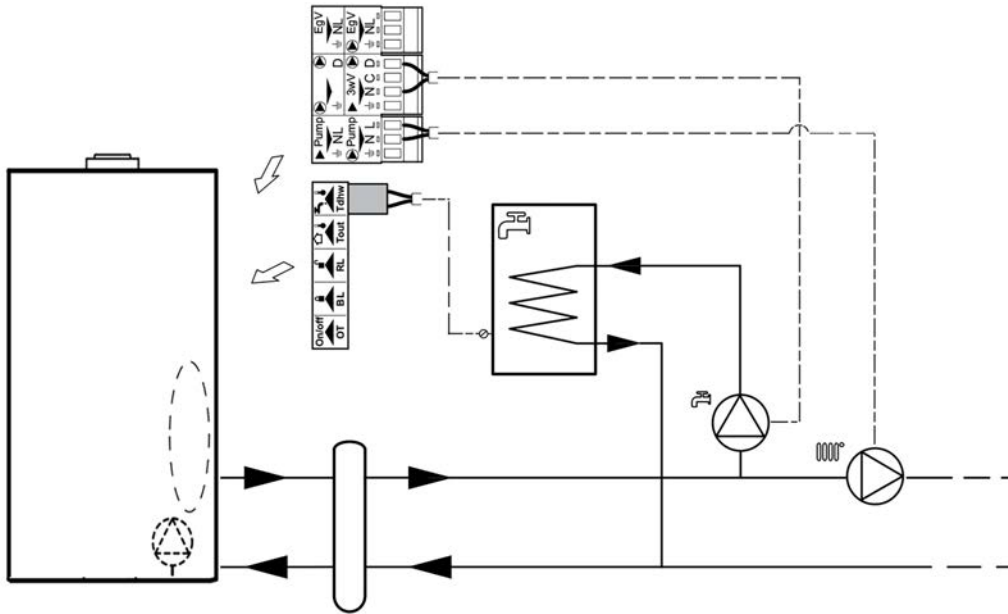
**8.13 Pump Anti-Seize Protection**

- If the boiler is in standby for 76 hours the pump will run 1 minute to prevent seizing.

## 8 - ELECTRICAL CONNECTIONS

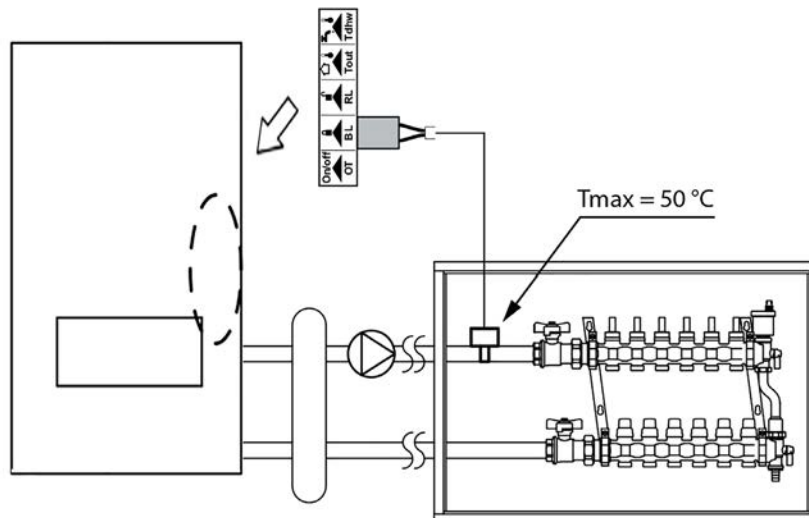
**FIGURE 8-14 Example Of Hydronic Circuit With DHW Indirect Water Heater**

- Connect Indirect tank sensor to **Tdhw** terminals as described in section 8.11.
- Connect CH (Central Heating) pump on terminal **N-L** "Pump" of control PCB (SCU-02) see section 8.8.
- Connect DHW (Domestic Hot Water) pump on terminal **N-D** "3wV" of control PCB (SCU-02) see section 8.8.



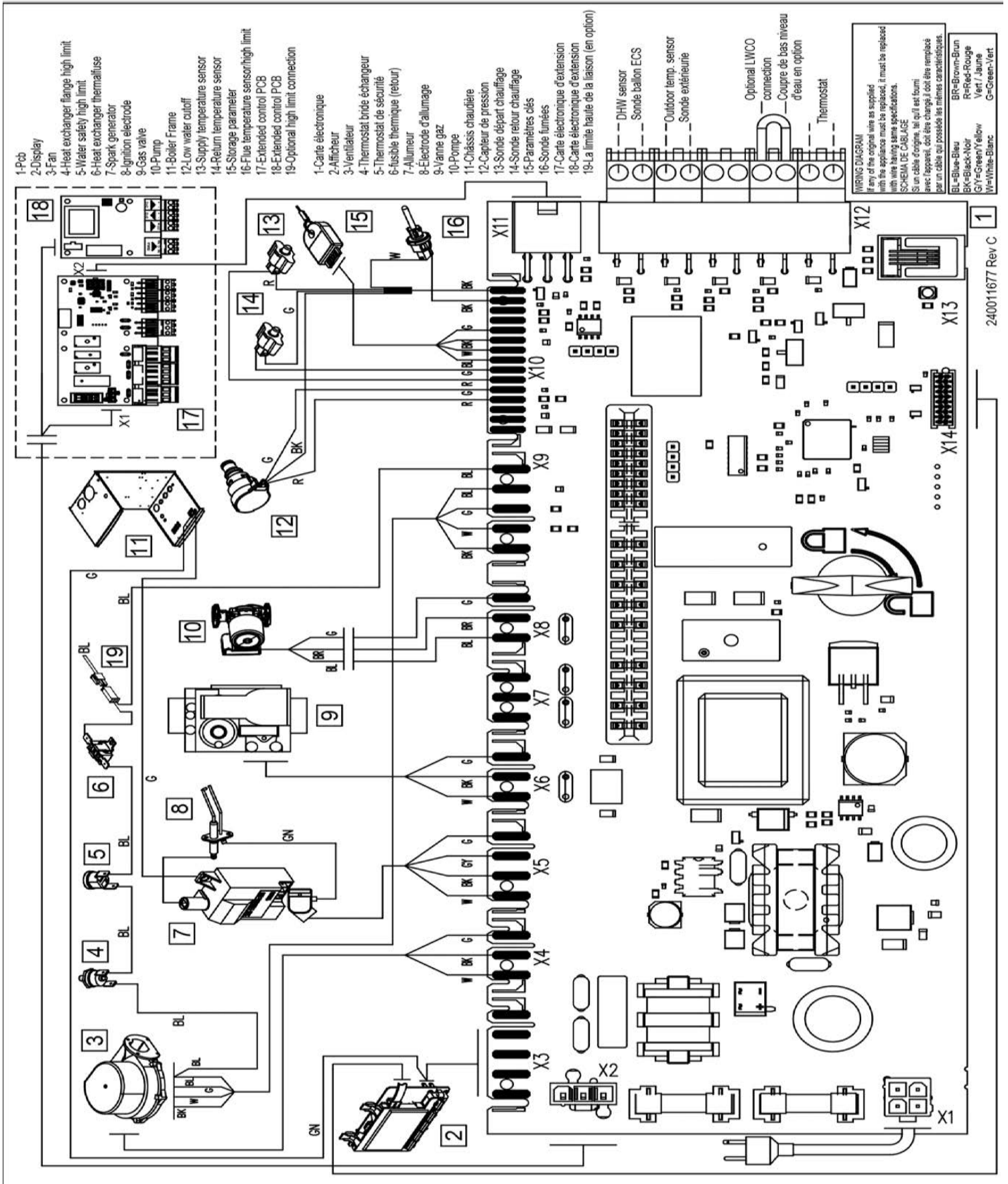
**FIGURE 8-15 Example Of System Shutdown Input Connection**

Example below shows connection of shutdown input for system connecting to auxiliary board. See section 8.6.



# 8 - ELECTRICAL CONNECTIONS

FIGURE 8-16 Wiring Diagram



240011677 Rev C

### 9.1 Fill Condensate Trap with Water

#### ⚠ WARNING

Asphyxiation hazard! Fill condensate trap before starting boiler to avoid combustion products escaping boiler. Failure to follow these instructions could result in death or serious injury.

- To fill the condensate trap pour water into exhaust vent until water begins to flow through the siphon.
- Visually inspect the siphon to ensure it is full with clean water.
- During operation check the condensate trap to ensure it is draining properly.

**Note** Condensate trap must be manually filled with water at initial start up.

### 9.2 Commission Setup (Water)

**Note** To maintain boiler efficiency and prevent boiling inside the heat exchanger, flush entire heating system until clean.

- Check distribution system to ensure it is sized and installed correctly.
- Before filling, open all valves on the heating circuit in the installation.
- Flush heating system, including all heating zones.
- Fill boiler with potable water.
- Fill boiler and system piping with water (or antifreeze-water solution, if used). See antifreeze information page 11. Purge air from boiler using air vent. Purge air from system piping.
- Close air vent after all air is purged from both boiler and system piping.
- Inspect system piping and boiler connections. Repair any leaks immediately.
- Check water pressure gauge is between 14.7-22.1 psi ( 1-1.5 bar) when system water temperature is cold. If pressure is lower turn water off. Turn water on and restart the filling process very slowly to vent air. System must be turned on to read pressure from display.
- Boiler is equipped with hydraulic pressure switch which prevents boiler from operating without water.
- Check there are no leaks from any water connections.

**FIGURE 9-1 Condensate Drain Assembly**

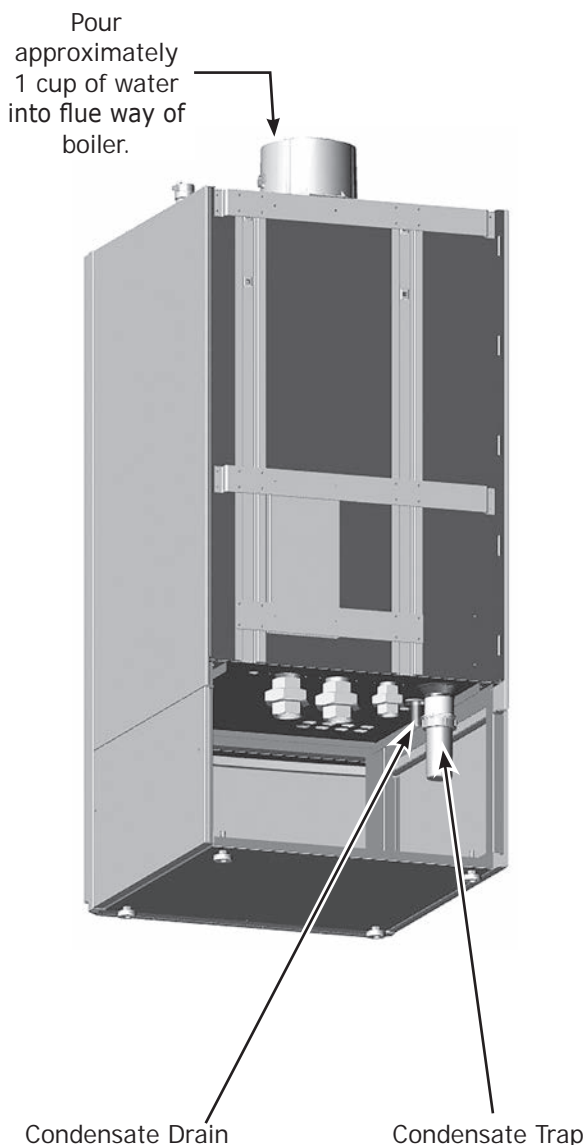
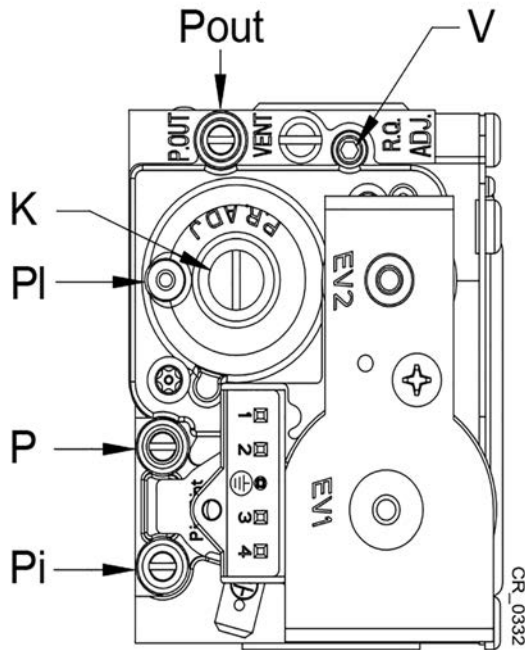


FIGURE 9-2 Gas Valve



**WARNING**

Fire, explosion, and asphyxiation hazard! Boiler is set for natural gas from the factory. If propane is to be used the gas valve must be adjusted before turning boiler on. Failure to follow these instructions could result in death or serious injury.

**9.3 Commission Setup (Gas)**

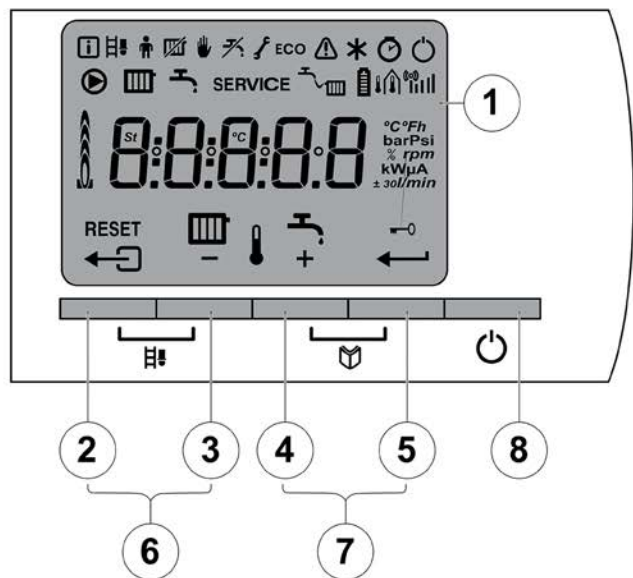
1. Check gas type supplied matches data shown on boiler's rating plate.
2. Check gas piping to ensure it is sized and installed correctly.
3. Visually inspect piping to determine there are no open fittings or ends, and all valves at unused outlets are closed and plugged/capped.
4. Purge air from piping. Confirm there is a steady gas supply to the boiler.
5. Open main gas supply.
6. Open gas shutoff valve on boiler.
7. Unscrew two screws located on top of front panel, remove the panel.
8. Tilt control box forward by opening holding clips located on each side of the boiler.
9. Check gas supply pressure at t pressure outlet "Pi" on gas valve unit.
10. Ensure all gas connections are tight.
11. Pressure test the gas line:
  - A. Test pressure must not exceed 0.87 psig/60 mbar.
  - B. Purge gas supply pipe within boiler by unscrewing pressure outlet on gas valve.
  - C. Tighten the port when pipe has been sufficiently purged.
12. Check all gas connections in the boiler are tight.
13. Check piping and connections for leaks immediately after gas is turned on. Shut off gas supply and make necessary repairs if leaks are found.

**9.4 Commission Setup (Electric)**

1. Check electrical connections to thermostat and other external controls. Check any other connections to boiler.
2. Check all electrical connections, particularly the ground connection.
3. System test pumps - verify each pump is operational using vibration, noise and amp draw.



9.5 Control Panel



1	Display
2	[Escape] or RESET button
3	Heating Temperature or [-] button
4	DHW temperature or [+] button
5	[Enter] or cancel  lock-out button
6	Setup buttons (press the 2 and 3 buttons simultaneously)
7	[Menu] buttons (press the 4 and 5 buttons simultaneously)
8	ON/OFF switch

Symbols


	<b>Information menu:</b> Reading the various current values
	<b>Chimney-sweeping position:</b> Forced full or part load for CO2 measurement.
	<b>User menu:</b> Parameters at user level can be changed.
	<b>Heating program deactivated:</b> The heating function is deactivated.
	<b>Manual mode:</b> Boiler is set to manual operation.
	<b>DHW program deactivated:</b> DHW mode is deactivated.
	<b>Service menu:</b> Parameters at installer level can be changed.
<b>ECO</b>	<b>Energy-saving mode:</b> Economic mode activated.
	<b>Fault:</b> Boiler fault indicated. Can be seen from é code and red display.
	<b>Frost protection:</b> Boiler running in frost protection mode.
	<b>Hour counter menu:</b> Readout of operating hours, number of successful starts and hours on main supply.

	<b>ON/OFF switch:</b> After 5 lock-outs, boiler must be switched OFF/ON again.
	<b>Boiler pump:</b> Pump operates
	<b>Heating system function:</b> Access to heating system temperature parameter.
	<b>DHW function:</b> Access to potable hot water temperature parameter.
<b>SERVICE</b>	<b>Yellow display with symbols:</b> + service + <i>A</i> (Maintenance message).
	<b>Water pressure:</b> Water pressure is too low.
	<b>Burner Level:</b> Boiler is running at full or low load.
	<b>Locking keys:</b> Key lock-out is activated.


9.6 Deaeration Function

**Note** Control performs the Deaeration function at initial start and after a reset of a locking error and after power up.

Before starting boiler deaeration function **must** be performed.

Rotate black cap on deaerator, located on the top of the boiler, counter clockwise  to ensure aerator is open.

- When power is supplied to the boiler Deaeration function starts.
- Display shows **17** (Deaeration) and water pressure (Psi). See Figure 9-4.
- Boiler pump will run on and off for up to 10 minutes. This will purge air from the system.
- The burner will switch on for a few seconds to verify increasing temperature on flow/return sensors.
- Boiler is ready to start in standard operation.

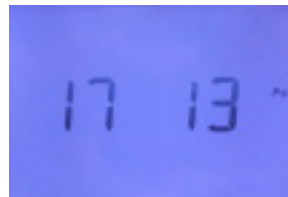
Repeat Deaeration function at least 3 times switching boiler on off using  button.

**FIGURE 9-3 AERATOR**

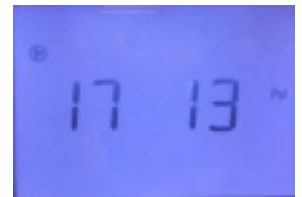


AERATOR - LOCATED ON TOP OF BOILER

**FIGURE 9-4 Deaeration Function Display Readout**



Pump OFF



Pump ON

9.7 Commissioning

- Tilt control box upwards. Fasten with clips located at the sides.
- Open main gas supply.
- Open gas shutoff valve on boiler.
- Plug boiler into an electrical socket.
- Turn boiler on using ON/OFF switch.
- Set controls (thermostats, control system) to generate a call for heat.
- **Start-up cycle begins, this cannot be interrupted.**  
During start-up cycle, display shows following information:  
A short test where all segments of the display are visible.

**Fxx** : Software version

**Pxx** : Parameter version. Version numbers are displayed alternately.

- Air purge cycle is automatically carried out for 3 minutes.

9.8 Before Gas Conversion

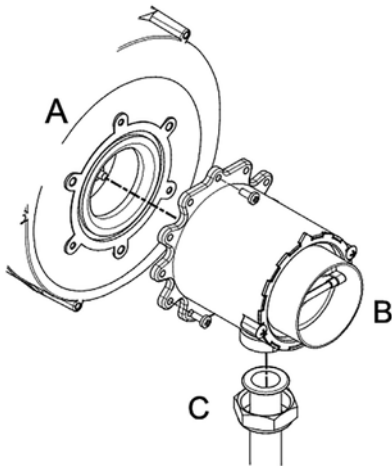
When converting from natural gas (A) to propane gas (E), before calibrating gas valve, replace venturi assembly (B) as indicated in figure 9-5.

Disconnect gas pipe (threaded nut "C") and remove three screws securing the flange.

Verify there are no gas leaks.

Natural Gas				Propane			
Venturi		Nozzle		Venturi		Nozzle	
in	mm	in	mm	in	mm	in	mm
1 3/16	30	7/32	5.3	1.18	30	5/32	4

FIGURE 9-5 Venturi and Nozzle



9.9 Gas Conversion (Propane)

Boiler is preset to operate on natural gas (A).

For operation with propane gas, carry out following:

1. Activate "Calibration function" to set boiler to operate on full load and on part load in Heating mode.
2. Adjust Fan Speed as indicated in table found in section "Parameter Settings" (if required).
3. Modify fan speeds using parameters **P17**, **P18** and **P19**.
4. Set air/gas ratio (O<sub>2</sub> /CO<sub>2</sub> %): Full load and Part load as describe below.
5. Use combustion analyzer to properly set gas valve.
6. Allow time between adjustments for your combustion analyzer to sense adjusted CO<sub>2</sub> /O<sub>2</sub> level. This function is interrupted if the central heating supply temperature reaches its MAX. SETPOINT.

To measure combustion efficiency and emissions of products of combustion, boiler has two dedicated built in test ports.

One connection port is connected to exhaust flue (A), and allows monitoring of the quality of combustion products and combustion efficiency.

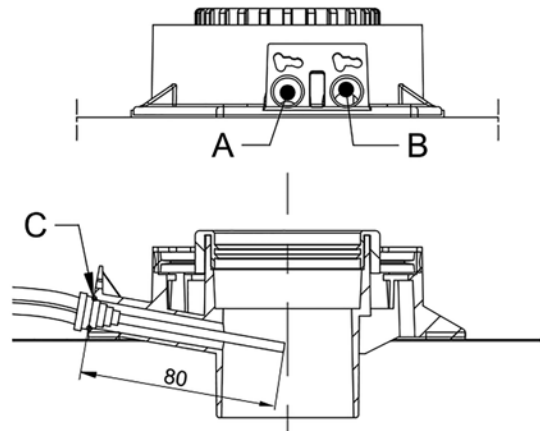
Other is connected to combustion air intake (B), used to check for recycling products for combustion.

The following can be measured at exhaust flue test port:



- temperature of combustion products
- oxygen (O<sub>2</sub>) or carbon dioxide (CO<sub>2</sub>) concentration;
- carbon monoxide (CO) concentration.

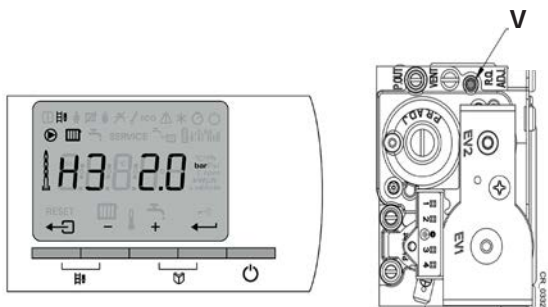
The temperature of combustion air must be measured on the air intake test port (B) by inserting the measurement sensor approximately 3-3/16" (80.00 mm) (C) for the DMG-240.

FIGURE 9-6 Combustion Air Temperature Ports



9.10 Combustion Setup (High-Fire)

- Remove exhaust port plug at exhaust flue test port.
- Insert combustion analyzer into exhaust flue test port. Verify the opening around combustion analyzer probe is completely sealed when taking measurements.
- Set boiler to high-fire by pressing two buttons  simultaneously. Display will show **H3** and the symbol  will appear.
- Measure percentage of O<sub>2</sub> or CO<sub>2</sub> in flue gases.
- Compare the measured values with values in table below.
- Adjust gas/air ratio using high-fire adjustment screw (**V**) if needed. Turn screw clockwise to reduce CO<sub>2</sub> level and counterclockwise to increase it.




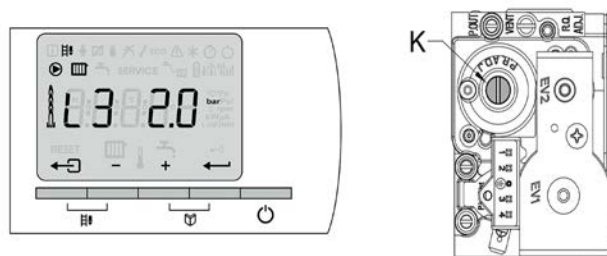
CO <sub>2</sub> Values Natural Gas (A) at High Fire		
Front Panel	CO <sub>2</sub> %	
	Nominal	Range
ON	9.3	9.1 - 9.5
OFF*	8.9	8.5 - 9.0

CO <sub>2</sub> Values Propane Gas (E) at High Fire		
Front Panel	CO <sub>2</sub> %	
	Nominal	Range
ON	10	9.8 - 10.2
OFF*	9.6	9.2 - 9.7

\* Installer's guide only. Use test port to verify safe CO levels with door installed before leaving job site.

9.11 Combustion Setup (Low-Fire)

- Remove exhaust port plug at exhaust flue test port.
- Insert combustion analyzer into exhaust flue test port. Verify the opening around combustion analyzer probe is completely sealed when taking measurements.
- Set boiler to low-fire by pressing two buttons  simultaneously. If the boiler is already in combustion setup mode for high fire, press the (-) button several time until **L3** is displayed on the screen.
- Measure percentage of O<sub>2</sub> or CO<sub>2</sub> in flue gases.
- Compare the measured values with values in table below. Remove front panel when comparing values.
- Adjust gas/air ratio using low-fire adjustment screw (**K**) if needed. Turn screw clockwise to increase CO<sub>2</sub> level and counterclockwise to decrease it.



O <sub>2</sub> /CO <sub>2</sub> Values at Low-Fire Natural Gas (A)			
Nominal value		Permitted value	
O <sub>2</sub> %	CO <sub>2</sub> %	O <sub>2</sub> %	CO <sub>2</sub> %
4.8	9	4.5 - 5.2	8.8 - 9.2

O <sub>2</sub> /CO <sub>2</sub> Values at Low-Fire Propane Gas (E)			
Nominal value		Permitted value	
O <sub>2</sub> %	CO <sub>2</sub> %	O <sub>2</sub> %	CO <sub>2</sub> %
6.4	9.6	6.1 - 6.70	9.4 - 9.8

9.12 Operational Check

- Inspect combustion air and vent piping. Verify pipe is not leaking and terminations are unobstructed. Verify vent gas discharge is not a nuisance or hazard.
- Verify boiler functions.
- Inspect condensate disposal system. Verify condensate flows adequately and is disposed properly.
- Check control module operation.
- Check field sourced limits, low water cutoffs, etc. per manufacturer's instructions.

9.13 User Level Parameters

Parameters **P1** to **P8** can be adjusted by end user to meet heating system and DHW comfort needs.

Modification of factory settings may be detrimental to operation of the boiler.







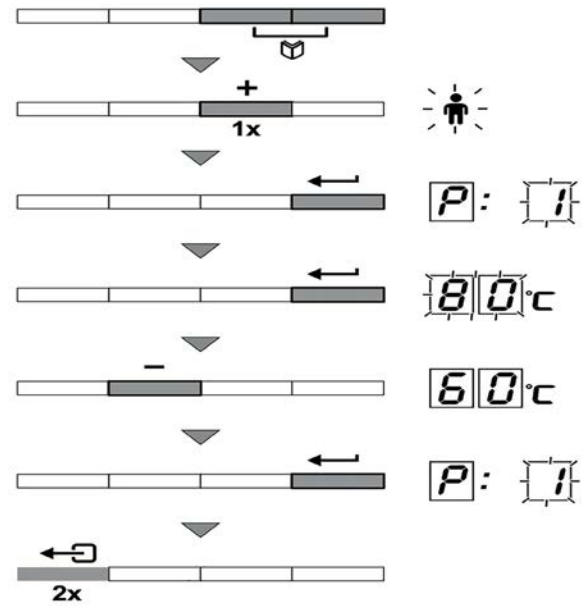
- Press the two Menu buttons  simultaneously and then (+) button until  symbol flashes on the menu bar.
- Select the user menu using  button, (P1) button is displayed with "1" flashing.
- Press  button a second time, the central heating supply temperature value appears and flashes, for example 80°C (176°F).
- Change the value by pressing (-) button or (+) button. In this example using (-) to 60°C (140°F).
- Confirm the value with  button, (P1) is displayed with "1" flashing.
- Press  button 2 times to return to current operating mode.

FIGURE 9-7 - User Level Parameters



9.14 Installer Level Parameters

Parameters **P17** to **dF** (error code history) must only be modified by a qualified installer.

To prevent unwanted settings, some parameter settings can only be changed after special access code **0012** is entered.

Modification of factory settings may be detrimental to operation of the boiler.








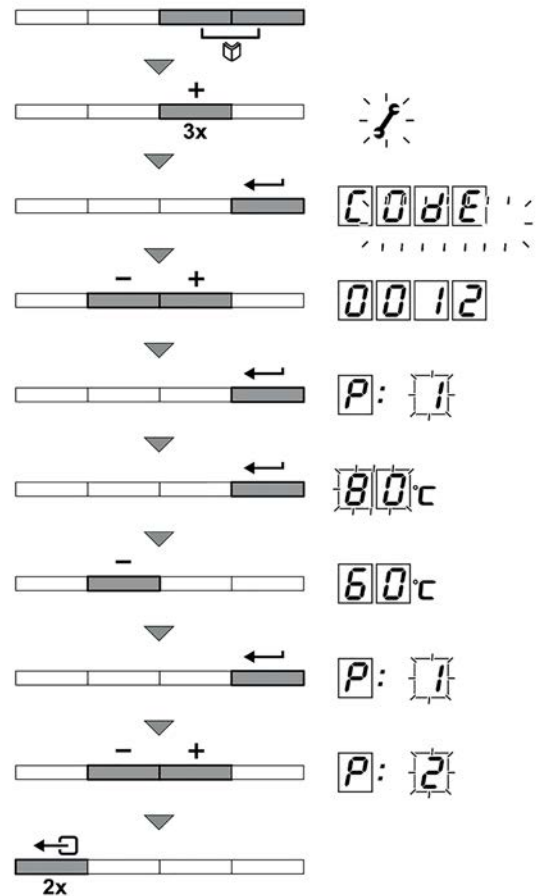
- Press the two Menu buttons  simultaneously and then (+) button until the symbol  flashes on the menu bar.
- Select the INSTALLER menu using the  button. "CODE" appears on the display.
- Use (-) or (+) button to input the installer code "0012".
- Confirm using  button, "P1" is displayed with "1" flashing.
- Press  button a second time, the value will appear and flashes, for example [80°C (176°F)].
- Change the value by pressing the [-] or [+] button. [In this example using [-] button to change the value to 60 °C (140 °F).]
- Confirm the value with the  button, "P1" is displayed with 1 flashing. Button, "P1" is displayed with 1 flashing. If necessary, set other parameters by selecting them using the (-) or (+) button.
- Press  button 2 times to return to current operating mode.

FIGURE 9-8 - Installer Level Parameters



## 9 - START UP PROCEDURE

### 9.15 Parameters Settings

Boiler control panel is set for most common heating systems. With these settings, most heating systems operate correctly; however, installer can adjust parameters according to their own preferences.

Parameter	Description	Adjustment Range	Factory Setting
			DMG-380
P1	Max flow temperature during CH mode (Set temperature)	68 to 194°F 20 to 90°C	176°F/80°C
P2	Desired DHW temperature	104 to 149°F 40 to 65 °C	140°F/60°C
P3	Switch on/off CH/DH function	0 = Heating off / DHW off 1 = Heating on / DHW on 2 = Heating on / DHW off 3 = Heating off / DHW on	2
P4	Keeping warm for DHW comfort	0 = Always on 1 = Always off 2 = Controller	2
P5	Anticipation current on/off thermostat	0 = No 1 = Yes	0
P6	Amount of information on display	0 = Simple 1 = Extended 2 = Automatic	1
P7	Pump post run time CH	1 to 98 minutes 99 minutes = continuous	3
P8	Display brightness when backlight is active	0 = Low 1 = High	1
P17	Max fan speed during CH mode	Natural gas(1) (x100 rpm)	73
		Propane (x100 rpm)	71
P18	Max fan speed during DHW mode	Natural gas(1) (x100 rpm)	73
		Propane (x100 rpm)	71
P19	Minimum fan speed during CH + DHW mode	Natural gas(1) (x100 rpm)	12
		Propane (x100 rpm)	12
P20	Offset on part load fan speed	Natural gas(1) (x100 rpm)	0
		Propane	0
P21	Fan speed at the boiler start	(x100 rpm)	30
P22	Minimum water pressure for notification	5 = 7.3 psig/0.5 bar	5
P23	Maximum flow temperature for heating system	32 to 190°F 0 to 88°C	68°F/20°C
P24	Hysteresis anticycle CH	5 to 59°F -15 to 15°C	68°F/20°C
P25	Maximum outdoor temperature (for use with an outdoor temperature sensor only)	32 to 86°F 0 to 30°C	241
P26	Footpoint heating curve flow temperate Maximum outdoor temperature (for use with an outdoor temperature sensor	32 to 194°F 0 to 90°C	68°F/20°C

## 9 - START UP PROCEDURE

### Parameters Settings - Continued

Parameter	Description	Adjustment Range	Factory Setting
			DMG-380
P27	Clima point heating curve outside temperature (Only with an outdoor temperature sensor)	-22 to 32°F -30 to 0°C 241= 5°F/-15°C	241
P28	Pump control, CH minimum speed	2 - 10 (x 10 %)	7
P29	Pump control, CH maximum speed	2 - 10 (x 10 %)	10
P30	Minimal outside temperature for frost protection	-22 to 32° -30 to 0°C 246= 14°F/-10°C	246
P31	Legionella protection calorifier	0 = No 1 = Yes 2 = Controller	1
P32	Set point raise at warming up calorifier	32 to 77°F 0 to 25°C	68°F/20°C
P33	Switch on hysteresis calorifier sensor	35.6 to 59°F 2 to 15°C	41°F/5°C
P34	3 way valve stand by: CH or DHW	0 = CH 1 = DHW	0
P35	Boiler type and control type	0 = Solo (+boiler) 1 = Process heat	0
P36	Function of blocking input	0 = CH enable 1 = Blocking without frost protection 2 = Blocking with frost protection 3 = Lock-out with frost protection	1
P37	Function of release input	0 = DHW enable 1 = Burner release	1
P38	Wait time for valid release signal	0 to 255 seconds 0 = No check	0
P39	Wait time for flue gas valve	0 to 255 seconds	0
P40	Position from alarm/operation signal relays	0 = Operation signal 1 = failure signal	1
P41	Minimum gas pressure detection	0 = no 1 = yes	0
P42	HRU connected	0 = no 1 = yes	0
P43	Mains L-N phase detection activated	0 = No 1 = Yes	0
P44	Service notification for boiler dependent maintenance	0 = Off 1 = ABC 2 = Custom	0
P45	Service hours for boiler connected to mains supply	1 to 255 (x 100h)	175
P46	Service hours for boiler burner	1 to 255 (x 100h)	30

## 9 - START UP PROCEDURE

### Parameters Settings - Continued

Parameter	Description	Adjustment Range	Factory Setting
			DMG-380
P47	Modulate back when dT > this parameter	41 to 140°F 5 to 60°C	140°/60°C
P48	DHW stabilization time	10 to 100 seconds	30
P49	Display units	0 = Metric 1 = Imperial	1
P50	Factor for average flow temperature calculation	1 to 255 seconds	1
P51	Flue gas temperature	0 = PVC 65°C / 149°F 1 = CPVC 90°C / 194°F 2 = PP/SS 110°C / 230°F	1
P52	Air pressure sensor	0: Off 1: On	0
P53	DHW time out mode	0: None 1: Absolute	1
P54	DHW time out	10 to 180 minutes	150
P55	CH prior time	10 to 180 minutes	120
P56	RPM min antiwind	10 to 30 (*100rpm)	25

(1) Do not modify these factory settings unless absolutely necessary. Example : to adapt the boiler to: Propane (gas E)

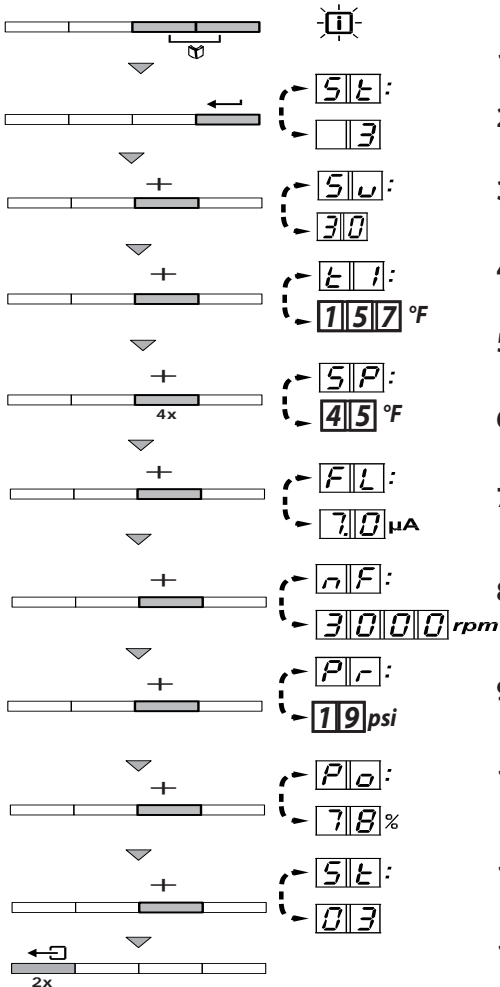


9.16 Reading Measured Values

The following current values can be read from the information menu **i**.

- **St** = State
- **Su** = Sub-status
- **t1** = Supply temperature °F/°C
- **t2** = Return temperature °F/°C
- **t3** = DHW tank temperature °F/°C
- **t4** = Outdoor temperature °F/°C (Only with an outdoor temperature sensor: Optional)
- **t5** = Solar boiler temperature °F/°C t6 = Flue gas temperature °F/°C Sp = Internal set point °F/°C
- **Fl** = Ionization current (µA)
- **ñf** = Fan speed in rpm
- **Pr** = Water pressure psig/bar
- **Po** = Supplied relative heat output (%).

Reading the Current Values



1. Press the two **i** buttons simultaneously. The symbol **i** flashes.
2. Confirm using **←** button. **St** is displayed alternating with current status 3 (for example).
3. Press the **[+]** button. **Su** is displayed, alternating with the current sub-status **30** (for example).
4. Press the **[+]** button. **t1** is displayed, alternating with the current flow temperature **157.0 °F** (for example).
5. Press the **[+]** button successively to scroll down to the various parameters. **t2**, **t3**, **t4**, **t5**, **t6**
6. Press the **[+]** button. **Sp** is displayed, alternating with the internal set point **45.0 °F** (for example).
7. Press the **[+]** button. **Fl** is displayed, alternating with the current ionization current **7.0 µA** (for example).
8. Press the **[+]** button. **ñf** is displayed, alternating with the current fan rotation speed **3000 rpm** (for example).
9. Press the **[+]** button. **Pr** is displayed, alternating with the current water pressure **19 psi** (for example).
10. Press the **[+]** button. **Po** is displayed, alternating with the current modulation percentage **78%** (for example).
11. Press the **[+]** button. The readout cycle starts again with **St**.
12. Press the **←** button 2 times to return to the current operating mode.








## 9 - START UP PROCEDURE

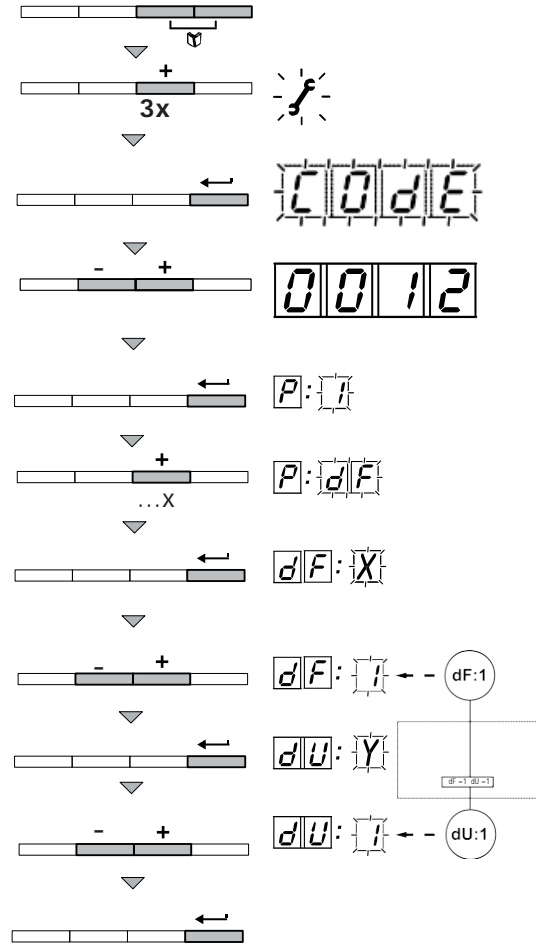
### 9.17 Status And Sub-Status

The information menu **i** gives the following status and sub-status information:

State (St)		Sub-status (Su)	
0	Rest	0	Rest
1	Boiler starts (Demand for heat)	1	Short pre-purge of the fan
		2	Control three-way valve
		3	Start pump
		4	sw checks sensor temperatures before the burner starts
2	Burner start	10	Open flue gas damper/external gas valve
		11	Increase fan speed
		13	Pre-purge
		14	Wait for release signal from RL connection
		15	Burner on
		17	Pre-ignition
		18	Ignition
		19	Flame detection
		20	Intermediate ventilation
3	Burner on (heating mode)	30	Temperature control
		31	Limited temperature control ( $\Delta T$ safety)
		32	Output controlled by 0-10 v signal
		33	Temperature protection gradient level 1 (Modulate down)
		34	Temperature protection gradient level 2 (low-fire)
		35	Temperature protection gradient level 3 (Blockage)
		36	Modulate up for flame control
		37	Temperature stabilization time
		38	Cold start
4	Burner on (DHW mode)	30	Temperature control
		31	Limited temperature control ( $\Delta T$ safety)
		32	Output controlled
		33	Temperature protection gradient level 1 (Modulate down)
		34	Temperature protection gradient level 2 (low-fire)
		35	Temperature protection gradient level 3 (Blockage)
		36	Modulate up for flame control
		37	Temperature stabilization time
		38	Cold start
5	Burner stop	40	Burner off
		41	Post-purge
		42	Close flue gas damper/external gas valve
		43	Recirculation protection (checks to see if gas valve has closed)
		44	Fan Stops
6	Boiler stops (End of heat call)	60	Pump post circulation
		61	Pump off
		62	Control three-way valve
		63	Short-cycling counter activates
8	Stop	0	Wait for burner start
		1	Short cycling protection function
9	Lock-out	xx	Shutdown codexx
17	Deaeration/ air purge	0	Rest
		2	Control three-way valve
		3	Start pump
		61	Pump off
		61	Control three-way valve

9.18 Return To The Factory Settings:

- Press the two Menu buttons  simultaneously and then (+) button until  symbol flashes on the menu bar.
- Select the **INSTALLER** menu using . "COdE" appears on the display.
- Use (-) or (+) button to input the installer code "0012".
- Confirm using  button. P:1 is displayed with 1 flashing.
- Press the [+] button several times p:df is displayed with df flashing.
- Press  button df:x is displayed with x flashing. This is the current value of X for dF. Check this against the value of X on the type plate.
- Enter the value of X shown on the type plate using the [-] or [+] button.
- Confirm the value with the  button, df:y is displayed with y flashing. This is the current value of Y for dU. Verify the value of y on the rating plate is the same.
- Enter the value of y shown on the rating plate using the [-] or [+] button.
- Confirm value with the  button. The factory settings are reset.
- Display returns to current operating mode.



FOR YOUR SAFETY READ BEFORE OPERATING

**⚠ WARNING**

**If you do not follow these instructions exactly, a fire or explosion may result causing property damage, personal injury or loss of life.**

- This appliance is equipped with an ignition device which automatically lights burner. **Do NOT try to light this burner by hand.**
- Before operating smell all around appliance area for gas. Be sure to smell next to floor because some gas is heavier than air and will settle to the floor.
- **Use only your hand to turn the gas shutoff valve.** Never use tools. If valve will not turn by hand, do not try to repair it, call a qualified service technician. Force or attempted repair may result in fire or explosion.
- **Do not use this appliance if any part has been under water.** Immediately call a qualified service technician to inspect appliance and to replace any part of control system and any gas control which has been under water.

**10.1 SEQUENCE OF OPERATION**

- With demand for heat, pump circulates water through primary circuit.
- Combustion fan will come on and begin to operate at ignition speed.
- Once fan reaches ignition speed, control board will allow power to flow to spark generator and gas valve creating ignition in combustion chamber. Flame sensor will acknowledge presence of flame in combustion chamber and send a signal to control board.
- Temperature sensor will send signal to control board allowing the control board to increase / decrease speed of the fan. The combustion fan will in turn modulate gas rate accordingly.
- Once central heating loop temperature exceeds central heating loop setpoint unit will shutdown and go through 3 minute time delay (burner pause time) before another call for heat.
- During this time the pump will run for additional three minutes to dissipate any residual heat.

**10.2 OPERATING INSTRUCTIONS**

**Stop! Read Safety information above.**

- Set thermostat to lowest setting.
- Turn "OFF" all electrical power to appliance.
- This appliance is equipped with an ignition device which automatically lights the burner. **Do not try to light burner by hand!**
- Turn gas shutoff valve to closed position. Handle should be perpendicular to gas pipe.
- Wait 5 minutes for any gas to clear. Smell for gas, including near floor. If you smell gas, **STOP!** Follow instructions on this page: **"What To Do If You Smell Gas."** If you do **not** smell gas, go to next step.
- Turn gas shutoff valve to the open position. Handle should be parallel to gas pipe.
- Turn "ON" electrical power to appliance.
- Set thermostat to desired setting.
- If the appliance will not operate, follow instructions TO TURN OFF GAS TO APPLIANCE and call your service technician or gas supplier.

**⚠ CAUTION**

**WHAT TO DO IF YOU SMELL GAS**

- Do not try to light any appliance.
- Do not touch any electrical switch; do not use any phone in your building.
- Immediately call your gas supplier from a neighbor's phone. Follow the gas supplier's instructions.
- If you cannot reach your gas supplier, call the fire department.

**10.3 TO TURN OFF GAS TO APPLIANCE**

- Set thermostat to lowest setting.
- Turn "OFF" all electric power to appliance if service is to be performed.
- Turn gas shutoff valve handle to closed position. Handle should be perpendicular to gas pipe.

**⚠ DANGER**

Before servicing, turn off electrical power to boiler at service switch. Close manual gas valve to turn gas supply OFF to boiler. Failure to comply will result in death or serious injury.

**⚠ CAUTION**

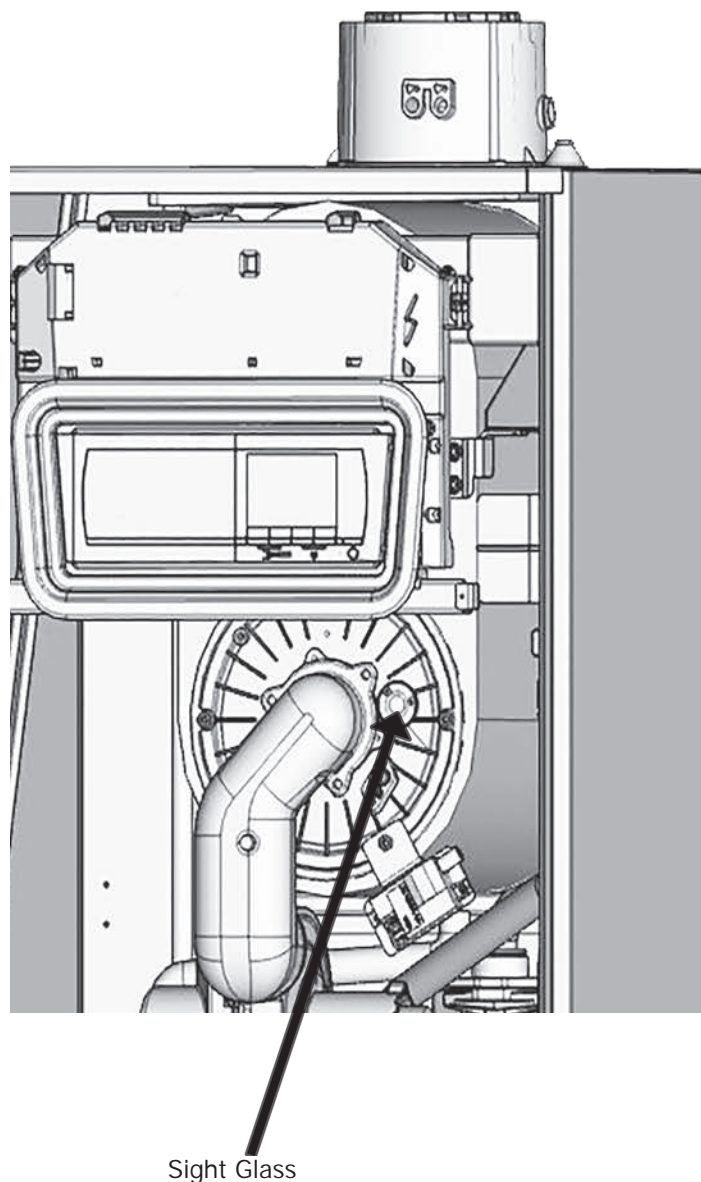
Label all wires prior to disconnection when servicing controls. Wiring errors can cause improper and dangerous operation.

**Note** Verify proper operation after servicing.

**Note** Perform regular service and maintenance by qualified service agency at least once every 12 months to assure safe, trouble free operation and maximum efficiency.

**11.1 Beginning of Each Heating Season**

- Check boiler area is free from combustible materials, gasoline, and other flammable vapors and liquids.
- Visually inspect combustion air and vent piping for proper operation. Check for and remove any obstruction to flow of combustion air or vent gases. Immediately repair or replace pipe showing deterioration or leakage. Reassemble per instructions in section 6. Ensure proper reassembly and resealing of system.
- Visually inspect condensate drain line for proper operation. Checking for deteriorated or plugged condensate drain line. Verify condensate trap drains freely and clean as required.
- Test safety relief valve for proper operation. Refer to valve manufacturer's instructions packaged with relief valve.
- Examine flue passages in heat exchanger, burner, condensate lines, and cleaning (if necessary) by following instructions in "Annual Examination and Cleaning of Boiler Components" in this section.

**FIGURE 11-1 Sight Glass**

## 11 - GENERAL MAINTENANCE AND CLEANING

- Circulator pump and combustion air blower motor furnished with boiler are permanently lubricated from factory and require no further lubrication. Lubricate field sourced pumps and/or motors according to pump and/or motor manufacturer's instruction.
- Check following components are operating properly and are free of blockages or obstructions:
  - air vent;
  - check venturi air inlet for blockage and clean as required;
  - verify pressure test port cap and combustion test port are in place;
  - return temperature sensor clip must be securely seated on pipe; Check boiler for any sign of leaks.
- Check low water cutoff using user interface (if installed).
  - Check operation by pressing test button on low water cutoff.
    - "Low Water" LED should illuminate and burner should shut down.
    - Should get error message on User Interface (**E36**).
  - Every 5 years remove low water cutoff. Reinstall after cleaning.
  - Every 10 years replace low water cutoff.
- See Table 13 page 42 for flame signal rate at 100% firing rate ( High fire).
- Visual inspection of flame through sight glass. Burner should be fully illuminated. See figure 11-1.
- Check heating system expansion tank.

### 11.2 Annual Shut Down Procedure

- Follow instructions "To Turn Off Gas To Appliance" unless boiler is also used to supply domestic hot water. See section 10.
- Drain system completely if system does not have antifreeze when heating system is to remain out of service during freezing weather.
- Drain condensate lines when boiler is to be exposed to freezing temperatures.

### **WARNING**

Following service procedures must be performed by qualified service agent. Boiler owner shall not attempt these steps. Failure to do so could result in death or serious injury.

### 11.3 Annual Inspection and Cleaning of Boiler Components

Obtain Burner Inspection Kit. Follow heat exchanger cleaning kit instructions for examination and cleaning.

### ! WARNING

Following service procedures must be performed by qualified service agent. Boiler owner shall not attempt these steps. Failure to do so could result in death or serious injury.

### ! WARNING

Combustion chamber insulation in this product contains ceramic fiber material. Ceramic fibers can be converted to cristobalite in very high temperature applications. The International Agency for Research on Cancer (IARC) has concluded, Crystalline silica inhaled in the form of quartz or cristobalite from occupational sources is carcinogenic to humans (Group1). Avoid breathing dust and contact with skin and eyes. Use NIOSH certified dust respirator (N95). This type of respirator is based on the OSHA requirements for cristobalite at the time this document was written. Other types of respirators may be needed depending on the job site conditions. Current NIOSH recommendations can be found on the NIOSH website <http://www.cdc.gov/niosh/homepage.html>. NIOSH approved respirators, manufacturers, and phone numbers are also listed on this website. Wear long-sleeved, loose fitting clothing, gloves, and eye protection. Apply enough water to the combustion chamber lining to prevent dust. Wash potentially contaminated clothes separately from other clothing. Rinse clothes washer thoroughly.

NIOSH stated First Aid. Eye: Irrigate immediately. Breathing: Fresh air.

### ! CAUTION

Label all wires prior to disconnection when servicing controls. Wiring errors can cause improper and dangerous operation. Failure to follow these instructions could result in minor or moderate injury.

### 11.4 Maintenance And Routine Servicing

Check and service boiler as necessary.

Frequency of servicing will depend upon installation conditions and usage, manufacturer recommends annually.

- Check flue termination outside verify it is not blocked.
- Operate boiler and verify operation of its controls and meets acceptable parameters.
- Ensure all system connections and fittings are tight and not leaking. Redo any joints and check the tightness of any fittings that may be leaking.
- Verify safety relief valve is in working order following its manufacturer's instructions.

To ensure boiler is operating at peak efficiency perform the following inspection:

- check appearance and tightness of gas and combustion circuit gaskets
- check condition and position of ignition/flame sensing electrode
- check condition of burner and ensure it's secure to aluminum flange
- check for any dirt in combustion chamber. Use nylon brush with white vinegar and water to clean combustion chamber.
- heat exchanger cleaning kit is available see parts book for details
- check gas valve is calibrated correctly
- check there is no dirt in condensate trap
- check the central heating system pressure
- check on expansion tank pressure
- check vent system and clean it if necessary

Record details and maintain service history.

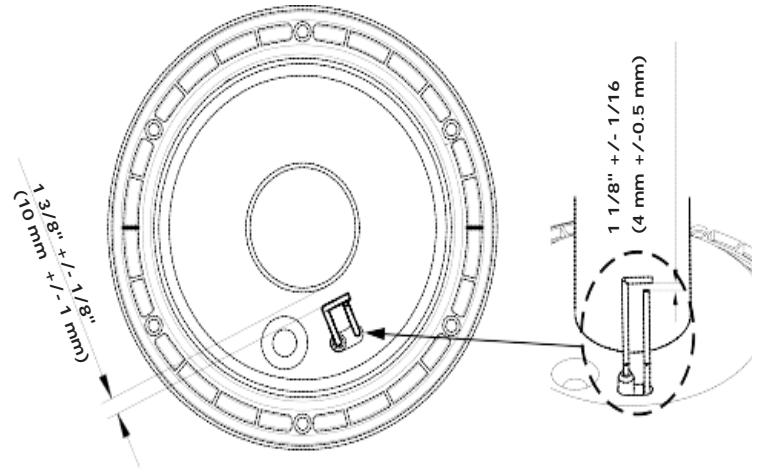
### 11.5 Component Replacement And Cleaning

1. Remove any deposits from heat exchanger using suitable soft brush. *Do not* use brush with metallic bristles.
2. Check condition of the combustion chamber insulation panels. Any damaged panels must be replaced.
3. Check condition of burner injector on the manifold, carefully clean it with a soft brush if necessary. *Do not* use a brush with metallic bristles this might damage the injector.
4. Remove any fallen deposits from bottom of inner case.
5. Clean burner with soft brush and check flame ports are clear. Blockages may be removed with stiffer brush.
6. Check condition of electrodes.
7. Check spark gap, positioning and height of electrodes.
8. Check fan impeller is clean and free to rotate.

**⚠ DANGER**

Before servicing, turn off electrical power to boiler at service switch. Close manual gas valve to turn gas supply OFF to boiler. Failure to comply will result in death or serious injury.

11-1 Electrodes

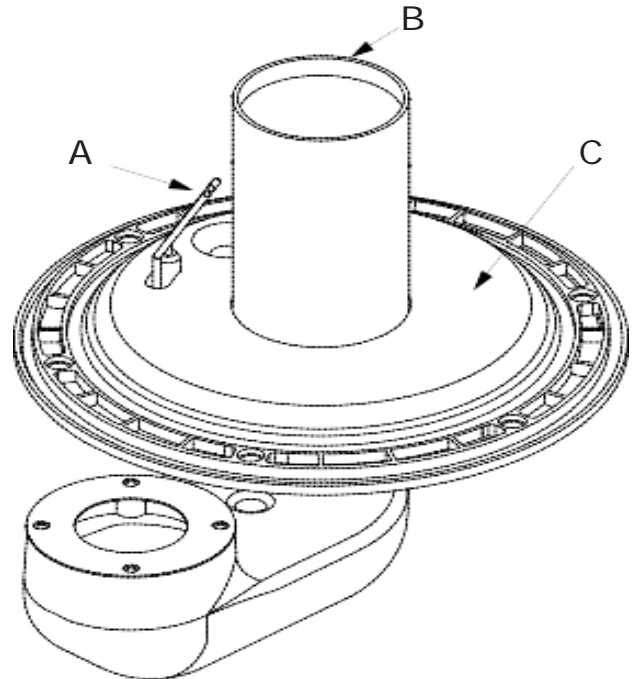


**11.6 Draining the Boiler**

- Turn boiler off
- Isolate electrical supply
- Close boiler gas service cock
- Allow boiler to cool
- Drain boiler through onboard drain (item 19 page 7) or external drain valve.

**Draining the Heating Circuit**

- Follow all steps in 11.6.
- Close central heating flow and return valves.
- Connect suitable pipe to drain point.
- Route it to suitable container.
- Open drain tap.





## 12 - RATINGS AND CAPACITIES



**TABLE 14: SEA LEVEL RATINGS  
NATURAL AND PROPANE GASES**

Model Number	Input, (MBH) <sup>(1)</sup>		Gross Output (MBH) <sup>(1)(2)</sup>	Net AHRI Rating, Water (MBH) <sup>(1)(3)</sup>	Thermal Efficiency
	Maximum	Minimum			
<b>DMG-380</b>	379	35	348	303	95.0

<sup>(1)</sup> 1000 Btu/hr (British Thermal Units Per Hour)

<sup>(2)</sup> Heating Capacity and AFUE (Annual Fuel Utilization Efficiency) are based on DOE (Department of Energy) test procedures.

<sup>(3)</sup> Net AHRI Ratings based on piping and pickup allowance of 1.15. Contact Technical Support before selecting boiler for installations having unusual piping and pickup requirements, such as intermittent system operation, extensive piping systems, etc.

### 12.1 Ratings and Capacities

- Constructed and hydrostatically tested for maximum allowable working pressure of 80 psig (pounds per square inch gauge) (663 kPa) in accordance with ASME Boiler and Pressure Vessel Code, Section IV, Rules for Construction of Heating Boilers.
- In USA**, for elevations beyond 2,000-ft reduce input by 4% for each 1,000-ft above sea level in accordance with National Installation Code ANSI Z223.1

Central Heating		MAX		MIN
		0-2,000 Ft 0-610 m	2,000-4,500 Ft 610-1,370 m	
Heating Input (Gross)	MBH	379	360	35
	kW	111.07	105.56	10.26
Heat Output (modulating)	Btu/h	348,040	330,990	33,100
	kW	102	97	9.7
Gas Rate A (Natural Gas)	ft <sup>3</sup> /h	377.34	360.42	34.8
	m <sup>3</sup> /h	10.69	10.21	0.98
Gas Rate E (LPG Gas)	ft <sup>3</sup> /h	149.16	139.80	13.8
	m <sup>3</sup> /h	4.22	3.96	0.4
Max. CH Water Temp. (Approx.)	°F	176		
	°C	80		

### 13.1 Troubleshooting

This boiler is fitted with an electronic regulation and control unit.

Control system is a microprocessor, Comfort Master®, which controls and protects the boiler. If a fault is detected anywhere in the boiler, boiler will lock out and display will show the fault code as follows:

Red flashing display:

- The  symbol
- The "RESET" symbol

Descriptions of each error code are given in the table below.

To reset an error code, press  button for 2 seconds.

If the error code continues to display, search for the cause in error table and follow instructions given in solution section.

**Note corresponding  
troubleshooting charts for further  
information (CHART xxx)**

**Error Code Table**

Error Code	Description	Probable Causes	Checking/Solution
E00	Storage unit PSU parameter not found	Bad connection	Check the wiring
E01	The safety parameters are incorrect	Bad connection PSU defective	Check the wiring Replace PSU
E02	Supply temperature sensor short circuited	Bad connection Sensor fault Sensor not/poorly connected	Check the wiring Check sensors are operating correctly Check sensor has been correctly fitted Replace sensor if necessary <b>(CHART 1)</b>
E03	Supply temperature sensor open circuit	Bad connection Sensor fault Sensor not/poorly connected	Check the wiring Check sensors are operating correctly Check sensor has been correctly fitted Replace sensor if necessary <b>(CHART 1)</b>
E04	Temperature of heat exchanger too low.	Bad connection Sensor fault Sensor not/poorly connected	Check the wiring Replace sensor if necessary Purge air in heating system Check for water circulation (direction, pump, valves)
E05	Heat exchanger temperature too high	No circulation	Check water pressure Check sensors are operating correctly Check sensors have been correctly fitted Check cleanliness of heat exchanger <b>(CHART 1)</b>
E06	Return temperature sensor short circuited	Bad connection Sensor fault Sensor not /poorly connected	Check the wiring Check sensor has been correctly fitted Check sensors are operating correctly <b>(CHART 1)</b>
E07	Return temperature sensor open circuit	Bad connection Sensor fault Sensor not /poorly connected	Check the wiring Check sensor has been correctly fitted Check sensors are operating correctly <b>(CHART 1)</b>
E08 E09	Return temperature too low Return temperature too high	Bad connection Sensor fault Sensor not/poorly connected No circulation	Check the wiring Replace sensor if necessary Purge air from heating system Check for water circulation (direction, pump, valves) Check water pressure Check sensors are operating correctly Check sensors have been correctly fitted Check cleanliness of heat exchanger <b>(CHART 1)</b>

## 13 - TROUBLE SHOOTING

### Error Code Table


Error Code	Description	Probable Causes	Checking/Solution
E10 E11	Temperature difference between the supply and return temperatures too great	Sensor fault Sensor not/poorly connected No circulation	Replace the sensor if necessary Purge the air in the heating system Check for water circulation (direction, pump, valves) Check that the sensors are operating correctly Check the cleanliness of the heat exchanger Check that the heating pump is operating correctly <b>(CHART 4)</b>
E12	Temperature of heat exchanger is above the normal range (high-limit thermostat Safety Thermostat)	Bad connection Sensor fault Sensor not/poorly connected No circulation	Check the wiring Replace the sensor if necessary Purge the air in the heating system Check for water circulation (direction, pump, valves) Check that the sensors are operating correctly Check the cleanliness of the heat exchanger Check that parameter P35 has been set correctly <b>(CHART 3)</b>
E14	5 burner start-up failures	No ignition	Check spark generator wiring Check the ionization/ignition electrode Check the condition of the burner Check the grounding Defective control SU PCB <b>(CHART 5)</b>
		Presence of spark but no flame formation	Purge the gas supply to remove air Check that the gas valve is fully opened Check the gas supply pressure Check the operation and setting of the gas valve Check that the air inlet and exhaust flue are not blocked Check the wiring on the gas valve Defective control SU PCB <b>(CHART 5)</b>
		Presence of the flame but insufficient ionization (<3 µA)	Check that the gas valve is fully opened Check the supply pressure Check the ionization/ignition electrode Check the grounding Check the wiring on the ionization/ignition electrode <b>(CHART 5)</b>
E16	False flame signal	Ionization current present when there should not be a flame Ignition transformer defective Gas valve defective The burner remains very hot: CO too high	Check the ionization/ignition electrode Check the gas valve and replace if necessary Recalibrate the CO <sub>2</sub> <b>(CHART 2)</b>
E17	Problem on SU PCB	Bad connection Defective SU PCB	Check the wiring Inspect the SU PCB and replace it if need be
E34	Fan fault	Bad connection Fan defective	Check the wiring Replace Fan if necessary Check for adequate draw on the flue connection <b>(CHART 7)</b>
E35	Supply and return reversed	Bad connection Sensor fault Sensor not/poorly connected Water circulation direction reversed	Replace the sensor if necessary Check for water circulation (direction, pump, valves) Check that the sensors are operating correctly Check that the sensors have been correctly fitted <b>(CHART 4)</b>
E36	Flame loss	No ionization current	Purge the gas supply to remove air Check that the gas valve is fully opened Check the supply pressure Check the operation and setting of the gas valve Check that the air inlet and exhaust flue are not blocked Check that there is no recirculation of flue gases <b>(CHART 6)</b>

**Error Code Table**

Error Code	Description	Probable Causes	Checking/Solution
E37	Communication error with SU PCB	Bad connection	Check whether the SU PCB has been correctly fitted in connector on PCU PCB
E38	Communication error with SCU PCB	Bad connection Defective SCU PCB	Check the wiring Replace SCU PCB
E39	Shutdown input in locked-out mode	Bad connection External problem Parameter incorrectly set	Check the wiring Find external problem Check the parameters <b>(CHART 8)</b>
E40	HRU unit test error	Bad connection External problem Parameter incorrectly set	Check the wiring Find the external problem Check the parameters <b>(CHART 9)</b>
E41	No water temperature change during deaeration/air purge	Bad connection Supply/Return sensor damaged No water circulation	Check the sensor connection Replace sensor Check the pump connection
E42	Low water cutoff disconnected or water pressure too low	Bad connection Water pressure low	Check the wiring Refill the system Check for leaks <b>(CHART 10)</b>
E43	No water temperature change during boiler operation (burner on)	Bad connection Supply/Return sensor damaged No water circulation	Check the sensor connection Replace the sensor Check the pump connection <b>(CHART 11)</b>
E44	Difference between supply/return temperature too high	Bad connection Supply/Return sensor damaged No water circulation	Check sensor connection Replace sensor Check pump connection

### 13.2 Shutdowns and Lock-outs



#### Blockage

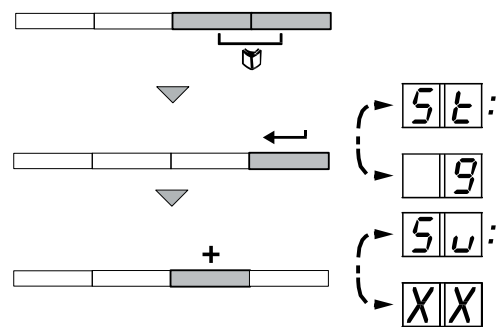
If a blockage condition continues to exist after several start up attempts, boiler will switch into lock-out (fault) mode. The boiler can only start operating again once cause(s) of the lock-out have been rectified and after pressing  button.

#### Lock-out Mode

A temporary lock-out caused by an unusual occurrence in the boiler's operation. E.g. Display gives code of blocked flue (code St9). Boiler control will try to re-start several times. Boiler will start up again after blocking condition(s) have been eliminated.

Shutdown codes can be read out as follows:

- Press the two buttons  simultaneously.
- Confirm by pressing  button. "St" is displayed, alternating with the shutdown code "9".
- Press the (+) button. "Su" appears on the screen.



Boiler will start again automatically when reason for blocking has been removed.

## 13 - TROUBLE SHOOTING

### Shutdown Code Table

Shut-down Code	Description	Probable Causes	Checking/Solution
Su:0	Parameter error	Parameter error on the PSU PCB	Reset df and dU Restore parameters
Su:1	Maximum supply temperature exceeded	Non-existent or insufficient circulation / sensor error	Check the circulation (direction, pump, valves) Reasons for the heat demand
Su:2	Maximum increase of the supply temperature has been exceeded	Non-existent or insufficient water circulation / sensor error	Check the circulation (direction, pump, valves) Check the water pressure Check sensors are operating correctly Check sensor has been correctly fitted Check cleanliness of heat exchanger
Su:7	Max difference between T. supply/return exceeded	Non-existent or insufficient circulation / sensor error	Check the circulation (direction, pump, valves) Check the water pressure Check the sensors are operating correctly Check that the sensor has been correctly fitted Check the cleanliness of the heat exchanger
Su:8	No release signal	External cause Parameter error Bad connection	Correct the external cause Check the parameters Check the wiring
Su:9	Line and neutral of power supply are mixed up (if P43=1)	Power supply incorrectly wired Floating or 2 phase network	Line and neutral mixed up Set parameter p43 to 0
Su:10	Shutdown input is open	External cause Parameter error Bad connection	Correct the external cause Check the parameters Check the wiring
Su:11	Shutdown input active or frost protection active	External cause Parameter error Bad connection	Correct the external cause Check the parameters Check the wiring
Su:13	Communication error with the SCU PCB	Bad connection with BUS SCU PCB not installed in boiler	Check the wiring Carry out automatic detection to find aux. PCB's
Su:15	Gas pressure too low	Non-existent or insufficient gas Pressure. Incorrect setting of the Gps gas pressure switch on SCU PCB	Check that the gas valve is fully opened Check the supply pressure Check whether the Gps gas pressure control system has been correctly fitted Replace the Gps gas pressure control system if need be
Su:16 <sup>(1)</sup>	Configuration fault or SU PCB not recognized	Wrong SU PCB for this boiler	Replace the SU PCB
Su:17 <sup>(1)</sup>	Configuration fault or default parameter table incorrect	Parameter dF-dU error on the PSU PCB	Reset df and dU Restore parameters
Su:18 <sup>(1)</sup>	Configuration fault or PSU PCB not recognized	Wrong PSU PCB for this boiler	Replace the PSU PCB
Su:19 <sup>(1)</sup>	Configuration fault or parameters "df-du" unknown	---	Reset df and dU Restore parameters

## 13 - TROUBLE SHOOTING

### Shutdown Code Table

Shut-down Code	Description	Probable Causes	Checking/Solution
Su: 20 <sup>(1)</sup>	Identification running	---	No action required
Su: 21	Communication error with SU PCB	Bad connection	Check whether SU PCB has been correctly fitted in the connector on SU PCB
Su: 22	No flame during operation	No ionization current	Purge gas supply to remove air Check gas valve is fully opened Check supply pressure Check operation and setting of gas valve Check air inlet and exhaust are not blocked Check there is no recirculation of combustion gases
Su: 25 <sup>(1)</sup>	Internal error on the SU-PCb	---	Replace the SU PCB
Su: 29 <sup>(2)</sup>	tFG sensor above maximum setpoint	Non-existent or insufficient water circulation / sensor error	Replace flue high limit. Check circulation (direction, pump, valves) Check water pressure Check sensors are operating correctly Check sensor has been correctly fitted Check cleanliness of heat exchanger
Su: 30 <sup>(2)</sup>	No tFG sensor connected /shorted Boiler stop	Flue high limit disconnected / Sensor error	Replace flue high limit.
Su: 33	After 5 times tF>tF Max: controlled stop	Non-existent or insufficient circulation / sensor error	Replace supply sensor. Check circulation (direction, pump, valves) Check water pressure Check sensors are operating correctly Check sensor has been correctly fitted Check cleanliness of heat exchanger
Su: 34 <sup>(2)</sup>	After 5 times tFG>tFmax: controlled stop	Non-existent or insufficient circulation / sensor error	Replace flue high limit. Check circulation (direction, pump, valves) Check water pressure Check sensors are operating correctly Check sensor has been correctly fitted Check cleanliness of heat exchanger
Su: 35	Insufficient gradient on T1(supply) or T2(return) after burner starts	Non-existent or insufficient circulation / sensor error	Check circulation (direction, pump, valves) Check water pressure Check sensors are operating correctly Check sensor has been correctly fitted Check cleanliness of heat exchanger

<sup>(1)</sup> These lock-outs are not stored in fault memory

<sup>(2)</sup> tFG : flue gas sensor







### 13.3 Error History

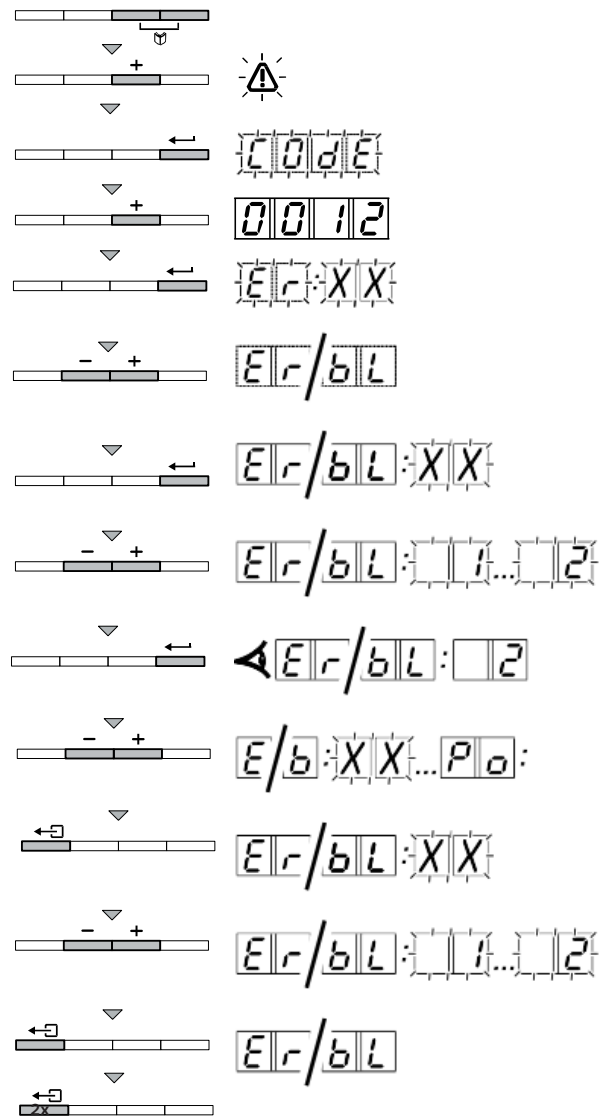
Boiler control is equipped with error memory which, records last 16 errors. In addition to storing error codes, the following data is also saved:




- Number of times that the error occurred: (**n:xx**).
- Boiler operating mode selected (**St:xx**).
- The supply temperature (**t1:xx**) and the return temperature (**t2:xx**) when the error occurred.

To view the error history, enter access code **0012**.

### 13.4 Error History Readout

- Press two  buttons simultaneously and then (+) button until the  symbol flashes on the menu bar.
- Select the installers menu using  button. "CODE" appears on the display.
- Use (-) or (+) button to input installer code **0012**.
- Press  button. "Er:xx" appears on the display.
- The fault list can be displayed by pressing (-) or (+) button.
- Confirm using  button. "Er:xx" is displayed with "xx" flashing = Last error which occurred, for example "2".
- Use (-) or (+) buttons to scroll through faults.
- Press  button to display details of faults or shutdowns.
- Press (-) or (+) buttons to view the following information:  
**n:1** = Number of times that the error occurred.  
**hr** = The number of operating hours.  
**St** = State.  
**Su** = Sub-status.  
**t1** = Supply temperature °F/°C.  
**t2** = Return temperature °F/°C. t3 = DHW tank temperature °F/°C.  
**t4** = Outdoor temperature °F/°C (Only with an outdoor temperature sensor).  
**t5** = Solar panel temperature °F/°C. t6 = Flue gas temperature °F/°C.  
**Sp** = Internal set point °F/°C.  
**fl** = Ionization current (µA).  
**nf** = Fan speed in rpm.  
**Pr** = Water pressure psi/bar.  
**Po** = Supplied relative heat output (%).



- Press  button to interrupt display cycle. "Er:xx" is displayed with "xx" flashing = Last error which occurred.
- Use (-) or (+) button to scroll through faults.
- Press  button to show fault list.
- Press  button 2 times to exit error history.

13.5 Optional Sensors

1. 1 K  $\Omega$  Outdoor Air Sensor, if used.
  - A. Boiler automatically recognizes sensor when used.
  - B. See Chart 1 for sensor data. Sensor part number BD710487302V
  - C. Locate outdoor sensor to protect against wind and direct sunlight. Mounting instructions provided with sensor.
  - D. Maximum wire length is 100 ft (30m) for 22 ga. wire, or 150 ft (45m) for 18 ga. wire.
  
2. 10 K  $\Omega$  Sensor for Indirect DHW Tank (Heating Only Boiler).
  - A. See Chart 2 for sensor data.

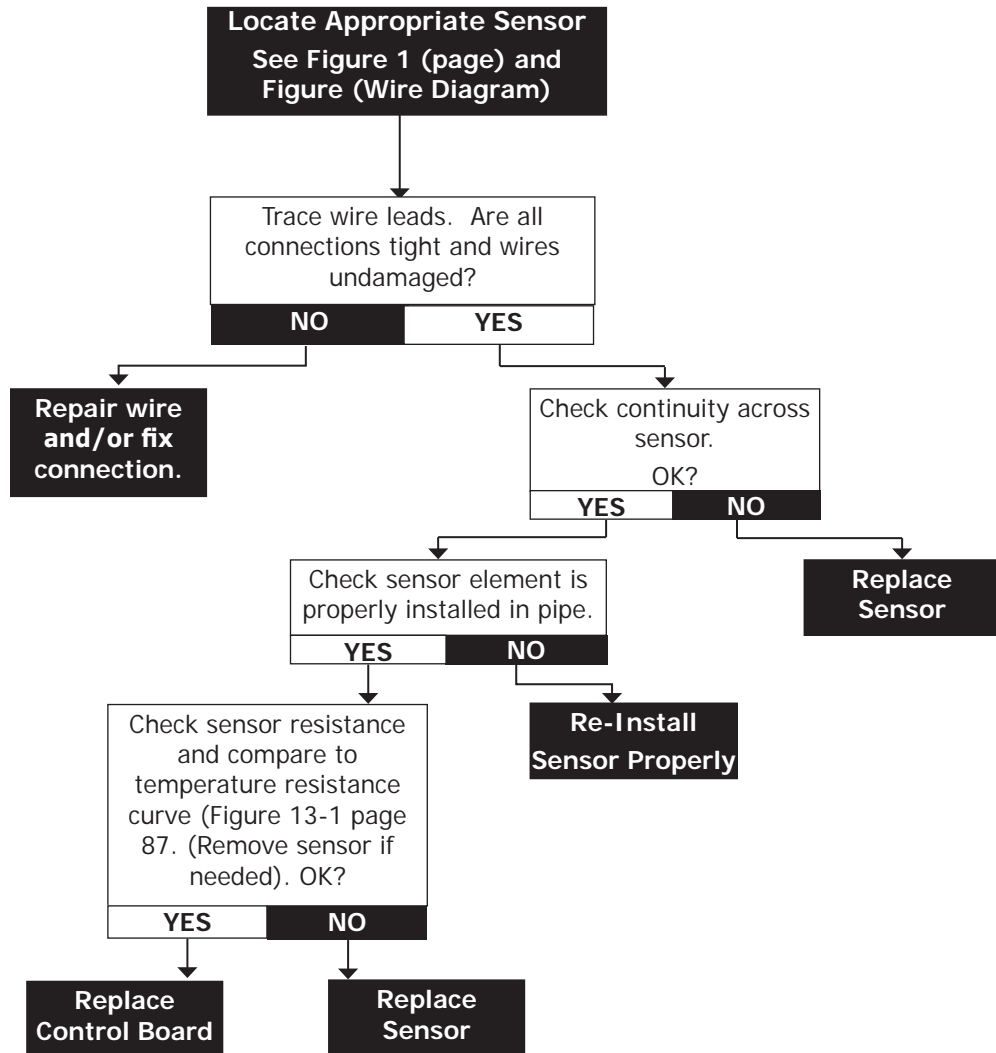
T [°F]	R [Ohm]	T [°F]	R [Ohm]
-4.0	7,578	53.6	1,690
-2.2	7,193	55.4	1,621
-0.4	6,831	57.2	1,555
1.4	6,489	59.0	1,492
3.2	6,166	60.8	1,433
5.0	5,861	62.6	1,375
6.8	5,574	64.4	1,321
8.6	5,303	66.2	1,268
10.4	5,046	68.0	1,218
12.2	4,804	69.8	1,170
14.0	4,574	71.6	1,125
15.8	4,358	73.4	1,081
17.6	4,152	75.2	1,040
19.4	3,958	77.0	1,000
21.2	3,774	78.8	962
23.0	3,600	80.6	926
24.8	3,435	82.4	892
26.6	3,279	84.2	858
28.4	3,131	86.0	827
30.2	2,990	87.8	796
32.0	2,857	89.6	767
33.8	2,730	91.4	740
35.6	2,610	93.2	713
37.4	2,496	95.0	687
39.2	2,387	96.8	663
41.0	2,284	98.6	640
42.8	2,186	100.4	617
44.6	2,093	102.2	595
46.4	2,004	100.4	617
48.2	1,920	102.2	595
50.0	1,840	104.0	575
51.8	1,763	106.0	556

T [°F]	R [Ohm]	T [°F]	R [Ohm]
32.0	32,505	86.0	8,060
33.8	30,898	87.8	7,726
35.6	29,381	89.6	7,407
37.4	27,946	91.4	7,103
39.2	26,590	93.2	6,813
41.0	25,308	95.0	6,537
42.8	24,094	96.8	6,273
44.6	22,946	98.6	6,021
46.4	21,859	100.4	5,781
48.2	20,829	102.2	5,551
50.0	19,854	104.0	5,332
51.8	18,930	105.8	5,123
53.6	18,054	107.6	4,923
55.4	17,223	109.4	4,732
57.2	16,436	111.2	4,549
59.0	15,689	113.0	4,374
60.8	14,980	114.8	4,207
62.6	14,306	116.6	4,047
64.4	13,667	118.4	3,894
66.2	13,060	120.2	3,748
68.0	12,483	122.0	3,608
69.8	11,935	123.8	3,473
71.6	11,414	125.6	3,345
73.4	10,919	127.4	3,222
75.2	10,447	129.2	3,104
77.0	9,999	131.0	2,991
78.8	9,572	132.8	2,882
80.6	9,166	134.6	2,778
82.4	8,779	136.4	2,679
84.2	8,411	138.2	2,583



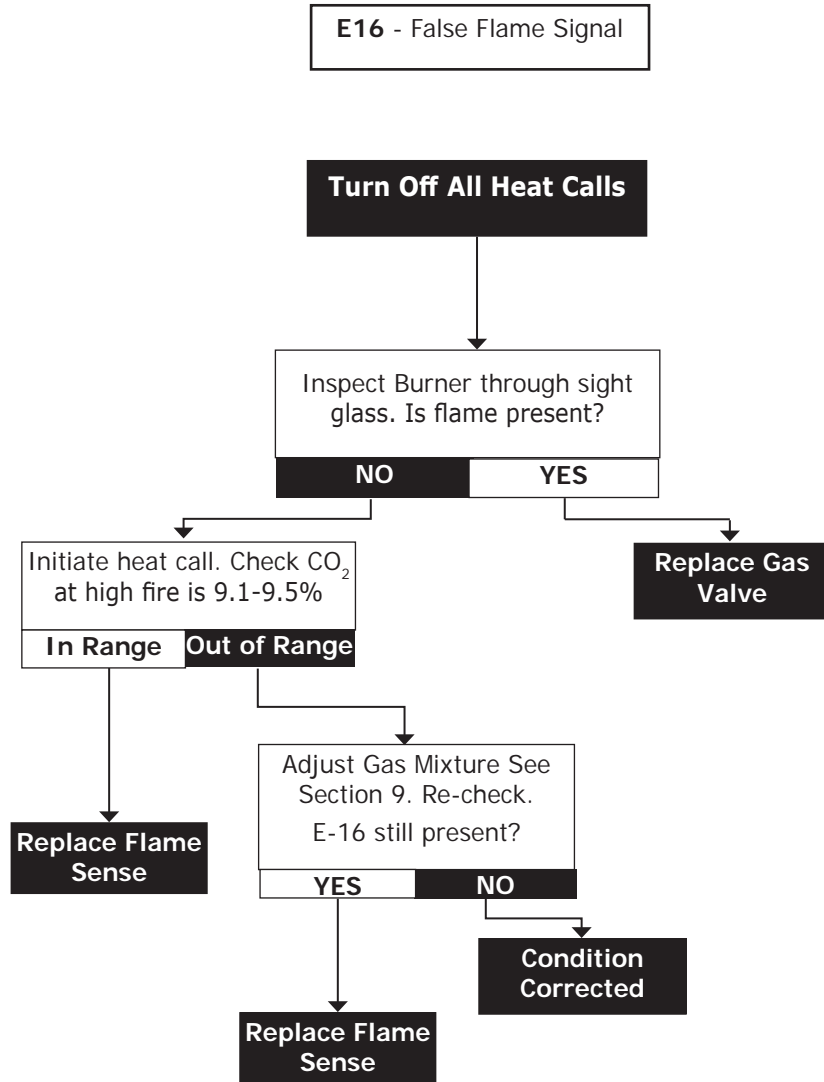
**Troubleshooting Chart 1**

- E02 - Supply Sensor Short
- E03 - Supply Sensor Open
- E04 - Heat Exchanger Temp.
- E05 - Heat Exchanger Temp.
- E06 - Return Sensor Short
- E07 - Return Sensor Open
- E08 - Low Return Temp.
- E09 -High Return Temp.

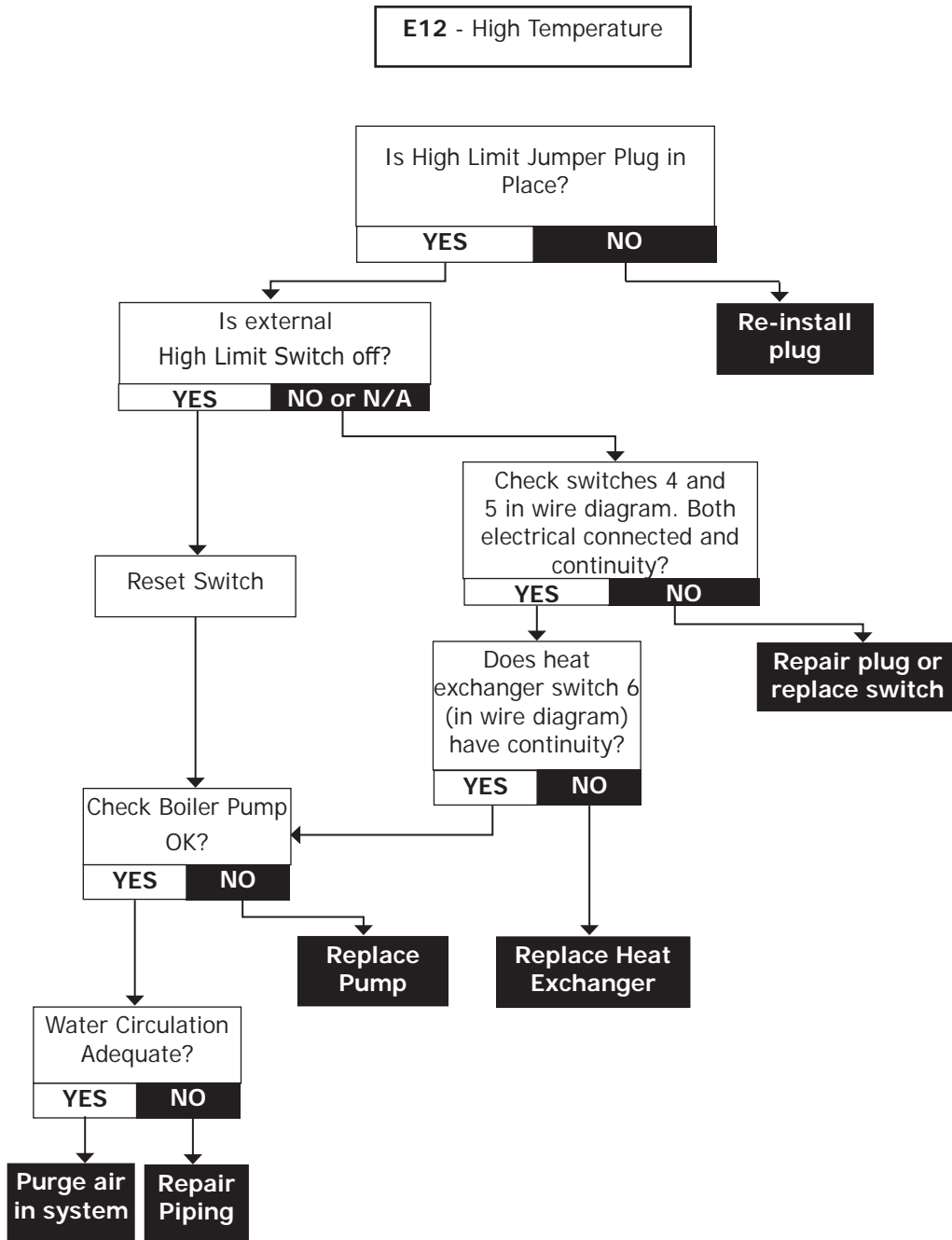


**DOMESTIC HOT WATER SENSOR:** If the DHW sensor is shorted it will act as a closed thermostat and boiler will continuously fire.

**Troubleshooting Chart 2**

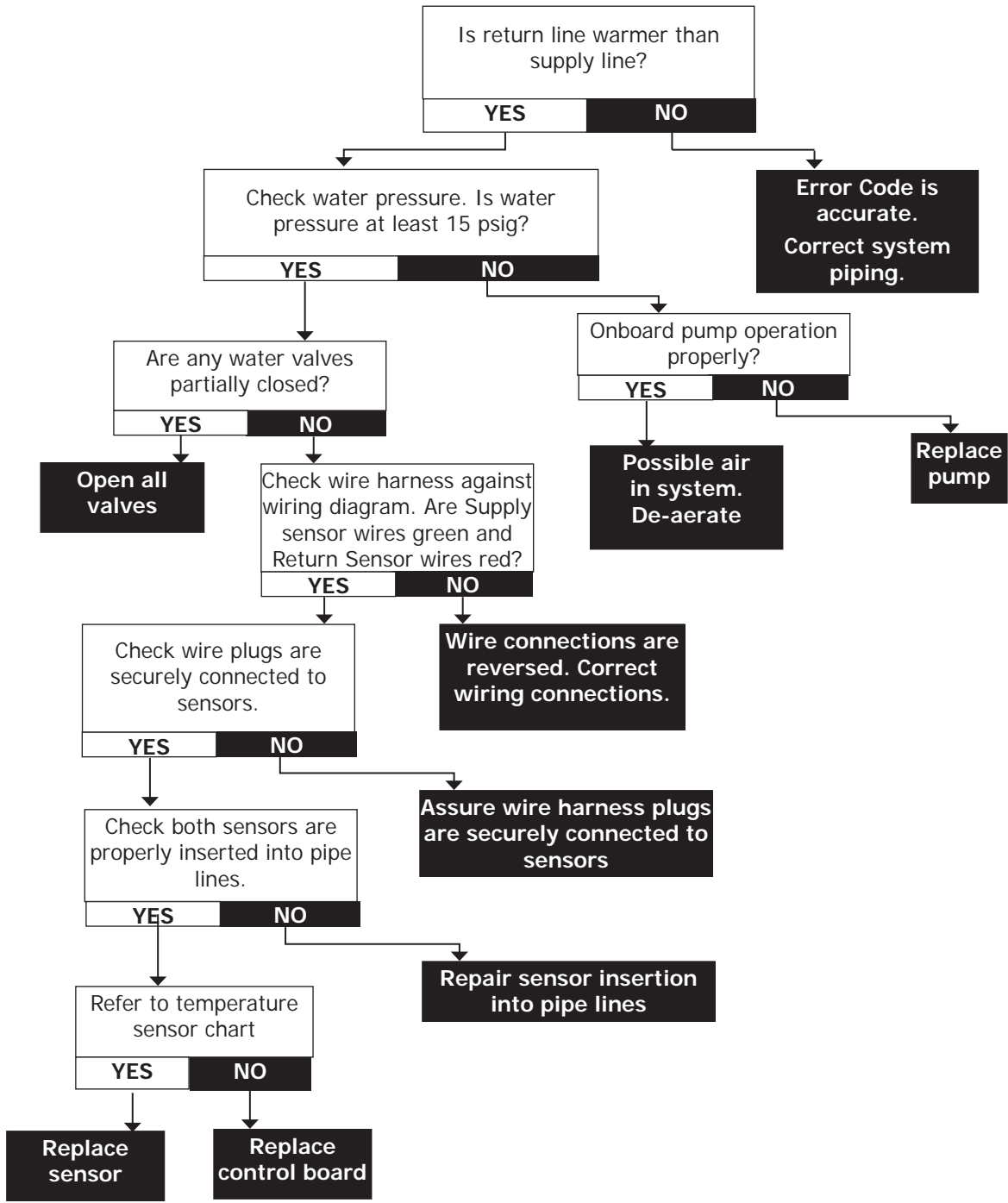


**Troubleshooting Chart 3**

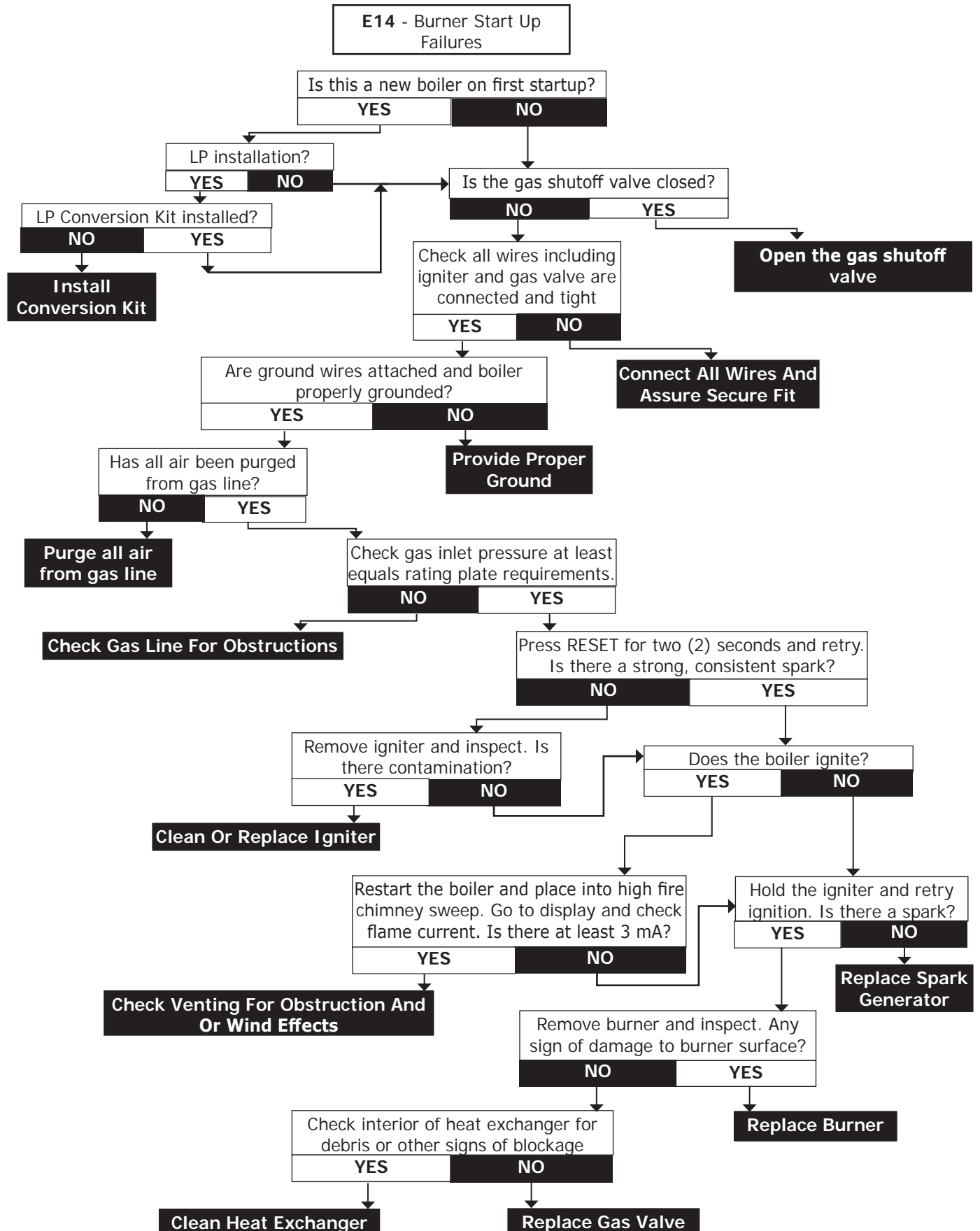


**Troubleshooting Chart 4**

**E10, E11 - Temperature Difference Between Supply and Return Too Great**  
**E35 - Supply and Return Sensors Reversed**

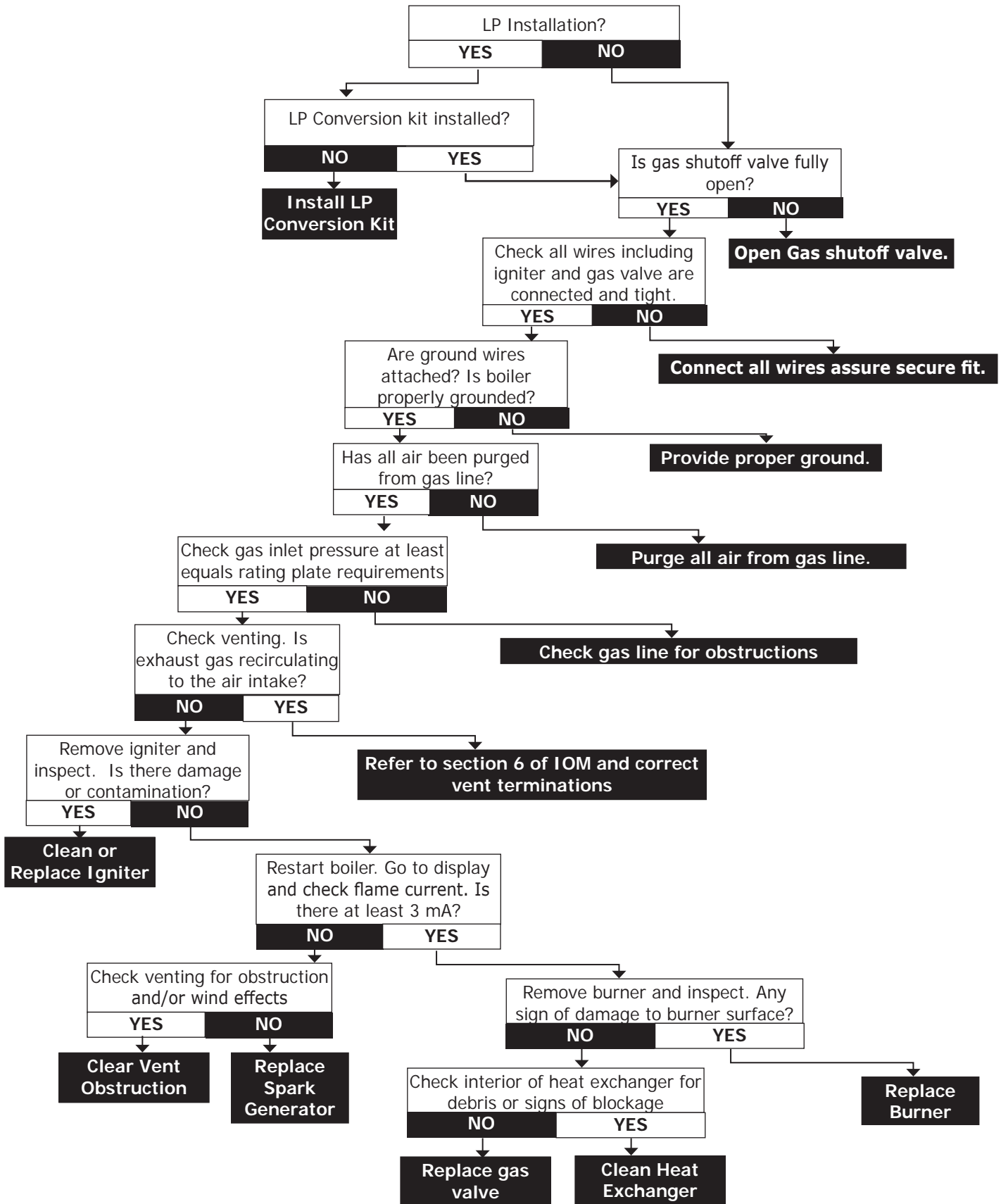


**Troubleshooting Chart 5**

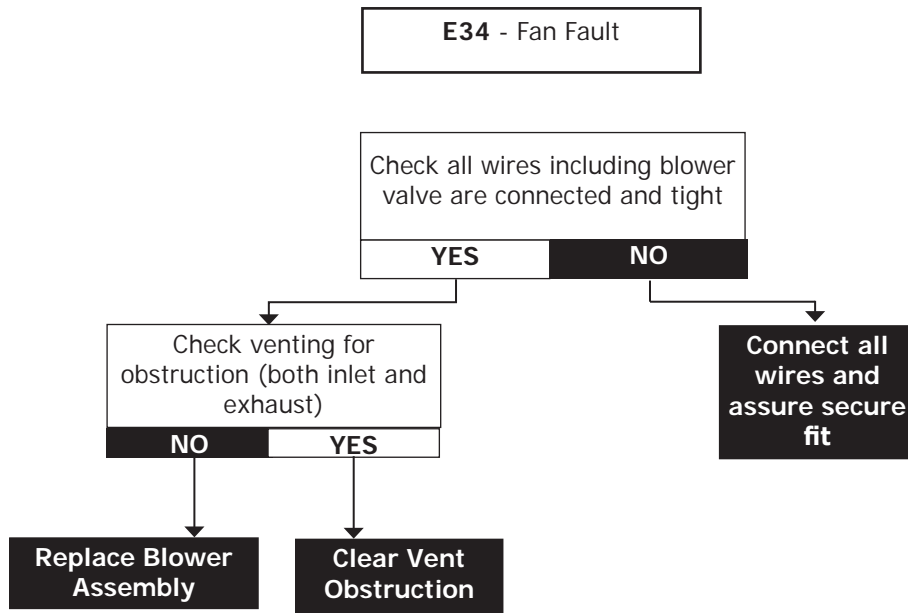


**Troubleshooting Chart 6**

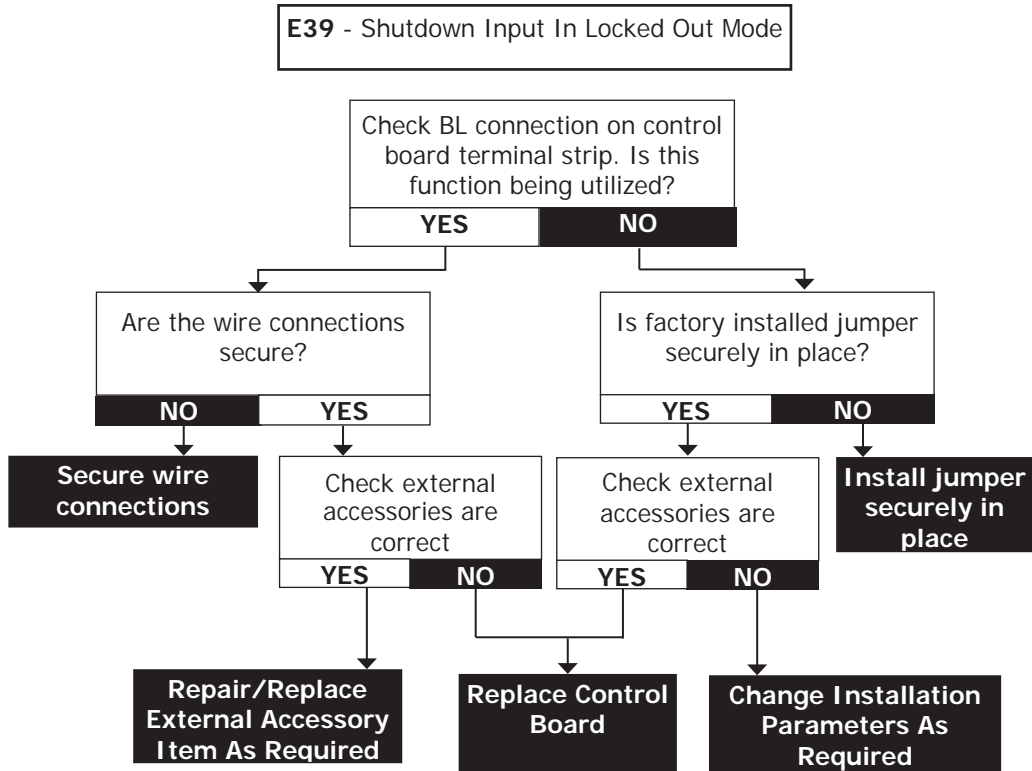
**E36 - Burner Flame Loss**



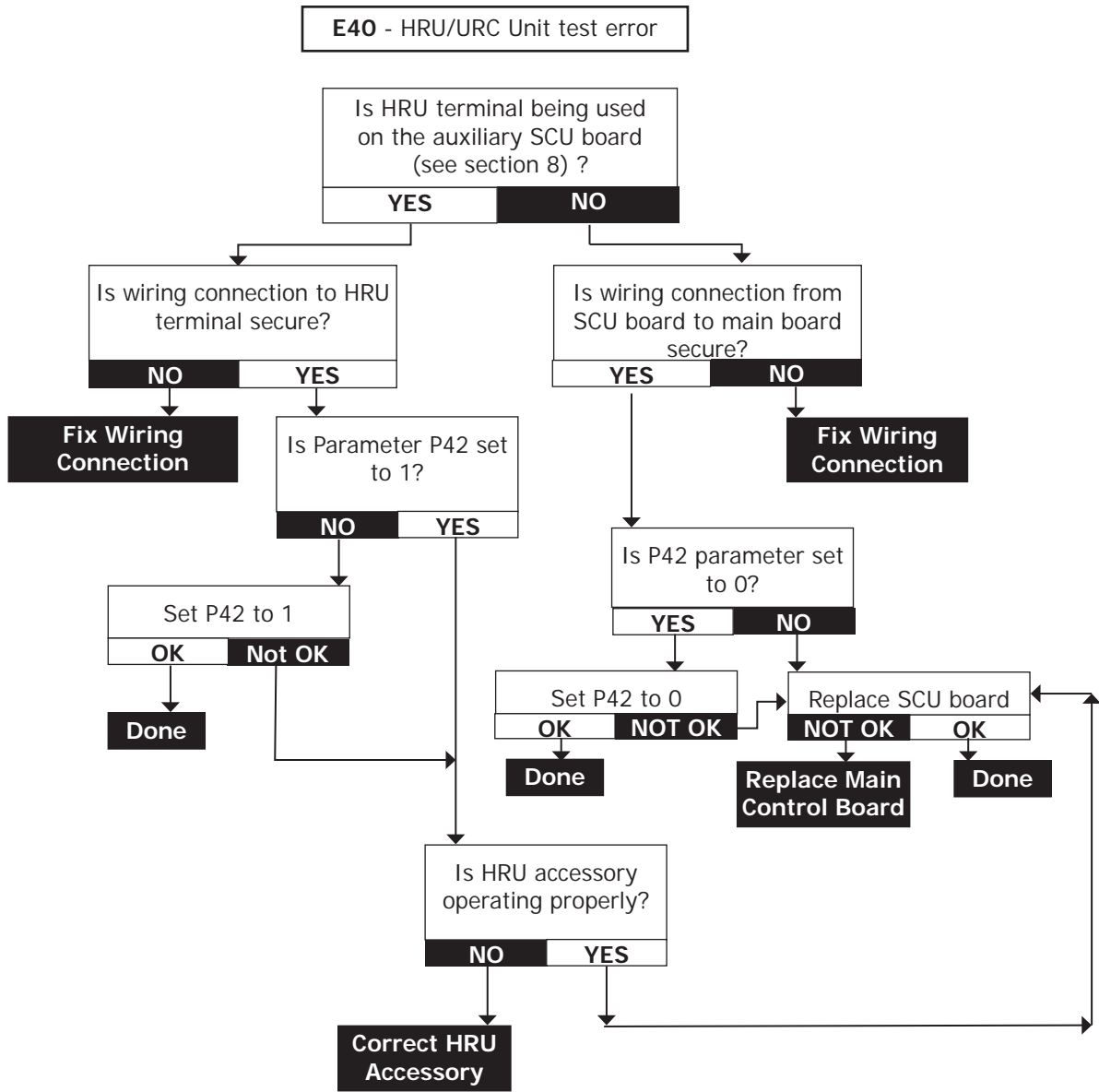
**Troubleshooting Chart 7**



**Troubleshooting Chart 8**



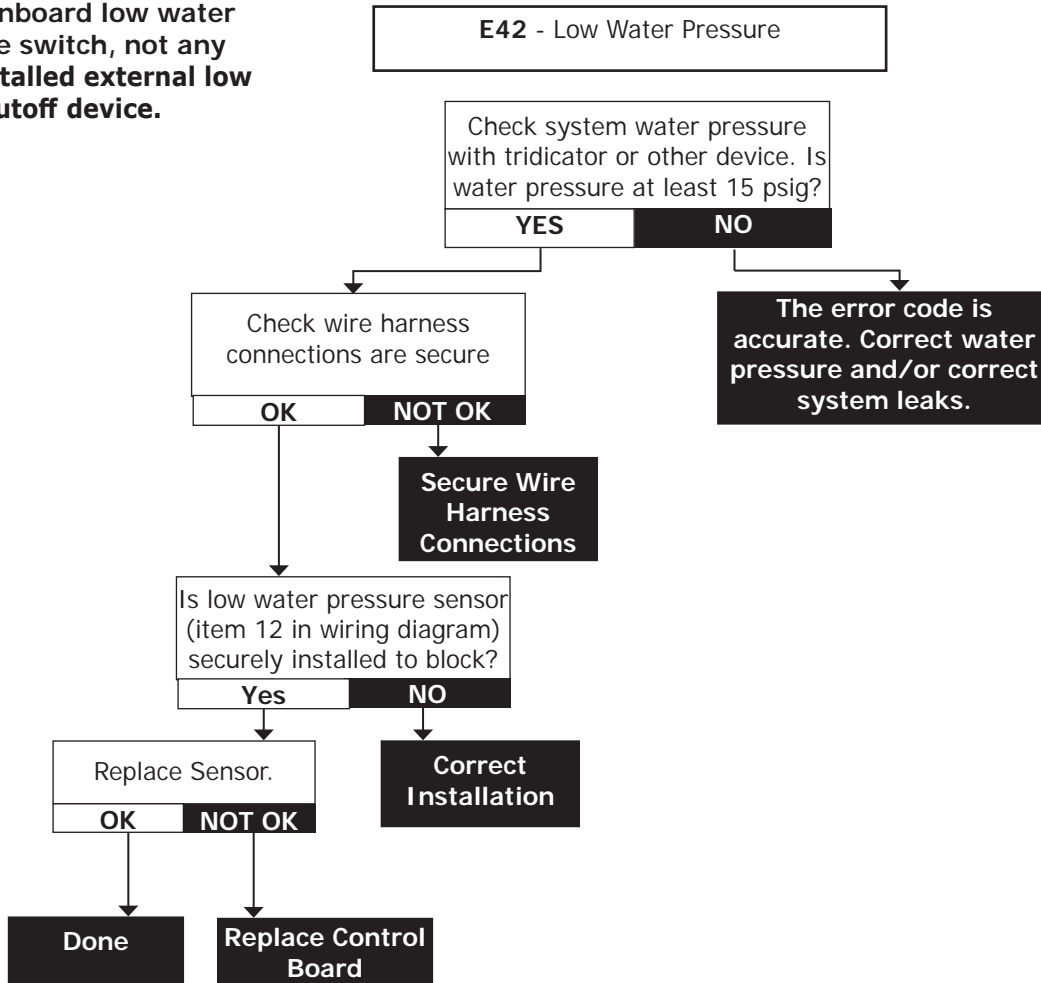
**Troubleshooting Chart 9**



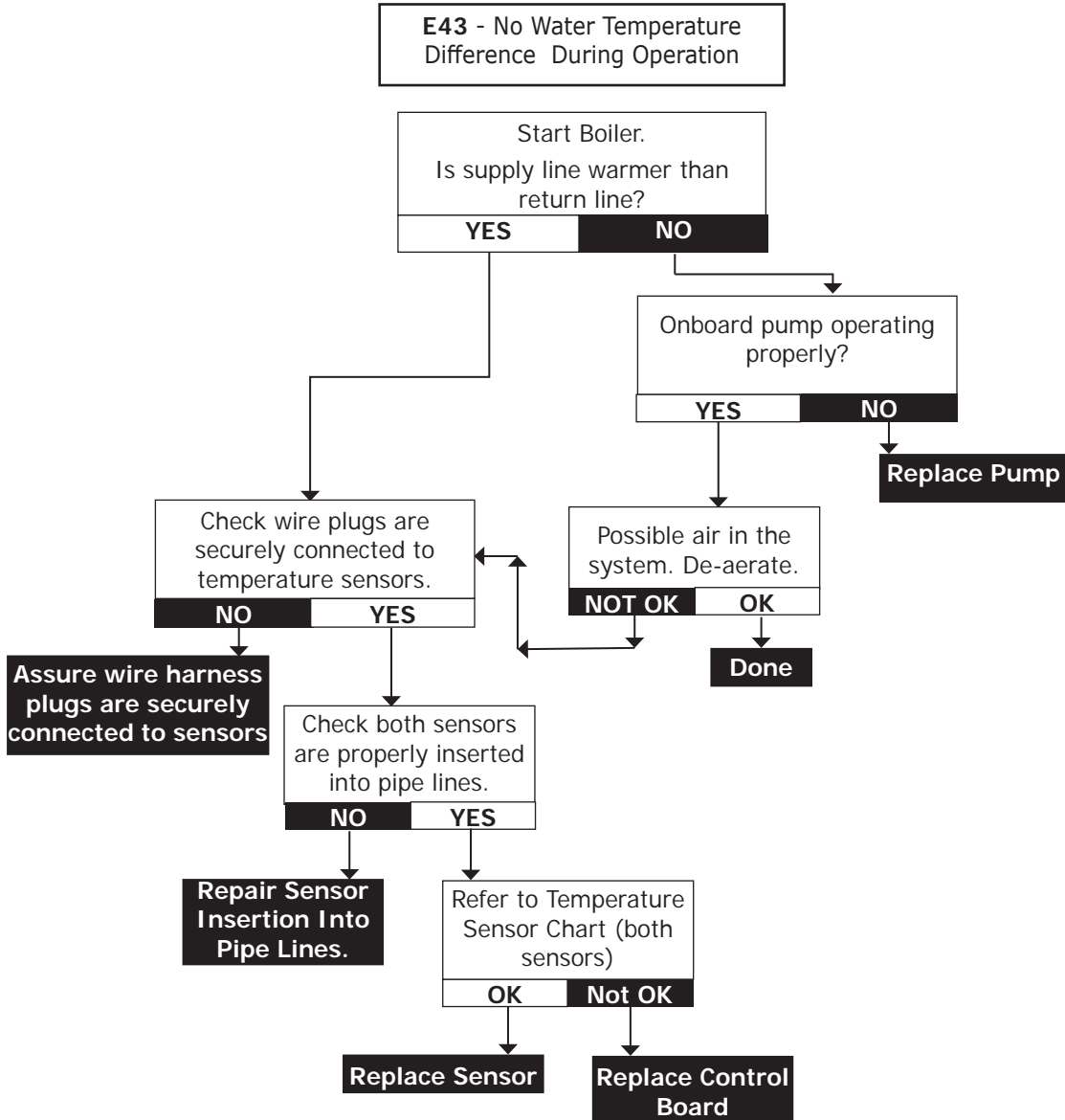


**Troubleshooting Chart 10**

**Note:** This error code refers to the onboard low water pressure switch, not any field installed external low water cutoff device.



Troubleshooting Chart 11



**Figure 13-1 Temperature-Resistance Chart for  
Supply and Return Temperature Sensors**

T (°C)	T (°F)	R (Ohm)
-40	-40	309396
-30	-22	171840
-20	-4	98932
-10	14	58879
0	32	36129
10	50	22804
20	68	14773
25	77	12000
30	86	9804
40	104	6652
50	122	4607
60	140	3252
70	158	2337
80	176	1707
90	194	1266
100	212	952
110	230	726
120	248	560
130	266	438
140	284	345
150	302	275

## 14 - GLOSSARY

- **APPLIANCE** - Device to convert gas into energy; term includes any component, control, wiring, piping or tubing required to be part of the device.
  - **ANSI** - American National Standards Institute, Inc. Oversees creation and maintenance of voluntary consensus standards, including ANSI Z21.13/CSA 4.9: Gas-Fired Low Pressure Steam and Hot Water Boilers.
  - **ASTM** - American Society for Testing and Materials. ASTM International is one of largest voluntary standards development organizations in world trusted source for technical standards for materials, products, systems, and services. Known for their high technical quality and market relevancy, ASTM International standards have important role in information infrastructure that guides design, manufacturing and trade in the global economy.
  - **AUTHORITY HAVING JURISDICTION** - Individual or organization adopting and enforcing codes, rules, and by-laws governing various concerns of community. Commonly referred to as "final authority" for any matters relating to LIFE SAFETY and BUILDING CONSTRUCTION within a community.
  - **BOILER** - Appliance intended to supply hot liquid for space-heating, processing or power purposes.
  - **Btu** - Abbreviation for British Thermal Unit. Quantity of heat required to raise temperature of 1 pound of water 1°F.
  - **BURNER** - Device for final conveyance of gas or mixture of gas and air, to combustion zone.
  - **CALIBRATE** - Make fine adjustments or divide into marked intervals for optimal measuring.
  - **COMBUSTION** - Rapid oxidation of fuel gases accompanied by production of heat or heat and light. Complete combustion of fuel is possible only in presence of adequate supply of Oxygen.
  - **COMBUSTIBLE MATERIAL** - Materials made of or surfaced with wood, compressed paper, plant fibers, or other materials capable of being ignited and burned. Such material shall be considered combustible even though flame-proofed, fire-retardant treated, or plastered.
  - **COMBUSTION AIR** - Air that is drawn into an appliance to mix with fuel and support combustion.
  - **CONDENSATE** - Liquid separated from flue gas due to reduction in temperature.
  - **DIRECT VENT BOILER** - Boiler constructed and installed so all combustion air is derived directly from outdoors and all vent gases are discharged to outdoors.
  - **DOMESTIC** - Relating to household usage as opposed to commercial usage.
  - **DOMESTIC WATER** - Potable drinking water - tap water.
  - **DRAFT** - Pressure difference causes gases or air to flow through a chimney, vent, flue or appliance.
  - **FLA** - Full load amps.
  - **FLUE** - Enclosed passageway for conveying combustion gases.
  - **FLUE GASES** - Products of combustion plus excess air in appliance flues or heat exchanger.
  - **GAS SUPPLIER** - Party that sells commodity of Natural Gas (Gas A) or LPG (Gas E).
  - **HIGH-VOLTAGE** - Circuit involving potential of not more than 600 volts and having circuit characteristics in excess of those of low-voltage circuit.
  - **IGNITER** - Device utilizing electrical energy to ignite gas at main burner.
  - **LEAK CHECK** - Operation performed on gas piping system to verify system does not leak.
  - **LICENSED QUALIFIED INSTALLER / SERVICE TECHNICIAN** - any individual, firm, corporation or company that either directly or through a representative is engaged in the installation, replacement, repair or servicing of gas piping, venting systems, appliances, components, accessories, or equipment, and whose representative is experienced and trained, in such work and has complied with the requirements of the authority having jurisdiction.
  - **LOW WATER CUTOFF** - Device constructed to automatically cut off fuel supply when surface of water in boiler falls to lowest safe water level.
  - **LOW-VOLTAGE** - Circuit involving potential of not more than 30 volts.
  - **METRIC GAS METERS**
    - Natural Gas**
$$\text{MBH} = \frac{127,116 \times \text{cu meters}}{\text{Seconds}}$$
- For example: Gas Meter measures 0.1 cubic Meters in 100 seconds
- $$\text{MBH} = \frac{127,116 \times 0.1}{100} = 127 \text{ MBH}$$
- Propane Gas (LP)**
$$\text{MBH} = \frac{383,482 \times \text{cu meters}}{\text{Seconds}}$$

- **PRESSURE TEST** - Operation performed to verify gas tight integrity of gas piping following its installation or modification.
- **PURGE** - To free gas conduit of air or gas, or mixture of gas and air.
- **PURGE TIME** - Period of time intended to allow for dissipation of any unburned gas or residual products of combustion.
- **QUALIFIED AGENCY** - Any individual, firm, corporation, or company engaged in and responsible for:
  - Installation, testing, or replacement of gas piping, or connection, installation, testing, repair or servicing of appliances and equipment.
  - Experienced in such work.
  - Familiar with all precautions required.
  - Complies with all requirements of authority having jurisdiction.
- **SAFETY RELIEF VALVE** - Valve designed to relieve pressure in hot water supply system when pressure exceeds pressure capability of equipment.
- **SAFETY SHUTOFF DEVICE** - Device that will shut off gas supply to controlled burner in event source of ignition fails.
- **SEDIMENT TRAP** - Gas piping arrangement designed to collect any liquid or solid contaminant before reaching gas valve.
- **SERVICE** -Supply, installation, or maintenance of goods carried out by a Qualified Installer / Service Technician.
- **TWO PIPE SYSTEM** - Type of venting that allows for exhaust flue and intake air piping to be separated from each other. Fresh air may be drawn in at a different area from where flue terminal is located.
- **VENT** - Passageway used to convey flue gases from appliance vent connector to outdoors.
- **VENTING SYSTEM** - Continuous open passageway from of appliance vent connector to outdoors for purpose of removing flue or vent gases.



**INSTALLATION AND CHECK-OUT CERTIFICATE**

**Boiler Model** \_\_\_\_\_ **Serial #** \_\_\_\_\_ **Date Installed** \_\_\_\_\_

**Measured BTU/HR input** \_\_\_\_\_

- Installation instructions have been followed**
- Checkout procedure and adjustments performed**
- Maintenance and Service issues reviewed with owner/ maintenance person**
- Installation booklet affixed on or adjacent to boiler**

**Installer (Company)** \_\_\_\_\_

**Address** \_\_\_\_\_

**Phone** \_\_\_\_\_

**Installer's Name** \_\_\_\_\_

**Signature** \_\_\_\_\_



2201 Dwyer Avenue, Utica, NY 13501

Tel. 800 325 5479

[www.ecrinternational.com](http://www.ecrinternational.com)

All specifications subject to change without notice.

©2020 ECR International, Inc.