

**APPLICATION GUIDE  
FOR USE WITH  
HEATING ONLY - 100, 125, 165  
&  
COMBI - 115, 150, 205**

This manual has been prepared for use with the appropriate Installation, Operation and Maintenance Manual.



**Manufactured by:**  
ECR International Inc.  
2201 Dwyer Avenue, Utica, NY 13501  
Tel. 800 325 5479  
[www.ecrinternational.com](http://www.ecrinternational.com)  
PN 240011430 REV. P [09/15/2021]

## TABLE OF CONTENTS

<b>Important Safety Information</b> .....	<b>3</b>
<b>Labor Saving Piping Manifolds / Near Boiler Piping Connections</b> .....	<b>4</b>
<b>General Information - Hydronic Piping</b> .....	<b>6</b>
<b>General Information - Wiring</b> .....	<b>8</b>
<b>Piping and Wiring Diagrams</b>	
<b>Piping Legend</b> .....	<b>9</b>
100, 125 W/Zone Circulators & DHW Tank - Piping Diagram .....	10
100, 125 W/Indirect Zone Circulators, DHW Tank W/Sensor - Wiring Diagram .....	11
100, 125 W/Indirect Zone Circulators & DHW Tank W/T-Stat - Wiring Diagram .....	12
100, 125 With Zone Valves & DHW Tank - Piping Diagram.....	13
100, 125 With Zone Valves, DHW Tank W/Sensor - Wiring Diagram.....	14
100, 125 Zone Valves, DHW Tank W/T-Stat - Wiring Diagram .....	15
165 With Zone Circulators - Piping Diagram .....	16
165 Indirect Zone Circulators, DHW Tank W/ T-Stat - Wiring Diagram.....	17
165 With Zone Valves - Piping Diagram .....	18
165 With Indirect Zone Valves, DHW Tank, Tank T-Stat - Wiring Diagram .....	19
115, 150 & 205 With Zone Circulators - Piping Diagram.....	20
115, 150 & 205 With Zone Circulators - Wiring Diagram .....	21
115, 150 & 205 With Zone Valves - Piping Diagram.....	22
115, 150 & 205 With Zone Valves - Wiring Diagram .....	23
External Buffer Tank - Piping Diagram .....	24
External Buffer Tank - Wiring Diagram.....	26
<b>Optional Equipment</b> .....	<b>29</b>
Chart 1 -1k $\Omega$ Outdoor Air Sensor Data .....	29
Chart 2 -10k $\Omega$ Indirect Tank Sensor Data .....	29
<b>Accessories</b> .....	<b>30</b>
Outdoor Temperature Sensor .....	30
Indirect Storage Tank Sensor & Thermostat .....	30
<b>Wiring Diagrams</b>	
Single Zone Circulator Wiring Using Argo AR822-I.....	32
100 - Heat Only Wiring Diagram .....	33
125 - Heat Only Wiring Diagram .....	34
165 - Heat Only Wiring Diagram .....	35
115 - Combi Wiring Diagram .....	36
150 - Combi Wiring Diagram .....	37
205 - Combi Wiring Diagram .....	38
<b>Altitude Effects On Boiler Performance</b> .....	<b>39</b>
<b>Application Table - Indirect Hot Water Tank Performance Chart</b> .....	<b>40</b>
<b>LWCO Wiring Diagram</b> .....	<b>41</b>
<b>Piping Diagram -LWCO Location</b> .....	<b>42</b>
<b>Low Water Cutoff - Detail</b> .....	<b>43</b>
<b>Error Code Table</b> .....	<b>44</b>
<b>Troubleshooting Chart</b> .....	<b>45</b>
<b>Fault Solution Sections</b> .....	<b>47</b>
<b>Parameter Change History</b> .....	<b>51</b>

## IMPORTANT SAFETY INFORMATION

### 1. Become familiar with symbols identifying potential hazards.



This is the safety alert symbol. Symbol alerts you to potential personal injury hazards. Obey all safety messages following this symbol to avoid possible injury or death.

#### **DANGER**

Indicates a hazardous situation which, if not avoided, WILL result in death or serious injury.

#### **WARNING**

Indicates a hazardous situation which, if not avoided, could result in death or serious injury.

#### **CAUTION**

Indicates a hazardous situation which, if not avoided, could result in minor or moderate injury.

### 2. General

Boiler installation shall be completed by qualified agency. See Installation, Operation & Maintenance Manual for additional information.

#### **WARNING**

Fire, explosion, asphyxiation and electrical shock hazard. Improper installation could result in death or serious injury. Read this manual and understand all requirements before beginning installation.

#### **WARNING**

Fire, Explosion, Asphyxiation, Electrical shock hazard! Flooding will result in damages such as electrical problems, corrosion, inoperative parts, mold and other unforeseen issues which can occur over time. Any equipment determined by a professional as damaged by a flood, defined as excess of water or other liquid, shall be replaced. Failure to follow these directions will result in a Hazardous Situation.

### 3. Installation shall conform to requirements of authority having jurisdiction or in absence of such requirements:

- *United States*
  - National Fuel Gas Code, ANSI Z223.1/NFPA 54.
  - National Electrical Code, NFPA 70.
- *Canada*
  - Natural Gas and Propane Installation Code, CAN/CSA B149.1.
  - Canadian Electrical Code, Part I, Safety Standard for Electrical Installations, CSA C22.1

### 4. Where required by authority having jurisdiction, installation shall conform to Standard for Controls and Safety Devices for Automatically Fired Boilers, ANSI/ASME CSD-1.

Additional manual reset low water cutoff and/or high limit may be required.

### 5. Requirements for Commonwealth of Massachusetts:

Boiler installation must conform to Commonwealth of Massachusetts code 248 CMR which includes but is not limited to:

- Installation by licensed plumber or gas fitter.

**LABOR SAVING PIPING MANIFOLDS / NEAR BOILER PIPING CONNECTIONS**

**100 & 125 HEATING ONLY  
WITH OPTIONAL INDIRECT DHW**

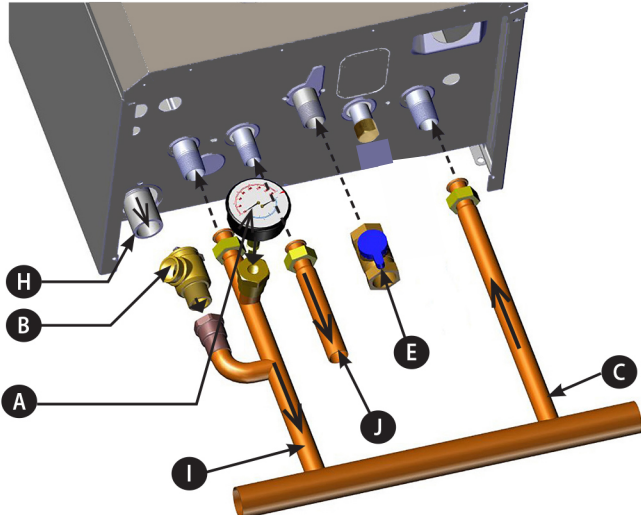

**165 HEATING ONLY**

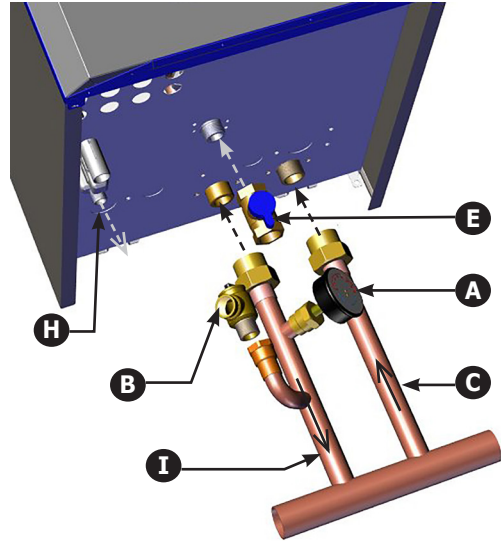

**100 & 125 HEATING ONLY  
WITHOUT OPTIONAL INDIRECT  
DHW CONNECTION**

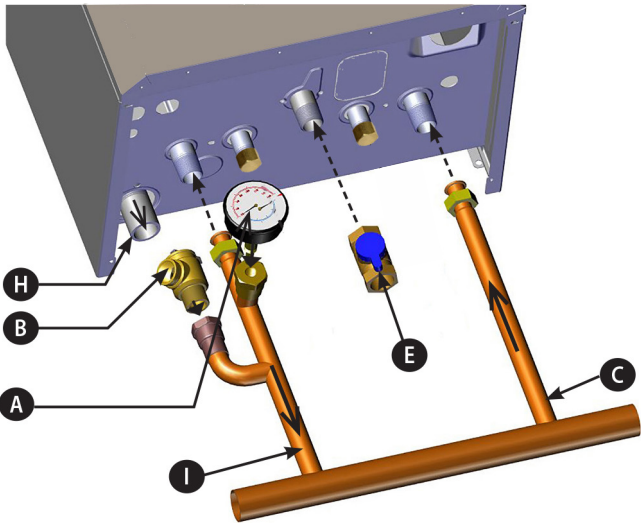

LEGEND		100/125	165
A	Pressure Gauge	-	
B	Pressure Relief Valve	30.00 psi [2.11 bar]	
C	Heating return connection	3/4" [22.2mm]	1" [25.4mm]
E	Gas shutoff connection	3/4" [22.2mm]	
H	Drain connection for condensate	13/16" [21mm] ID Hose	3/4 NPT
I	Heating supply connection	3/4" [22.2mm]	1" [25.4mm]
J	Optional Indirect DHW connection	3/4" [22.2mm]	na

**MANIFOLD  
100/125/115/150**

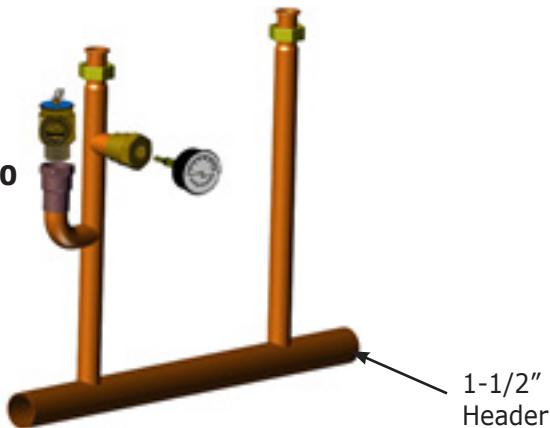

**MANIFOLD  
165**

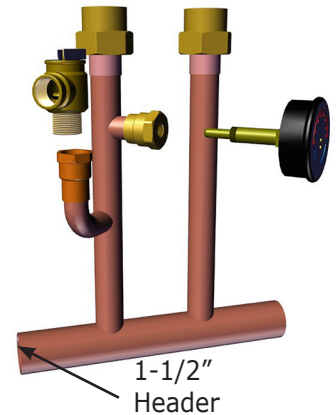

# LABOR SAVING PIPING MANIFOLDS / NEAR BOILER PIPING CONNECTIONS

## 115 & 150 COMBI

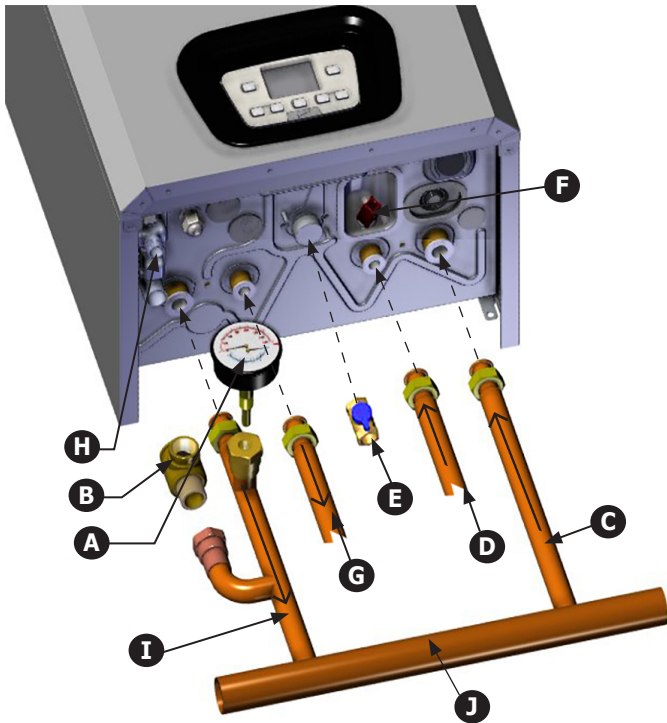

## 205 COMBI

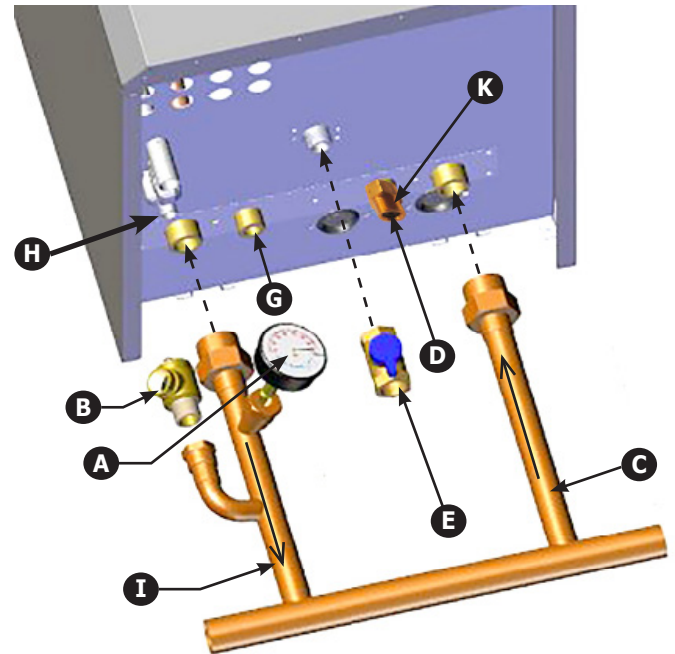

LEGEND		115 & 150	205
A	Pressure Gauge		-
B	Pressure Relief Valve	30.00 psi [2.11 bar]	
C	Heating return connection	3/4" [22.2mm]	1" [25.4mm]
D	Cold DHW inlet tap	1/2" [15.9mm]	3/4" NPT
E	Gas shutoff connection	3/4" [22.2mm]	
F	Cold DHW inlet tap	1/2" [15.9mm]	na
G	DHW outlet	1/2" [15.9mm]	3/4" NPT
H	Drain connection for condensate	13/16" [21mm] ID Hose	3/4 NPT
I	Heating supply connection	3/4" [22.2mm]	1" [25.4mm]
J	Manifold	1-1/4" [31.75 mm]	1-1/2" [38.1 mm]
K	5 gpm DHW flow restrictor (Factory installed) (205 only)	na	3/4" [22.2mm]

## MANIFOLD 205

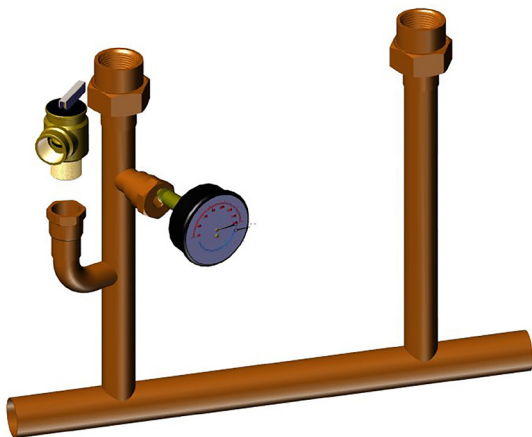

## GENERAL INFORMATION - HYDRONIC PIPING

### **⚠ WARNING**

Burn and scald hazard! Manufacturer requires installation of field supplied anti-scald valve. Failure to follow these instructions could result in death or serious injury.

#### **General Information:**

Piping installation, materials, and joining methods shall conform to requirements of authority having jurisdiction or in absence of such requirements:

- **USA** - National Fuel Gas Code, ANSI Z223.1/NFPA 54
- **Canada** - Natural Gas and Propane Installation Code, CAN/CSA B149.1

#### **Manufacturer Requirements/Recommendations:**

- **Manufacturer requires all domestic hot water (DHW) installations use an anti-scald valve.** Local codes may require additional equipment (expansion tank, relief valves, etc.) Select and size equipment to suit installation and meet code requirements.
- Use a water filter on potable incoming water supply line.
- Manufacturer recommends use of a magnetic dirt separator in the hydronic system where there are cast iron or steel components, or where the previous boiler was a cast iron heat exchanger. The abrasive, extremely fine sediment is difficult to remove and can deposit onto heat exchanger surfaces and accumulate in pump cavities causing reduced efficiency and premature wear.
- If the piping manifold is not used the ASME temperature and pressure relief valve and temperature and pressure gauge shall be installed to conform to requirements of the authority having jurisdiction. Refer to appropriate manufacturer instructions for installation requirements.
- If the piping manifold is not used, a primary / secondary piping arrangement is manufacturer required, unless using Buffer Tank. A maximum of 12 in of separation between the supply and return pipe (closely spaced tees) of the boiler shall be maintained. Limit combined supply and return pipe lengths to maximum linear lengths of 20 ft (6.1 m) between boiler and closely spaced tees, when minimum ¾ in NPT pipe size is used. Linear length may be increased if supply and return pipe size is increased to limit pressure drop.
- Manufacturer recommends installing a shutoff and purge valve to use during commissioning to ensure the boiler does not shut down due to over temperature. Do not install shutoff between boiler and LWCO or pressure relief valve.

FOR YOUR SAFETY READ BEFORE OPERATING



#### **Hot Water Can Scald!**

Water heated to temperature for clothes washing, dish washing and other sanitizing needs can scald and cause permanent injury.

Children, elderly, and infirmed or physically handicapped persons are more likely to be permanently injured by hot water. Never leave them unattended in bathtub or shower. Never allow small children to use a hot water tap or draw their own bath.

If anyone using hot water in the building fits the above description, or if state laws or local codes require certain water temperatures at hot water taps, you must take special precautions:

- Use lowest possible temperature setting.
- Install some type of tempering device, such as an automatic mixing valve, at hot water tap or water heater. Automatic mixing valve must be selected and installed according to manufacturer's recommendations and instructions.
- Water passing out of drain valves may be extremely hot. To avoid injury:
  - ◇ Make sure all connections are tight.
  - ◇ Direct water flow away from any person.

## GENERAL INFORMATION - HYDRONIC PIPING

Water Temperature Setting	1st Degree Burn Exposure Time For An Adult	2nd and 3rd Degree Burn Exposure Time For An Adult
120° F	1 minute	5 minutes
130° F	5 seconds	30 seconds
140° F	2 seconds	5 seconds
150° F	1 second	1.5 seconds
160° F	Instantaneous	0.5 seconds

**Note:** Warning for Infants, Children, and Elderly: Great care must be taken when exposing the aforementioned groups to warm or hot water as they can be badly burned in exposure times less than half of the time for an adult.

### Note

Provided Wiring and Piping illustrations are meant to show system concepts only. Installer is responsible for all equipment required by authority having jurisdiction.

### Note

Arrange piping to prevent water dripping onto boiler.

All piping diagrams are shown with optional DHW Indirect Tank where applicable.

The Labor Saver Piping Manifold, which is supplied with each boiler, is shown with most of the following piping diagrams.

### Use of Indirect Water Heater (DHW) Heating Only Boiler:

#### Note

Sensors supplied with this boiler are proprietary to the manufacturer. Use of alternate sensors *WILL* diminish boiler performance.

- Use DHW sensor kit 550003189 to interface with boiler. Wire to M2 terminals #3 and #4. Exception: not applicable for the 165 model, use aquastat for indirect tank control.
- For heating only boilers with DHW outlet connection, see page 4, indirect water heater shall be piped utilizing the internal boiler pump. See pages 10 and 13.
- Locate tank as close to boiler as possible.
- See Indirect Tank Performance chart, page 40 of this manual.
- Change P03 on boiler for application as specified on the applicable wire diagram in this manual or Boiler Control Section 9 of Installation, Operation & Maintenance Manual supplied with the boiler.

### Use of Buffer Tank:

- If using internal boiler pump, manifold shall be cut for use as shown on page 24, increase pipe size to match Buffer tank connections as shown.
- Locate tank as close to boiler as possible.

## GENERAL INFORMATION - WIRING

### Electrical Wiring Information:

All field wiring shall conform to the authority having jurisdiction or, in the absence of such requirements to:

- **USA:** National Electrical Code, ANSI/NFPA 70,
- **Canada:** Canadian Electrical Code, Part I, CSA C22.1: Safety Standard for Electrical Installations.

Wiring diagrams shown in this manual utilize ARGO™ Controls, the **optional** use of an Indirect Domestic Hot Water Tank, and **optional** use of a H2O Buffer Tank.

Reference the zone control manufacturer instruction manual for control operation and priority setting of DHW zones.

**Note** → **DO NOT** use 120 V thermostat terminals (M1- #1 and #2).

**Note** → **Provided Wiring and Piping illustrations are meant to show system concepts only. Installer is responsible for all equipment required by authority having jurisdiction.**

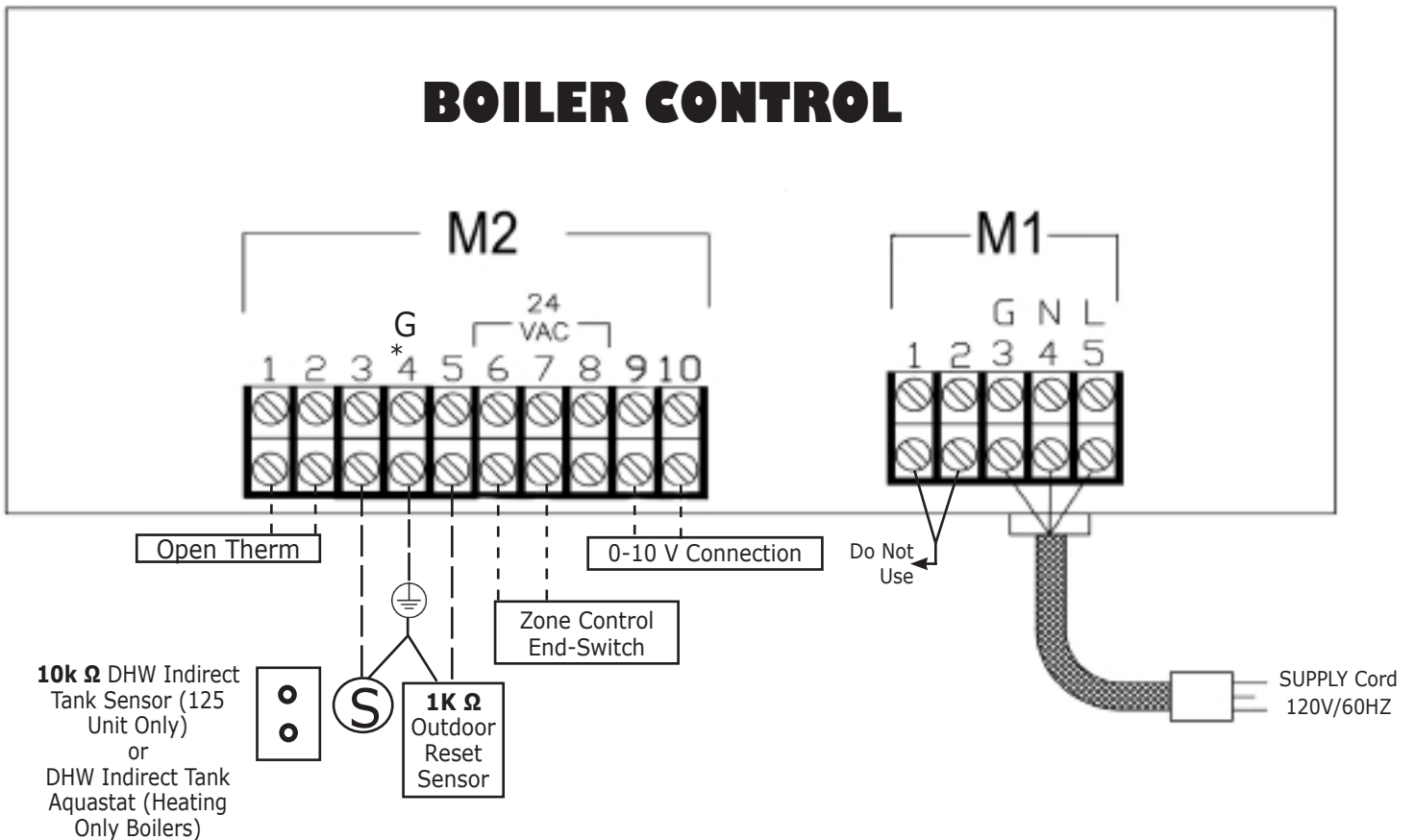

\* Ground Sensors using terminal 4



# PIPING LEGEND

## PIPING LEGEND

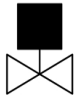

ZONE VALVE



BALL VALVE

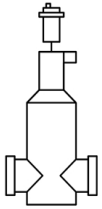

AIR SEPARATOR



CIRCULATOR



DRAIN

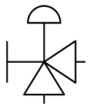

COMBINATION FILL



FLOW CHECK VALVE



BYPASS VALVE



DIVERTER VALVE



T&P OR RELIEF VALVE



THERMOSTATIC MIXING VALVE

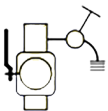

PURGE VALVE

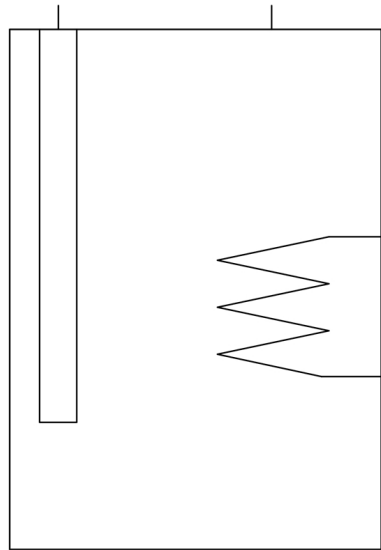

DHW INDIRECT TANK



INDIRECT TANK AQUASTAT



**10K  $\Omega$**  INDIRECT DHW TANK SENSOR



TEMPERATURE & PRESSURE GAUGE

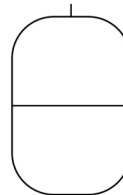

EXPANSION TANK

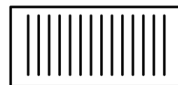

FLAT PLATE HEAT EXCHANGER  
(COMBI ONLY)



STRAINER

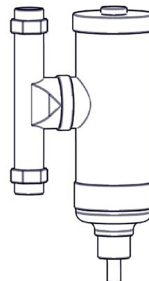

MAGNETIC DIRT SEPARATOR

100 & 125 W/ ZONE CIRCULATORS & DHW TANK- PIPING DIAGRAM

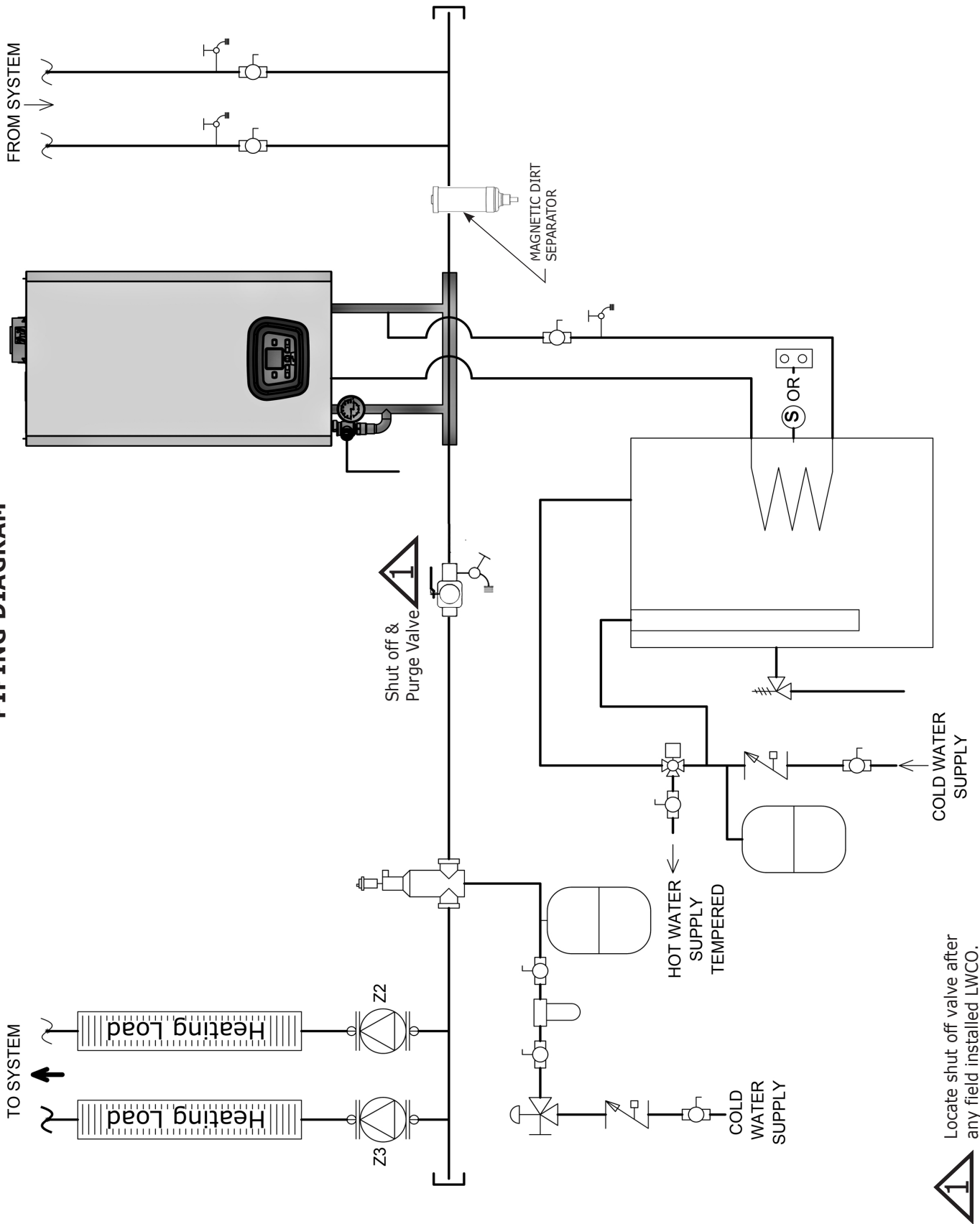

100 & 125 WITH INDIRECT ZONE CIRCULATORS & DHW TANK W/SENSOR, ARGO UZ3 ZONE CONTROL

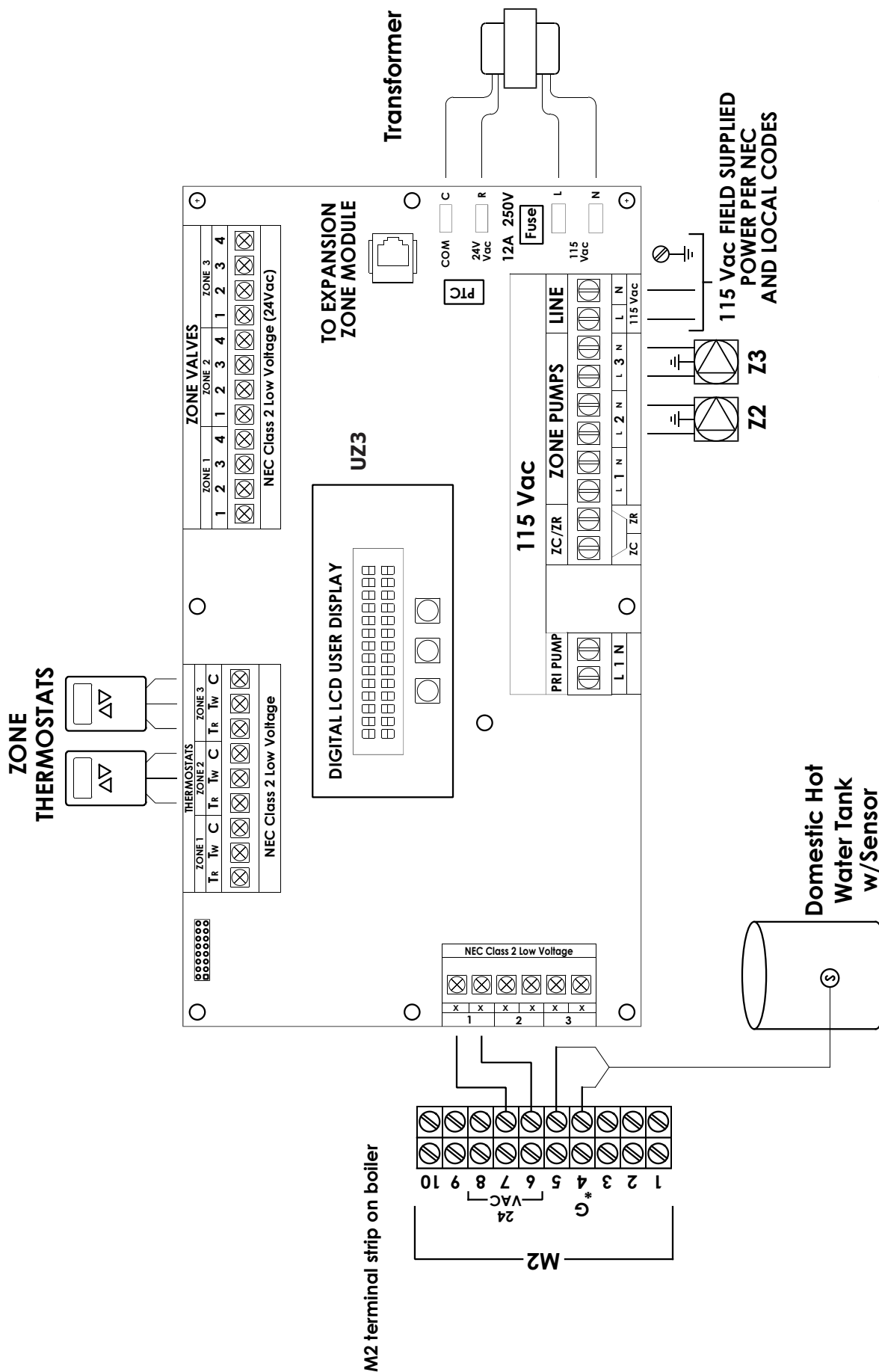

Reference zone control manufacturer instructions for details on setting priority if necessary.

If adding an indirect tank with **sensor** to a **Heating Only Boiler**, change P03 from 08 to 05. See Section 9, Parameter Settings in Boiler Installation, Operation & Maintenance Manual for details.

# 100 & 125 W/ INDIRECT ZONE CIRCULATORS & DHW TANK W/T-STAT, ARGO UZ3 ZONE CONTROL WIRING DIAGRAM

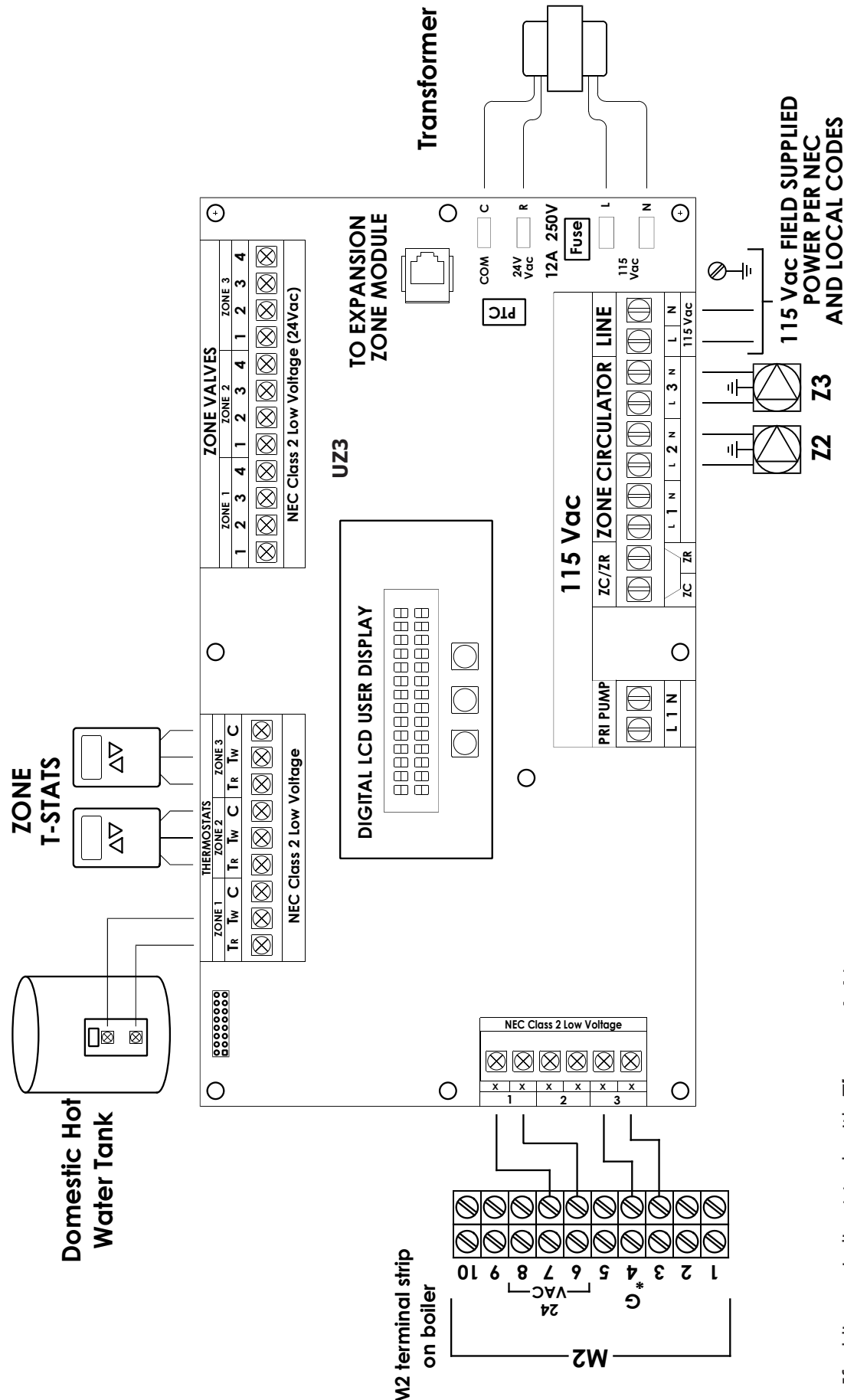

Reference zone control manufacturer instructions for details on setting priority if necessary.

If adding an indirect tank with **Thermostat** to a **Heating Only Boiler**, change P03 from 08 to 04. See Section 9, Parameter Settings in Boiler Installation, Operation & Maintenance Manual for details.

100, 125 WITH ZONE VALVES & DHW TANK - PIPING DIAGRAM

100 & 125 WITH ZONE VALVES & DHW TANK

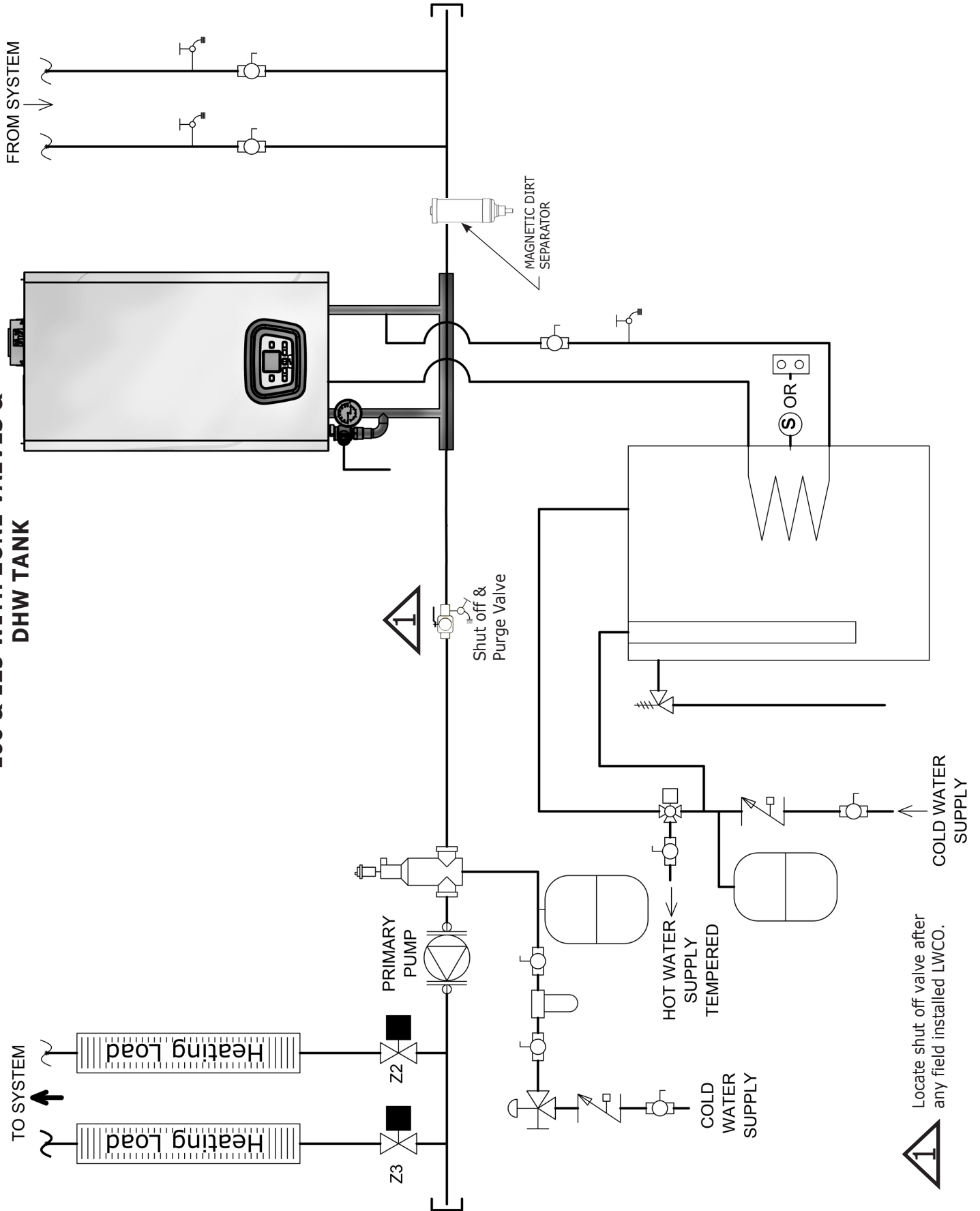





165 WITH ZONE CIRCULATORS - PIPING DIAGRAM

165 WITH ZONE CIRCULATORS

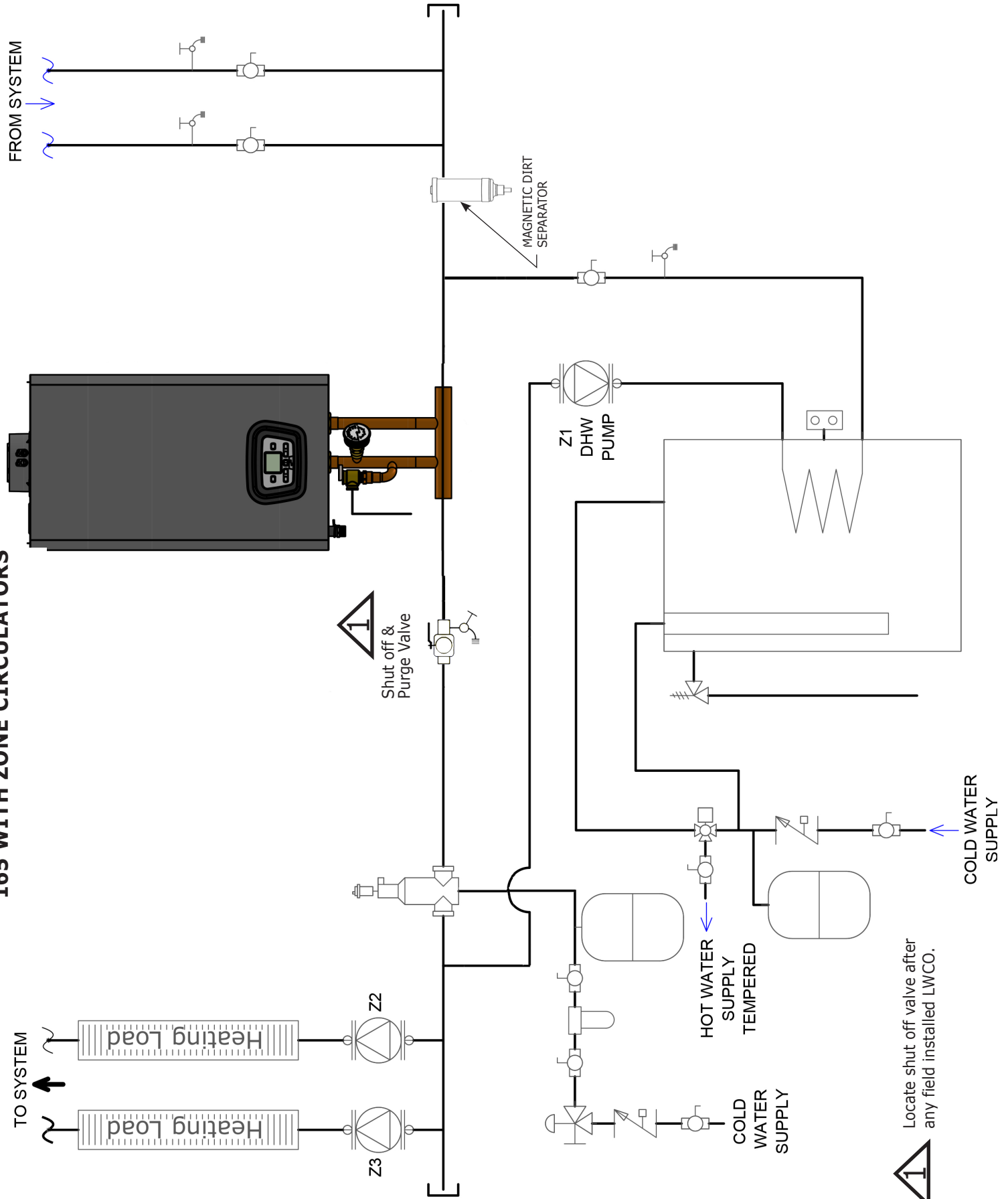



165 ZONE CIRCULATORS, DHW TANK, TANK T-STAT, ARG0 UZ3 ZONE CONTROL

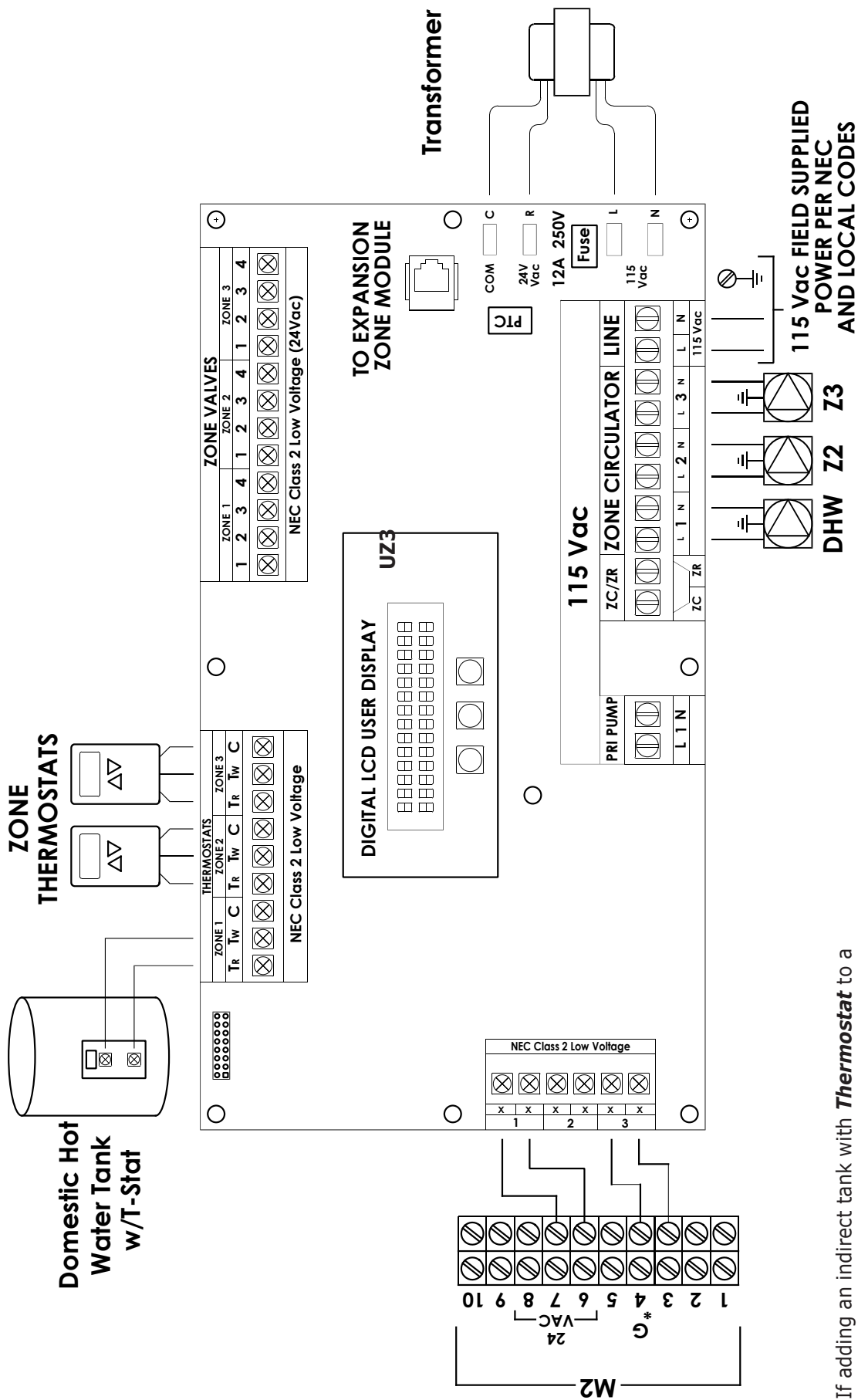

Reference zone control manufacturer instructions for details on setting priority if necessary.

If adding an indirect tank with **Thermostat** to a **Heating Only Boiler**, change P03 from 08 to 04. See Section 9, Parameter Settings in Boiler Installation, Operation & Maintenance Manual for details.

# 165 WITH ZONE VALVES - PIPING DIAGRAM

## 165 WITH ZONE VALVES

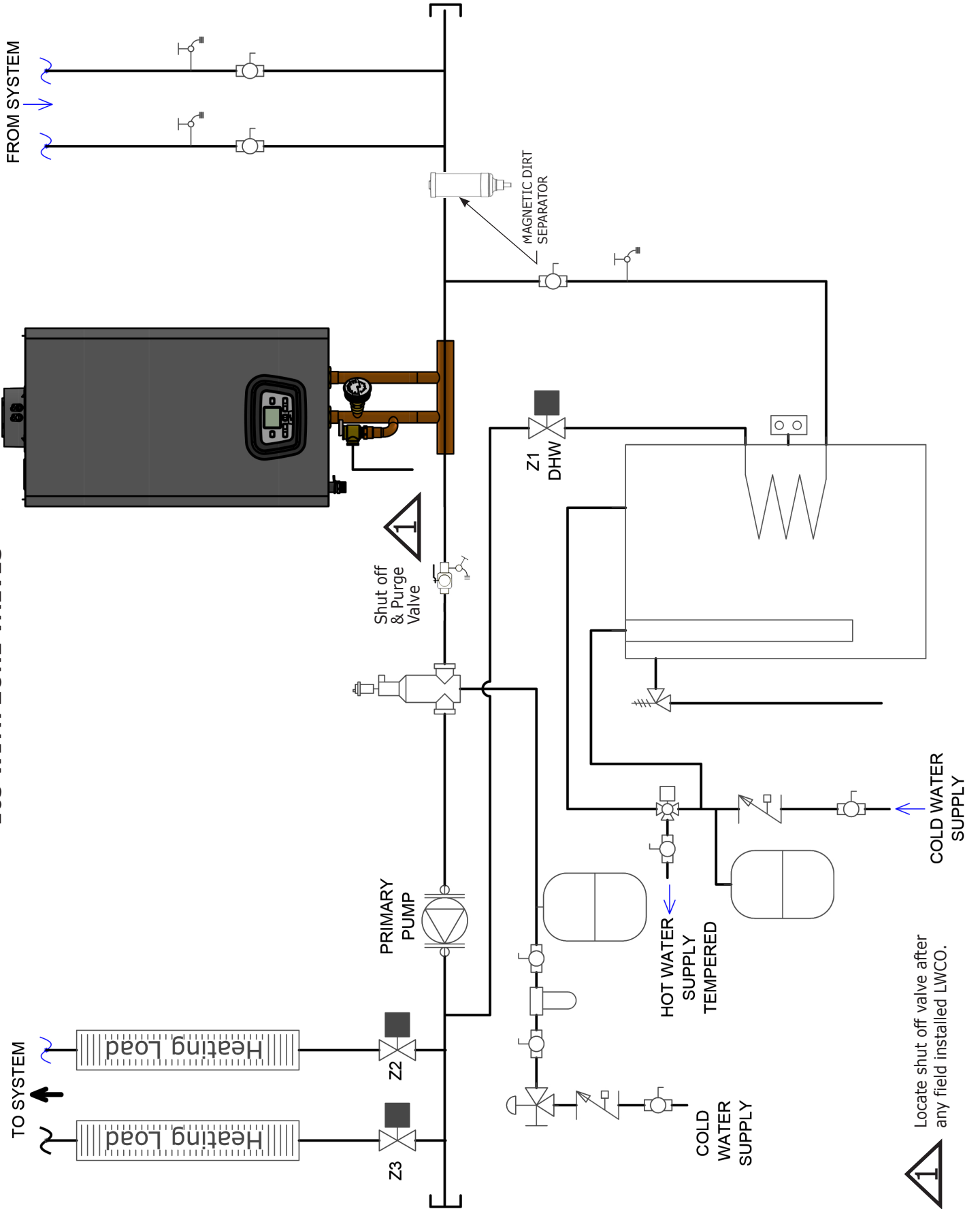

Locate shut off valve after any field installed LWCO.



115, 150 & 205 WITH ZONE CIRCULATOR PUMPS

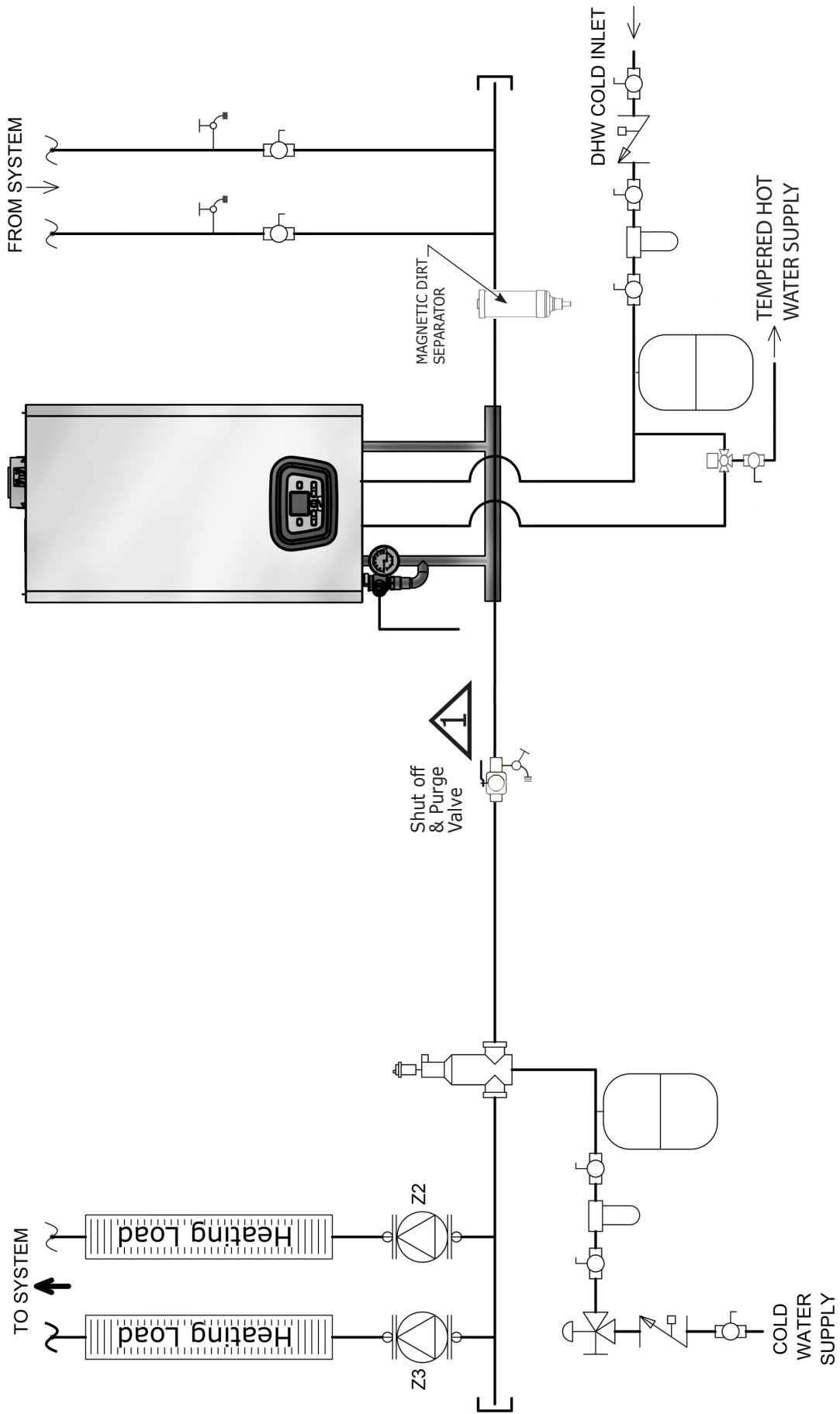

Locate shut off valve after any field installed LWCO.



115, 150 & 205 WITH ZONE CIRCULATORS, ARGO UZ3 ZONE CONTROL

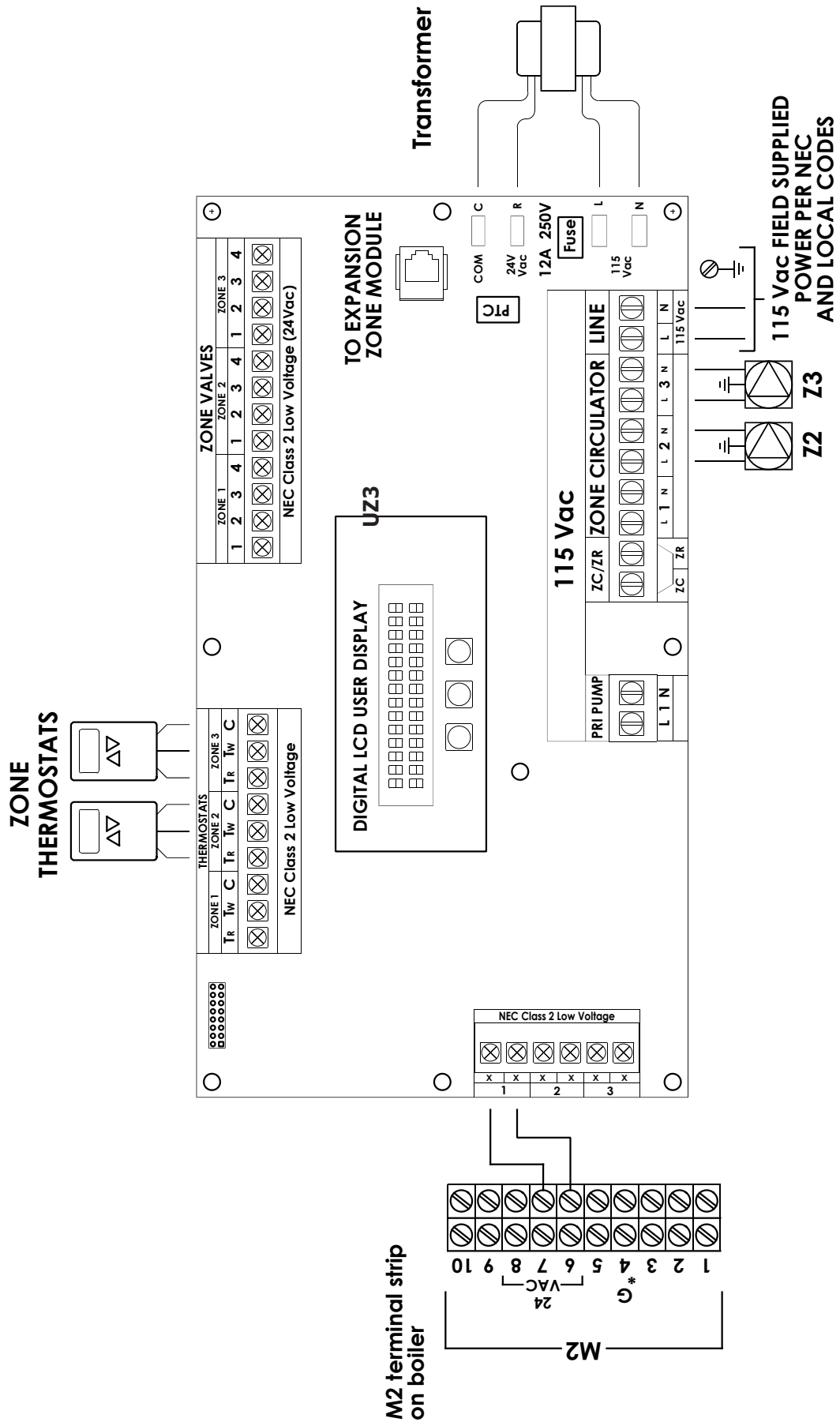

115, 150 & 205 WITH ZONE VALVES

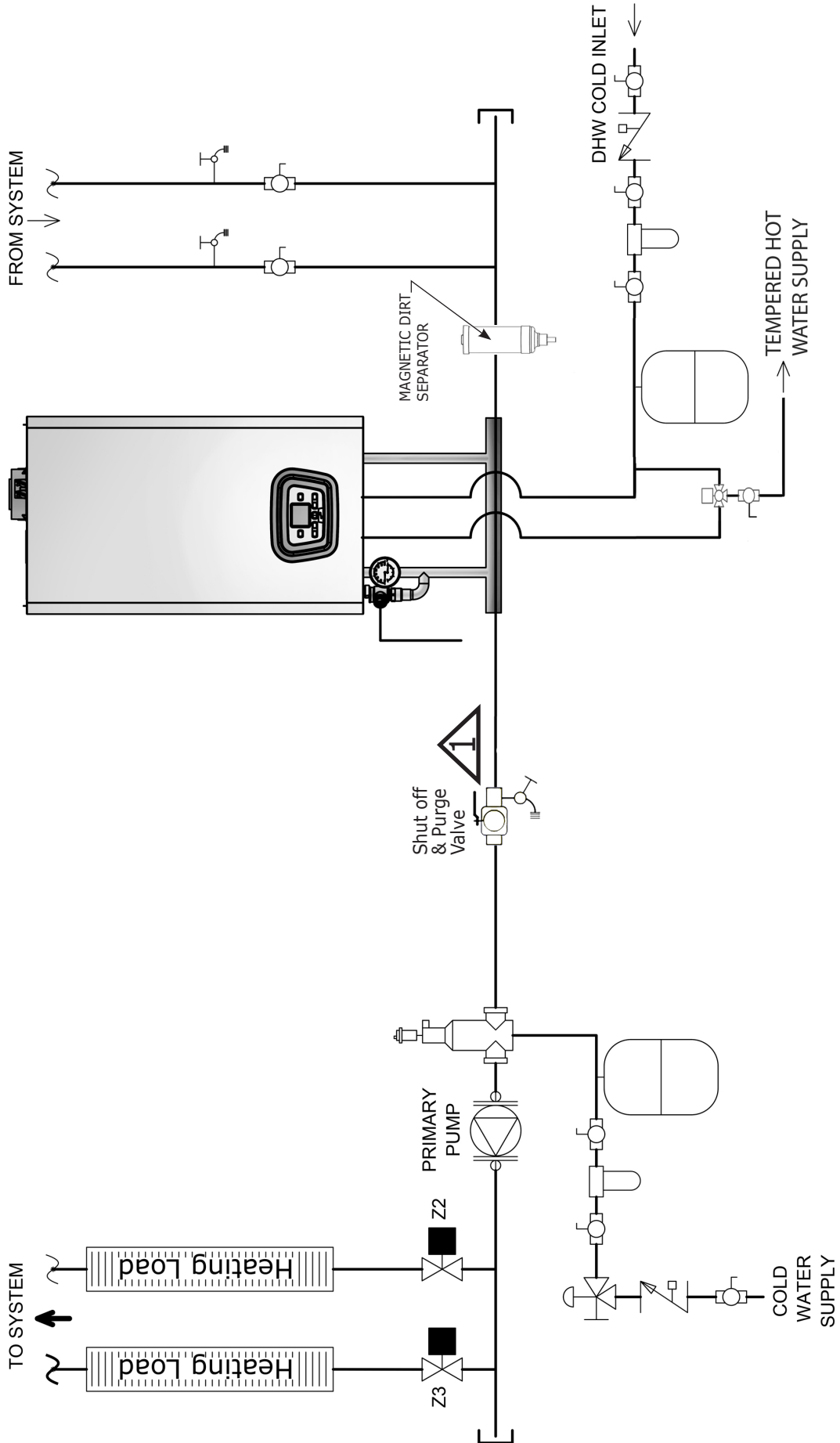

1 Locate shut off valve after any field installed LWCO.

115, 150 & 205 WITH ZONE VALVES, ARGO UZ3 ZONE CONTROL

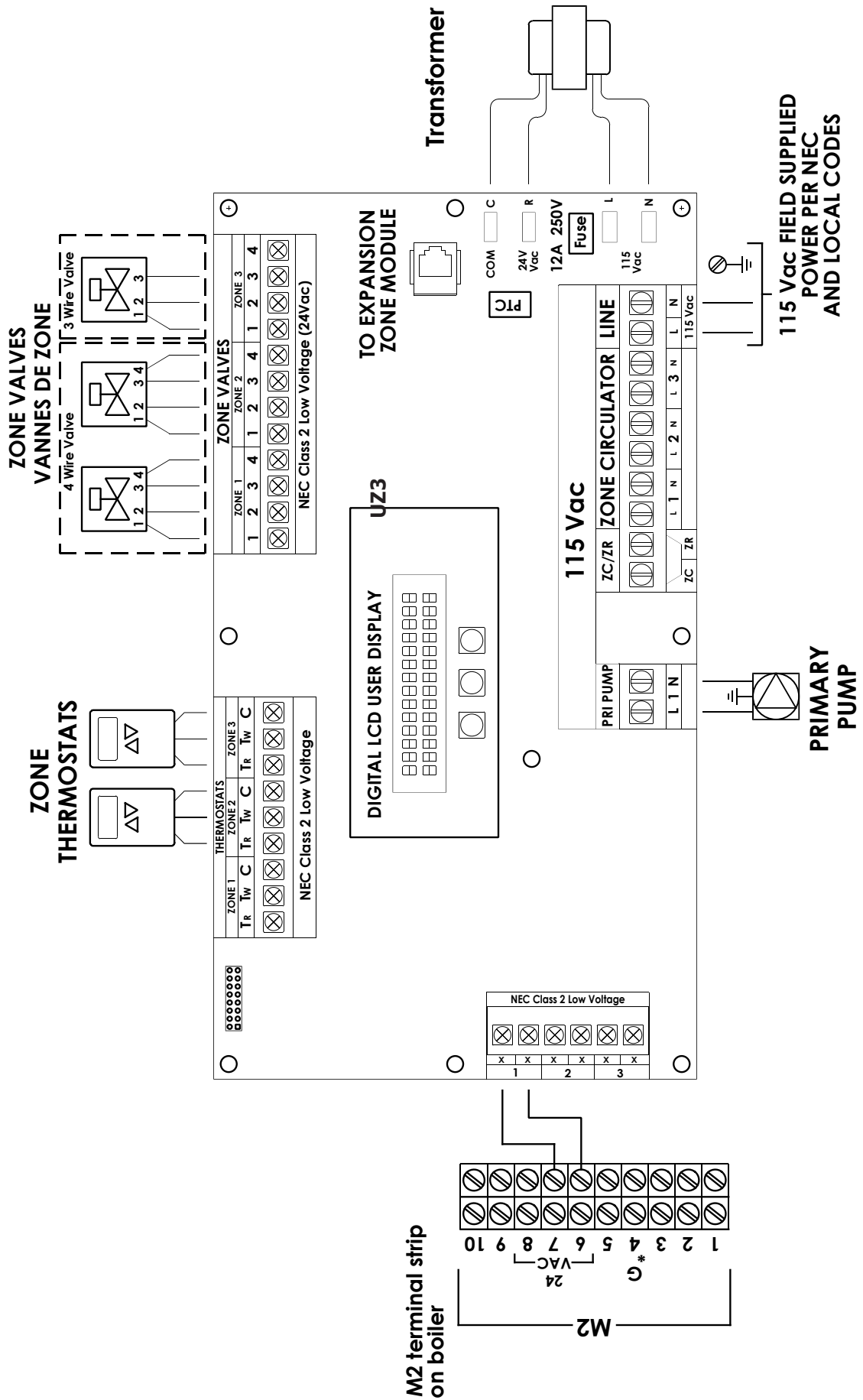

**Buffer Tank Piping**

When installing low mass systems, additional water mass may be required to avoid short cycling by the boiler. In these applications it is recommended that a buffer tank be installed.

**Buffer Tank on Central Heat Circuit Using Internal Boiler Circulator**

**Note:**

- DHW piping not shown for clarity. Reference applicable sections of this manual for DHW piping details.
- Internal Boiler circulator used on Primary circuit.

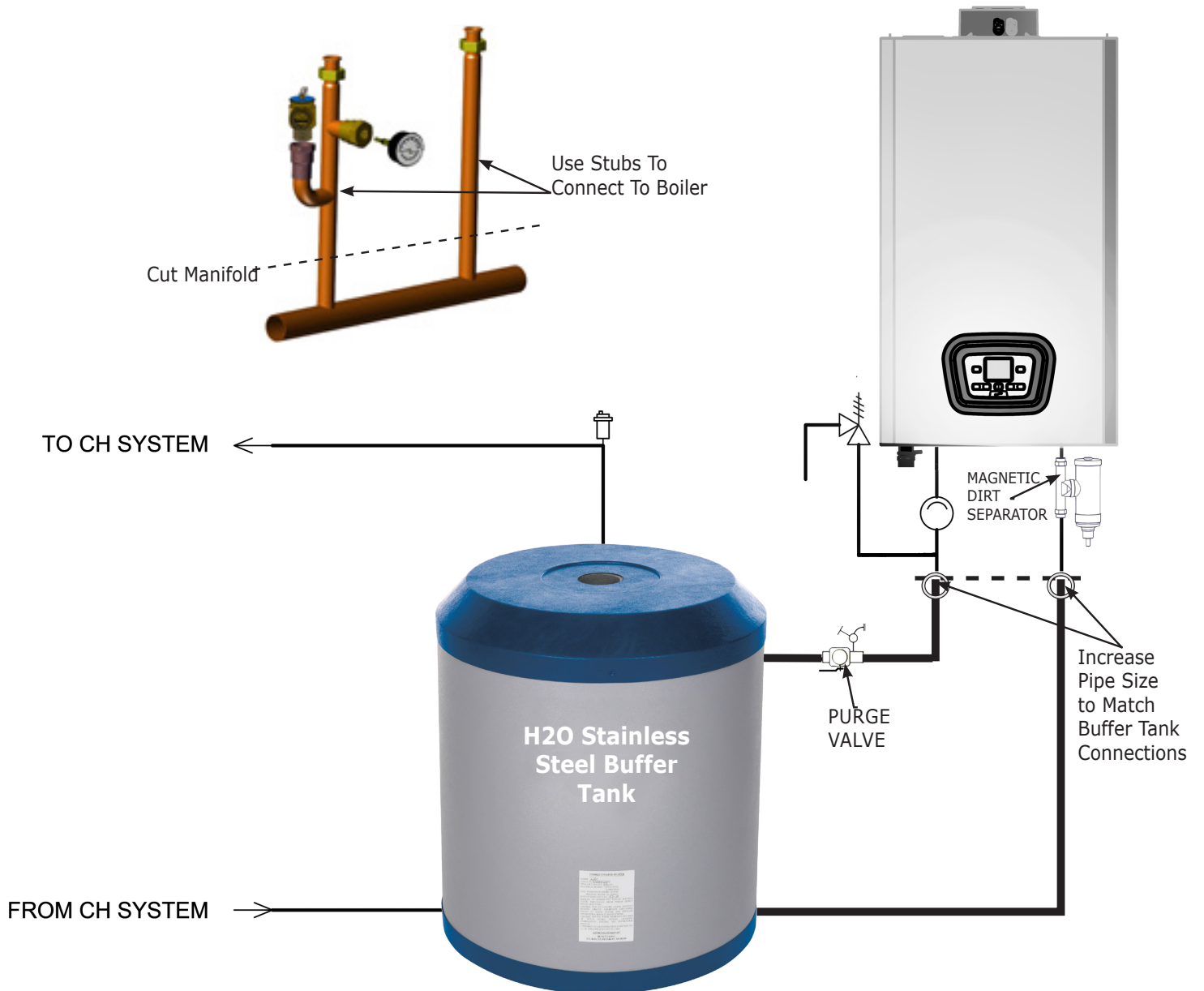



Buffer Tank On Central Heat Circuit With Primary Pump and Supplied Manifold

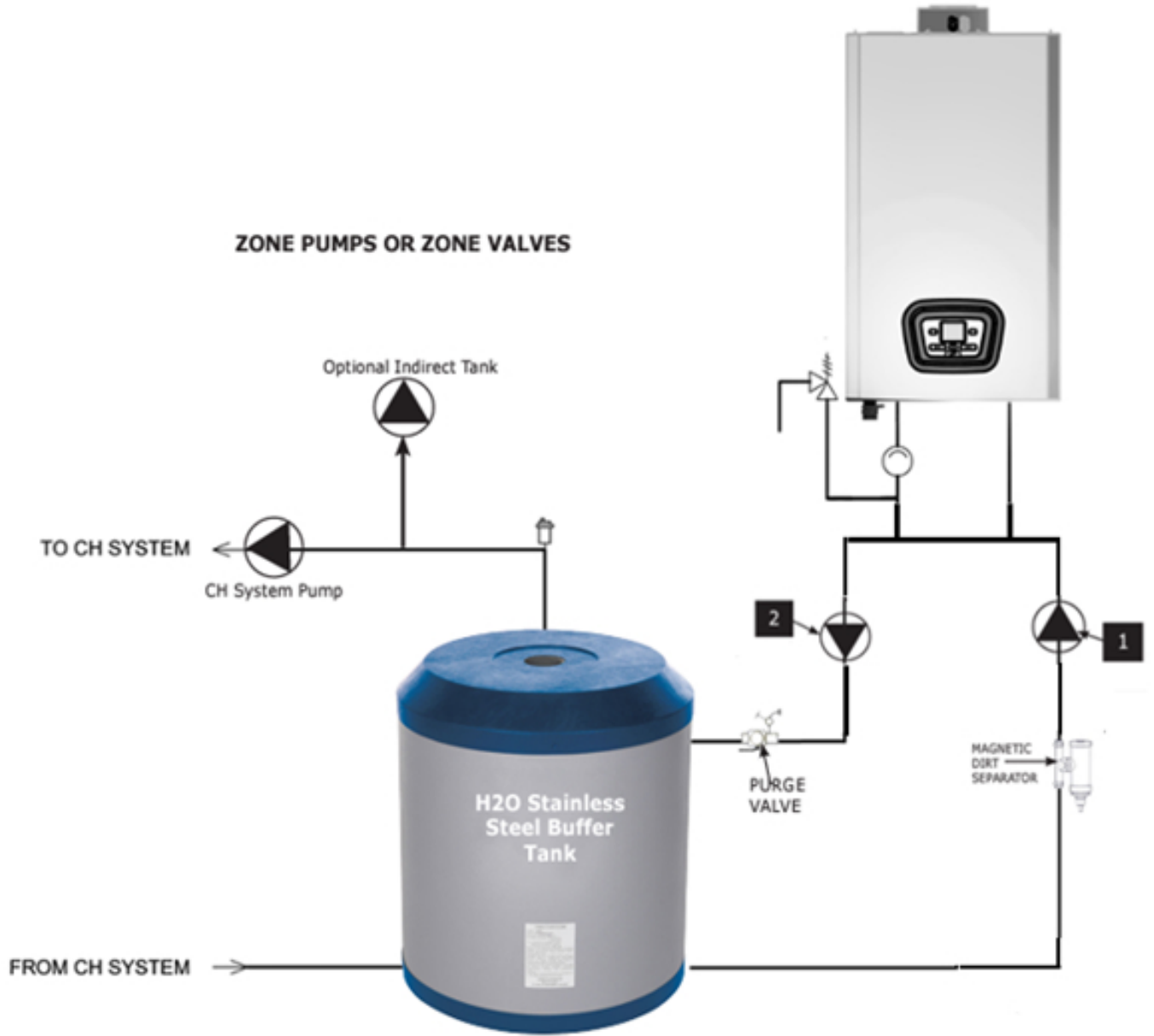

**NOTE :** Acceptable primary pump locations: Either 1 **or** 2.  
For pump wiring see diagrams on pages 26-29.

Buffer Tank Pump Wiring

Controlling A Primary Pump On A Combi Boiler With Zone Valves, No Indirect Tank



# EXTERNAL BUFFER TANK - WIRING DIAGRAM

## Buffer Tank Pump Wiring

### Controlling A Primary Pump On A Combi Boiler With Zone Pumps, Argo ARM 4P Zone Control and A822-II

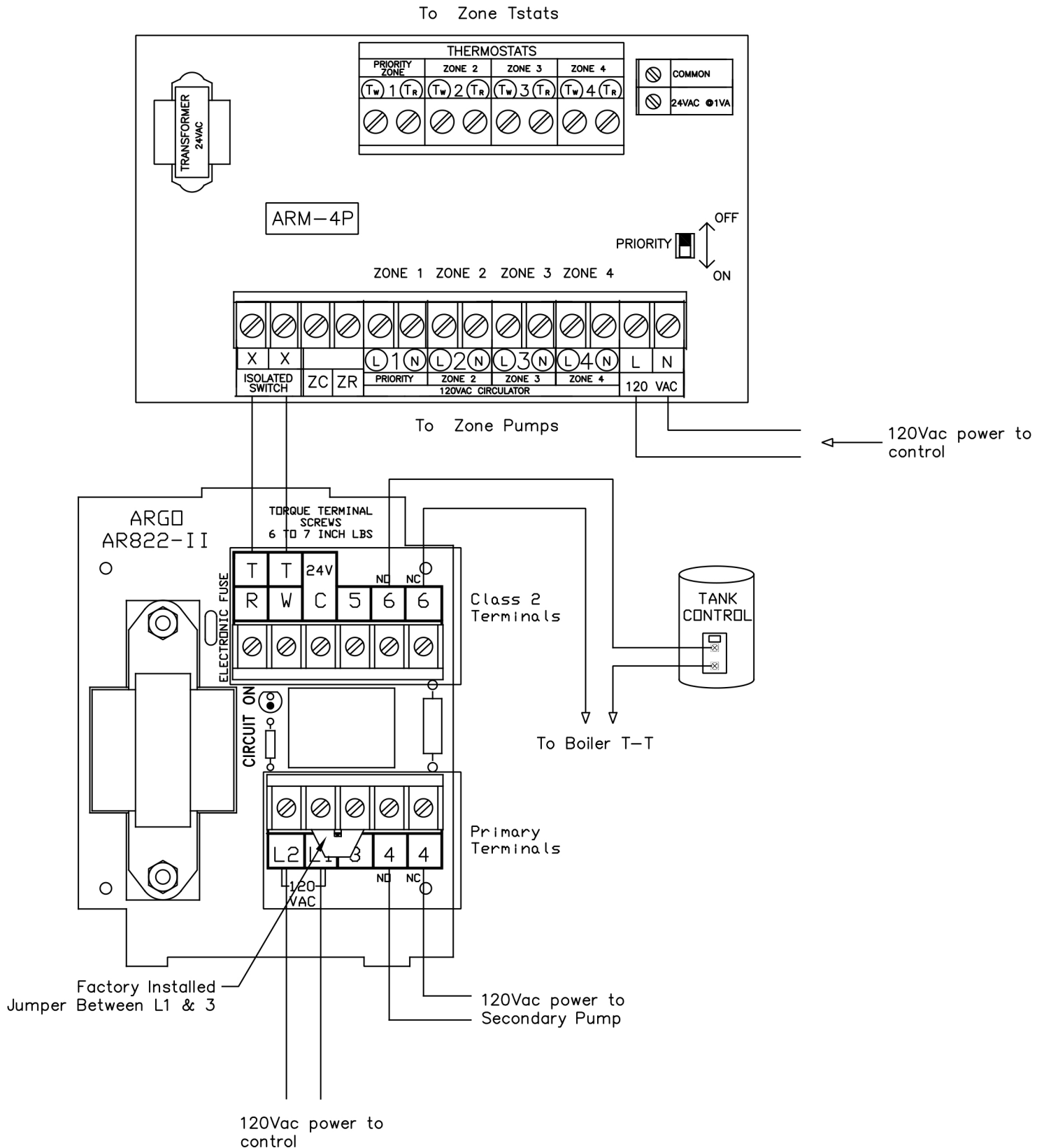

# EXTERNAL BUFFER TANK - WIRING DIAGRAM

## Buffer Tank Pump Wiring

### Controlling A Primary Pump On A Combi Boiler With Zone Valves and Indirect Tank With Priority Argo UZ3 and AR22II Zone Controls

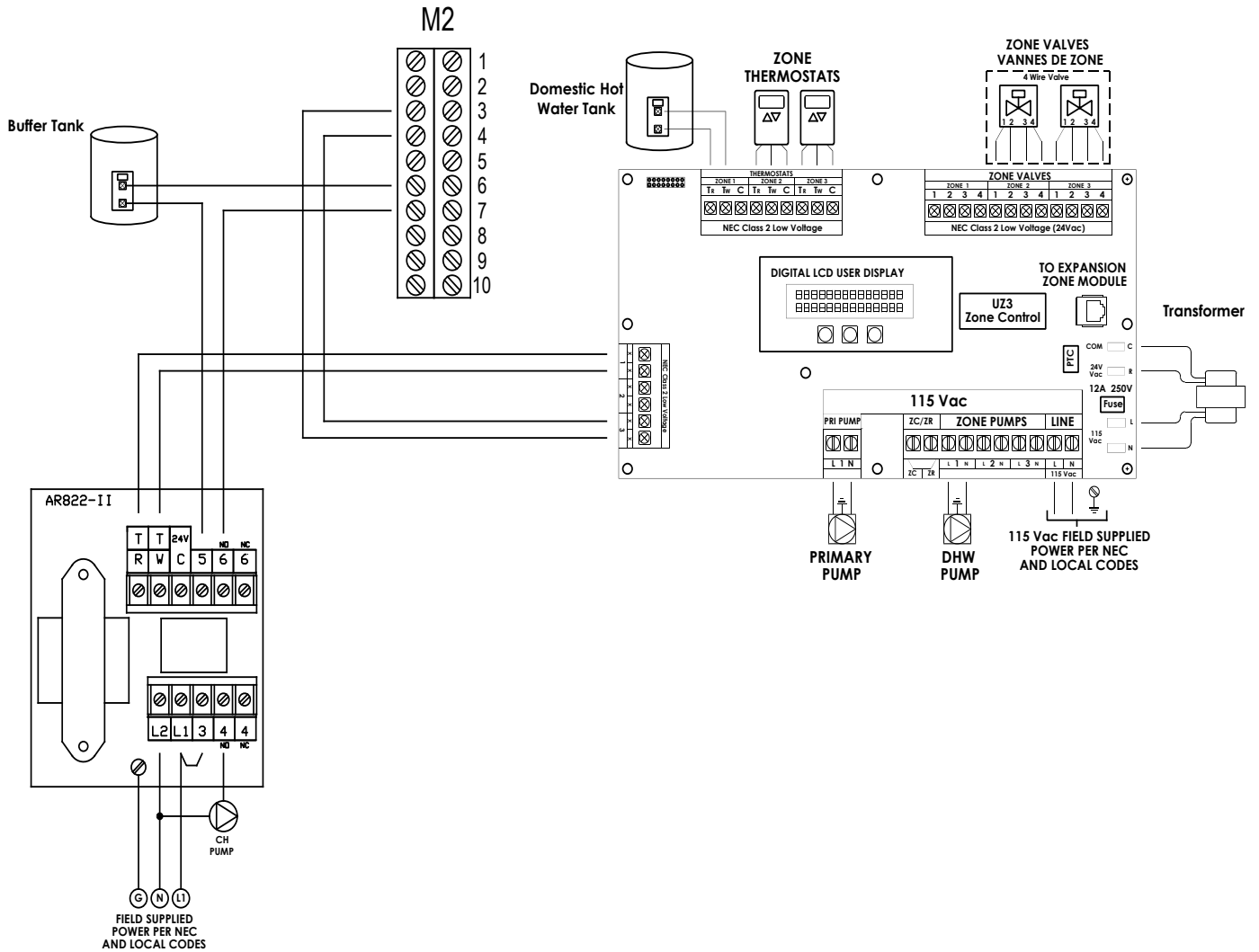

## OPTIONAL EQUIPMENT

### Optional Equipment

**IMPORTANT:** Sensors supplied with this boiler are proprietary to the manufacturer. Use of alternate market sensors *WILL* diminish boiler performance.

1. **1k  $\Omega$**  Outdoor Air Sensor, if used.
  - A. Boiler automatically recognizes sensor when used.
  - B. See Chart 1 for sensor data. Sensor part number BD710487302V
  - C. Locate outdoor sensor to protect against wind and direct sunlight. Mounting instructions provided with sensor.
  - D. Maximum wire length is 100 ft (30m) for 22 ga. wire, or 150 ft (45m) for 18 ga. wire.
  - E. Connect wires to M2 OUTDOOR SENSOR terminals 4 & 5. Wires are interchangeable. See Accessories.
  
2. **10k  $\Omega$**  Sensor for Indirect DHW Tank (Heating Only Boiler, Exception: not applicable to the 165 model, use aquastat for indirect tank control.).
  - A. See Chart 2 for sensor data.
  - B. Connect wires to M2 terminals 3 & 4.

CHART 1 -1k $\Omega$ OUTDOOR AIR SENSOR DATA			
T [°F]	R [Ohm]	T [°F]	R [Ohm]
-4.0	7,578	53.6	1,690
-2.2	7,193	55.4	1,621
-0.4	6,831	57.2	1,555
1.4	6,489	59.0	1,492
3.2	6,166	60.8	1,433
5.0	5,861	62.6	1,375
6.8	5,574	64.4	1,321
8.6	5,303	66.2	1,268
10.4	5,046	68.0	1,218
12.2	4,804	69.8	1,170
14.0	4,574	71.6	1,125
15.8	4,358	73.4	1,081
17.6	4,152	75.2	1,040
19.4	3,958	77.0	1,000
21.2	3,774	78.8	962
23.0	3,600	80.6	926
24.8	3,435	82.4	892
26.6	3,279	84.2	858
28.4	3,131	86.0	827
30.2	2,990	87.8	796
32.0	2,857	89.6	767
33.8	2,730	91.4	740
35.6	2,610	93.2	713
37.4	2,496	95.0	687
39.2	2,387	96.8	663
41.0	2,284	98.6	640
42.8	2,186	100.4	617
44.6	2,093	102.2	595
46.4	2,004	100.4	617
48.2	1,920	102.2	595
50.0	1,840	104.0	575
51.8	1,763	106.0	556

CHART 2 -10k $\Omega$ INDIRECT TANK SENSOR DATA			
T [°F]	R [Ohm]	T [°F]	R [Ohm]
32.0	32,505	86.0	8,060
33.8	30,898	87.8	7,726
35.6	29,381	89.6	7,407
37.4	27,946	91.4	7,103
39.2	26,590	93.2	6,813
41.0	25,308	95.0	6,537
42.8	24,094	96.8	6,273
44.6	22,946	98.6	6,021
46.4	21,859	100.4	5,781
48.2	20,829	102.2	5,551
50.0	19,854	104.0	5,332
51.8	18,930	105.8	5,123
53.6	18,054	107.6	4,923
55.4	17,223	109.4	4,732
57.2	16,436	111.2	4,549
59.0	15,689	113.0	4,374
60.8	14,980	114.8	4,207
62.6	14,306	116.6	4,047
64.4	13,667	118.4	3,894
66.2	13,060	120.2	3,748
68.0	12,483	122.0	3,608
69.8	11,935	123.8	3,473
71.6	11,414	125.6	3,345
73.4	10,919	127.4	3,222
75.2	10,447	129.2	3,104
77.0	9,999	131.0	2,991
78.8	9,572	132.8	2,882
80.6	9,166	134.6	2,778
82.4	8,779	136.4	2,679
84.2	8,411	138.2	2,583

### 1. 1K Ohm (1K Ω) Outdoor Temperature Sensor Kit - BD710487302V

- Use the Outdoor Sensor (OAS) Kit with Heating Only or Combi Boilers.
- Wire Control to boiler M2 terminal strip, terminals 4 and 5 as shown.
- Install/locate Control follow supplied instructions with sensor kit and Installation, Operation and Maintenance Manual (IOM).

#### Setting "Kt" Climate Curve:

1. Boiler automatically recognizes OAS sensor when wired to M2 terminal block. Display changes to show current default "Kt" value (80). Note display value.
2. When operating in CH mode, boiler setpoint is determined by the **Kt** value selected and actual outside air temperature. Refer to applicable °F (or °C) chart, (pg. 30) for setpoint information.
  - Select **Kt** range which will satisfy the desired boiler delivery temperature based on outdoor temperature range expected for your location. For example: if you need 176°F water when the outside temperature is 20°F and colder, select 35 for your **Kt** setting.
  - To change "default" **Kt** value on boiler control use or CH Heating buttons.
  - Restrict the upper limit of the **Kt** curve by using Parameter P16 to set the maximum boiler water temperature. P16 Default is 176°F.
3. When OAS is installed, pressing or buttons will no longer display boiler CH setpoint temperature. It now displays the **Kt** value which can range from 10 to 90.
4. When scrolling has stopped, boiler will automatically "SAVE" value as new **Kt** default value and automatically return to CH mode when no **Kt** adjustment activity is sensed. **Kt** values can be changed in +/- 1 point increments.
5. To return, to verify or change current **Kt** "default value, depress one of the CH setpoint adjustment buttons (once), or , while in any heating or standby mode. Adjust **Kt** value to obtain desired comfort level.

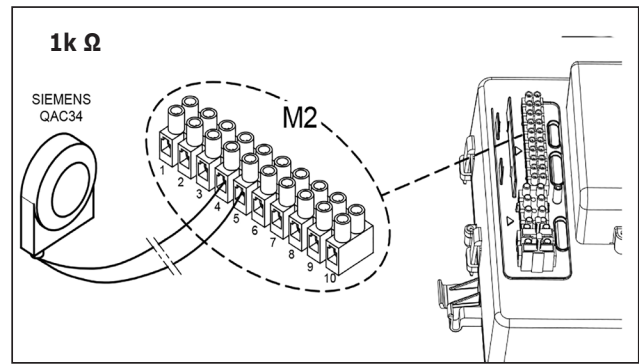

Boiler Control Panel

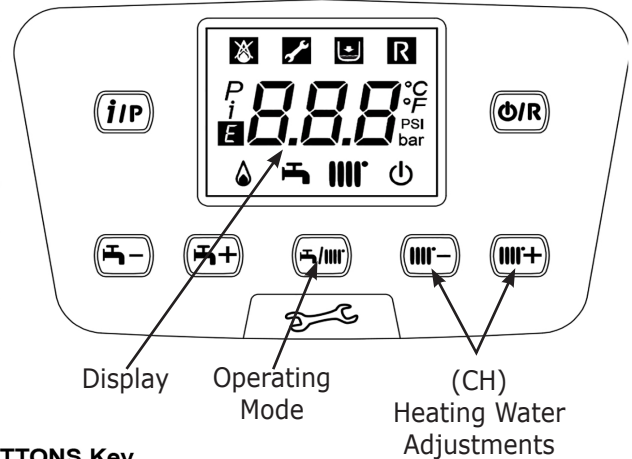

#### BUTTONS Key

	DHW temperature adjustment (+ to increase the temperature and - to decrease it)
	Heating water temperature adjustment (+ to increase the temperature and - to decrease it)
	Boiler operating information
	Operating mode: DHW – DHW & Heating – Heating Only
	Off – Reset – Exit menu/functions

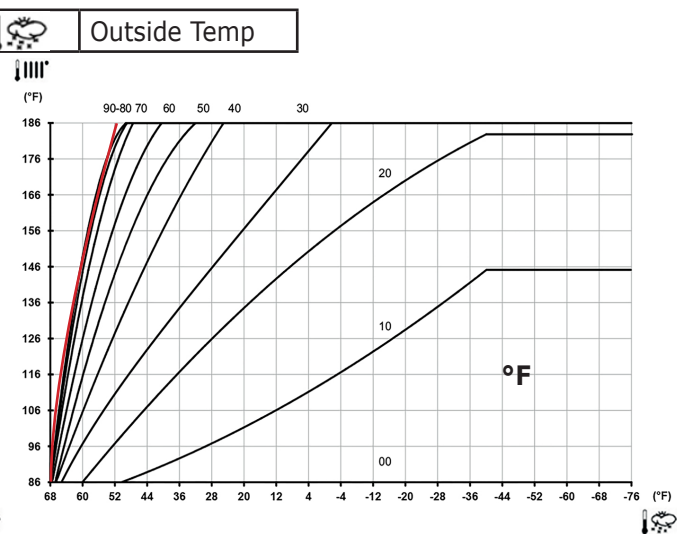
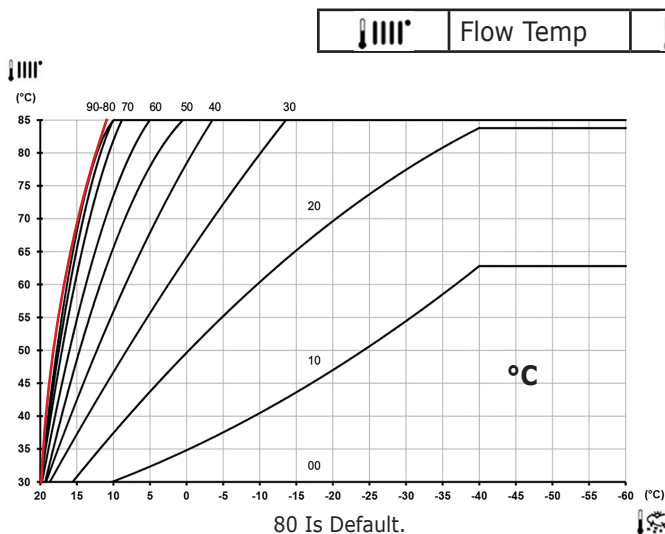

**Note** For temperatures below -40°F (-40°C), maximum heating flow temperature set point no longer increases and curves on the graph become horizontal. Boiler set point will override sensor setpoint.

## ACCESSORIES

### 2. 10k Ω Indirect Storage Tank Sensor Kit

Heating Only boiler can be electrically connected to Indirect Storage Tank.





Parameter PO3 for **Heating Only** boiler, with no indirect tank remains Factory Set at 08. No change is required.

Diagram of electrical connection of external indirect storage tank is shown below.

If adding an Indirect Tank with a sensor to **Heating Only Boiler** - change PO3 parameter from 08 to 05.

Connect DHW priority sensor to terminals 3 and 4 on terminal block M2. The element of the sensor must be inserted in the sensor well located on the indirect storage tank.

If adding an Indirect Tank with a thermostat to **Heating Only Boiler** - change PO3 parameter from 08 to 04.

Verify the exchange capacity of the indirect boiler tank coil is appropriate for power of the heating only boiler. Adjust DHW temperature (+95°F...+140°F / +35°C...+60°C) by pressing   buttons on boiler control panel.

See Section 9, Parameter Settings, in boiler's Installation, Operation, and Maintenance Manual.

Parameter PO3 for **COMBI** boiler factory set at 00 requires no change.

#### Electrical Connection Heating Only Boiler

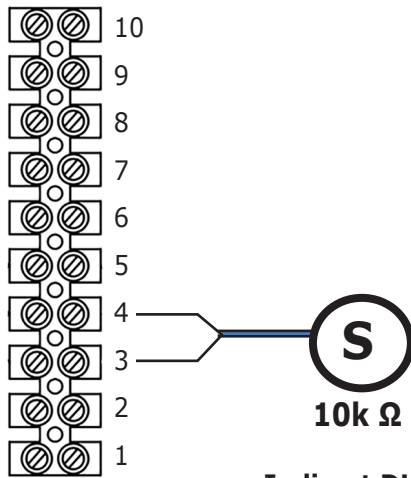

**M2**

**Indirect DHW Tank  
Sensor Wiring  
(100 & 125 MODELS)**

#### Electrical Connection Heating Only Boiler

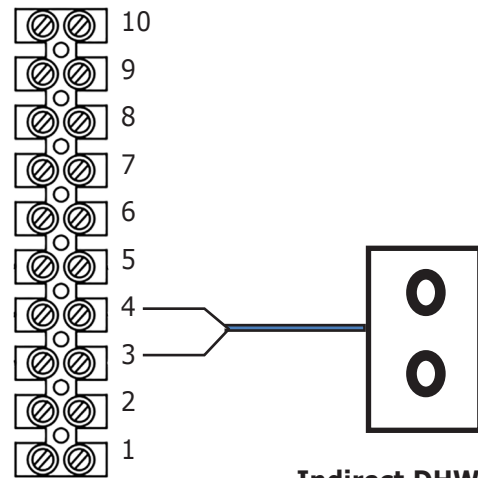

**M2**

**Indirect DHW Tank  
End Switch Wiring  
(100,125 & 165  
MODELS)**

#### Management of 0-10V Input

To activate the 0-10v function **parameter 82** must be set to **3**.

There must be at or above 3 V DC present for the control to recognize a call for heat.

When **P78 = 1** the 0-10v input manages CH heating setpoint directly per chart below.

When **P78 = 2** the 0-10v input manages CH heating input directly per chart below.

When **P78 = 0** Disabled

Voltage	P78=1		P78 = 2					
	Temp Setting		100/115		125/150		165/205	
	°C	°F	kW	MBH	kW	MBH	kW	MBH
0-3	OFF							
3	25	77	4.9	16.6	6.4	22.0	8.6	29.5
4	32	90	8.4	28.9	10.7	36.5	14.4	49.0
5	40	104	12.0	40.8	14.9	51.0	19.9	68.0
6	49	120	15.4	52.4	19.2	65.5	25.5	87.0
7	57	135	18.5	63.1	23.4	80.0	31.1	106.0
8	65	149	22.2	75.7	27.7	94.5	36.6	125.0
9	73	163	25.3	86.2	31.9	109.0	42.5	145.0
10	80	176	27.4	93.6	36.9	125.0	48.1	164.0

# CIRCULATOR CONNECTIONS - WIRING DIAGRAM

## Single Zone Circulator Wiring Using ARGO AR822-II

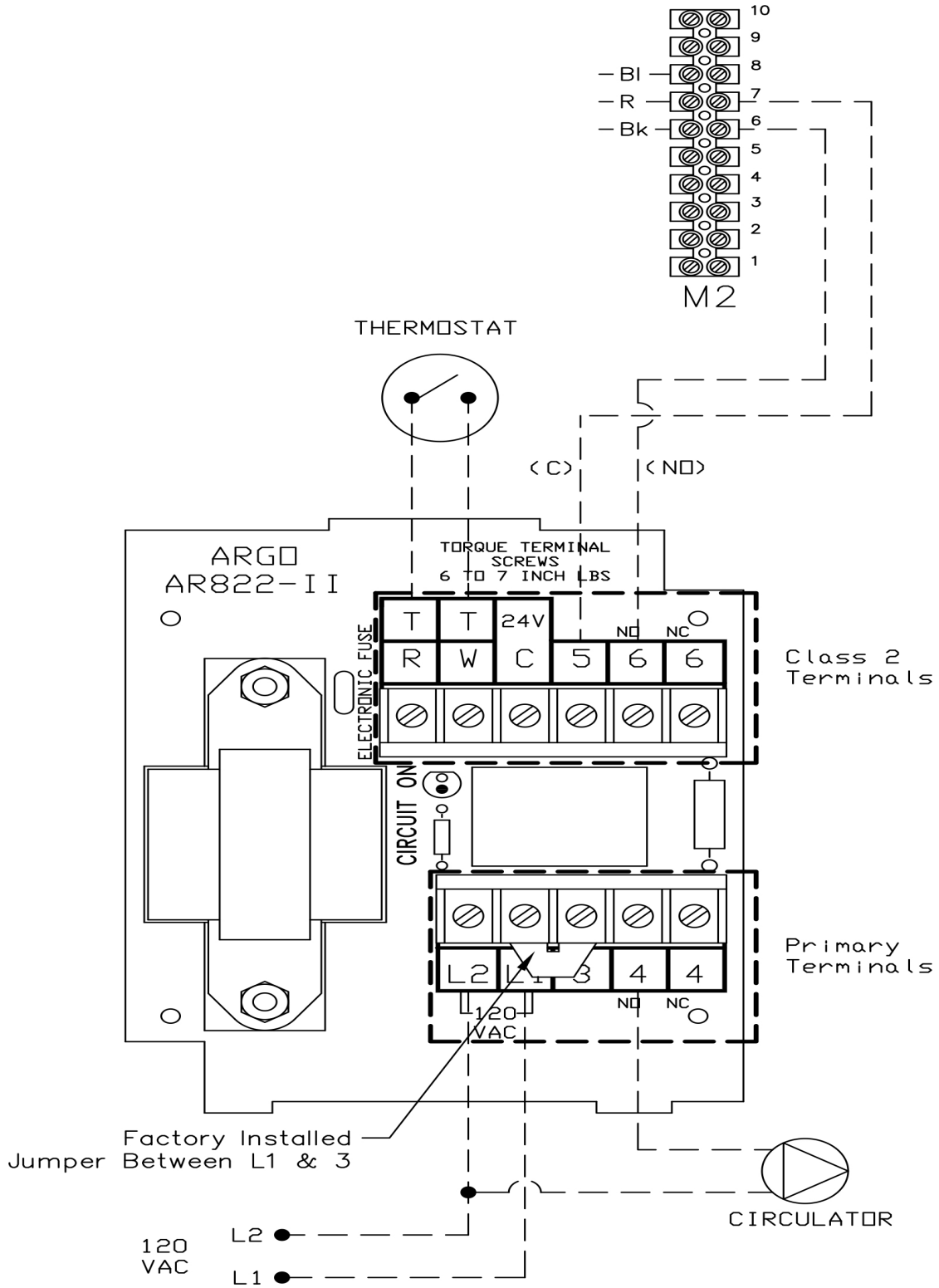



# 100 - HEAT ONLY WIRING DIAGRAM

## MODEL 100 - Heat Only

240013362 REV A

- LEGEND - LEGENDE:**
- 1-Fuses 3,15 A - Fusibles 3,15 A
  - 2-Supply 120V - 60Hz - Alimentation
  - 4-Fan - Ventilator
  - 5-Safety Thermostat - Thermostat de Sécurité
  - 6-Gas valve - Vanne a gaz
  - 7-Exchanger sensor - Sonde échangeur
  - 8-Water Pressure sensor - Pressostat Eau
  - 9-NTC return sensor - Sonde NTC retour
  - 10-NTC flow sensor - Sonde NTC départ
  - 11-Remote User Interface or Open Therm
  - 12-Prov. for Outside Sensor - Pred. Sonde Extérieure
  - 13-Link 24V - Joint 24V
  - 14-Flame Sensing Electrode - Electrode présence veilleuse
  - 15-Ignition Electrode - Electrode d'allumage
  - 16-Three Way Valve - Soupape Trois Voies
  - 17-Pump - Pompe
  - 18-Flue Safety Thermostat - Thermostat Fumées
  - 19-Link 0 - 10V - Joint 0 - 10V
  - 20-Condensate sensor - Capteur de condensation
- M1 - Main Power Terminal Board - Bornier d'alimentation  
M2 - Accessories Terminal Board - Bornier pour accessoires

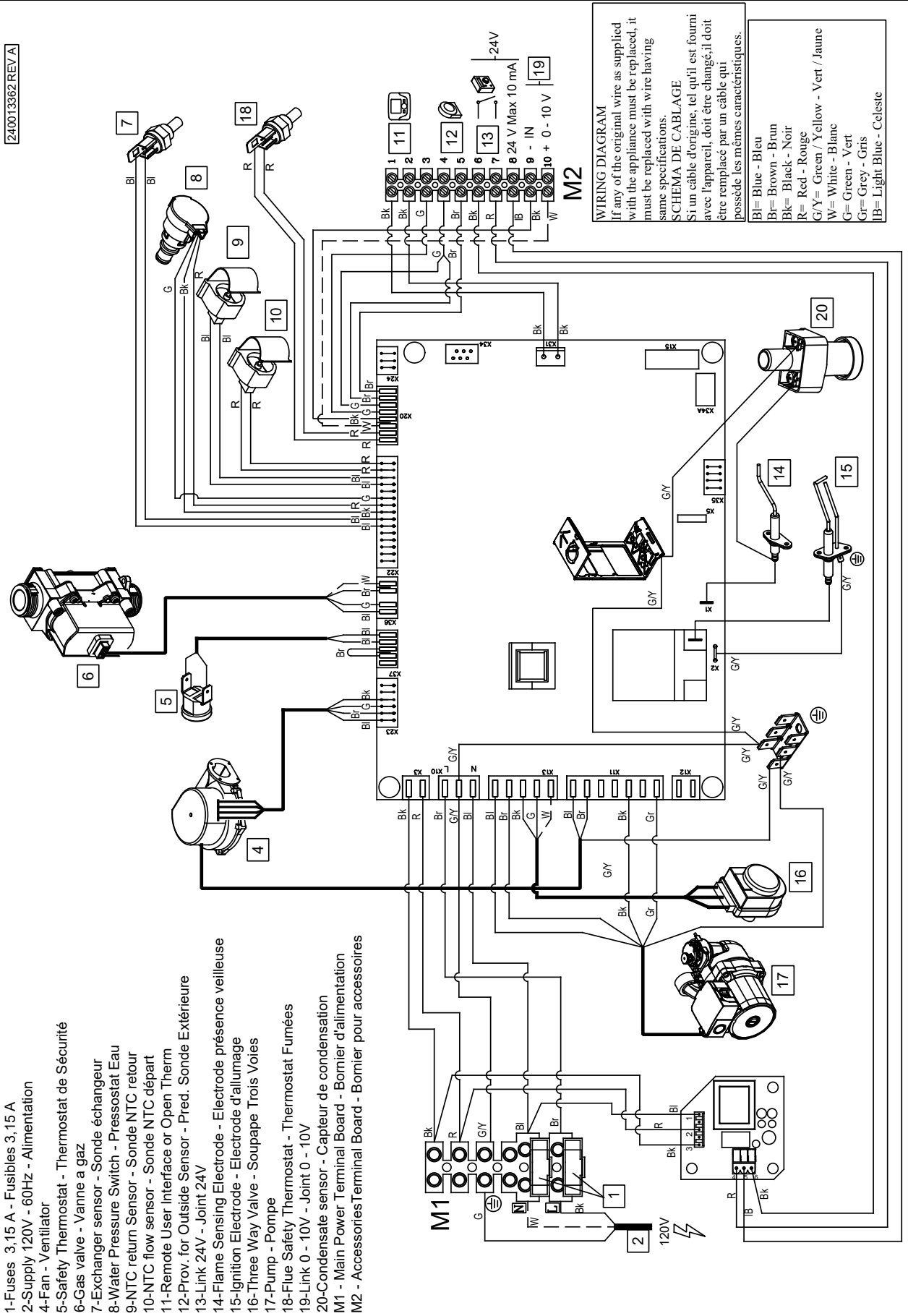

**WIRING DIAGRAM**  
If any of the original wire as supplied with the appliance must be replaced, it must be replaced with wire having same specifications.  
**SCHEMA DE CABLAGE**  
Si un câble d'origine, tel qu'il est fourni avec l'appareil, doit être changé, il doit être remplacé par un câble qui possède les mêmes caractéristiques.

Bl= Blue - Bleu  
Br= Brown - Brun  
Bk= Black - Noir  
R= Red - Rouge  
G/Y= Green / Yellow - Vert / Jaune  
W= White - Blanc  
G= Green - Vert  
Gr= Grey - Gris  
LB= Light Blue - Celeste

# 125 - HEAT ONLY WIRING DIAGRAM

## MODEL 125 - Heat Only

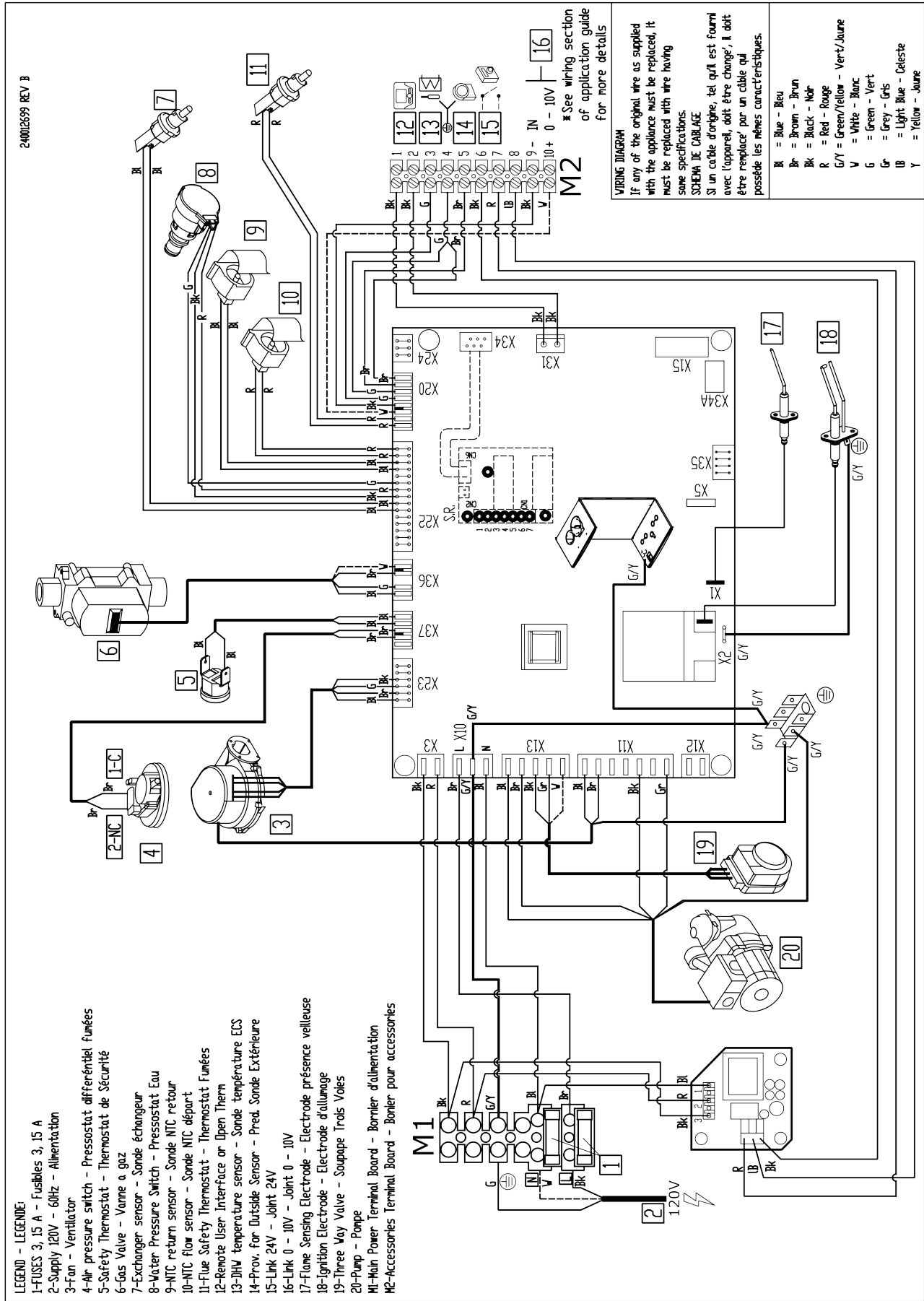

# 165 - HEAT ONLY WIRING DIAGRAM

## MODEL 165 - Heat Only

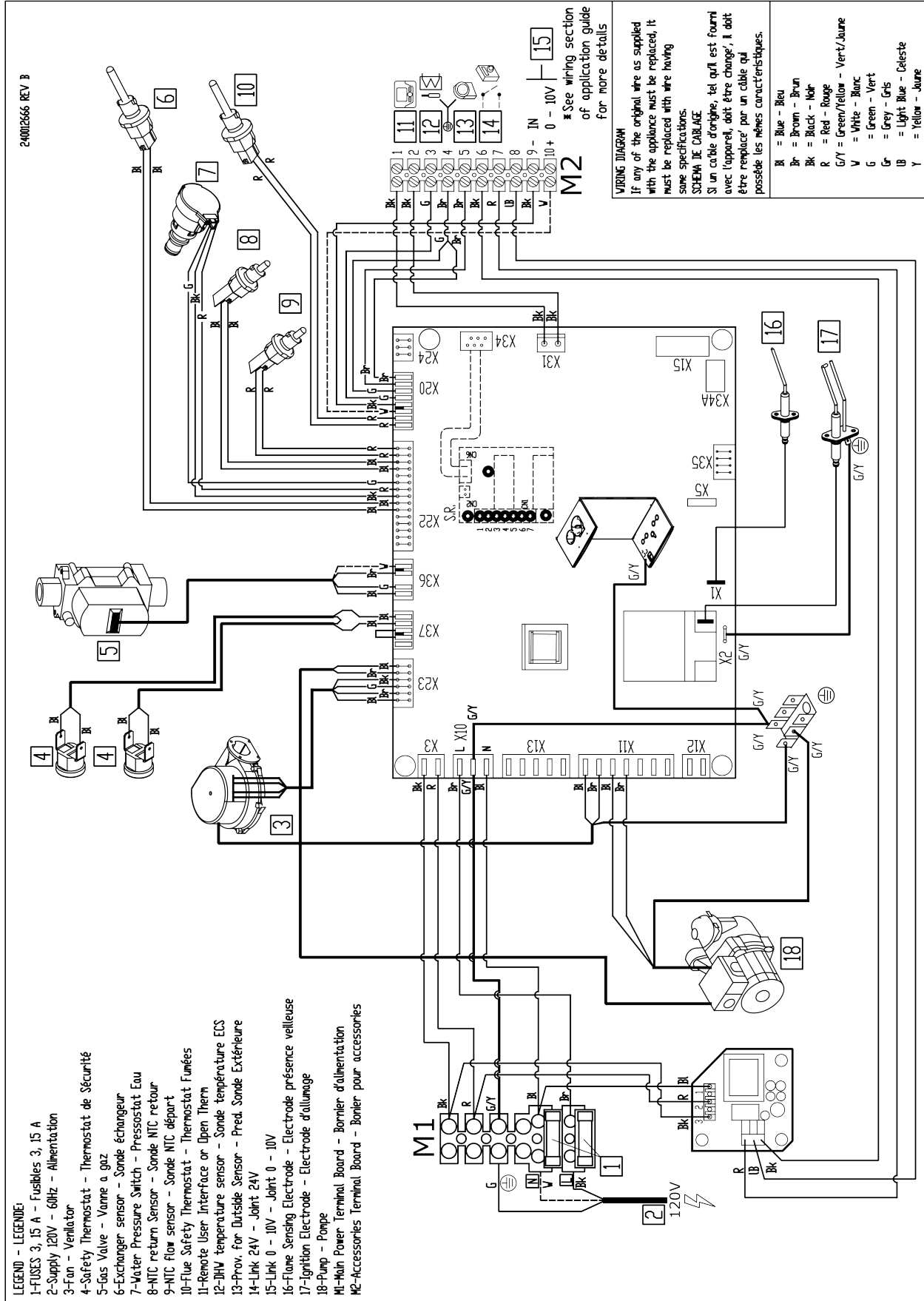





# 205 - COMBI WIRING DIAGRAM

## MODEL 205 - Combi

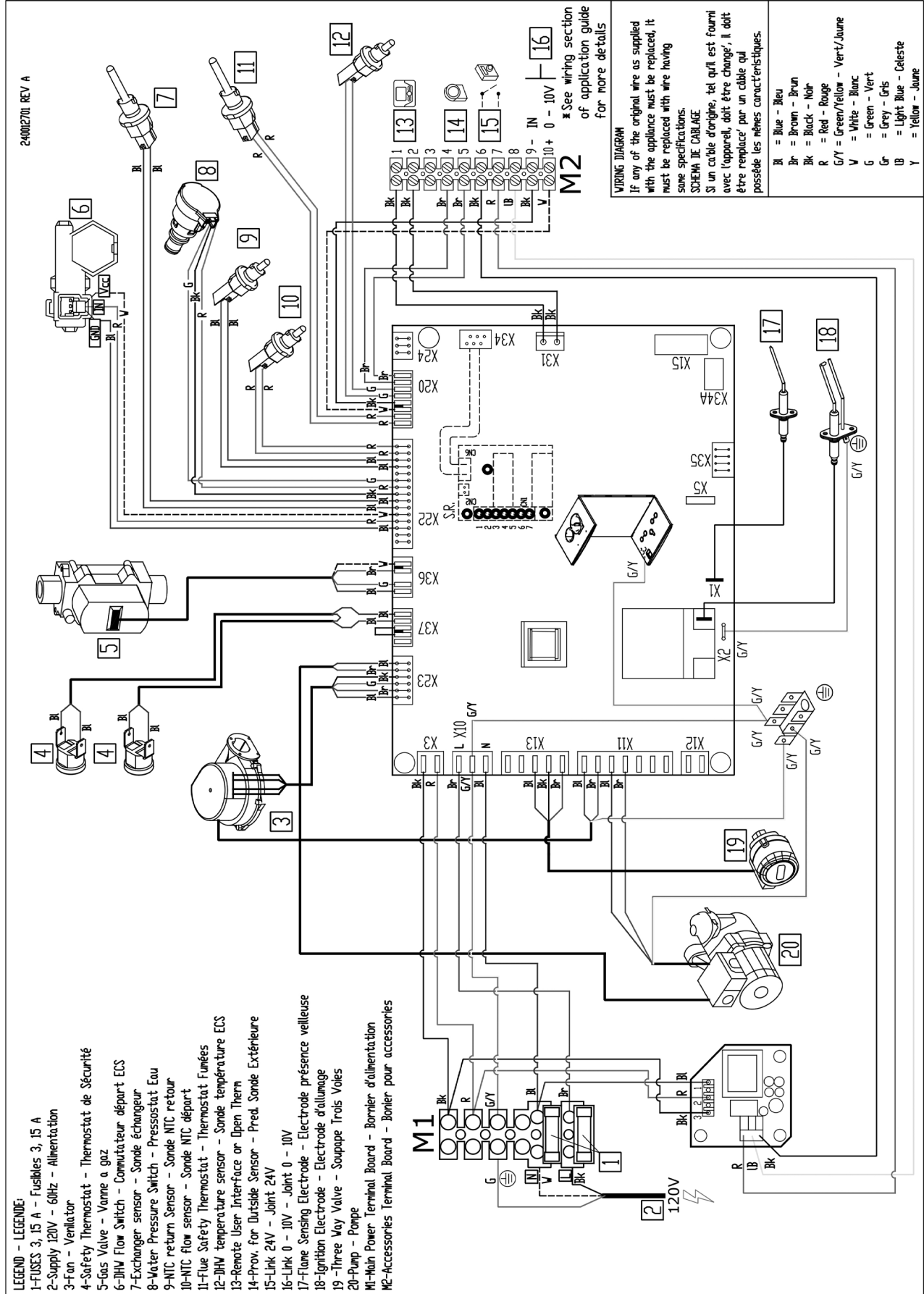

# ALTITUDE EFFECTS ON BOILER PERFORMANCE

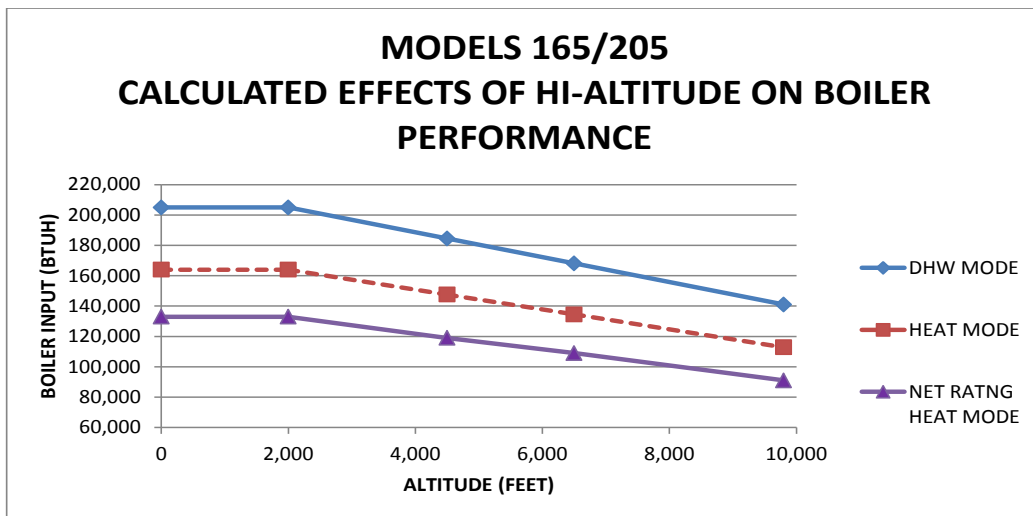
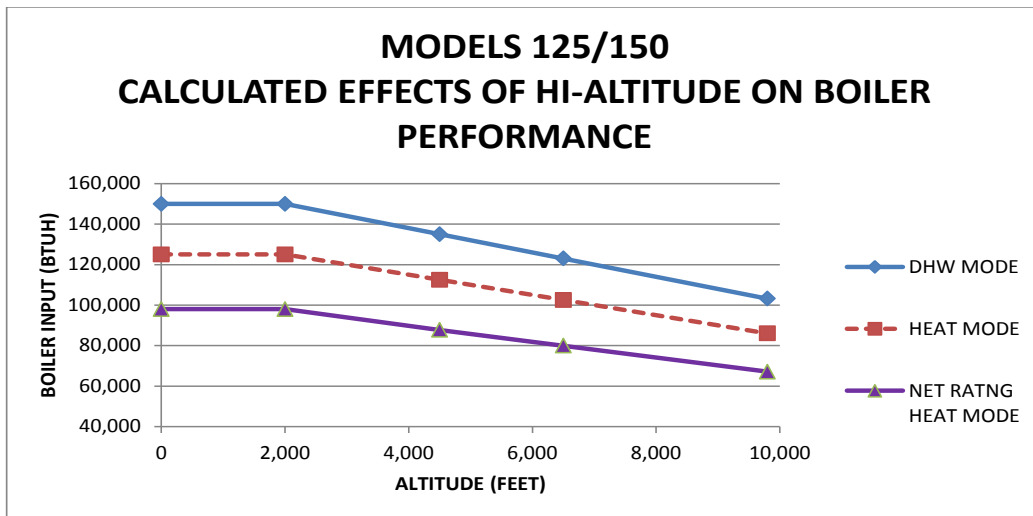
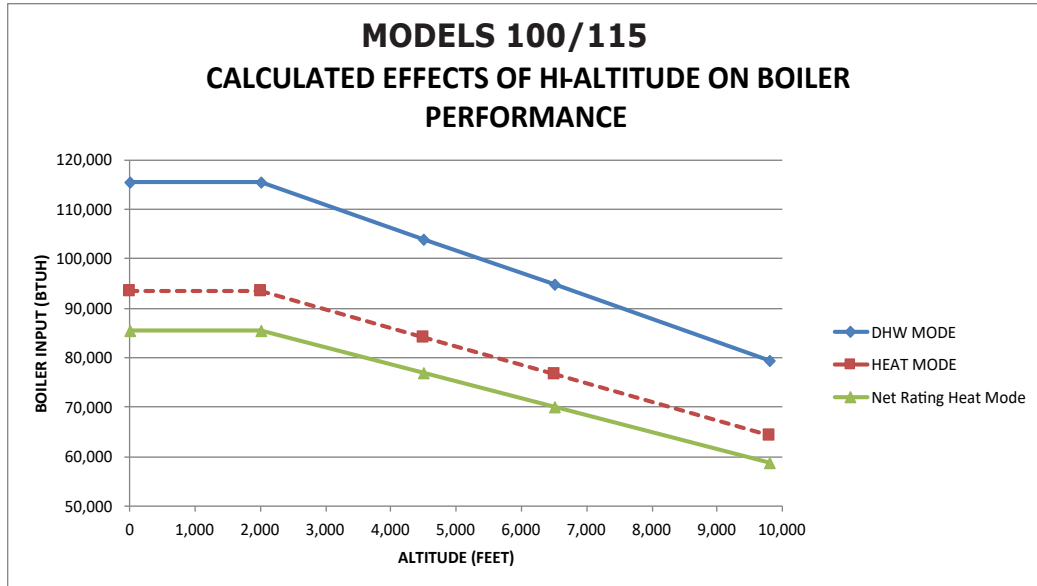

**APPLICATION TABLE - INDIRECT HOT WATER TANK PERFORMANCE CHART**

**HEATING ONLY BOILERS 100, 125, 165**

Model	Max. First Hour Rating		Continuous Rating		BOILER OUTPUT NEEDED FOR MAXIMUM PERFORMANCE  (BTU/Hr)	Boiler Water Flow Through Coil  Gal/Min	Pressure Drop Through Coil  (Ft. Water)
	Gal/Hr. @		Gal/Hr @				
	140 F	115 F	140 F	115 F			
H2OI30	176	233	149	206	112,000	14.0	5.7
H2OI40	193	254	157	218	118,000	14.0	5.9
H2OI40L	186	251	150	215	116,000	14.0	5.6
H2OI50	196	254	151	231	125,000	14.0	6.2
H2OI60	231	298	177	244	132,000	14.0	6.4
H2OI60L	211	272	157	218	118,000	14.0	5.9
H2OI80	241	306	169	234	127,000	14.0	6.2
H2OI115	291	363	188	260	141,000	14.0	6.7
<b>High Output Units 60HO, 80HO, and 115HO</b>							
H2OI60HO	353	468	299	414	221,000	14.0	10.5
H2OI80HO	366	479	294	407	220,000	14.0	10.3
H2OI80HOC	386	507	314	435	236,000	21.0	15.8
H2OI15HO	413	532	310	429	232,000	14.0	10.8
H2OI115HOC	423	545	320	442	240,000	21.0	16.7
<b>Extra High Output Units 85XHO and 115XHO</b>							
H2OI85XHOC	649	868	571	790	428,000	28.0	13.0
H2OI115XHOC	674	893	571	790	428,000	28.0	13.0

**Notes:**

**176 °F Boiler Supply Water Temperature, AHRI Conditions -50 °F Inlet Water @ 240 GPH Flow Rate.**



## LOW WATER CUTOFF

### Low Water Cut Off - Heating Only and Combi Boilers

These guidelines are supplied when necessary to install an additional Low Water Cut Off (LWCO), for sensing a low water level condition in a boiler, as required by the Authority Having Jurisdiction.

Follow LWCO manufacturer installation instructions for type of LWCO selected in addition to these instructions.

LWCO shall be 120V/60HZ control and dry contacts sized for load being connected. Wire control to boiler. See Figure below.

Connect LWCO device to the system ground. Ground Boiler in accordance with the requirements of the authority having jurisdiction or, in the absence of such requirements, with the National Electrical Code (NEC) or Canadian Electrical Code CEC.

- Locate LWCO sensing device in the supply piping, above the minimum height of boiler. See Figure page 42, Piping Diagram.
- Position control in piping above boiler to assure proper boiler protection.
- For proper operation, sensing element of the LWCO control shall be positioned in the tee to sense the main water stream. Maintain minimum 1/4" spacing from pipe walls. Element shall NOT contact the rear, or side walls of the tee. See Figure page 43.
- Install an air vent using a tee to avoid nuisance shutdowns.
- Apply small amount of pipe sealant to threaded connections.
- Arrange piping to prevent water dripping onto boiler.
- DO NOT install water shutoff valve between boiler and LWCO sensing device.

### LWCO Wiring Diagram

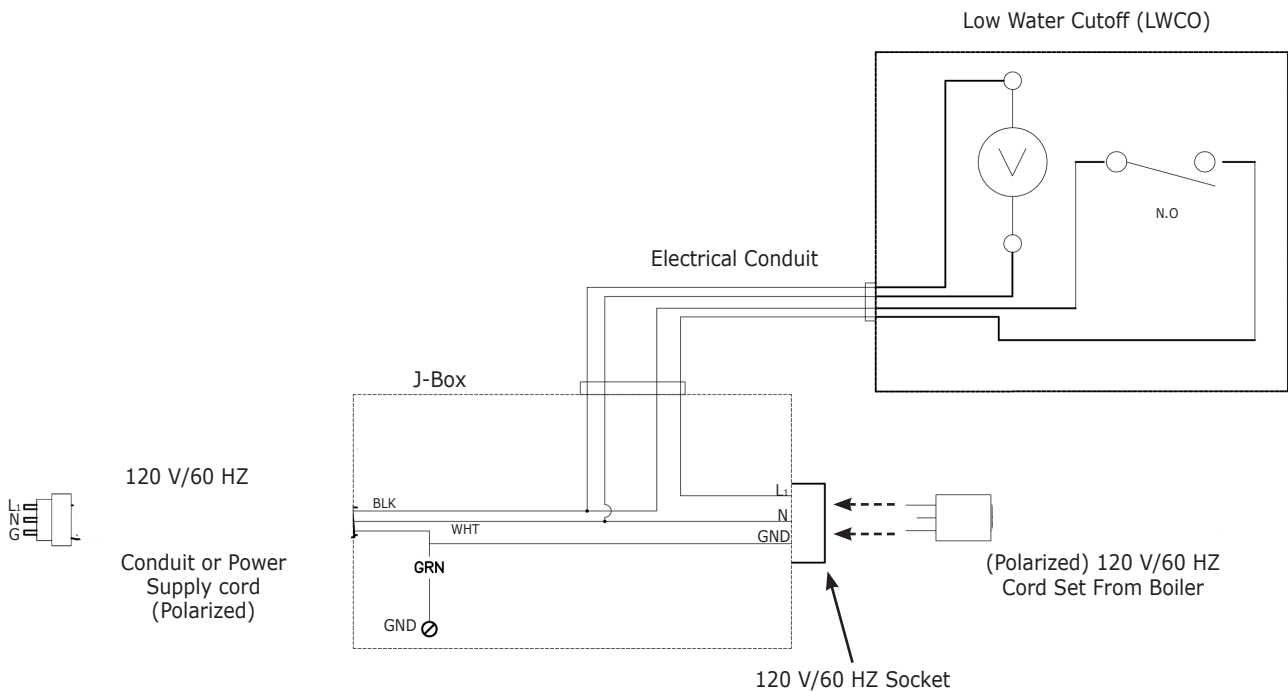

# LOW WATER CUTOFF

## Piping Diagram - LWCO Location

**Note** Arrange piping to prevent water dripping onto boiler.

**Note** Illustrations are meant to show system piping concept only. Installer is responsible for all equipment and detailing required by authority having jurisdiction.

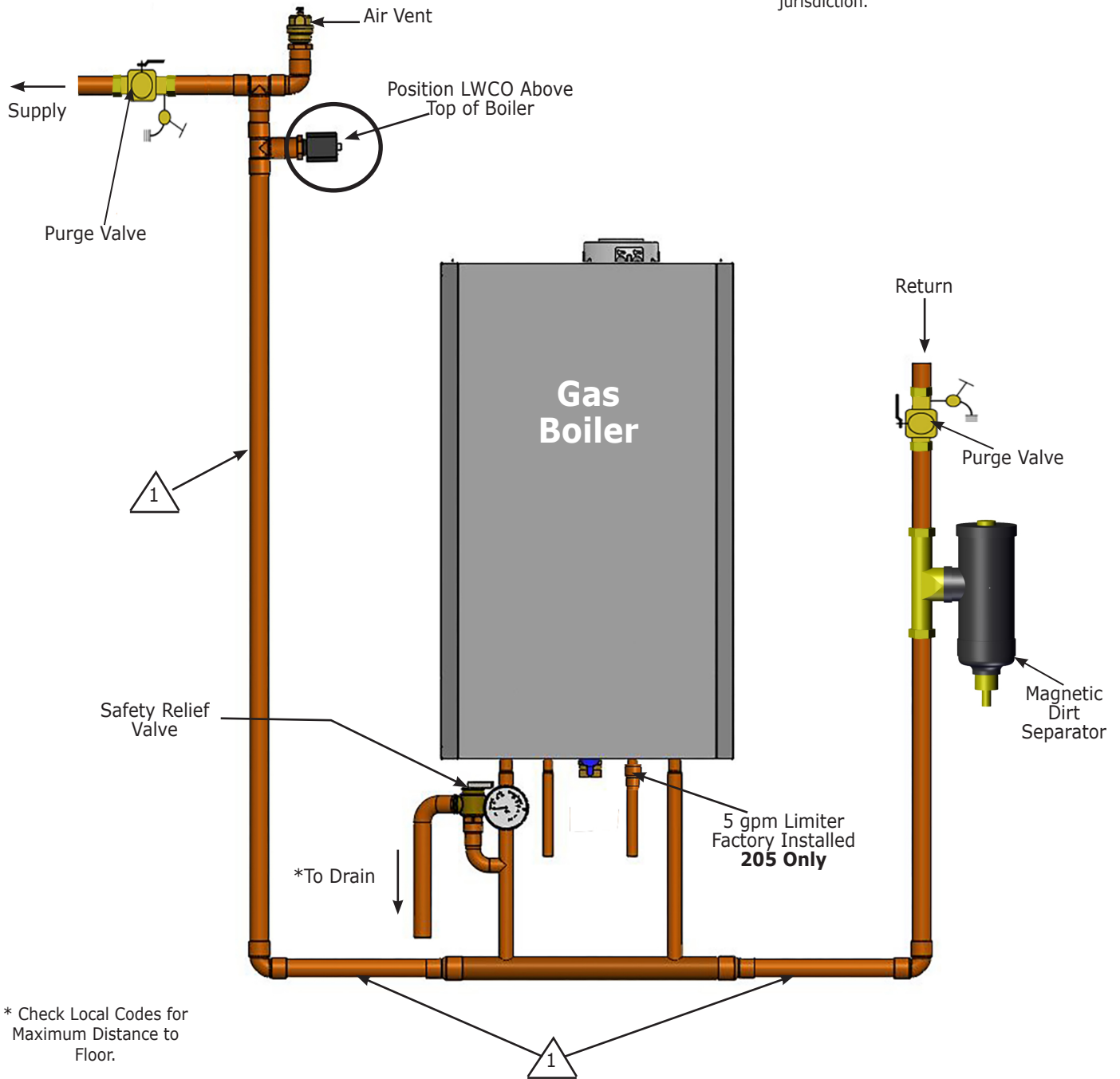

\* Check Local Codes for Maximum Distance to Floor.

**Note** **1** DO NOT PLACE ISOLATION VALVE BEFORE TEE OR LWCO.

# LOW WATER CUTOFF

## Low Water Cutoff - Detail

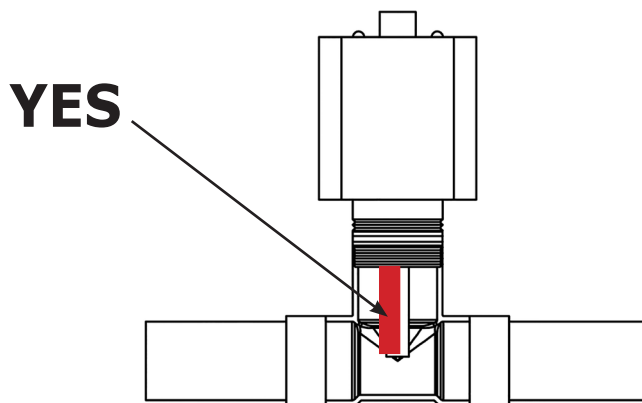
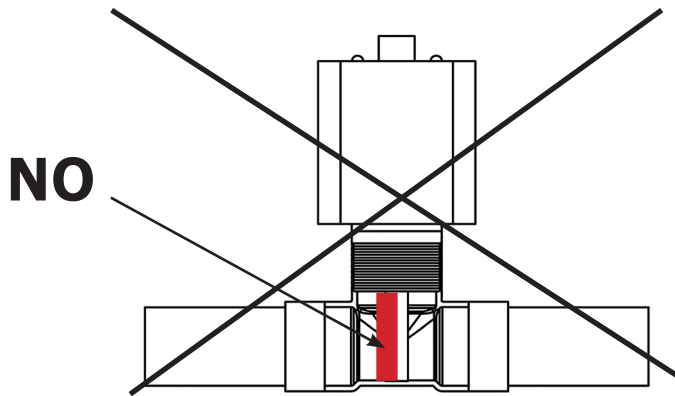
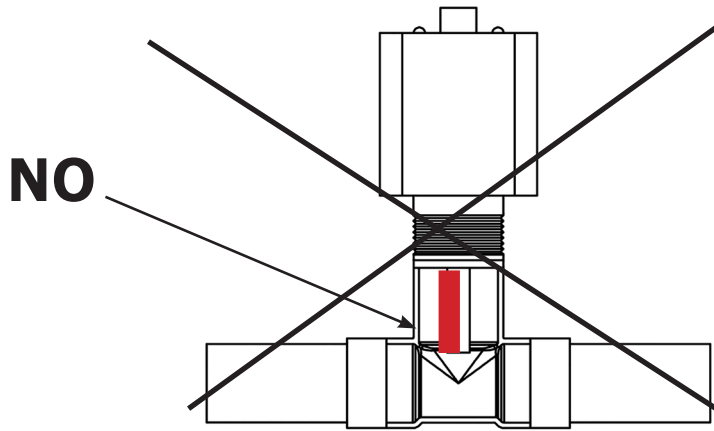

## ERROR CODE TABLE

**Note:** When instructed press and hold "RESET" for between 1-3 seconds to reset the boiler.

### Table of Error Codes

<b>E</b> 09	Gas Valve Connection Cable
<b>E</b> 10	External Probe Fault
<b>E</b> 12	Water Flow Switch Open
<b>E</b> 13	Water Flow Switch Close
<b>E</b> 15	Gas Valve Fault
<b>E</b> 18	Water Refill Enabled
<b>E</b> 19	Max Time Of Water Refill
<b>E</b> 20	Central Heating Flow NTC Fault
<b>E</b> 28	Flue NTC Fault
<b>E</b> 40	Central Heating Return NTC Fault
<b>E</b> 50	Hot Water NTC Fault (tank version)
<b>E</b> 53	Obstruction on flue pipe-combustion off
<b>E</b> 55	PCB to be set by the "Calibration Function"
<b>E</b> 71	Fan parameter Out of range in auto calibration
<b>E</b> 72	Combustion test out of range in auto calibration
<b>E</b> 77	Current Out of range
<b>E</b> 78	Minimum gas valve current
<b>E</b> 79	Maximum gas valve current
<b>E</b> 83-87	Communication error
<b>E</b> 92	Combustion test alarm during auto-setting
<b>E</b> 109	Pre-Circulation Fault
<b>E</b> 110	Safety Thermostat Operated
<b>E</b> 117	System Water Pressure To High
<b>E</b> 118	System Water Pressure To Low
<b>E</b> 125	Circulation Fault (Primary Circuit)
<b>E</b> 128	Flame Failure
<b>E</b> 129	Frequent loss of flame during ignition
<b>E</b> 130	Flue NTC Operated
<b>E</b> 133	Interruption of Gas Supply or Flame Failure
<b>E</b> 134	Elapsed time Gas valve open without gas
<b>E</b> 135	Interruption of gas supply (internal error)
<b>E</b> 160	Fan or Fan Wiring Fault
<b>E</b> 321	Domestic Hot Water NTC sensor fault
<b>E</b> 384	False flame
<b>E</b> 385	Under voltage

### Initial Fault Finding Checks

- 1 Check gas, water and electrical supplies are available at the boiler.
- 2 Electrical supply = 120V ~60 HZ
- 3 The preferred minimum gas pressure is 3.5" wc for Natural gas and 10" for LPG
- 4 Perform electrical system checks, i.e. Ground Continuity, Resistance to Ground, Short Circuit and Polarity with a suitable meter.

**NOTE: These checks must be repeated after any servicing or fault finding.**

- 5 Ensure all external controls are calling for heat and check all external and internal fuses. Before any servicing or replacement of parts, ensure the gas and electrical supplies are isolated.

- 1 If a fault occurs on the boiler an error code may show on the facia display:

**E** 20, **E** 28, **E** 40, **E** 50, **E** 160, **E** 321, and **E** 431 - Indicate possible faulty components.

**E** 53 - Indicates possible obstruction in the flue duct.

**E** 55 - Indicates the PCB is not setting/calibrated.

**E** 71, **E** 72, **E** 78 and **E** 92 - Indicates possible wrong calibration, a new calibration is needed.

**E** 92 - Indicates possible flue recirculation in the flue duct.

**E** 83.....87 - Shows possible error of communication with thermostat. (Go to section P, page 47)

**E** 110 - Shows overheat of primary.

**E** 117 - is displayed when the primary water pressure is more than 43 psi.

**E** 118 - is displayed when the primary water pressure is less than 7.25 psi.

**E** 125 - is displayed in either of two (2) situations:

a) If within a time between 15...30 seconds of the burner lighting the boiler temperature has not changed by 2°F.

b) If within 10 minutes of the burner lighting the boiler temperature twice exceeds the selected temperature by 80°F.

In these instances poor primary circulation is indicated.

**E** 128 - is displayed if there has been a flame failure during normal burner operation.

**E** 133, **E** 134, **E** 135 - Indicate the gas supply has been interrupted, ignition has failed or flame has not been detected.

- 2 Pressing the 'RESET' button for 1-3 seconds when: **E** 110, **E** 125, **E** 133, **E** 134, **E** 135, **E** 09, **E** 15, **E** 128 and **E** 384 - are displayed it is possible to relight the boiler.

- 3 If this does not have an effect, or error codes are displayed regularly further investigation is required.

# TROUBLESHOOTING CHART

## Central Heating

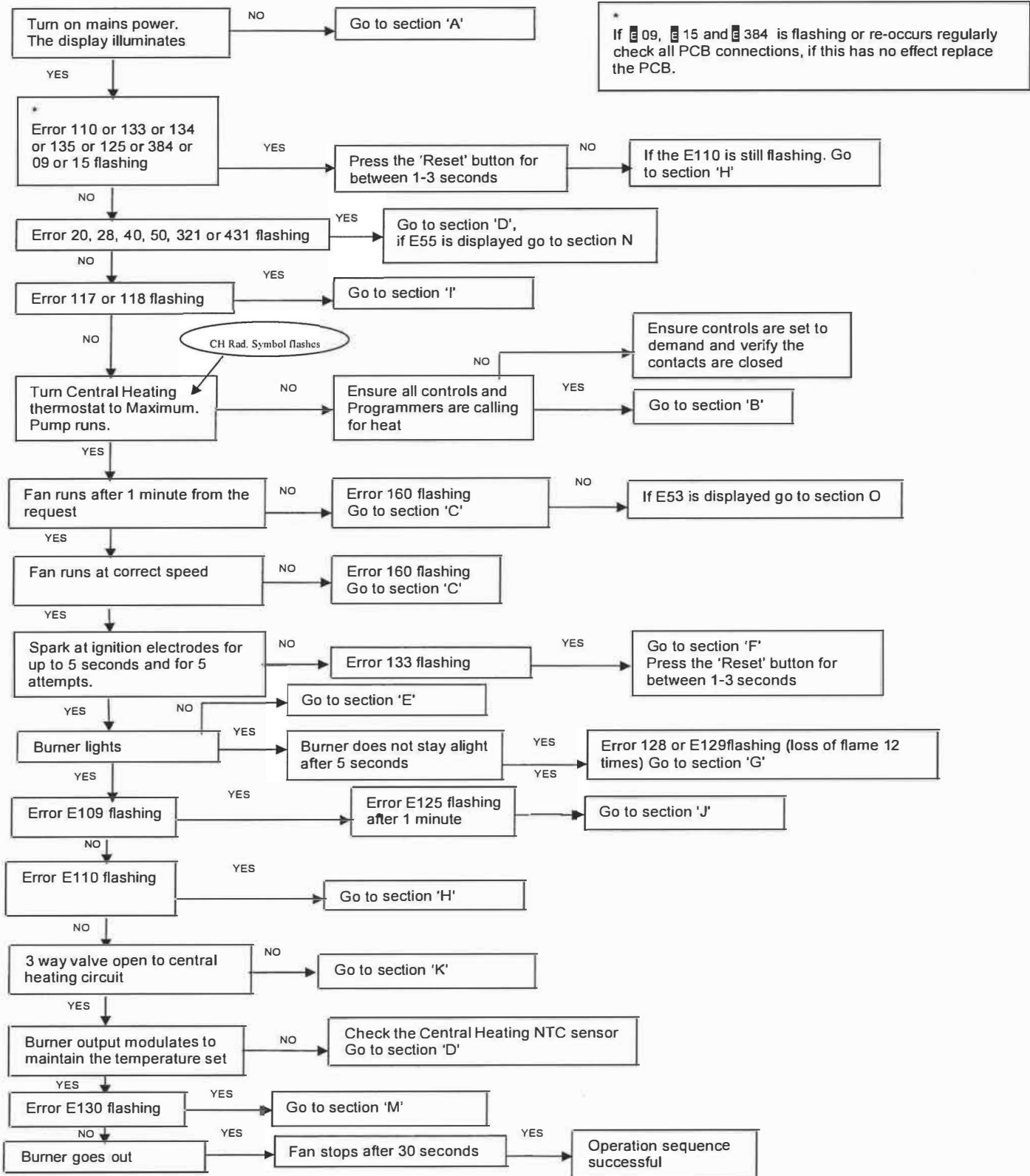

# TROUBLESHOOTING CHART

## domestic hot water

\* If 09, 15 and 384 is flashing or re-occurs regularly check all PCB connections, if this has no effect replace the PCB.

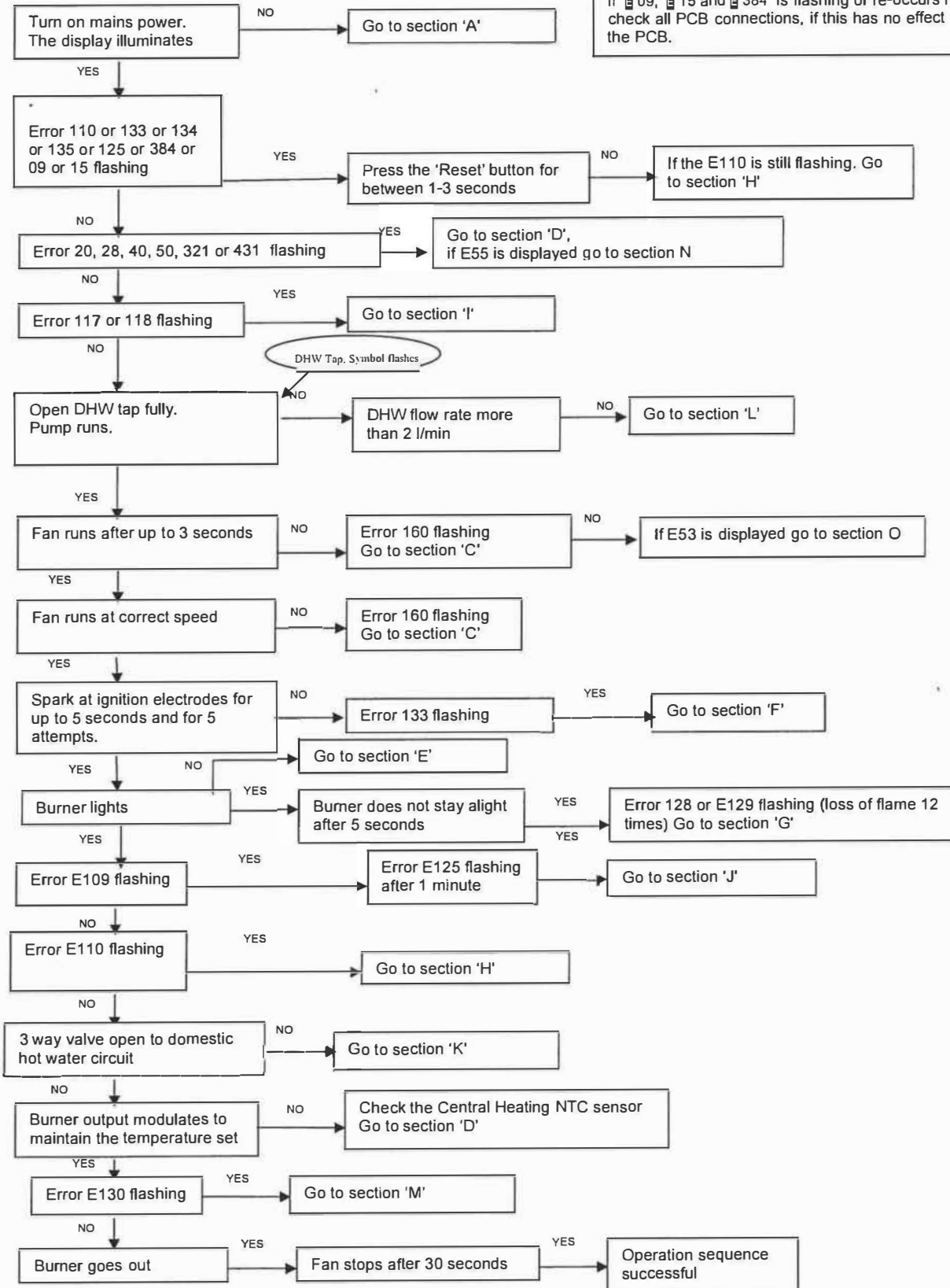

# FAULT SOLUTION SECTIONS

## Fault Finding Solutions Sections

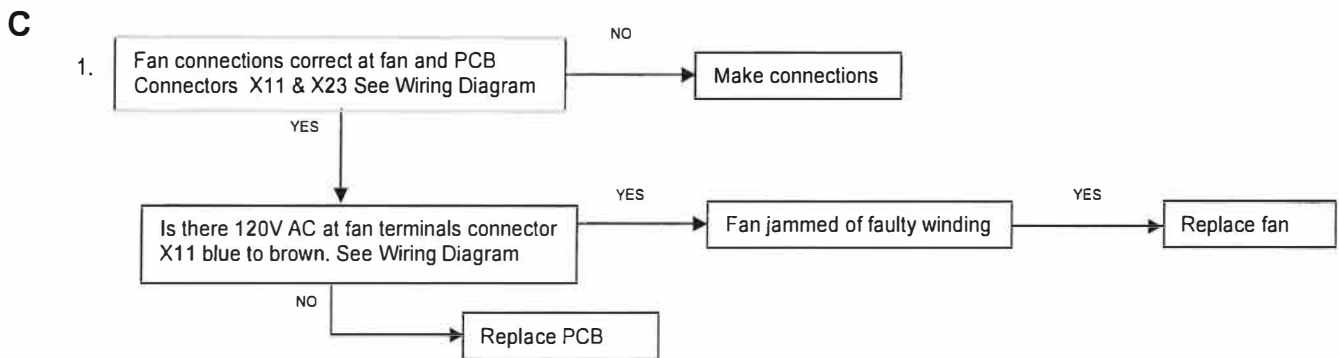
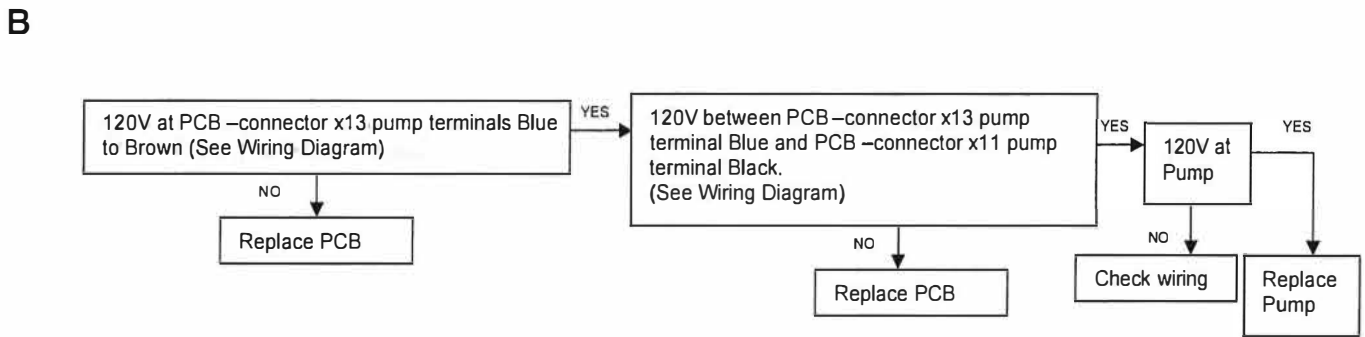
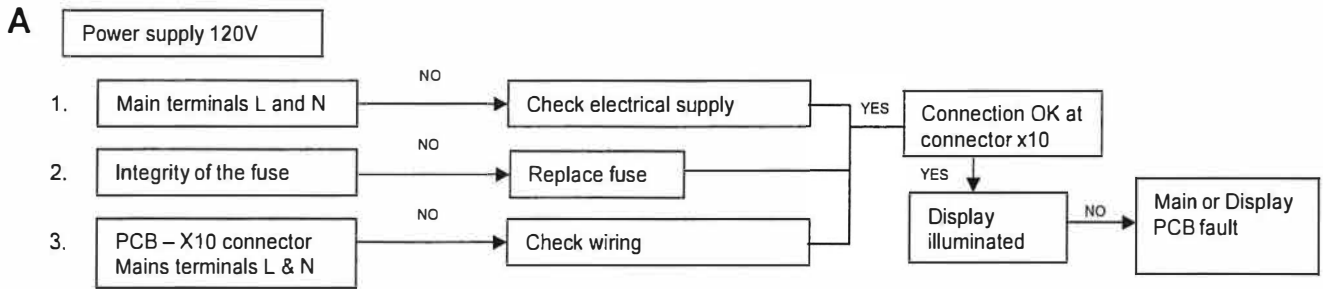

## FAULT SOLUTION SECTIONS

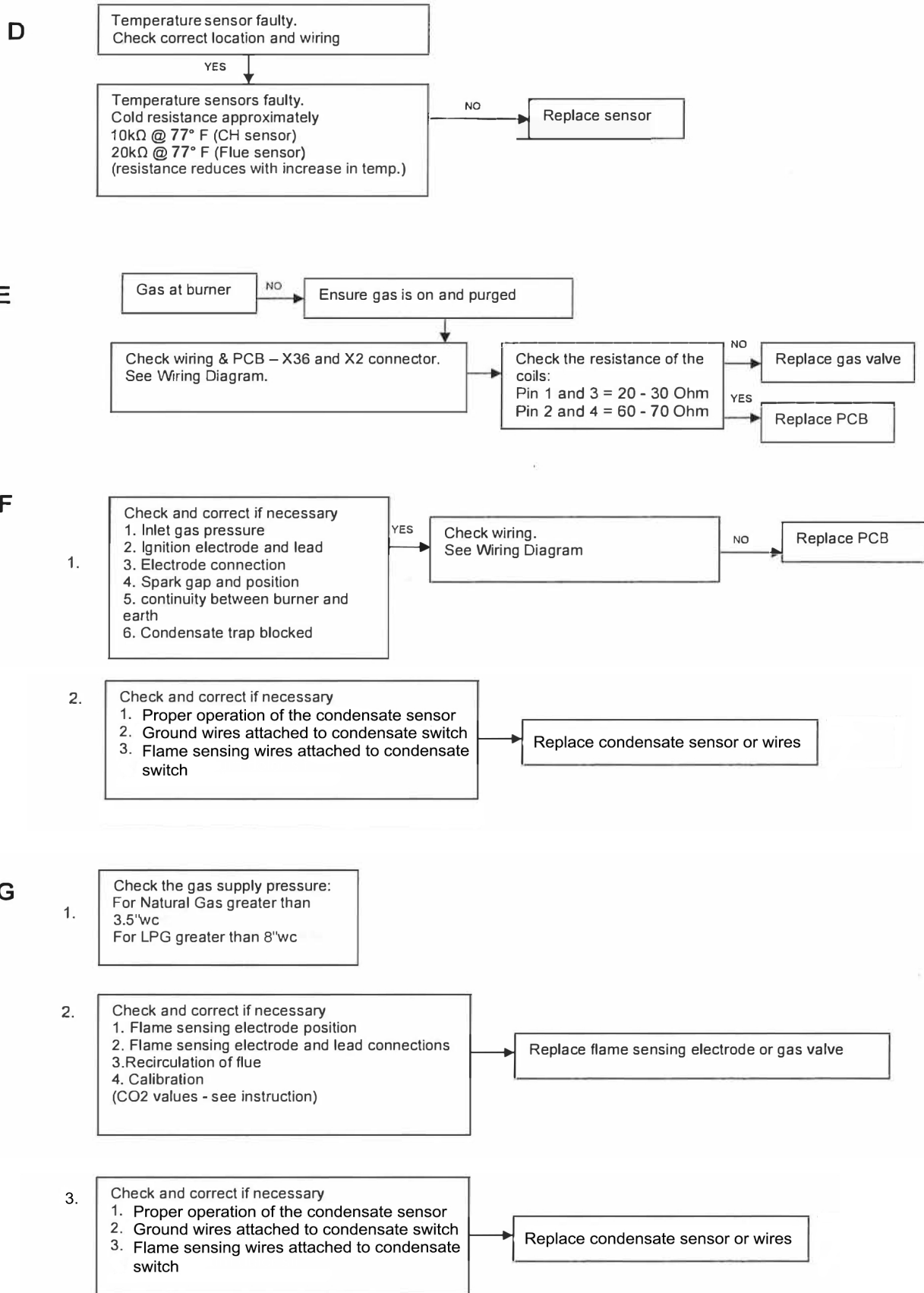



## FAULT SOLUTION SECTIONS

**H**

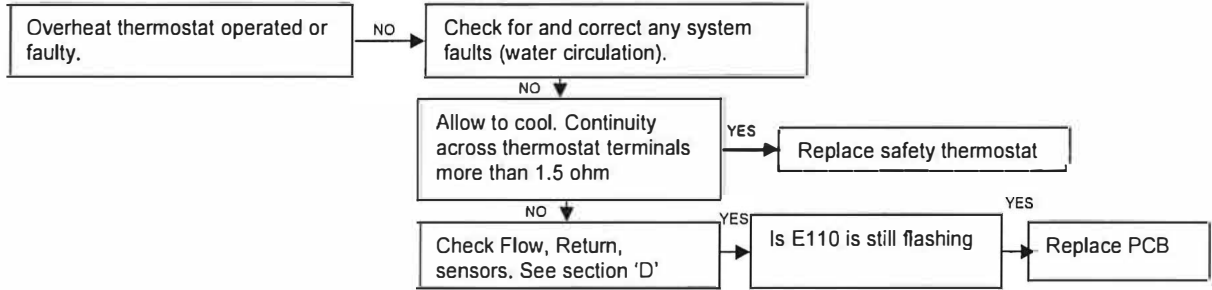

**I**

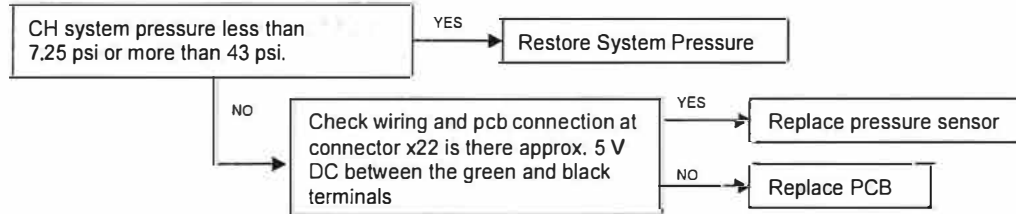

**J**

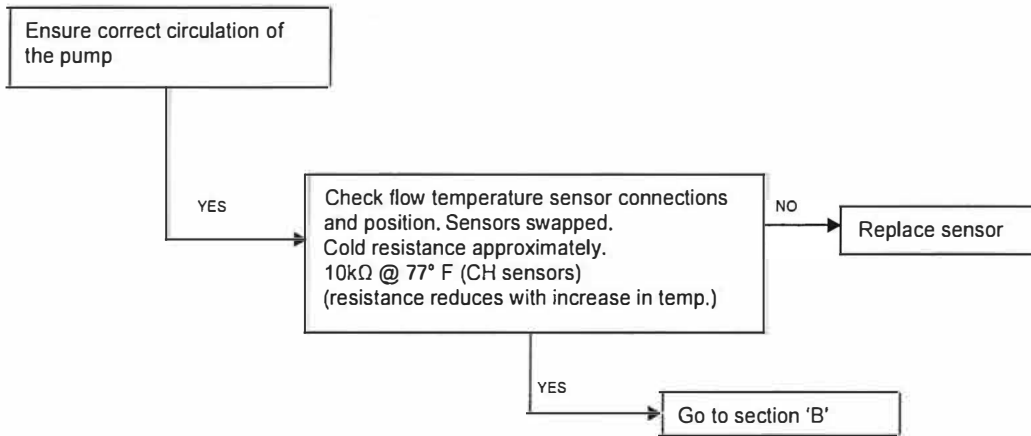

**K**

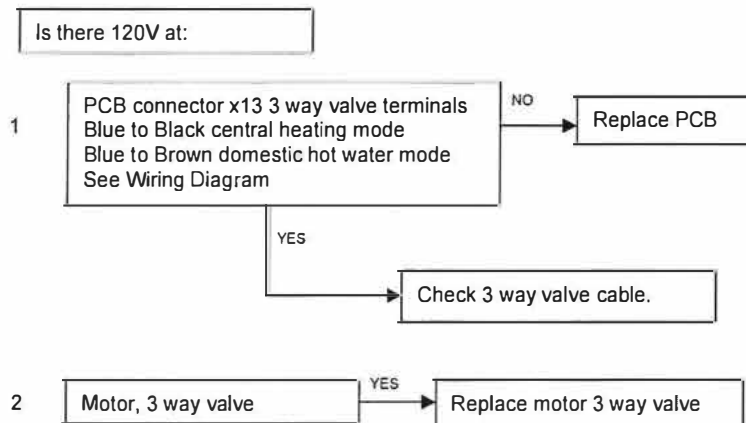

## FAULT SOLUTION SECTIONS

**L**

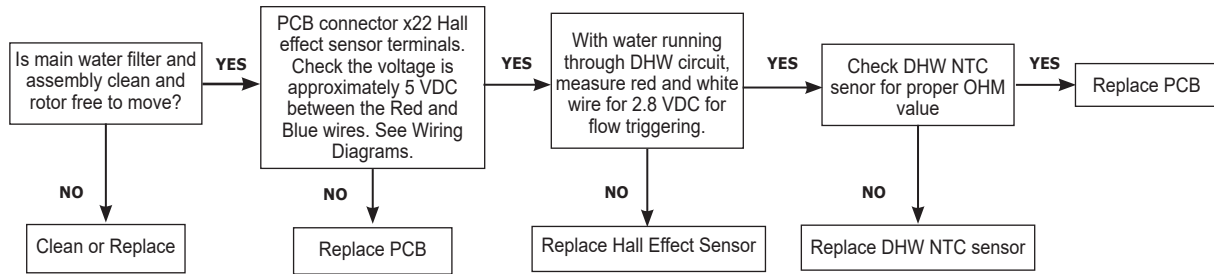

**M**

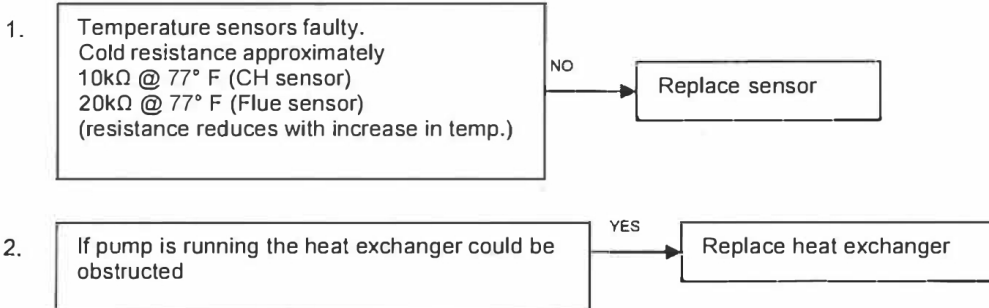

**N**

Performs the autocalibration function (see the Service manual)

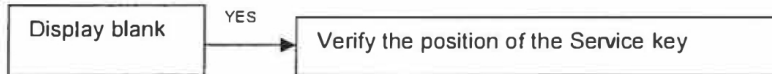

**O**

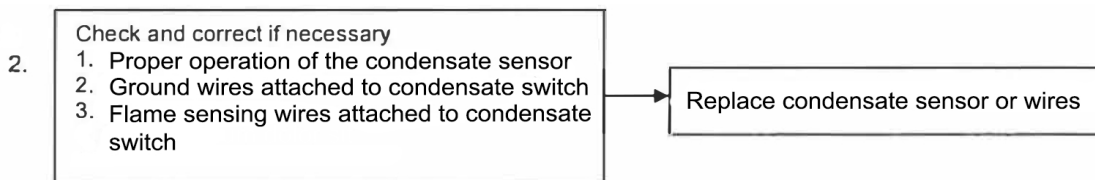
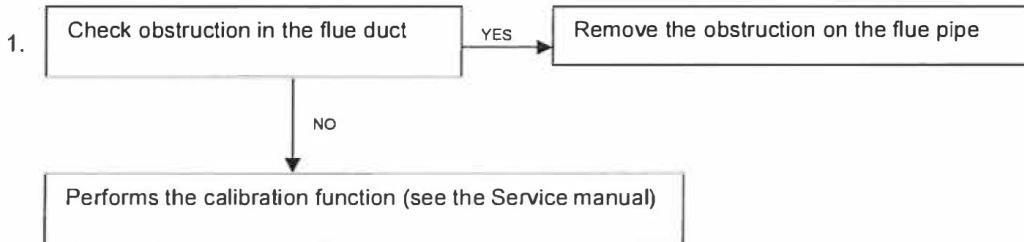

**P**

Check the electrical connection between Ru and pcb





2201 Dwyer Avenue, Utica, NY 13501  
Tel. 800 325 5479  
[www.ecrinternational.com](http://www.ecrinternational.com)

All specifications subject to change without notice.  
©2021 ECR International, Inc.