

**APPLICATION GUIDE
FOR USE WITH
HEATING ONLY - 125, 165
&
COMBI - 115, 150, 205**

This manual has been prepared for use with the appropriate Installation, Operation and Maintenance Manual.



Manufactured by:
ECR International Inc.
2201 Dwyer Avenue, Utica, NY 13501
Tel. 800 325 5479
www.ecrinternational.com
PN 240011430 REV. N [10/31/2020]

TABLE OF CONTENTS

Important Safety Information	3
Labor Saving Piping Manifolds / Near Boiler Piping Connections	4
General Information - Hydronic Piping	6
General Information - Wiring	8
Piping and Wiring Diagrams	
Piping Legend.....	9
125 Zone Circulator Pumps - Piping Diagram	10
125 W/ Indirect Zone Pumps, DHW Tank, Tank Sensor - Wiring Diagram.....	11
125 W/ Indirect Zone Pumps & DHW Tank, Tank T-Stat - Wiring Diagram.....	12
125 With Zone Valves - Piping Diagram.....	13
125 With Zone Valves, DHW Tank, Tank Sensor - Wiring Diagram	14
125 Indirect Zone Valves, DHW Tank W/ Tank T-Stat - Wiring Diagram	15
165 With Zone Circulator Pumps - Piping Diagram	16
165 Indirect Zone Pumps, DHW Tank, Tank T-Stat - Wiring Diagram.....	17
165 With Zone Valves - Piping Diagram.....	18
165 Indirect Zone Valves, DHW Tank, Tank T-Stat - Wiring Diagram	19
115, 150 & 205 With Zone Circulator Pumps - Piping Diagram	20
115, 150 & 205 With Zone Pumps - Wiring Diagram	21
115, 150 & 205 With Zone Valves - Piping Diagram	22
115, 150 & 205 With Zone Valves - Wiring Diagram.....	23
Buffer Tank Piping and Wiring	
Buffer Tank - Piping Diagram.....	24
Buffer Tank - Wiring Diagram	25
Optional Equipment & Accessories	
Outdoor Temperature Sensor.....	26
Indirect Storage Tank Sensor & Thermostat.....	27
Wiring Diagrams	
125 - Heat Only Wiring Diagram	29
165 - Heat Only Wiring Diagram	30
115 - Combi Wiring Diagram	31
150 - Combi Wiring Diagram	32
205 - Combi Wiring Diagram	33
Altitude Effects On Boiler Performance	34
Application Table - Indirect Tank Sizing	35
Low Water Cutoff Application	36
Error Code Table	39
Troubleshooting Chart	40
Fault Solution Sections	42
Parameter Change History Log	46

IMPORTANT SAFETY INFORMATION

1. Become familiar with symbols identifying potential hazards.



This is the safety alert symbol. Symbol alerts you to potential personal injury hazards. Obey all safety messages following this symbol to avoid possible injury or death.

DANGER

Indicates a hazardous situation which, if not avoided, WILL result in death or serious injury.

WARNING

Indicates a hazardous situation which, if not avoided, could result in death or serious injury.

CAUTION

Indicates a hazardous situation which, if not avoided, could result in minor or moderate injury.

2. General

Boiler installation shall be completed by qualified agency. See Installation, Operation & Maintenance Manual for additional information.

WARNING

Fire, explosion, asphyxiation and electrical shock hazard. Improper installation could result in death or serious injury. Read this manual and understand all requirements before beginning installation.

WARNING

Fire, Explosion, Asphyxiation, Electrical shock hazard! Flooding will result in damages such as electrical problems, corrosion, inoperative parts, mold and other unforeseen issues which can occur over time. Any equipment determined by a professional as damaged by a flood, defined as excess of water or other liquid, shall be replaced. Failure to follow these directions will result in a Hazardous Situation.

3. Installation shall conform to requirements of authority having jurisdiction or in absence of such requirements:

- *United States*
 - National Fuel Gas Code, ANSI Z223.1/NFPA 54.
 - National Electrical Code, NFPA 70.
- *Canada*
 - Natural Gas and Propane Installation Code, CAN/CSA B149.1.
 - Canadian Electrical Code, Part I, Safety Standard for Electrical Installations, CSA C22.1

4. Where required by authority having jurisdiction, installation shall conform to Standard for Controls and Safety Devices for Automatically Fired Boilers, ANSI/ASME CSD-1.

Additional manual reset low water cutoff and/or high limit may be required.

5. Requirements for Commonwealth of Massachusetts:

Boiler installation must conform to Commonwealth of Massachusetts code 248 CMR which includes but is not limited to:

- Installation by licensed plumber or gas fitter.

LABOR SAVING PIPING MANIFOLDS / NEAR BOILER PIPING CONNECTIONS

**125 HEATING ONLY
WITH OPTIONAL INDIRECT DHW
CONNECTION**

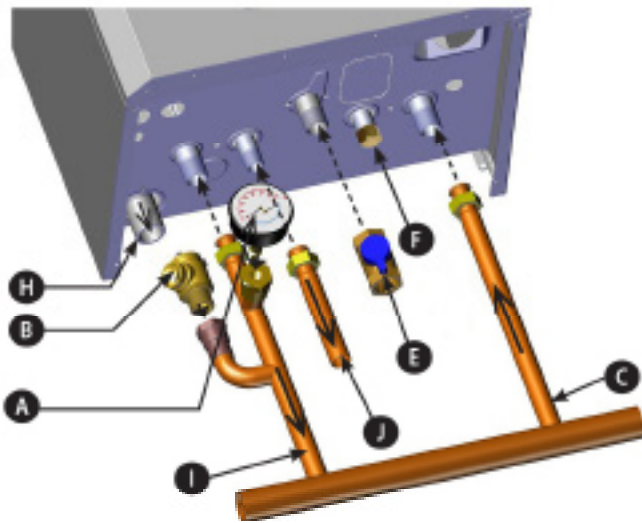

**125 HEATING ONLY
WITHOUT OPTIONAL INDIRECT
DHW CONNECTION**

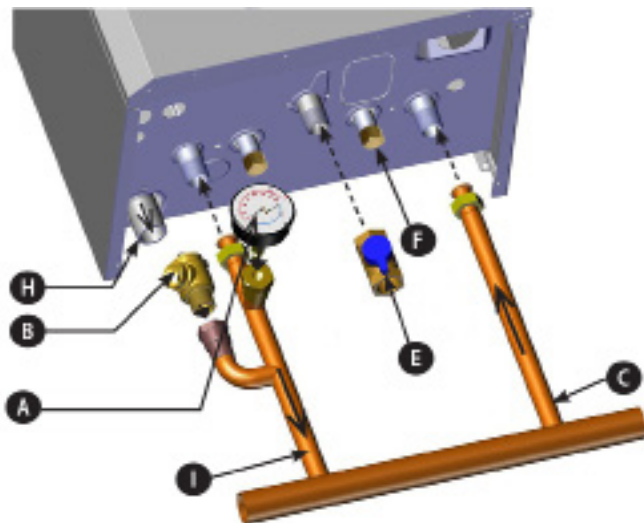

**MANIFOLD
115/125/150**



165 HEATING ONLY

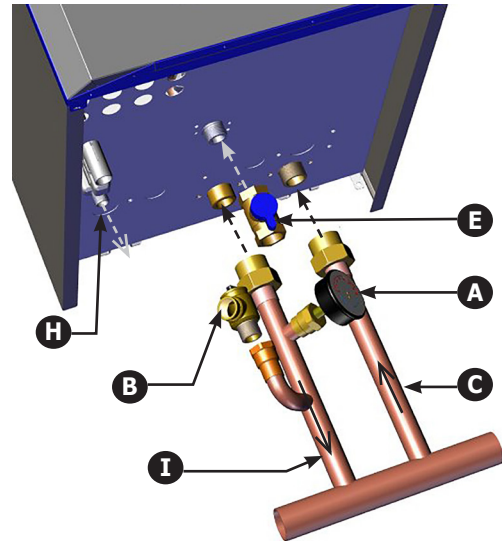

LEGEND		125	165
A	Pressure Gauge	-	
B	Pressure Relief Valve	30.00 psi [2.11 bar]	
C	Heating return connection	3/4" [22.2mm]	1" [25.4mm]
E	Gas shutoff connection	3/4" [22.2mm]	
F	Boiler filling connection (some models)	1/2" [15.9mm]	na
H	Drain connection for condensate	13/16" [21mm] ID Hose	3/4 NPT
I	Heating supply connection	3/4" [22.2mm]	1" [25.4mm]
J	Optional Indirect DHW connection	3/4" [22.2mm]	na

**MANIFOLD
165**

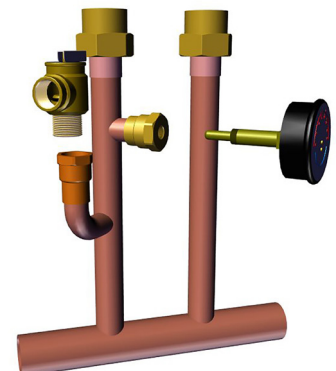

LABOR SAVING PIPING MANIFOLDS / NEAR BOILER PIPING CONNECTIONS

115 & 150 COMBI

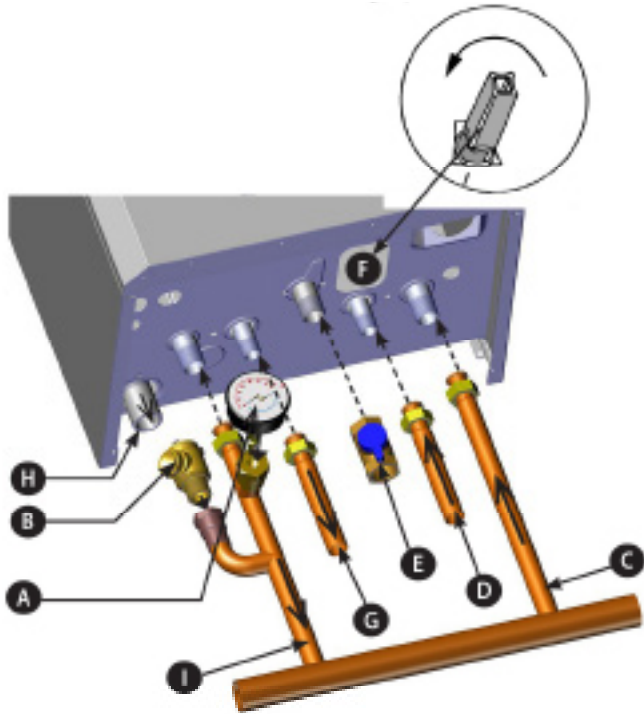

205 COMBI

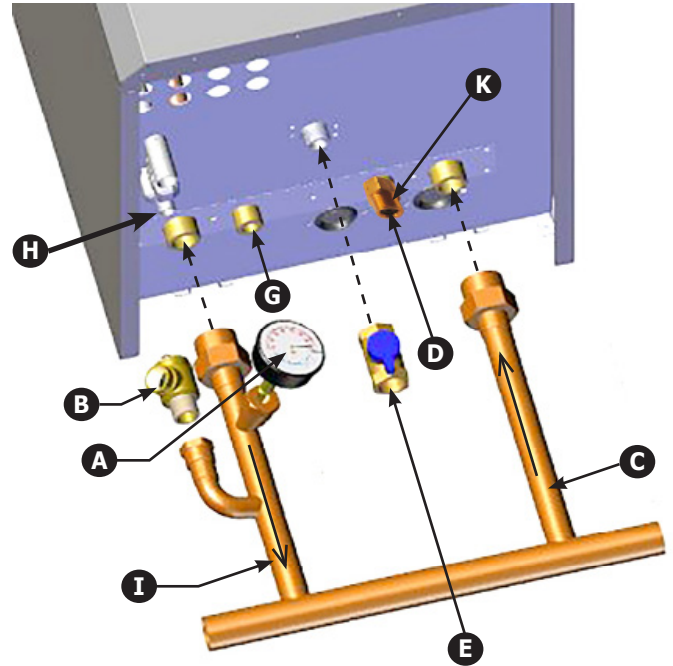

MANIFOLD 115/150/205

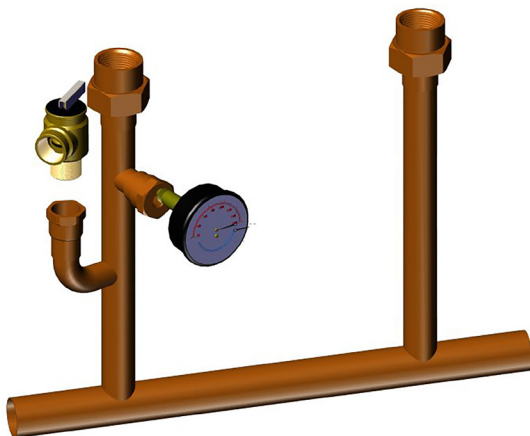

LEGEND		115 & 150	205
A	Pressure Gauge	-	
B	Pressure Relief Valve	30.00 psi [2.11 bar]	
C	Heating return connection	3/4" [22.2mm]	1" [25.4mm]
D	Cold DHW inlet tap	1/2" [15.9mm]	3/4" NPT
E	Gas shutoff connection	3/4" [22.2mm]	
F	Boiler filling connection (some models)	1/2" [15.9mm]	na
G	DHW outlet	1/2" [15.9mm]	3/4" NPT
H	Drain connection for condensate	13/16" [21mm] ID Hose	3/4" NPT
I	Heating supply connection	3/4" [22.2mm]	1" [25.4mm]
K	5 gpm DHW flow restrictor (Factory installed) (205 only)	na	3/4" [22.2mm]

GENERAL INFORMATION - HYDRONIC PIPING

⚠ WARNING

Burn and scald hazard! Manufacturer requires installation of field supplied anti-scald valve. Failure to follow these instructions could result in death or serious injury.

General Information:

Piping installation, materials, and joining methods shall conform to requirements of authority having jurisdiction or in absence of such requirements:

- **USA** - National Fuel Gas Code, ANSI Z223.1/NFPA 54
- **Canada** - Natural Gas and Propane Installation Code, CAN/CSA B149.1

Manufacturer Requirements/Recommendations:

- **Manufacturer requires all domestic hot water (DHW) installations use an anti-scald valve.** Local codes may require additional equipment (expansion tank, relief valves, etc.) Select and size equipment to suit installation and meet code requirements.
- Use of a water filter on incoming water supply line.
- Manufacturer recommends use of a magnetic dirt separator in the hydronic system where there are cast iron or steel components, or where the previous boiler was a cast iron heat exchanger. The abrasive, extremely fine sediment is difficult to remove and can deposit onto heat exchanger surfaces and accumulate in pump cavities causing reduced efficiency and premature wear.
- If the piping manifold is not used the ASME temperature and pressure relief valve and temperature and pressure gauge shall be installed to conform to requirements of the authority having jurisdiction. Refer to appropriate manufacturer instructions for installation requirements.
- If the piping manifold is not used, a primary / secondary piping arrangement is manufacturer required. A maximum of 12" of separation between the supply and return pipe (closely spaced tees) of the boiler shall be maintained.
- Limit combined supply and return pipe lengths to maximum linear lengths of 20 ft (6.1 m) between boiler and closely spaced tees, when minimum ¾" NPT pipe size is used. Linear length may be increased if supply and return pipe size is increased to limit pressure drop.
- Manufacturer recommends installing a shutoff and purge valve to use during commissioning to ensure the boiler does not shut down due to over temperature. Do not install shutoff between boiler and LWCO or pressure relief valve.

FOR YOUR SAFETY READ BEFORE OPERATING

⚠ DANGER



Hot Water Can Scald!

Water heated to temperature for clothes washing, dish washing and other sanitizing needs can scald and cause permanent injury. Children, elderly, and infirm or physically handicapped persons are more likely to be permanently injured by hot water. Never leave them unattended in bathtub or shower. Never allow small children to use a hot water tap or draw their own bath.

If anyone using hot water in the building fits the above description, or if state laws or local codes require certain water temperatures at hot water taps, you must take special precautions:

- Use lowest possible temperature setting.
- Install some type of tempering device, such as an automatic mixing valve, at hot water tap or water heater. Automatic mixing valve must be selected and installed according to manufacturer's recommendations and instructions.
- Water passing out of drain valves may be extremely hot. To avoid injury:
 - Make sure all connections are tight.
 - Direct water flow away from any person.

GENERAL INFORMATION - HYDRONIC PIPING

Water Temperature Setting	1st Degree Burn Exposure Time For An Adult	2nd and 3rd Degree Burn Exposure Time For An Adult
120° F	1 minute	5 minutes
130° F	5 seconds	30 seconds
140° F	2 seconds	5 seconds
150° F	1 second	1.5 seconds
160° F	Instantaneous	0.5 seconds

Note: Warning for Infants, Children, and Elderly: Great care must be taken when exposing the aforementioned groups to warm or hot water as they can be badly burned in exposure times less than half of the time for an adult.

Note → Provided Wiring and Piping illustrations are meant to show system concepts only. Installer is responsible for all equipment required by authority having jurisdiction.

Note → Arrange piping to prevent water dripping onto boiler.

All piping diagrams are shown with optional DHW Indirect Tank where applicable.

Use of Indirect Storage Tank (DHW):

Note → Sensors supplied with this boiler are proprietary to the manufacturer. Use of alternate sensors *WILL* diminish boiler performance.

- Use either DHW sensor or Indirect Tank Thermostat to interface with boiler. Wire to M2 terminals #3 and #4.
- Use of booster pump to increase flow rate to indirect tank is not recommended by manufacturer.
- Locate tank as close to boiler as possible.
- Size DHW tank, piping, and system to use only internal boiler pump.
- See available pump/flow rate chart, page 35 of this manual.
- Change P03 on boiler for application as specified on the wire diagram and Boiler Control section of Installation, Operation & Maintenance Manual supplied with the boiler.

The Labor Saver Piping Manifold, which is supplied with each boiler, is shown with most of the following piping diagrams.

GENERAL INFORMATION - WIRING

Electrical Wiring Information:

All field wiring shall conform to the authority having jurisdiction or, in the absence of such requirements to:

- **USA:** National Electrical Code, ANSI/NFPA 70,
- **Canada:** Canadian Electrical Code, Part I, CSA C22.1: Safety Standard for Electrical Installations.

Wiring diagrams shown in this manual utilize the ARGO™ Universal Control, the optional use of an Indirect Domestic Hot Water Tank, and optional use of a H2O Buffer Tank.

Reference the zone control manufacturer instruction manual for control operation and priority setting of DHW zones.

Note → **DO NOT** use 120 V thermostat terminals (m1- #1 and #2).

Note → Provided Wiring and Piping illustrations are meant to show system concepts only. Installer is responsible for all equipment required by authority having jurisdiction.

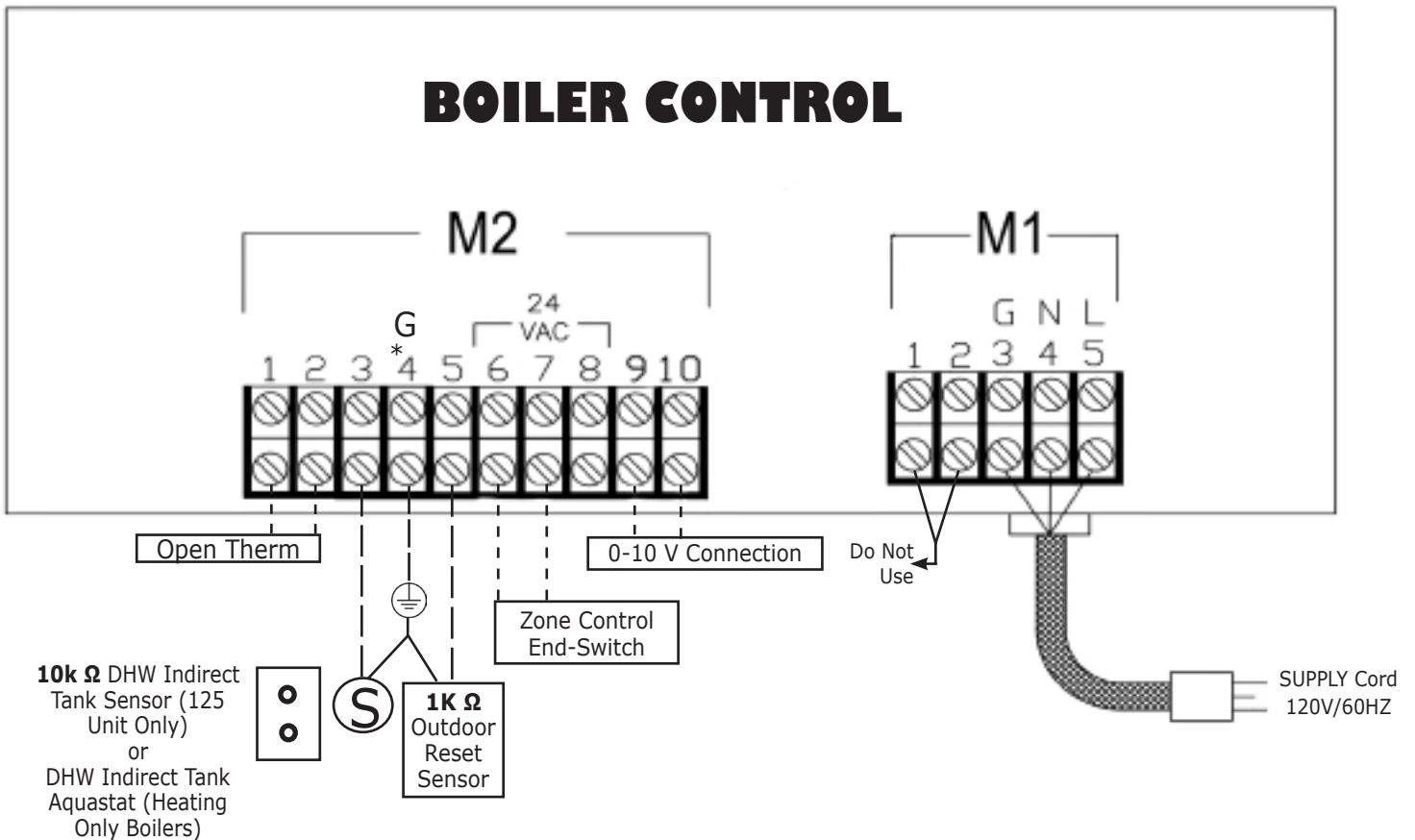

* Ground Sensors using terminal 4

PIPING LEGEND

PIPING LEGEND



ZONE VALVE



BALL VALVE



AIR SEPERATOR



CIRCULATOR



DRAIN

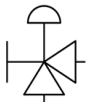

COMBINATION FILL



FLOW CHECK VALVE



BYPASS VALVE



DIVERTER VALVE



T&P OR RELIEF VALVE



THERMOSTATIC MIXING VALVE

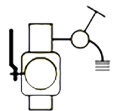

PURGE VALVE

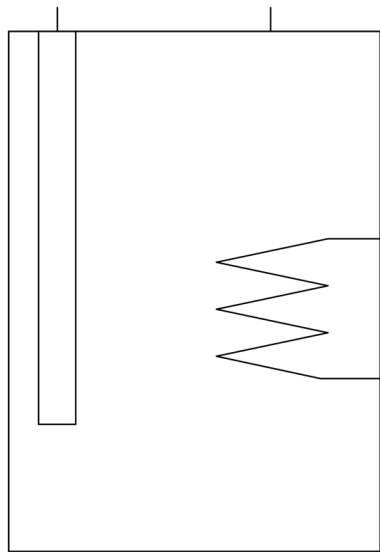

INDIRECT DHW TANK



INDIRECT TANK AQUASTAT



10K Ω INDIRECT DHW TANK SENSOR



TEMPERATURE & PRESSURE GAUGE

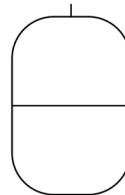

EXPANSION TANK

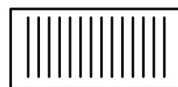

FLAT PLATE HEAT EXCHANGER
(COMBI ONLY)



STRAINER

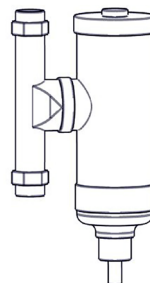

MAGNETIC DIRT SEPARATOR

125 with Zone Circulator Pumps

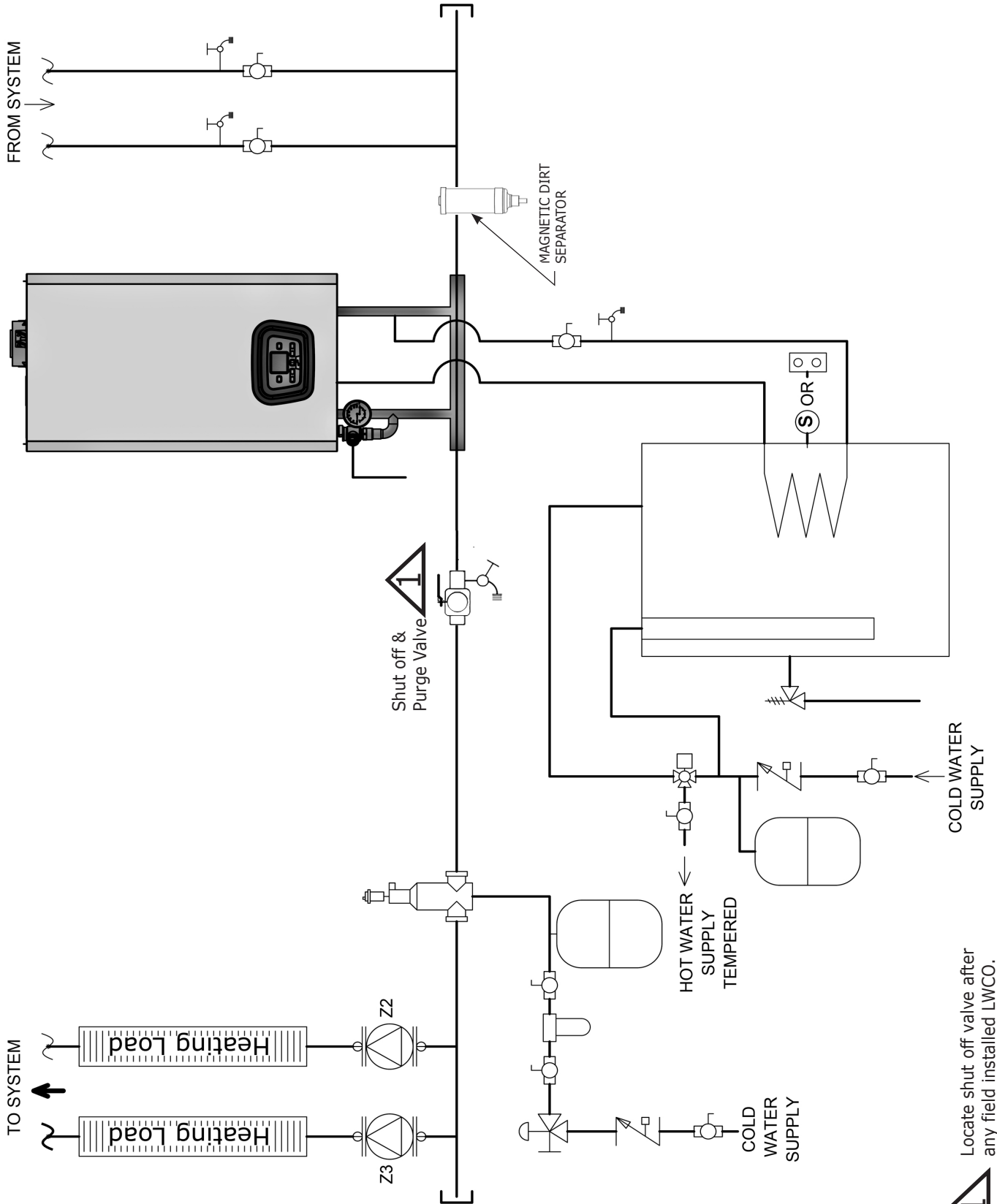

1 Locate shut off valve after any field installed LWCO.

125 WITH INDIRECT ZONE PUMPS & DHW TANK W/ TANK SENSOR

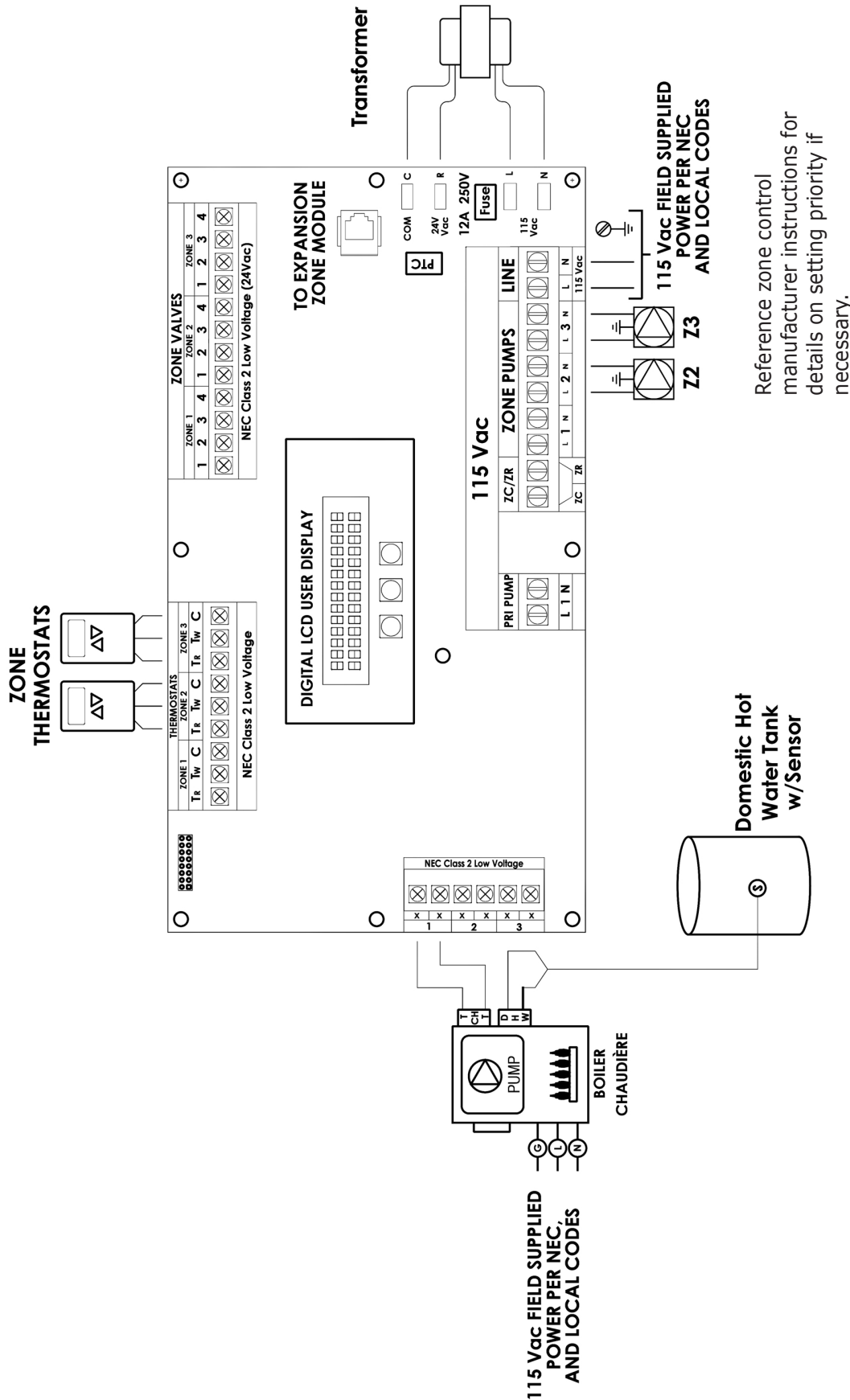

Reference zone control manufacturer instructions for details on setting priority if necessary.

If adding an indirect tank with **sensor** to a **Heating Only Boiler**, change P03 from 08 to 05. See Section 9, Parameter Settings in Boiler Installation, Operation & Maintenance Manual for details.

125 W/ INDIRECT ZONE PUMPS & DHW TANK W/TANK T-STAT - WIRING DIAGRAM

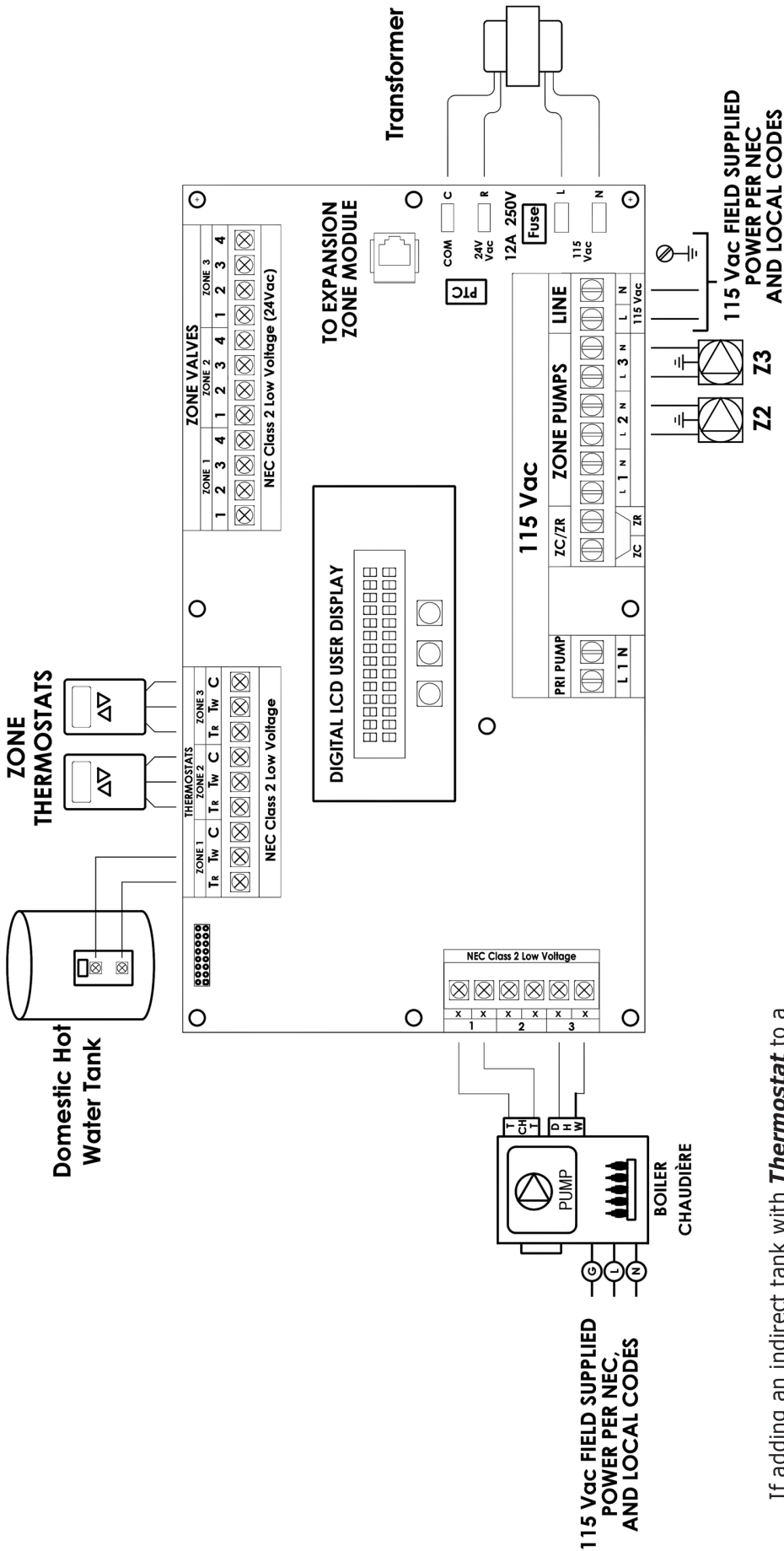

Reference zone control manufacturer instructions for details on setting priority if necessary.

If adding an indirect tank with **Thermostat** to a **Heating Only Boiler**, change P03 from 08 to 04. See Section 9, Parameter Settings in Boiler Installation, Operation & Maintenance Manual for details.

125 WITH ZONE VALVES - PIPING DIAGRAM

125 with Zone Valves

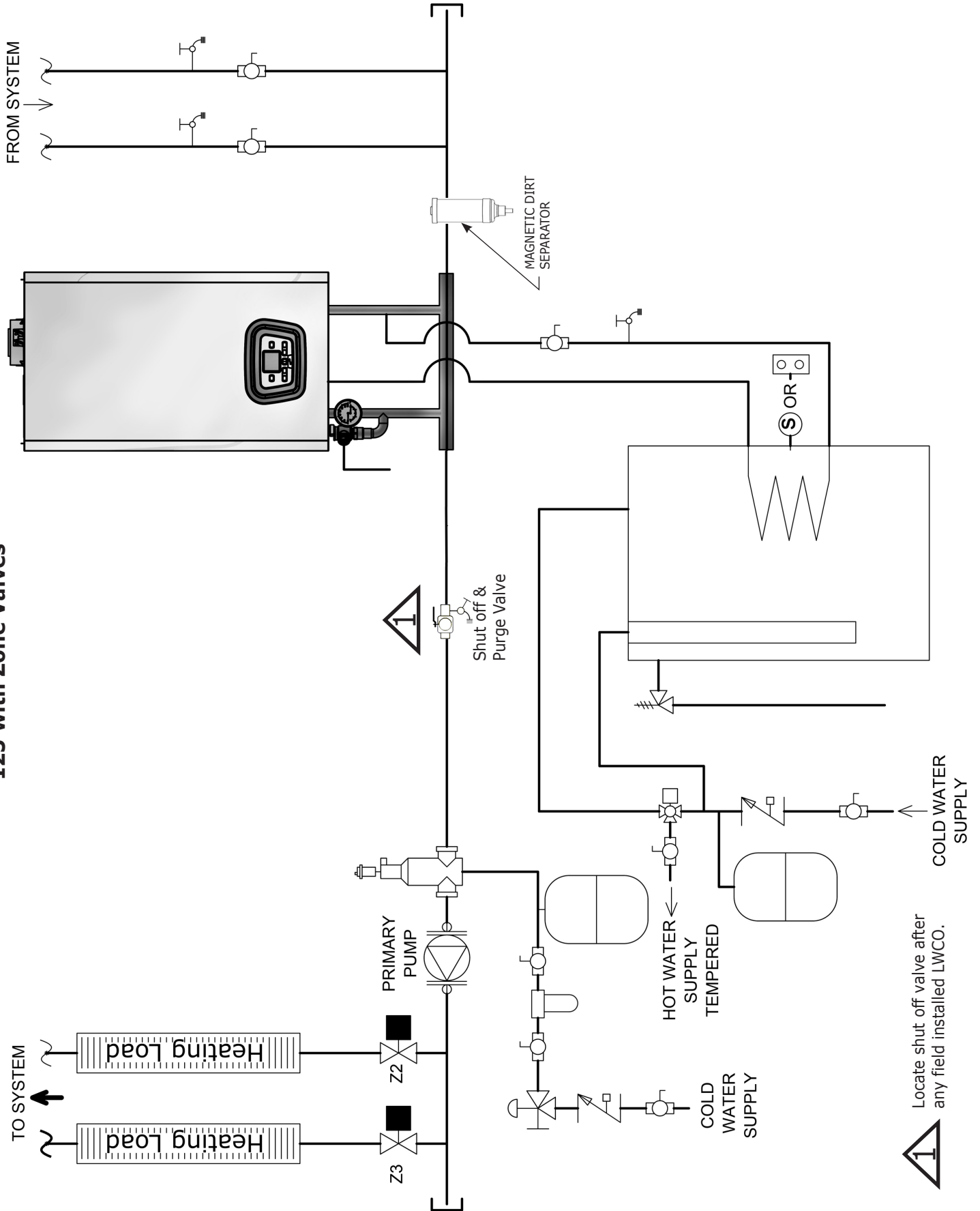

Locate shut off valve after any field installed LWCO.

125 with Zone Valves

125 With Zone Valves, DHW Tank & Tank Sensor

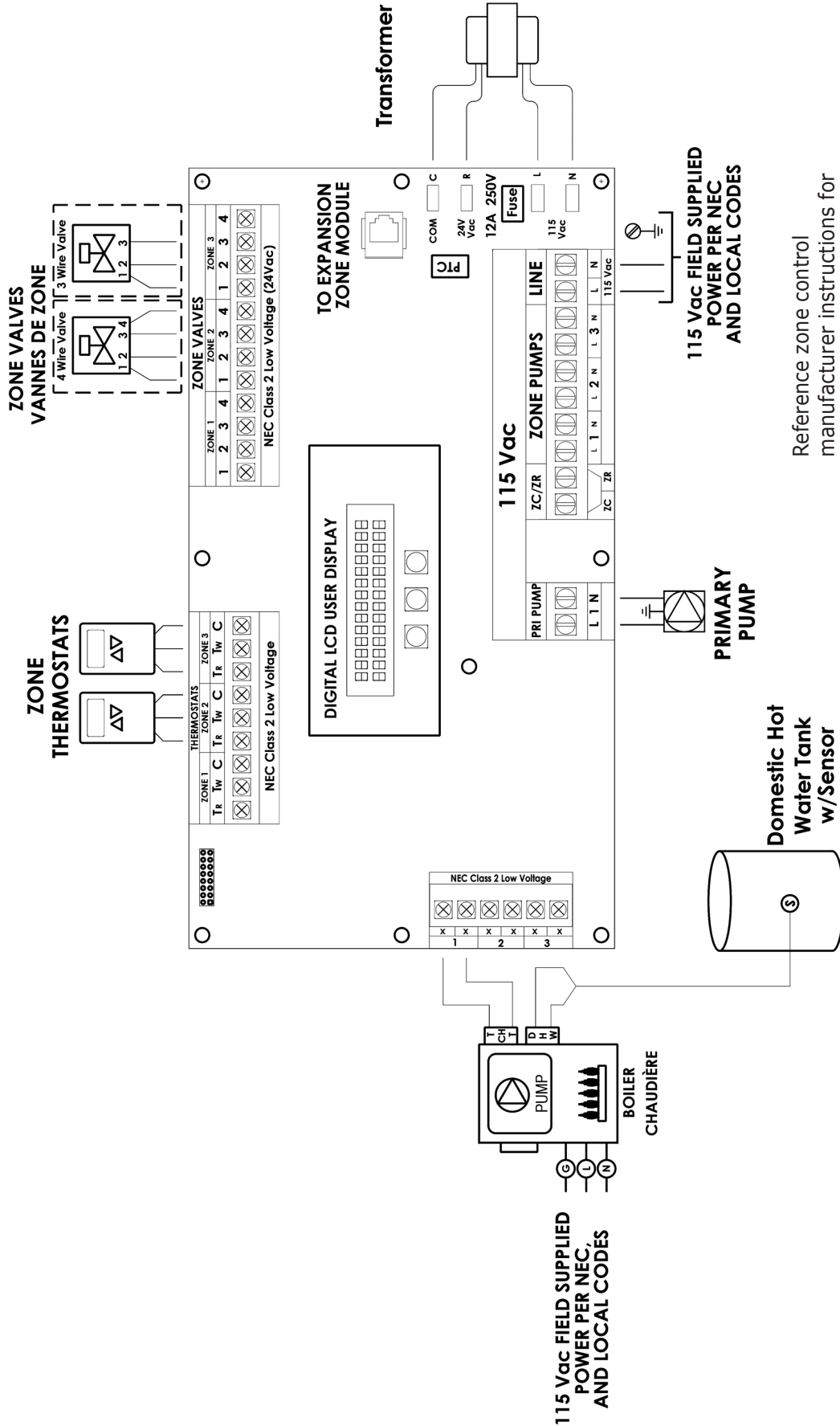

Reference zone control manufacturer instructions for details on setting priority if necessary.

If adding an indirect tank with **sensor** to a **Heating Only Boiler**, change P03 from 08 to 05. See Section 9, Parameter Settings in Boiler Installation, Operation & Maintenance Manual for details.

125 with Zone Valves

125 Indirect Zone Valves, DHW Tank, & Tank T-STAT

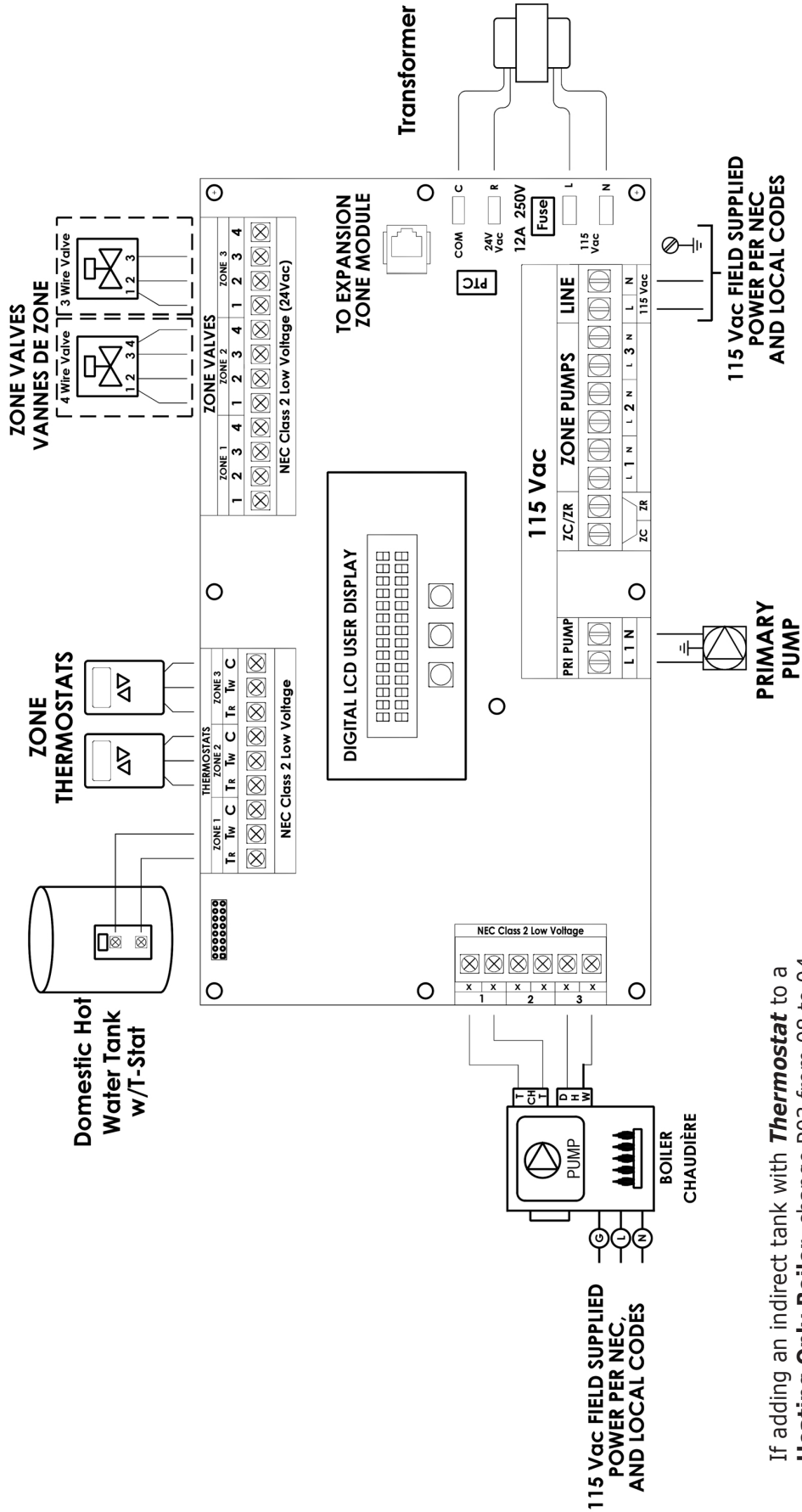

If adding an indirect tank with **Thermostat** to a **Heating Only Boiler**, change P03 from 08 to 04. See Section 9, Parameter Settings in Boiler Installation, Operation & Maintenance Manual for details.

165 WITH ZONE CIRCULATOR PUMPS - PIPING DIAGRAM

165 with Zone Circulator P_{ives}

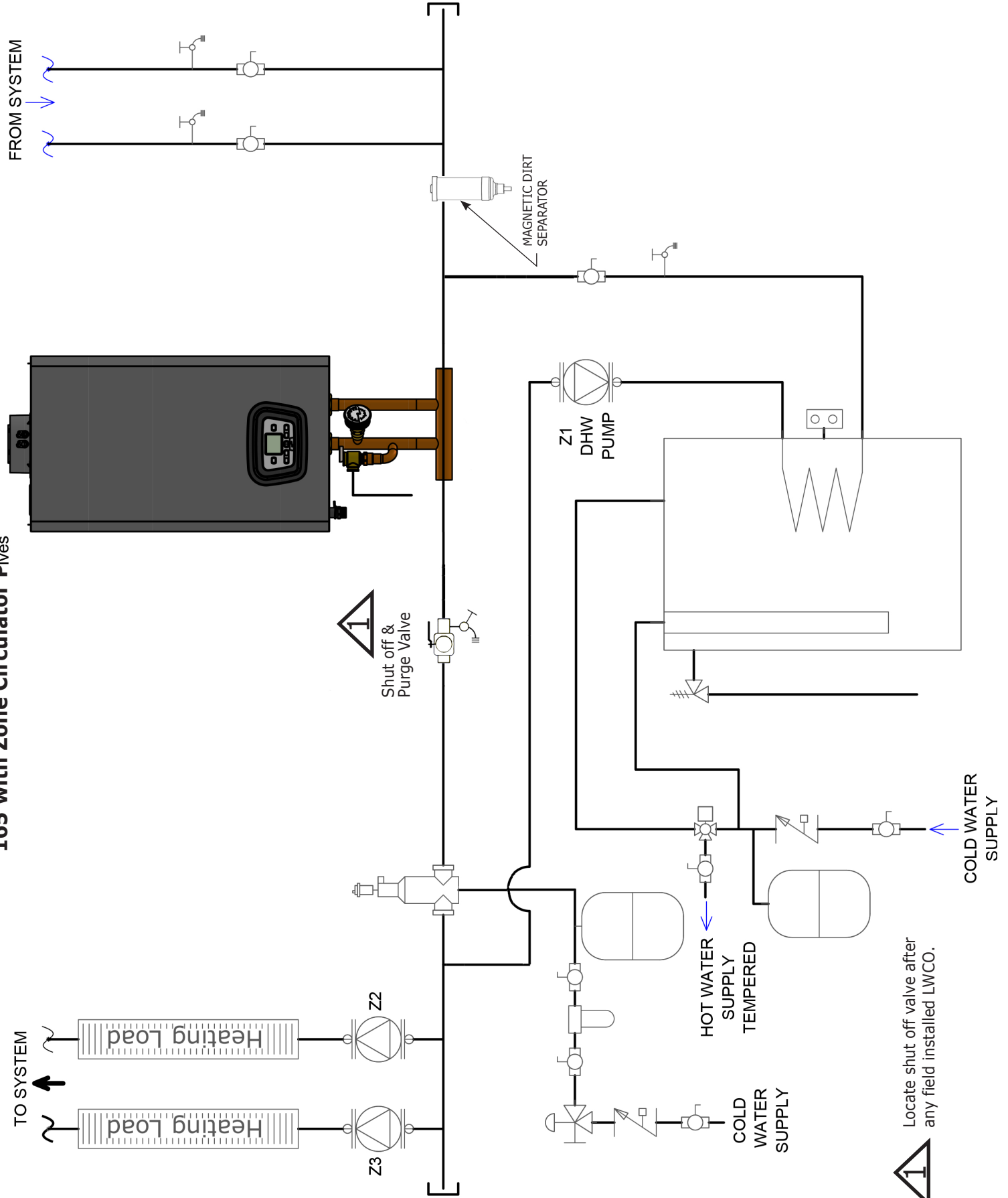

1
Locate shut off valve after any field installed LWCO.

165 Indirect Zone Pumps, DHW Tank, Tank T-Stat

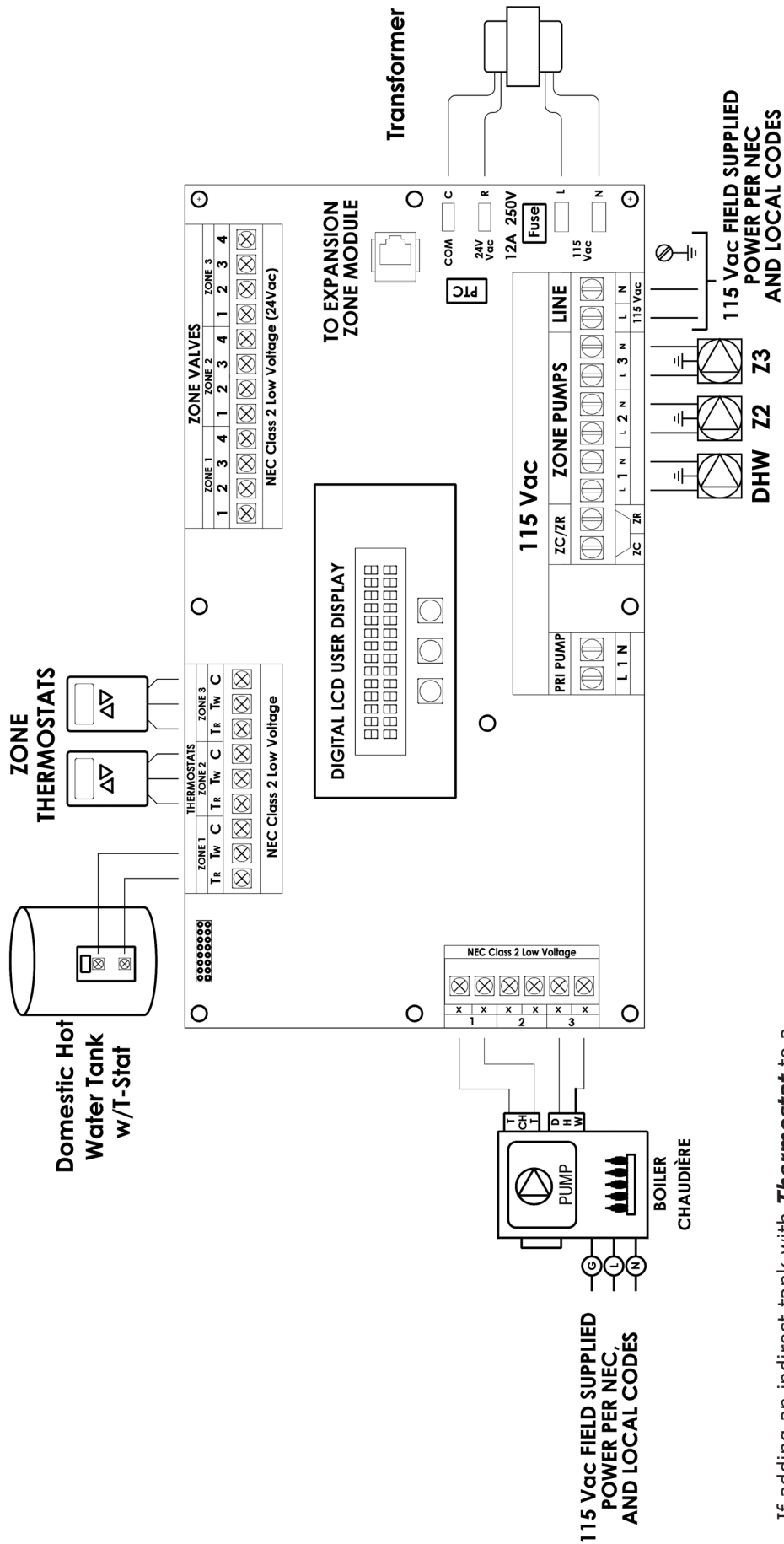

If adding an indirect tank with **Thermostat** to a **Heating Only Boiler**, change P03 from 08 to 04. See Section 9, Parameter Settings in Boiler Installation, Operation & Maintenance Manual for details.

165 WITH ZONE VALVES - PIPING DIAGRAM

165 with Zone Valves

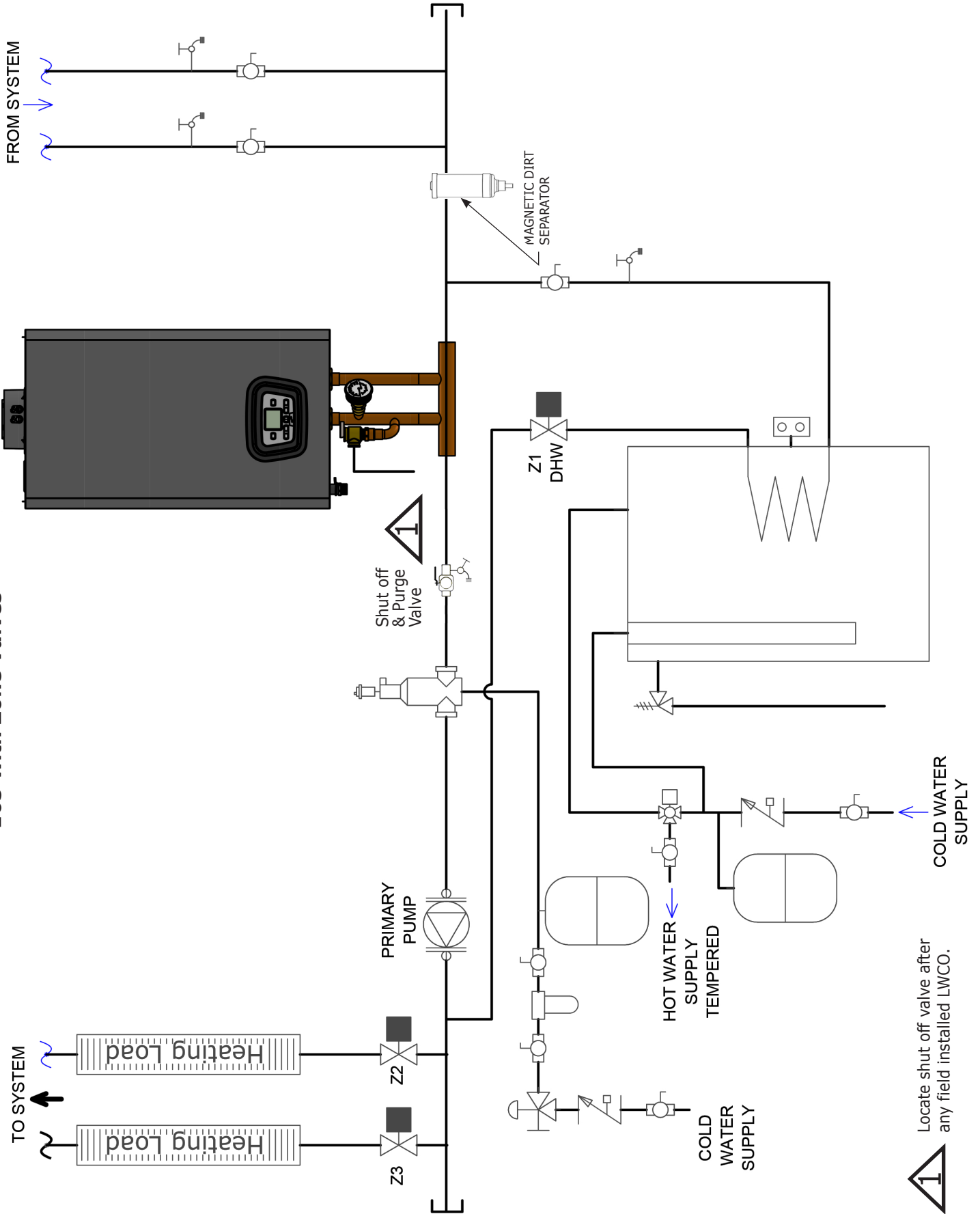

Locate shut off valve after any field installed LWCO.

165 Indirect Zone Valves, DHW Tank, Tank T-STAT -Wiring Diagram

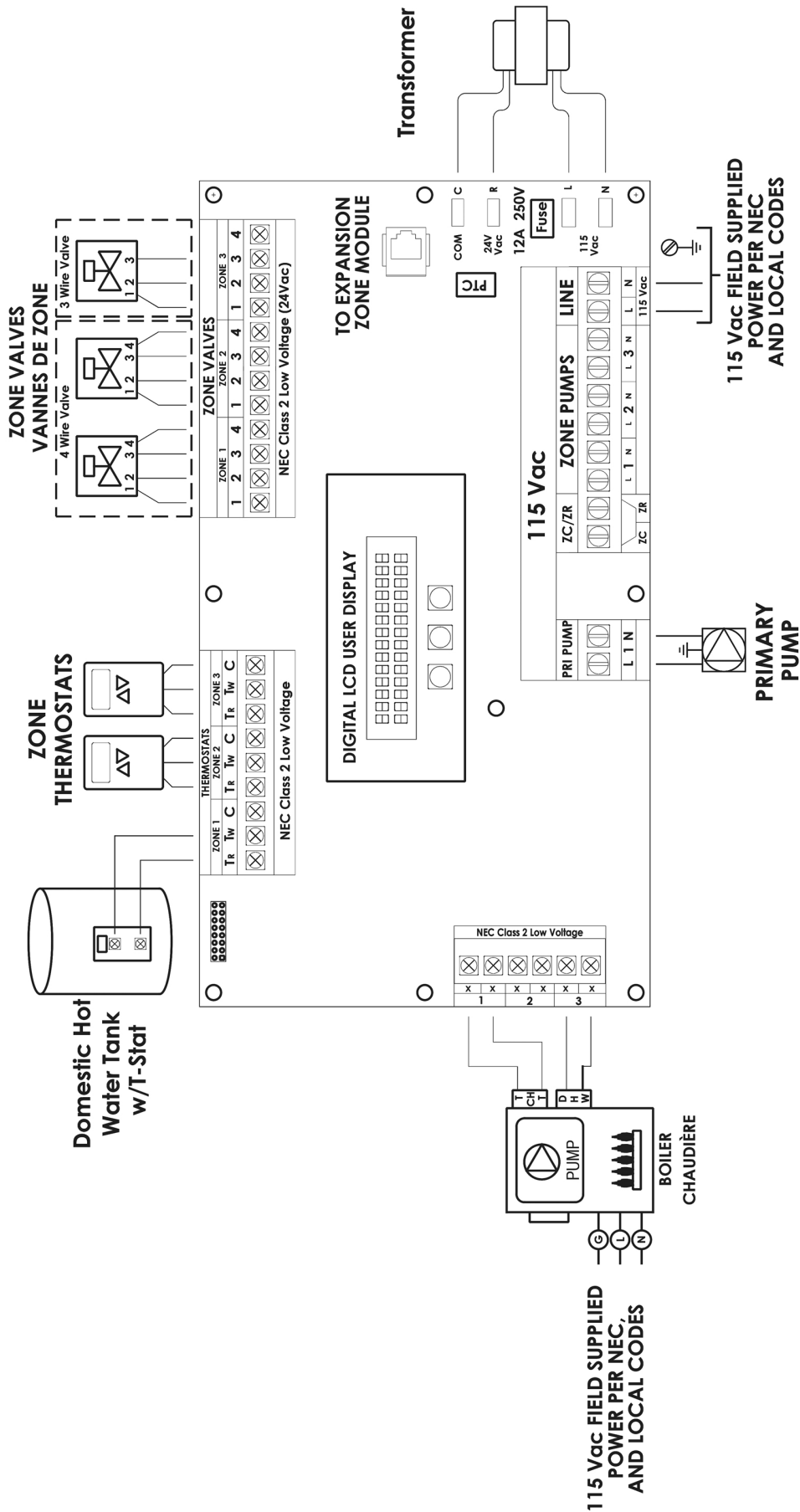

Reference zone control manufacturer instructions for details on setting priority if necessary.

If adding an indirect tank with **Thermostat** to a **Heating Only Boiler**, change P03 from 08 to 04. See Section 9, Parameter Settings in Boiler Installation, Operation & Maintenance Manual for details.

115, 150 & 205 with Zone Circulator Pumps

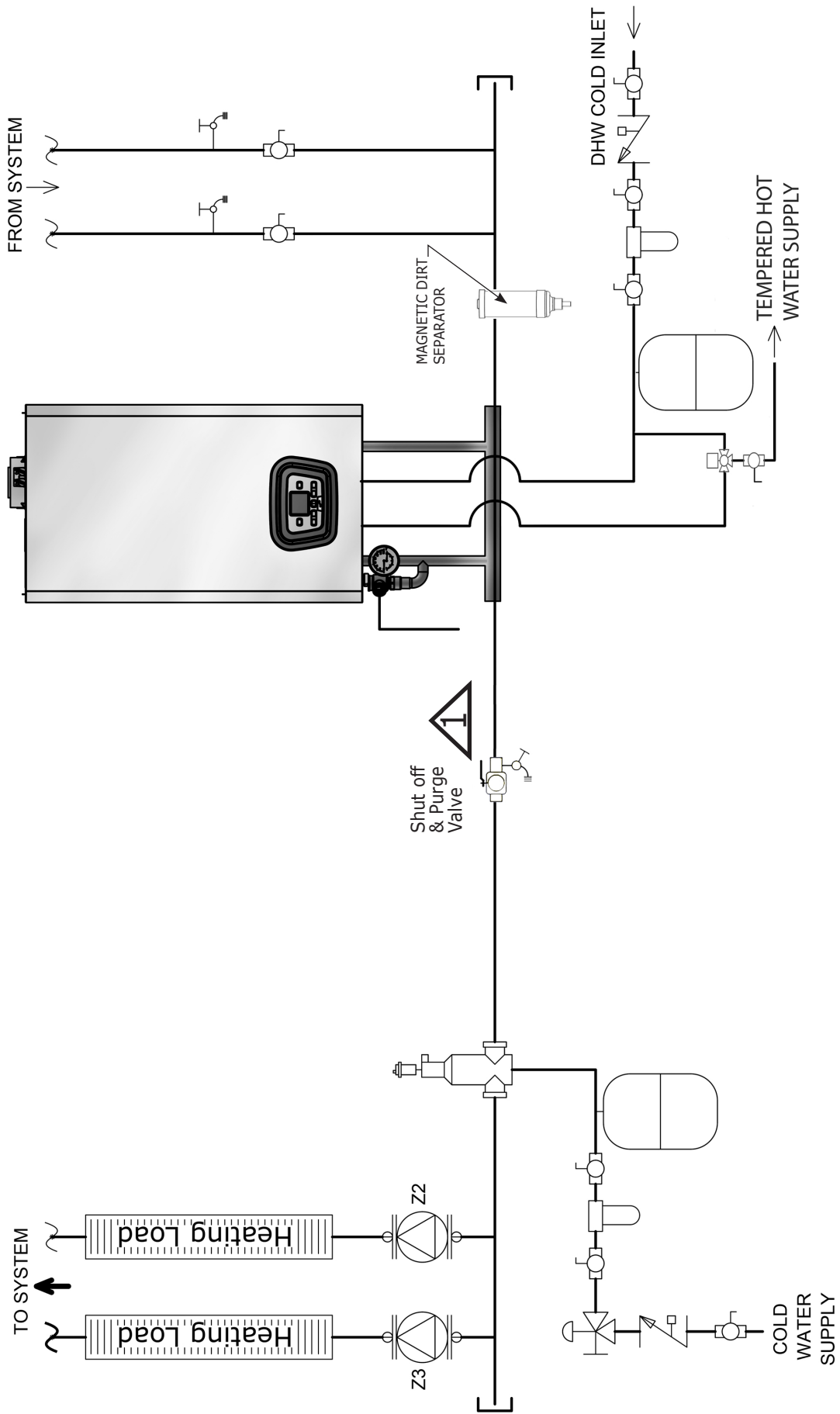

Locate shut off valve after any field installed LWCO.



150 & 205 With Zone Pumps

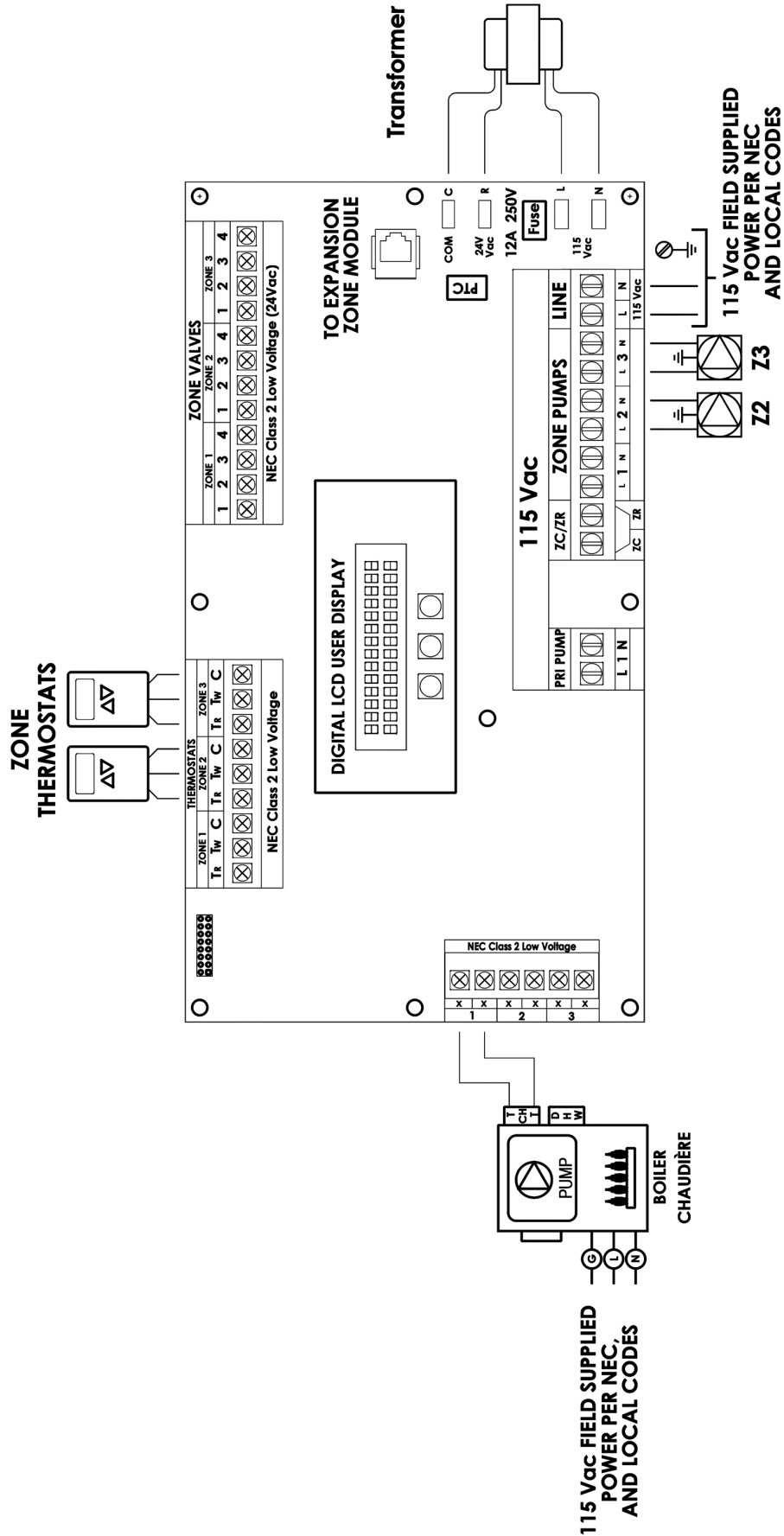

115, 150 & 205 with Zone Valves

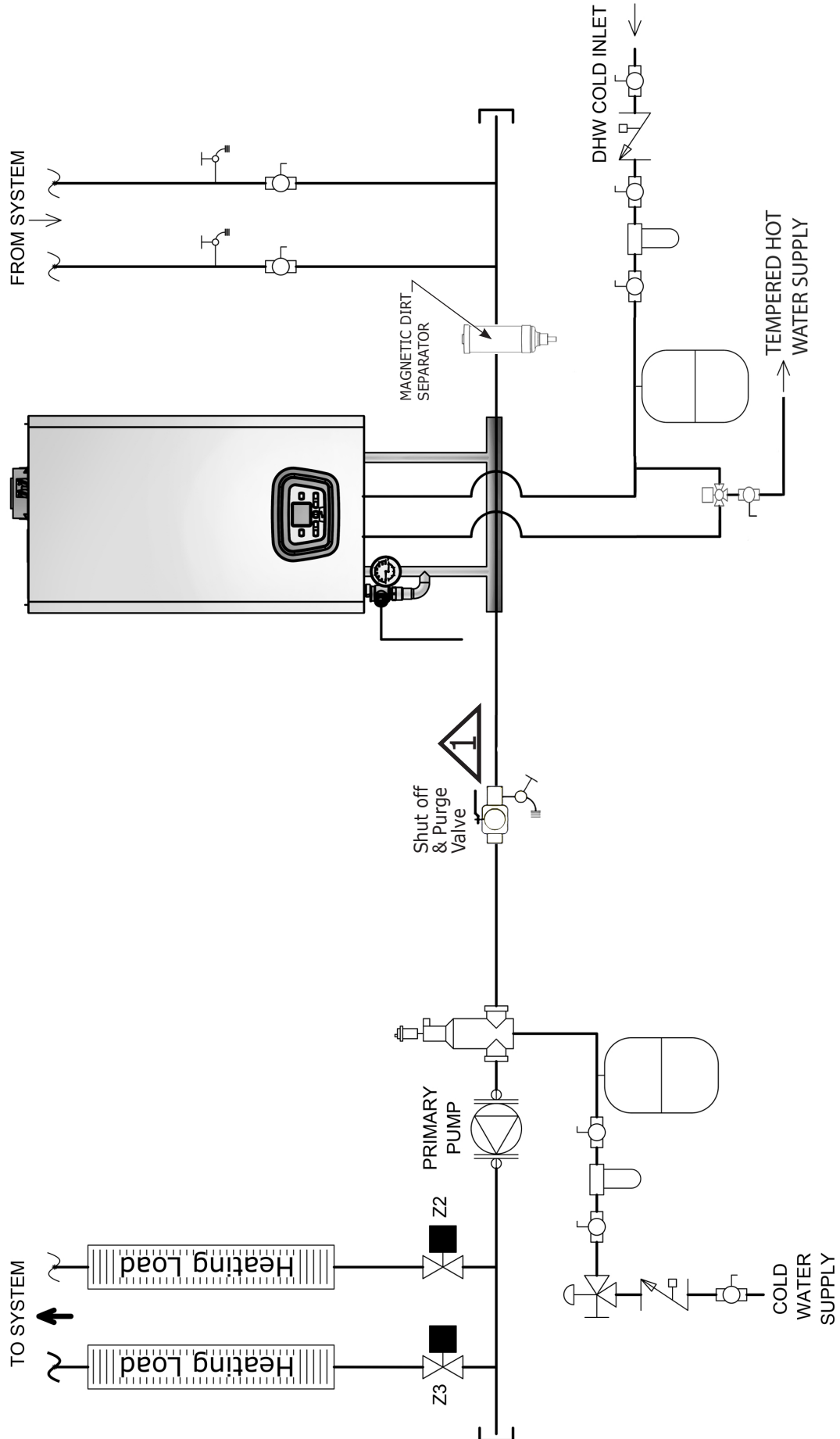

1
Locate shut off valve after any field installed LWCO.

115, 150 & 205 With Zone Valves

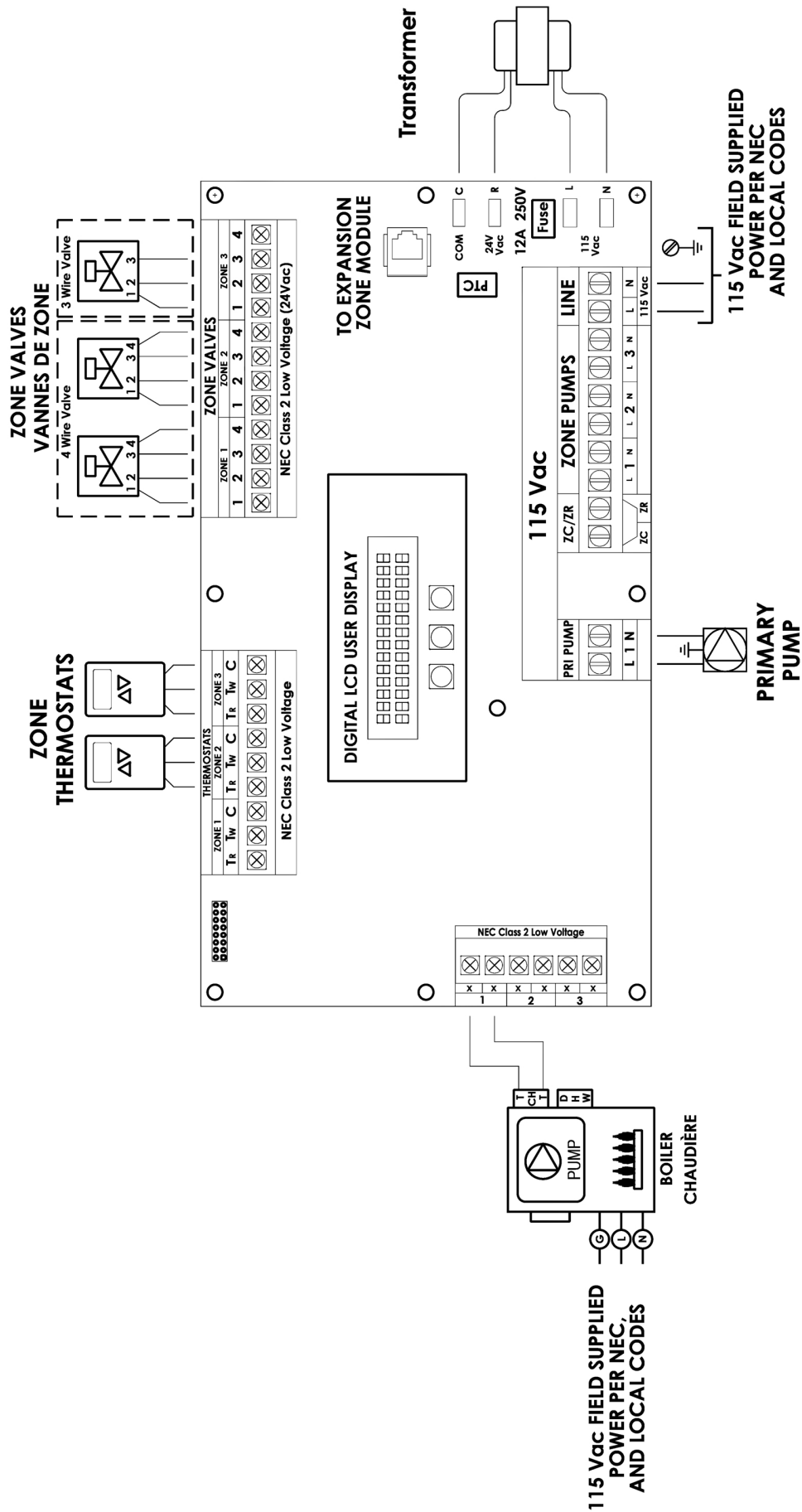

Buffer Piping

When installing low mass systems, additional water mass may be required to avoid short cycling by the boiler. In these applications it is recommended that a buffer tank be installed.

Buffer Tank on Central Heat Circuit

Note:

- DHW piping not shown for clarity. Reference applicable sections of this manual for DHW piping details.
- Internal Boiler circulator used on Primary circuit.
- Reference Buffer Tank Installation Manual for proper sizing and installation.

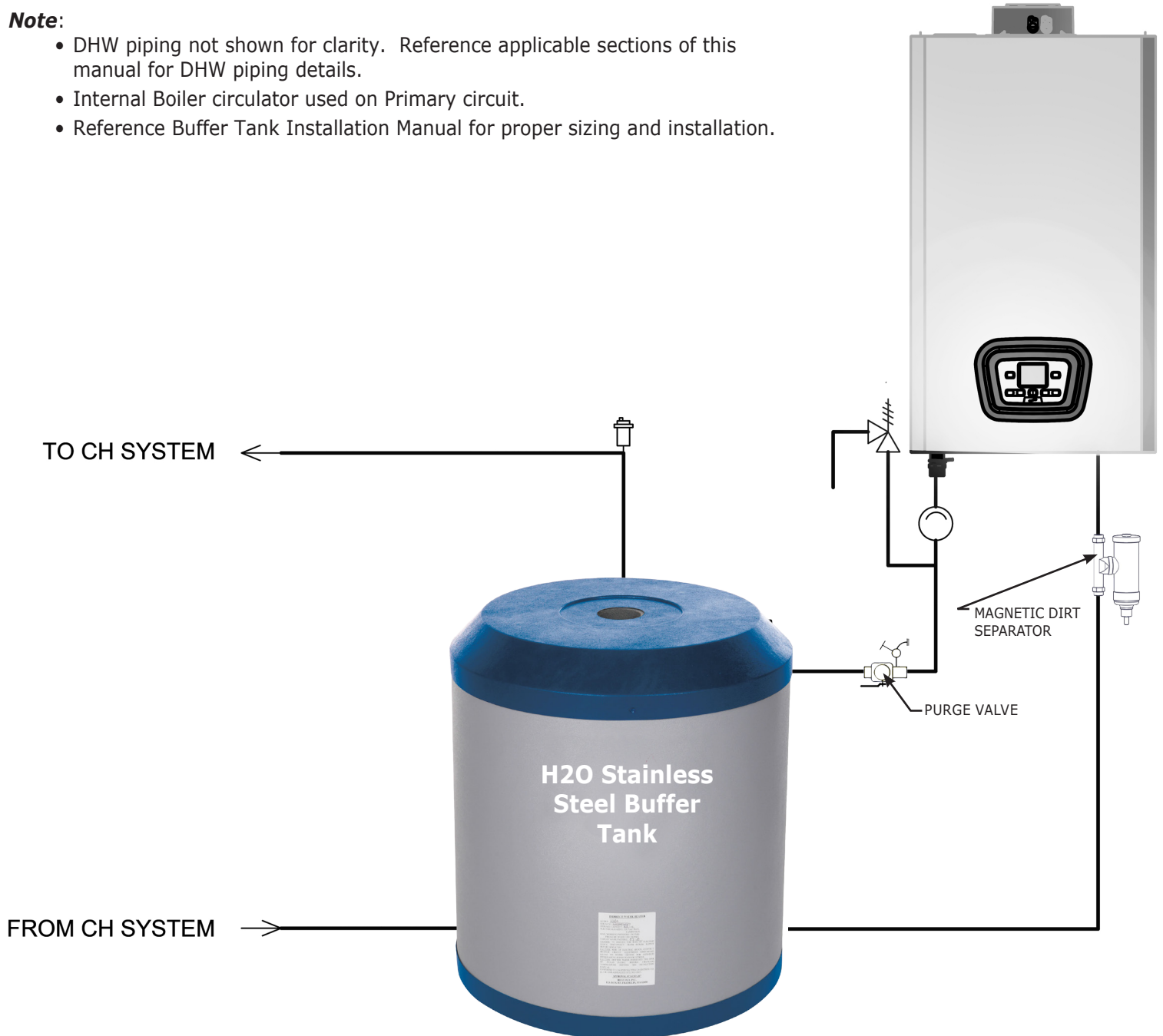

OPTIONAL EQUIPMENT

Optional Equipment

IMPORTANT: Sensors supplied with this boiler are proprietary to the manufacturer. Use of alternate market sensors *WILL* diminish boiler performance.

1. **1k Ω** Outdoor Air Sensor, if used.
 - A. Boiler automatically recognizes sensor when used.
 - B. See Chart 1 for sensor data. Sensor part number BD710487302V
 - C. Locate outdoor sensor to protect against wind and direct sunlight. Mounting instructions provided with sensor.
 - D. Maximum wire length is 100 ft (30m) for 22 ga. wire, or 150 ft (45m) for 18 ga. wire.
 - E. Connect wires to M2 OUTDOOR SENSOR terminals 4 & 5. Wires are interchangeable. See Accessories.

2. **10k Ω** Sensor for Indirect DHW Tank (Heating Only Boiler).
 - A. See Chart 2 for sensor data.
See Accessories section of this manual for wiring diagram.

CHART 1 -1k Ω OUTDOOR AIR SENSOR DATA			
T [°F]	R [Ohm]	T [°F]	R [Ohm]
-4.0	7,578	53.6	1,690
-2.2	7,193	55.4	1,621
-0.4	6,831	57.2	1,555
1.4	6,489	59.0	1,492
3.2	6,166	60.8	1,433
5.0	5,861	62.6	1,375
6.8	5,574	64.4	1,321
8.6	5,303	66.2	1,268
10.4	5,046	68.0	1,218
12.2	4,804	69.8	1,170
14.0	4,574	71.6	1,125
15.8	4,358	73.4	1,081
17.6	4,152	75.2	1,040
19.4	3,958	77.0	1,000
21.2	3,774	78.8	962
23.0	3,600	80.6	926
24.8	3,435	82.4	892
26.6	3,279	84.2	858
28.4	3,131	86.0	827
30.2	2,990	87.8	796
32.0	2,857	89.6	767
33.8	2,730	91.4	740
35.6	2,610	93.2	713
37.4	2,496	95.0	687
39.2	2,387	96.8	663
41.0	2,284	98.6	640
42.8	2,186	100.4	617
44.6	2,093	102.2	595
46.4	2,004	100.4	617
48.2	1,920	102.2	595
50.0	1,840	104.0	575
51.8	1,763	106.0	556

CHART 2 -10k Ω INDIRECT TANK SENSOR DATA			
T [°F]	R [Ohm]	T [°F]	R [Ohm]
32.0	32,505	86.0	8,060
33.8	30,898	87.8	7,726
35.6	29,381	89.6	7,407
37.4	27,946	91.4	7,103
39.2	26,590	93.2	6,813
41.0	25,308	95.0	6,537
42.8	24,094	96.8	6,273
44.6	22,946	98.6	6,021
46.4	21,859	100.4	5,781
48.2	20,829	102.2	5,551
50.0	19,854	104.0	5,332
51.8	18,930	105.8	5,123
53.6	18,054	107.6	4,923
55.4	17,223	109.4	4,732
57.2	16,436	111.2	4,549
59.0	15,689	113.0	4,374
60.8	14,980	114.8	4,207
62.6	14,306	116.6	4,047
64.4	13,667	118.4	3,894
66.2	13,060	120.2	3,748
68.0	12,483	122.0	3,608
69.8	11,935	123.8	3,473
71.6	11,414	125.6	3,345
73.4	10,919	127.4	3,222
75.2	10,447	129.2	3,104
77.0	9,999	131.0	2,991
78.8	9,572	132.8	2,882
80.6	9,166	134.6	2,778
82.4	8,779	136.4	2,679
84.2	8,411	138.2	2,583

ACCESSORIES

Accessories:

1. 1k Ω Outdoor Temperature Sensor Kit - BD710487302V

Use Outdoor Sensor Kit with Heating Only or Combi Boilers. Wire Control to boiler M2 terminal strip terminals 4 and 5 as shown below.

Install/locate Control according to instructions supplied with sensor kit and Installation, Operation and Maintenance Manual (IOM).

Setting "Kt" Climate Curve:

Start boiler in CH mode. Depress CH control button once.





Boiler control will recognize installed OAS sensor. Display will change to show current default "Kt" value. Note display value.

When operation in CH mode, Kt value setting will override maximum CH boiler control set point based on current outdoor temperature.

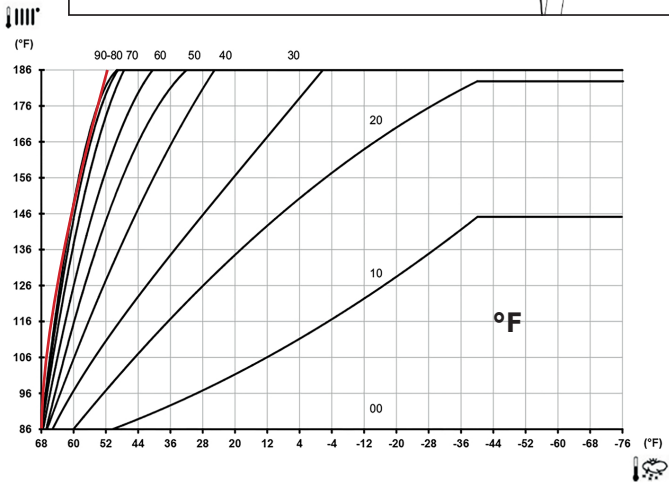
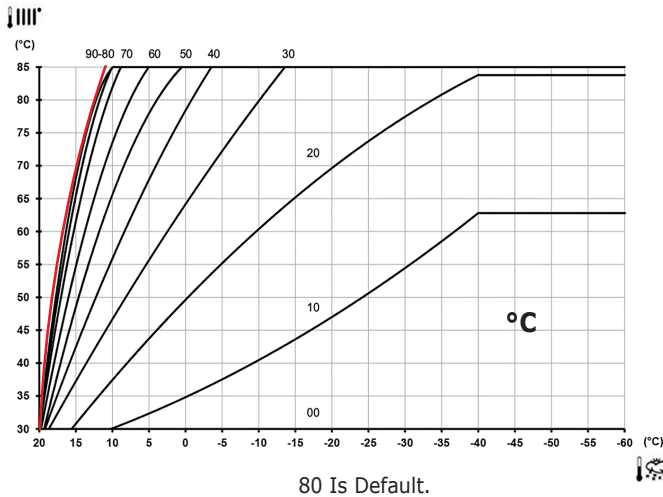
- Refer to applicable °F (or °C) chart,
- Identify Kt range that will satisfy the desired boiler delivery temperature based on average (extreme) outdoor temperature range expected for climate location.



- Use lower value of range as the desired Kt value.
(example): to deliver 176°F water @ OT of -20°F = Kt range is 90 thru 25. Select 25.
- To change "default" Kt value on boiler control use +/- CH Heating buttons.  



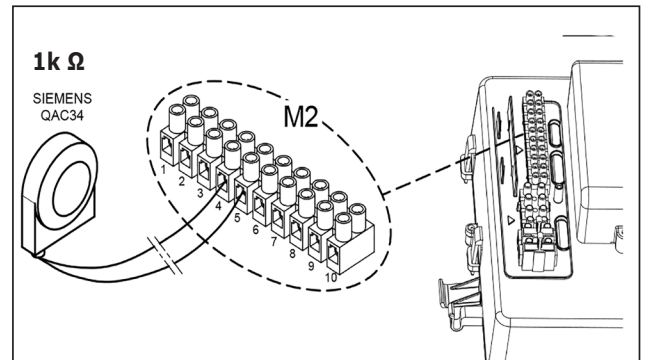

When scrolling has stopped, boiler will automatically "SAVE" value as new Kt default value and automatically return to CH mode when no Kt adjustment activity is sensed. Kt values can be changed in +/- 1 point increments.

To return to check or change current Kt "default value" - depress one of the CH setpoint adjustment buttons (once), while in any heating or standby mode. Adjust Kt value to obtain desired comfort level.



For temperatures below -40°F (-40°C), maximum heating flow temperature set point no longer increases and curves on the graph become horizontal. Boiler set point will override sensor setpoint.

BUTTONS Key

	DHW temperature adjustment (+ to increase the temperature and - to decrease it)
	Heating water temperature adjustment (+ to increase the temperature and - to decrease it)
	Boiler operating information
	Operating mode: DHW – DHW & Heating – Heating Only
	Off – Reset – Exit menu/functions

Boiler Control Panel

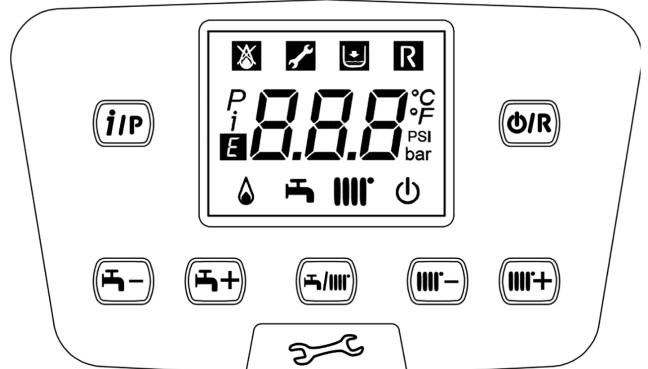



ACCESSORIES

2. 10k Ω Indirect Storage Tank Sensor Kit

Heating Only boiler can be electrically connected to Indirect Storage Tank.

Diagram of hydraulic connection of external indirect storage tank is shown below.

Connect DHW priority sensor to terminals 3 and 4 on terminal block M2. The element of the sensor must be inserted in the sensor well located on the indirect storage tank.

Verify the exchange capacity of the storage boiler coil is appropriate for power of the boiler. Adjust DHW temperature (+95°F...+140°F / +35°C...+60°C) by pressing   buttons on boiler control panel.



Parameter P03 for **Heating Only** boiler, with no indirect tank remains Factory Set at 08. No change is required.

If adding an Indirect Tank with a sensor to **Heating Only Boiler** - change P03 parameter from 08 to 05.

If adding an Indirect Tank with a thermostat to **Heating Only Boiler** - change P03 parameter from 08 to 04.

See Section 9, Parameter Settings, in boiler's Installation, Operation, and Maintenance Manual.

Parameter P03 for **COMBI** boiler factory set at 00 requires no change.

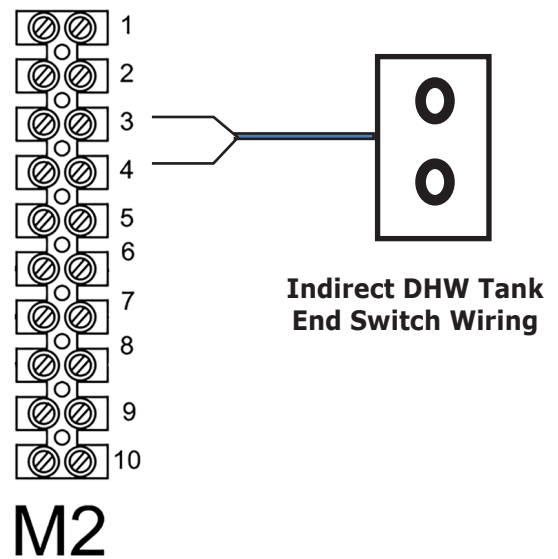
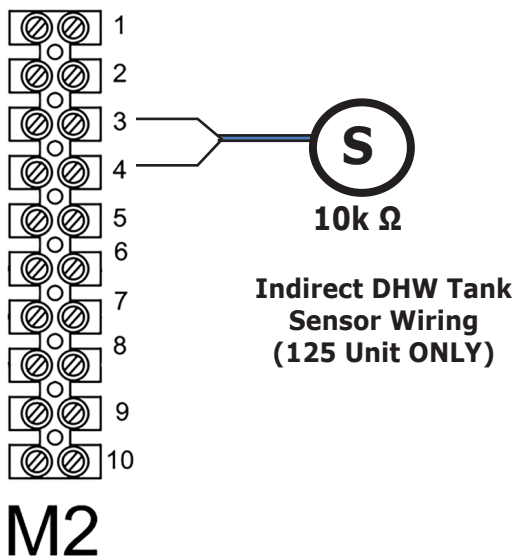

Management of 0-10V Input

The functions with 0...10V regulator are activated by means of their parameters. When the function is enabled (**P82=3**) and **P78=1**, the input manages the heating set point temperature directly; when **P78=2**, the input manages the heating power input directly. Demand is activated above 3V and the heating setpoint is calculated in proportion to deviation from 3 to 10 V DC, to give a setpoint that goes from minimum to maximum.

Voltage	P78=1		P78 = 2					
	Temp Setting		115		125/150		165/205	
	°C	°F	kW	MBH	kW	MBH	kW	MBH
0-3	OFF							
3	25	77	4.9	16.6	6.4	22.0	8.6	29.5
4	32	90	8.4	28.9	10.7	36.5	14.4	49.0
5	40	104	12.0	40.8	14.9	51.0	19.9	68.0
6	49	120	15.4	52.4	19.2	65.5	25.5	87.0
7	57	135	18.5	63.1	23.4	80.0	31.1	106.0
8	65	149	22.2	75.7	27.7	94.5	36.6	125.0
9	73	163	25.3	86.2	31.9	109.0	42.5	145.0
10	80	176	27.4	93.6	36.9	125.0	48.1	164.0

125 - HEAT ONLY WIRING DIAGRAM

MODEL 125 - Heat Only

24012599 REV B

- LEGEND - LEGENDES**
- 1-FUSES 3, 15 A - Fusibles 3, 15 A
 - 2-Supply 120V - 60Hz - Alimentation
 - 3-Fan - Ventilator
 - 4-Air pressure switch - Pressostat différentiel fumées
 - 5-Safety Thermostat - Thermostat de Sécurité
 - 6-Gas Valve - Vanne à gaz
 - 7-Exchanger sensor - Sonde échangeur
 - 8-Water Pressure Switch - Pressostat Eau
 - 9-MTC return sensor - Sonde MTC retour
 - 10-MTC flow sensor - Sonde MTC départ
 - 11-Flue Safety Thermostat - Thermostat Fumées
 - 12-Remote User Interface or Open Therm
 - 13-DMV Temperature sensor - Sonde température EDS
 - 14-Prov. for Outside Sensor - Pred. Sonde Extérieure
 - 15-Link 24V - Joint 24V
 - 16-Link 0 - 10V - Joint 0 - 10V
 - 17-Flame Sensing Electrode - Electrode présence veilleuse
 - 18-Ignition Electrode - Electrode d'allumage
 - 19-Three Way Valve - Soupape trois Voies
 - 20-Pump - Pompe
 - M1-Hot Power Terminal Board - Bornier d'alimentation
 - M2-Accessories Terminal Board - Bornier pour accessoires

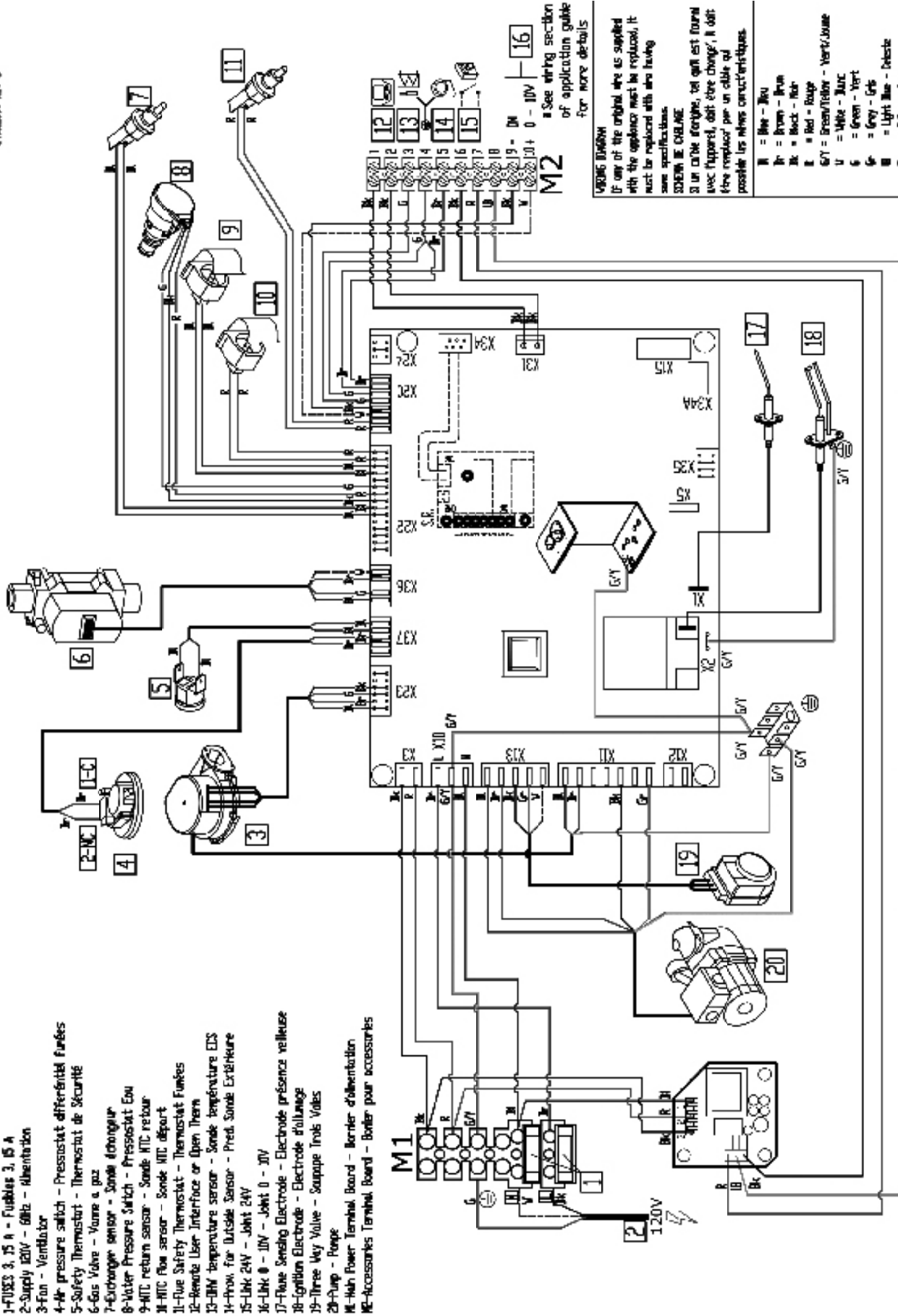

WARNING DANGER
 If any of the original wire is supplied with the appliance must be replaced, it must be replaced with wire having same specifications.
SEE THE CHART
 In an OTRM furnace, the gas vent must use copper, do not use change, it does the replacement use an cable of possible the same characteristics.

W = Wire - Fil
Bk = Brown - Brun
Blk = Black - Noir
R = Red - Rouge
GY = Green/Yellow - Vert/Jaune
W = White - Blanc
G = Green - Vert
Gr = Grey - Gris
LI = Light Blue - Bleu
Y = Yellow - Jaune

165 - HEAT ONLY WIRING DIAGRAM

MODEL 165 - Heat Only

24012666 REV B

LEGEND - LEGENDE

- 1-Fluse 3, 15 A - Fusibles 3, 15 A
- 2-Supply 120V - 60Hz - Alimentation
- 3-Fan - Ventilator
- 4-Safety Thermostat - Thermostat de Sécurité
- 5-Gas Valve - Vanne à gaz
- 6-Exchanger sensor - Sonde échangeur
- 7-Water Pressure Switch - Pressostat Eau
- 8-MTC return Sensor - Sonde MTC retour
- 9-MTC flow sensor - Sonde MTC départ
- 10-Flue Safety Thermostat - Thermostat Flue
- 11-Remote User Interface or Open Therm
- 12-Flue temperature sensor - Sonde température ECS
- 13-Prov. for Outside Sensor - Sond. Sonde Extérieure
- 14-Link 24V - Joint 24V
- 15-Link 0 - 10V - Joint 0 - 10V
- 16-Flame Sensing Electrode - Electrode présence veilleuse
- 17-Ignition Electrode - Electrode d'allumage
- 18-Pump - Pompe
- ME-Hot Power Terminal Board - Bornier d'alimentation
- RE-Accessories Terminal Board - Bornier pour accessoires

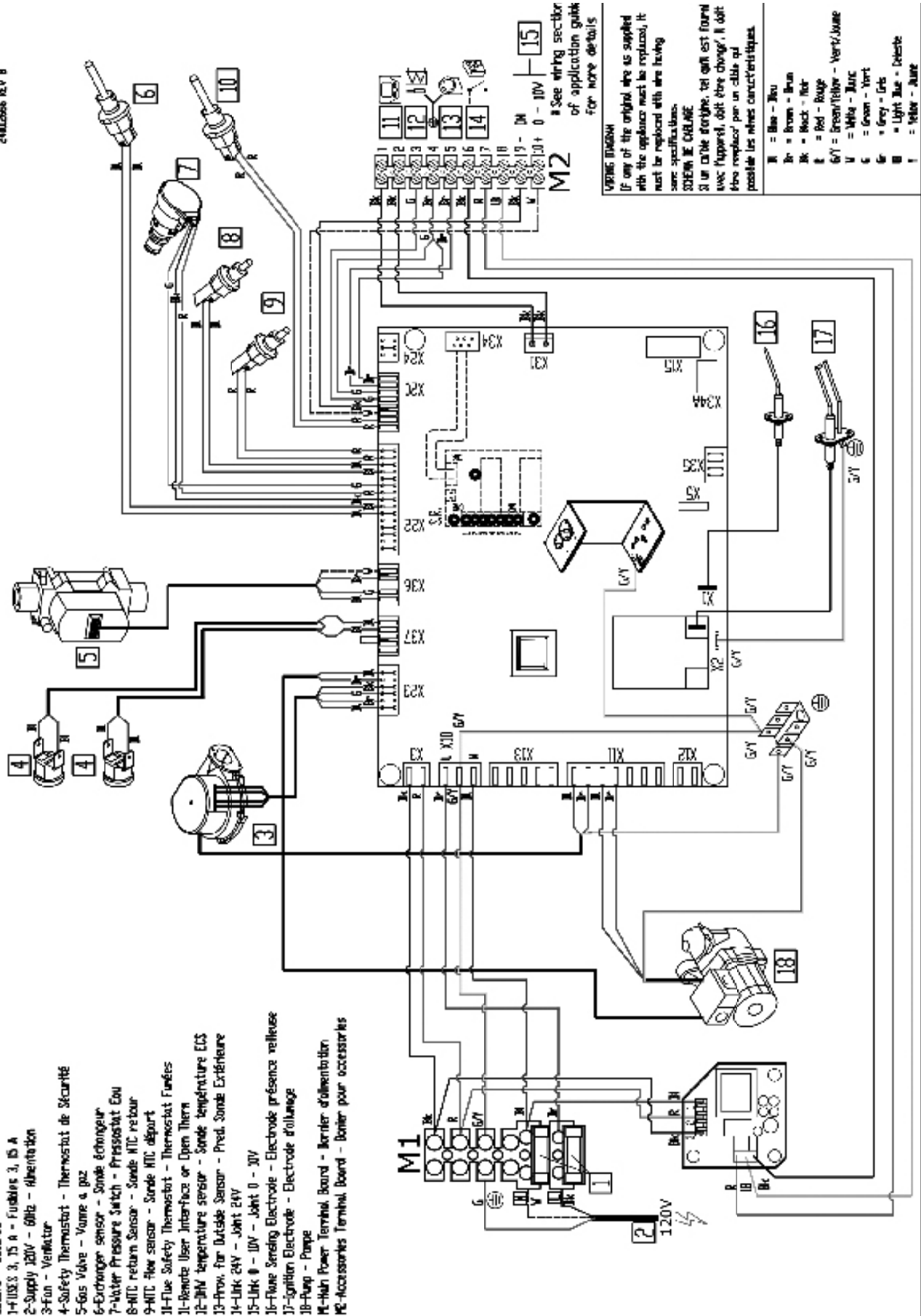

WIRING DIAGRAM
 If any of the original wire as supplied with the appliance must be replaced, it must be replaced with wire having same specifications.
SCHEMÉ DE CÂBLAGE
 Si un câble d'origine tel qu'il est fourni avec l'appareil doit être changé, il doit être remplacé par un câble qui possède les mêmes caractéristiques.

WIRE COLOR KEY
 B = Blue - Bleu
 Br = Brown - Brun
 Blk = Black - Noir
 R = Red - Rouge
 GY = Green/Yellow - Vert/Jaune
 W = White - Blanc
 Gr = Grey - Gris
 Lb = Light Blue - Bleu clair
 A = Yellow - Jaune

See wiring section of application guide for more details.

150 - COMBI WIRING DIAGRAM

MODEL 150 - Combi

240012700 REV A

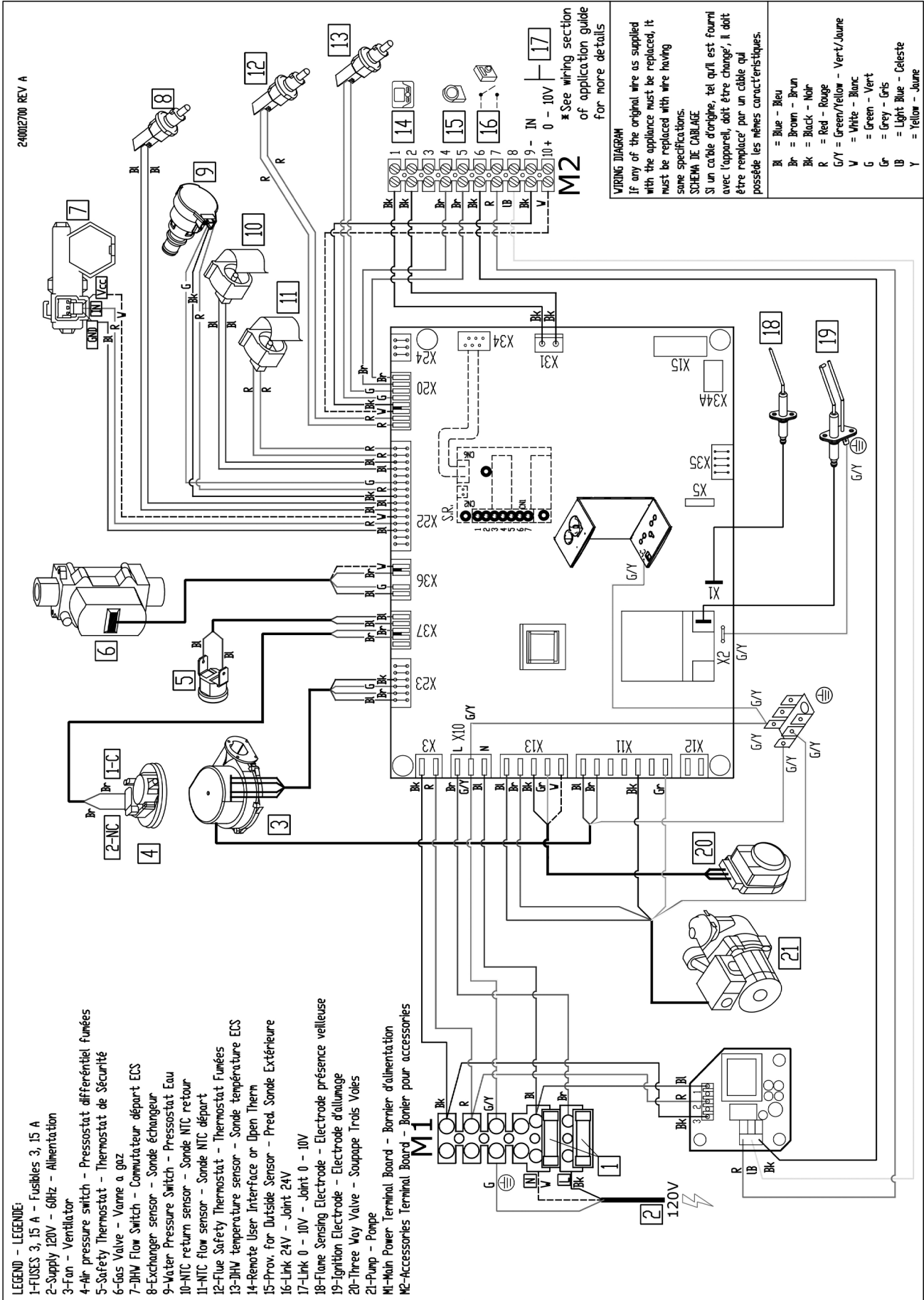

LEGEND - LEGENDE:

- 1-FUSES 3, 15 A - Fusibles 3, 15 A
- 2-Supply 120V - 60Hz - Alimentation
- 3-Fan - Ventilator
- 4-Air pressure switch - Pressostat différentiel fumées
- 5-Safety Thermostat - Thermostat de Sécurité
- 6-Gas Valve - Vanne à gaz
- 7-DHW Flow Switch - Commutateur départ ECS
- 8-Exchanger sensor - Sonde échangeur
- 9-Water Pressure Switch - Pressostat Eau
- 10-NTC return sensor - Sonde NTC retour
- 11-NTC flow sensor - Sonde NTC départ
- 12-Flue Safety Thermostat - Thermostat Fumées
- 13-DHW temperature sensor - Sonde température ECS
- 14-Remote User Interface or Open Therm
- 15-Prov. for Outside Sensor - Pred. Sonde Extérieure
- 16-Link 24V - Joint 24V
- 17-Link 0 - 10V - Joint 0 - 10V
- 18-Flame Sensing Electrode - Electrode présence veilleuse
- 19-Ignition Electrode - Electrode d'allumage
- 20-Three Way Valve - Soupape Trois Voies
- 21-Pump - Pompe
- M1-Main Power Terminal Board - Bornier d'alimentation
- M2-Accessories Terminal Board - Bornier pour accessoires

WIRING DIAGRAM

If any of the original wire as supplied with the appliance must be replaced, it must be replaced with wire having same specifications.
 SCHEMA DE CABLAGE
 Si un câble d'origine, tel qu'il est fourni avec l'appareil, doit être changé, il doit être remplacé par un câble qui possède les mêmes caractéristiques.

- Bk = Blue - Bleu
- Br = Brown - Brun
- Bk = Black - Noir
- R = Red - Rouge
- G/Y = Green/Yellow - Vert/Jaune
- V = White - Blanc
- G = Green - Vert
- Gr = Grey - Gris
- LB = Light Blue - Céleste
- Y = Yellow - Jaune

205 - COMBI WIRING DIAGRAM

MODEL 205 - Combi

240012701 REV A

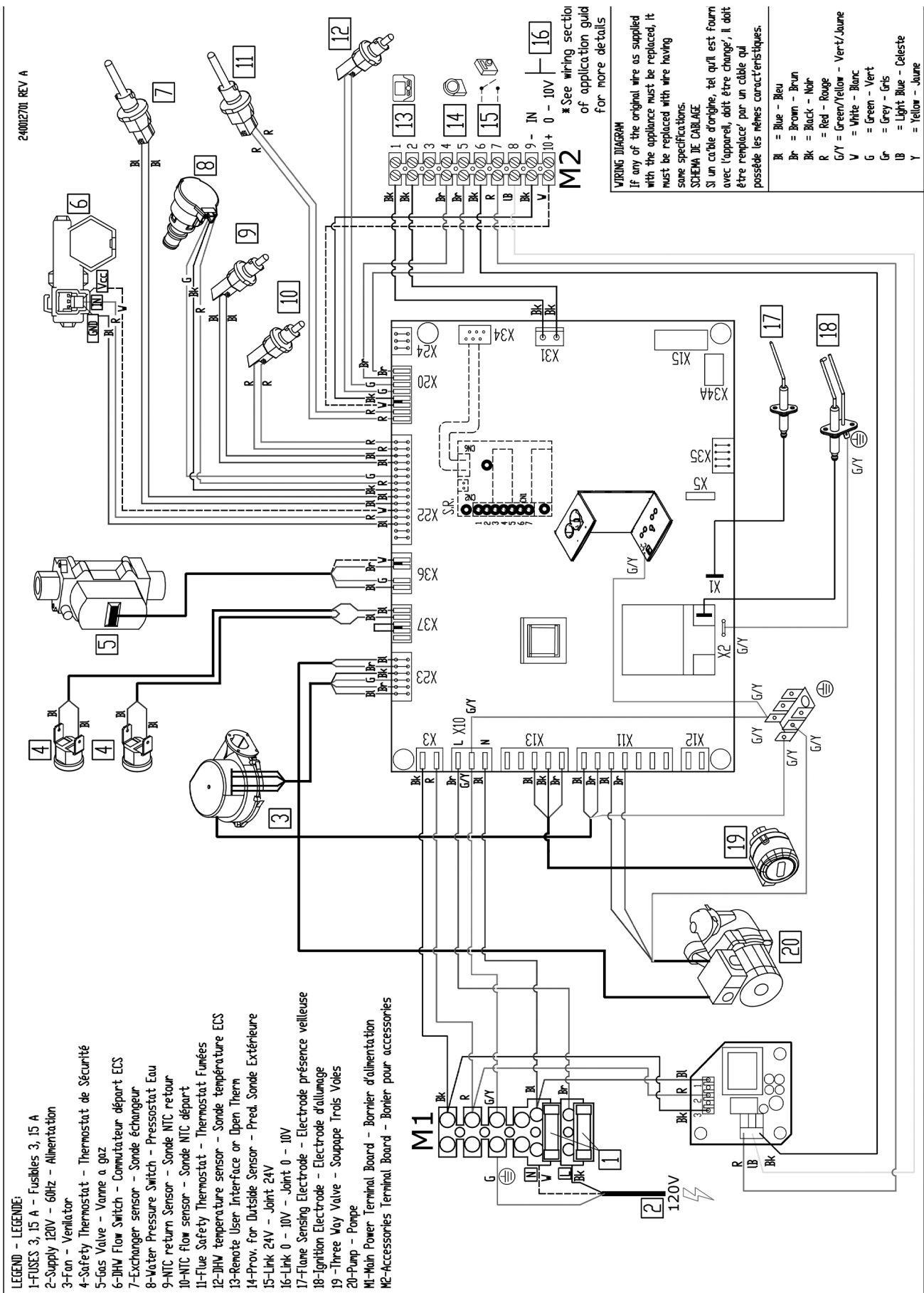

LEGEND - LEGENDE:

- 1-FUSES 3, 15 A - Fusibles 3, 15 A
- 2-Supply 120V - 60Hz - Alimentation
- 3-Fan - Ventilator
- 4-Safety Thermostat - Thermostat de Sécurité
- 5-gas Valve - Vanne a gaz
- 6-DHW Flow Switch - Commutateur départ ECS
- 7-Exchanger sensor - Sonde échangeur
- 8-Water Pressure Switch - Pressostat Eau
- 9-NTC return Sensor - Sonde NTC retour
- 10-NTC flow sensor - Sonde NTC départ
- 11-Flue Safety Thermostat - Thermostat Fumées
- 12-DHW temperature sensor - Sonde température ECS
- 13-Remote User Interface or Open Therm
- 14-Prov. for Outside Sensor - Pred. Sonde Extérieure
- 15-Link 24V - Joint 24V
- 16-Link 0 - 10V - Joint 0 - 10V
- 17-Flame Sensing Electrode - Electrode présence veilleuse
- 18-Ignition Electrode - Electrode d'allumage
- 19 -Three Way Valve - Soupape Trois Voies
- 20-Pump - Pompe
- M1-Main Power Terminal Board - Bornier d'alimentation
- M2-Accessories Terminal Board - Bornier pour accessoires

WIRING DIAGRAM

If any of the original wire as supplied with the appliance must be replaced, it must be replaced with wire having same specifications.

SCHEMA DE CABLAGE
Si un câble d'origine, tel qu'il est fourni avec l'appareil, doit être changé, il doit être remplacé par un câble qui possède les mêmes caractéristiques.

- Bk = Blue - Bleu
- Br = Brown - Brun
- Bk = Black - Noir
- R = Red - Rouge
- G/Y = Green/Yellow - Vert/Jaune
- V = White - Blanc
- G = Green - Vert
- Gr = Grey - Gris
- LB = Light Blue - Céleste
- Y = Yellow - Jaune

ALTITUDE EFFECTS ON BOILER PERFORMANCE

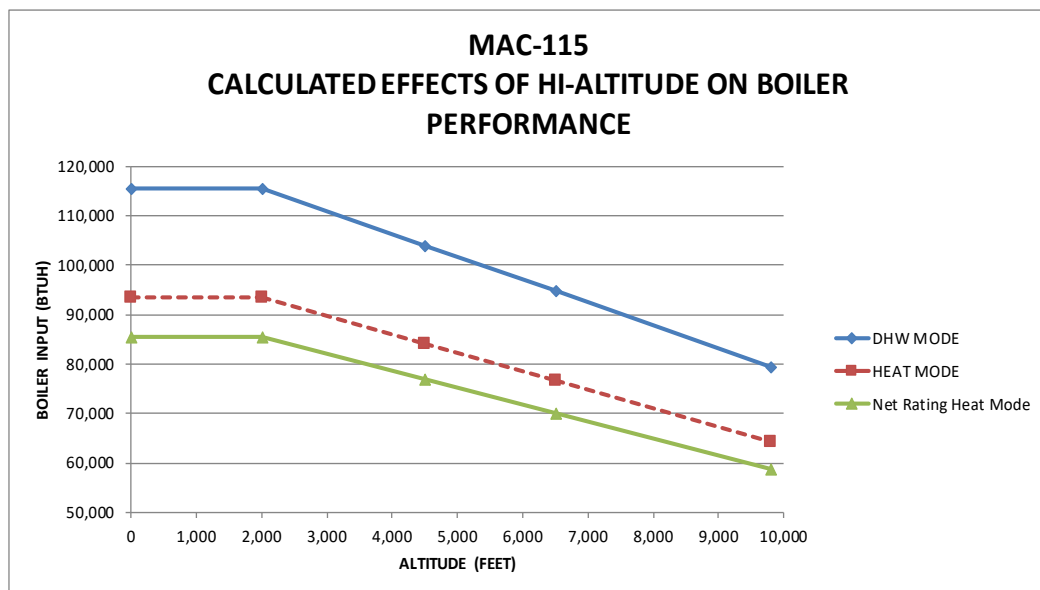
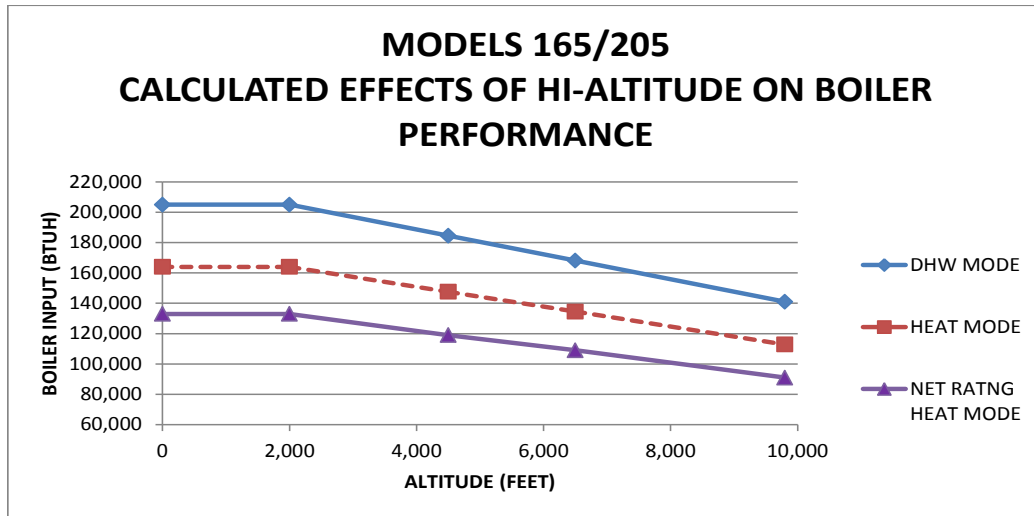
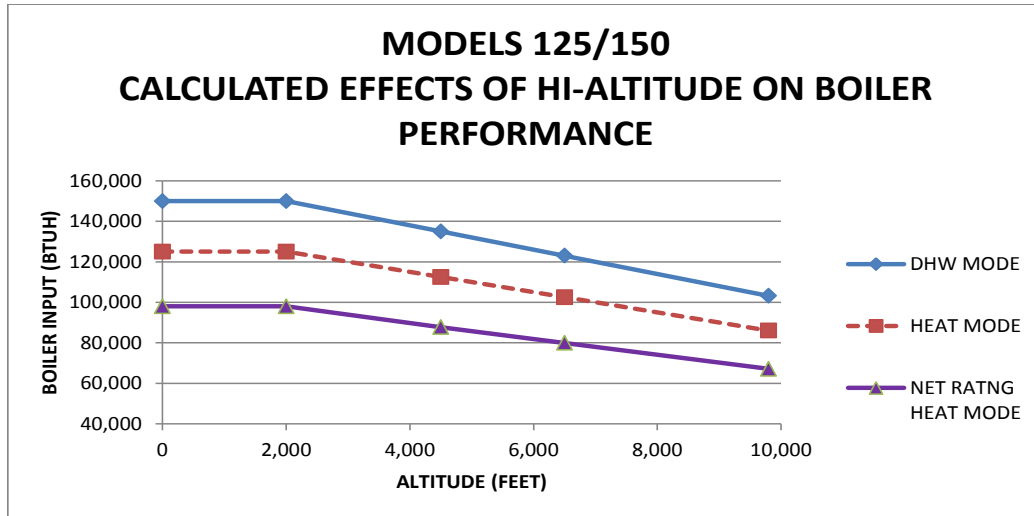

APPLICATION TABLE - INDIRECT TANK SIZING

'HEATING ONLY' BOILER (125,000 BTUH)

		BOILER OUTPUT (BTUH/HR)			
		50,000	60,000	80,000	100,000
H2O30					
1st HOUR RATING (GAL/HR)	140 F	94	106	106	106
	115 F	119	138	158	158
CONTINUOUS RATING (GAL/HR)	140 F	67	79	79	79
	115 F	92	111	131	131
H2O40 / H2O40L					
1st HOUR RATING (GAL/HR)	140 F	103	115	119	119
	115 F	128	147	174	174
CONTINUOUS RATING (GAL/HR)	140 F	67	79	83	83
	115 F	92	111	138	138
H2O50					
1st HOUR RATING (GAL/HR)	140 F	112	124	133	133
	115 F	137	156	192	192
CONTINUOUS RATING (GAL/HR)	140 F	67	79	88	88
	115 F	92	111	147	147
H2O60 / H2O60L					
1st HOUR RATING (GAL/HR)	140 F	121	133	147	147
	115 F	146	165	208	208
CONTINUOUS RATING (GAL/HR)	140 F	67	79	93	93
	115 F	92	111	154	154

Notes:

**176 °F Boiler Supply Water Temperature
 AHRI Rating Conditions - 50 °F Inlet Water
 @ 4.0 GPM FLOW RATE**

**Boiler output over 100,000 BTU does not effect
 tank performance.**

A - LOW WATER CUTOFF

Low Water Cut Off - Heating Only and Combi Boilers

These guidelines are supplied when necessary to install an additional Low Water Cut Off (LWCO), for sensing a low water level condition in a boiler, as required by the Authority Having Jurisdiction.

Follow LWCO manufacturer installation instructions for type of LWCO selected in addition to these instructions.

LWCO shall be 120V/60HZ control and dry contacts sized for load being connected. Wire control to boiler. See Figure 1.

Connect LWCO device to the system ground. Ground in accordance with the requirements of the authority having jurisdiction or, in the absence of such requirements, with the National Electrical Code (NEC) or Canadian Electrical Code CEC.

- Locate LWCO sensing device in the supply piping, above the minimum height of boiler. See Figure A-2, Piping Diagram.
- Position control in HORIZONTAL piping to assure proper boiler protection (upright or 90° rotation).
- For proper operation, sensing element of the LWCO control shall be positioned in the tee to sense the main water stream. Maintain minimum 1/4" spacing from pipe walls. Element shall NOT contact the rear, or side walls of the tee. See Figure A-3.
- Install an air vent using a tee to avoid nuisance shutdowns.
- Apply small amount of pipe sealant to threaded connections.
- Arrange piping to prevent water dripping onto boiler.
- DO NOT install water shutoff valve between boiler and LWCO sensing device.

LWCO Wiring Diagram

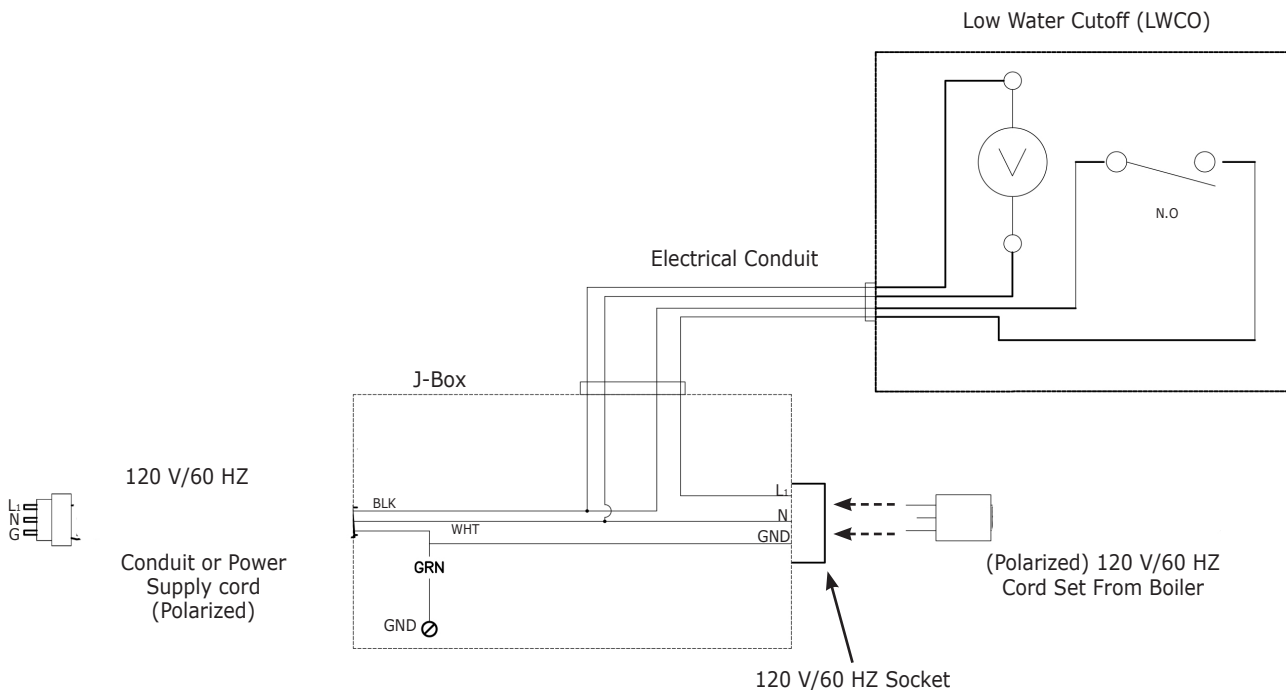

LOW WATER CUTOFF

Piping Diagram - LWCO Location

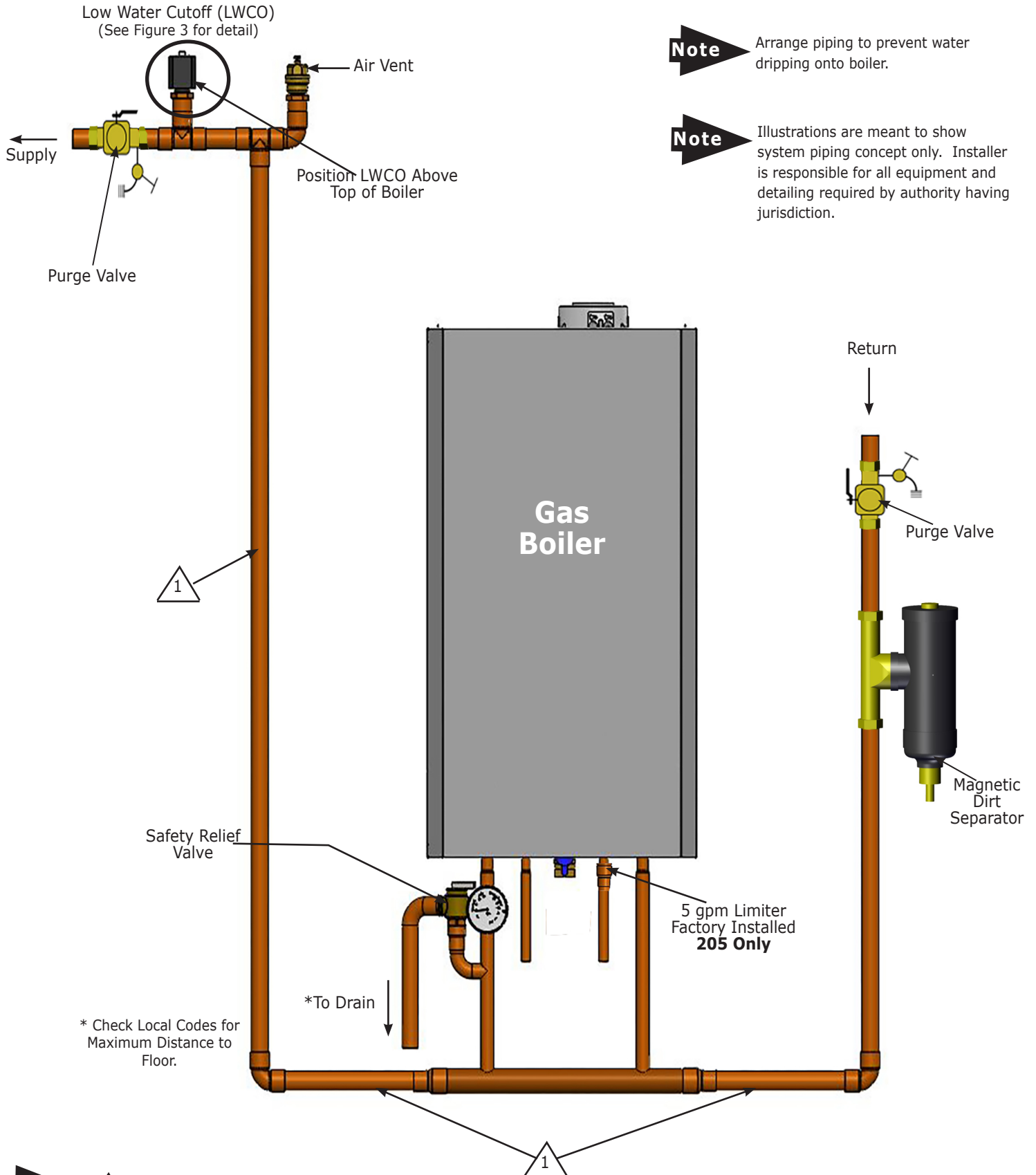

Note Arrange piping to prevent water dripping onto boiler.

Note Illustrations are meant to show system piping concept only. Installer is responsible for all equipment and detailing required by authority having jurisdiction.

Note **1** DO NOT PLACE ISOLATION VALVE BEFORE TEE OR LWCO.

LOW WATER CUTOFF

Low Water Cutoff - Detail

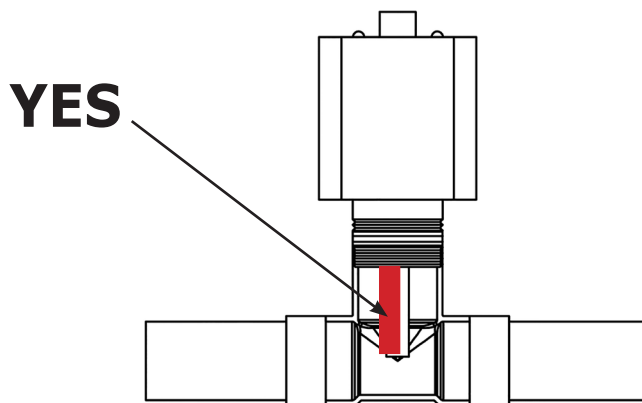
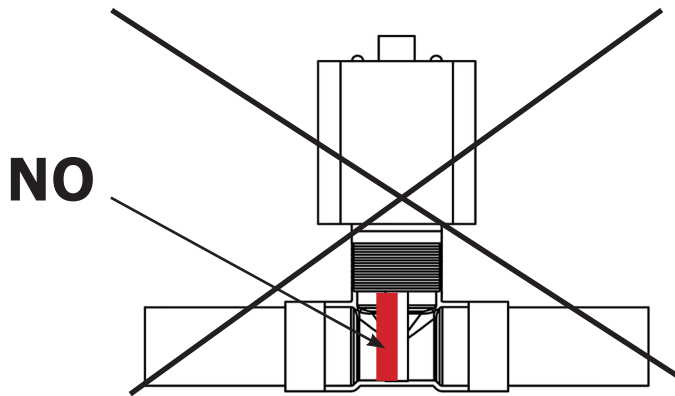
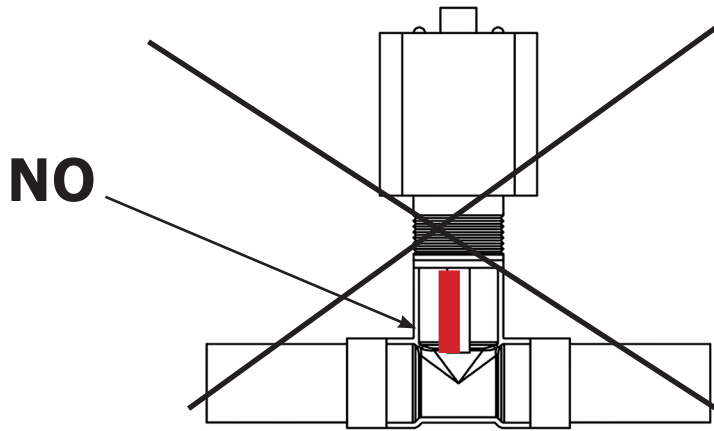

ERROR CODE TABLE

NOTE: When instructed press and hold the 'Reset' for between 1-3 seconds to reset the boiler.

Table Of Error Codes

E 09	Gas valve connection cable
E 10	External probe fault
E 12	Water flow switch open
E 13	Water flow switch close
E 15	gas valve fault
E 18	Water refill enabled
E 19	Max time of water refill
E 20	Central Heating Flow NTC Fault
E 28	Flue NTC Fault
E 40	Central Heating Return NTC Fault
E 50	Hot Water NTC Fault (tank version)
E 53	Obstruction on the flue pipe- combustion off
E 55	PCB to be set by the "Calibration Function"
E 71	Fan parameter Out of range in autocalibration
E 72	Combustion test Out of range in autocalibration
E 77	Current out of range
E 78	Minimum gas valve current
E 79	Maximum gas valve current
E 83-87	Communication error
E 92	Combustion test alarm during auto-setting
E 109	Pre-Circulation Fault
E 110	Safety Thermostat Operated
E 117	System Water Pressure Too High
E 118	System Water Pressure Too Low
E 125	Circulation Fault (Primary Circuit)
E 128	Flame Failure
E 129	Frequently loss of flame during the ignition
E 130	Flue NTC Operated
E 133	Interruption Of Gas Supply or Flame Failure
E 134	Elapsed time Gas valve open without gas
E 135	Interruption Of Gas Supply (internal error)
E 160	Fan or Fan Wiring Fault
E 321	Domestic Hot Water NTC sensor fault
E 384	False flame
E 385	Under voltage

Initial Fault Finding Checks

1. Check that gas, water and electrical supplies are available at the boiler.
2. Electrical supply = 120V ~60 Hz.
3. The preferred minimum gas pressure is 3.5"wc for Natural gas and 10"wc for LPG.
4. Carry out electrical system checks, i.e. Ground Continuity, Resistance to Ground, Short Circuit and Polarity with a suitable meter.

NOTE: These checks must be repeated after any servicing or fault finding.

5. Ensure all external controls are calling for heat and check all external and internal fuses. Before any servicing or replacement of parts, ensure the gas and electrical supplies are isolated.

1. If a fault occurs on the boiler an error code may be shown by the facia display.

E 20, E 28, E 40, E 50, E 160, E 321 and E 431 indicate possible faulty components.

E 53 shows possible obstruction in the flue duct.

E 55 indicates that the pcb is not setting/calibrated.

E 71, E 72, E 77, E 78 e E 92 indicate possible wrong calibration. A new calibration is needed.

E 92 shows possible flue recirculation in the flue duct.

E 83...87 shows possible error of communication with thermostat (Goto section P)

E 110 shows overheat of the primary.

E 117 is displayed when the primary water pressure is more than 43 psi.

E 118 is displayed when the primary water pressure is less than 7.25psi.

E 125 is displayed in either of two situations:-

- i) If within a time between 15..30 seconds of the burner lighting the boiler temperature has not changed by 2°F.
- ii) If within 10 minutes of the burner lighting the boiler temperature twice exceeds the selected temperature by 80°F. In these instances poor primary circulation is indicated.

E 128 is displayed if there has been a flame failure during normal burner operation.

E 133 , E 134 and E 135 indicate that the gas supply has been interrupted, ignition has failed or the flame has not been detected.

2. By pressing the 'Reset' button for between 1-3 seconds when E 110, E 125, E 133, E 134, E 135, E 09, E 15, E 128 and E 384 are displayed it is possible to relight the boiler.

3. If this does not have any effect, or error codes are displayed regularly further investigation is required.

TROUBLESHOOTING CHART

Central Heating

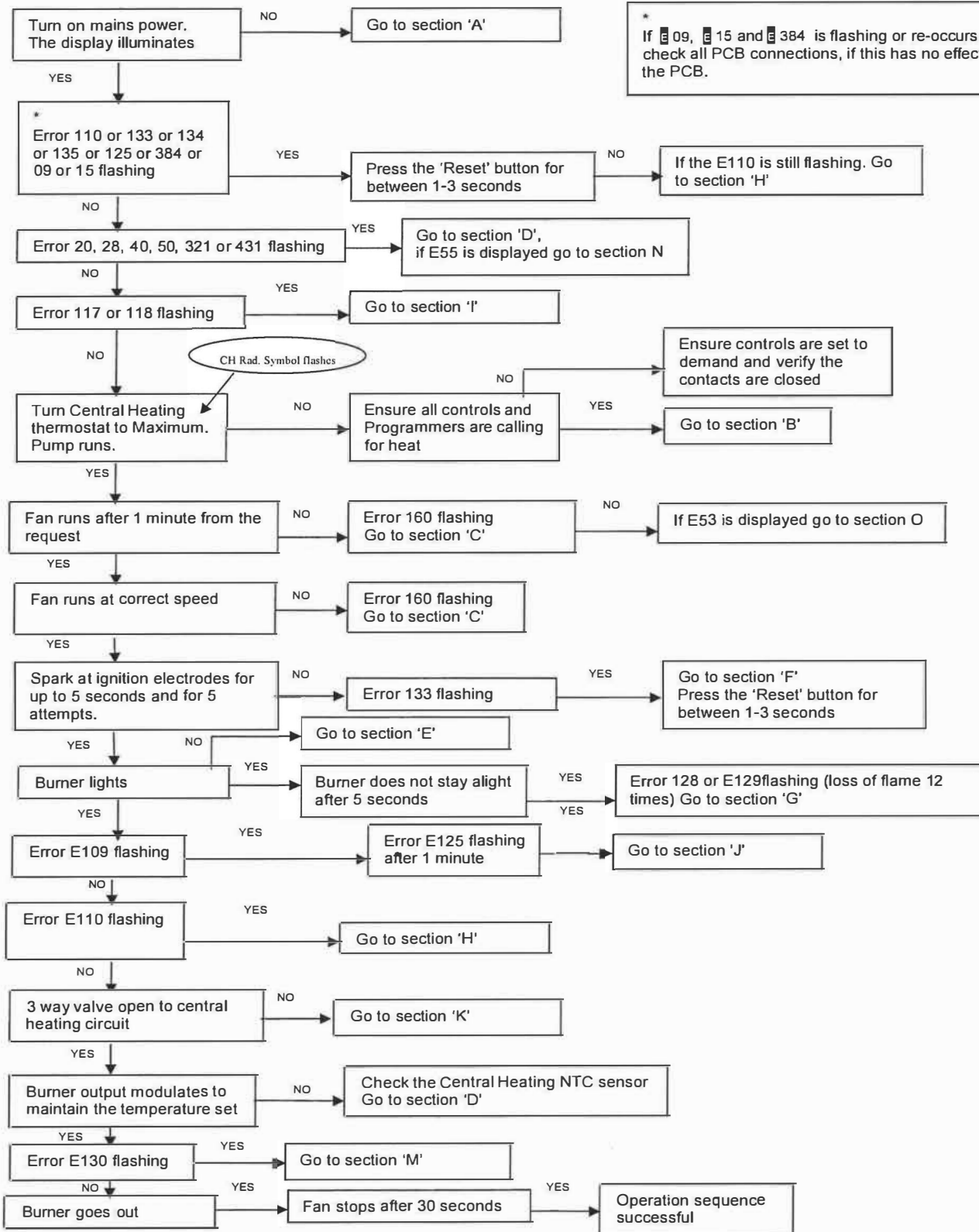

* If E09, E15 and E384 is flashing or re-occurs regularly check all PCB connections, if this has no effect replace the PCB.

TROUBLESHOOTING CHART

domestic hot water

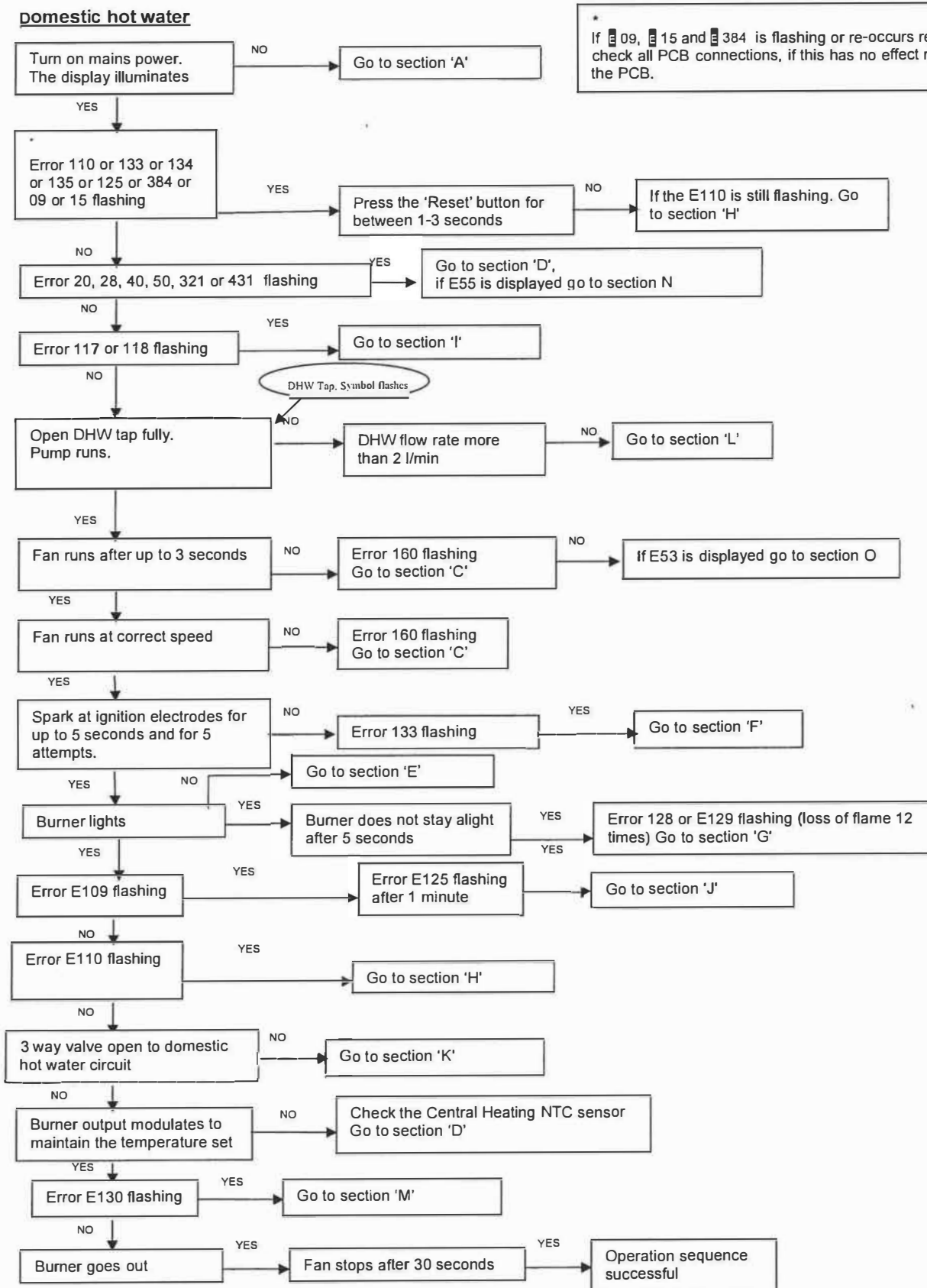

Fault Finding Solutions Sections

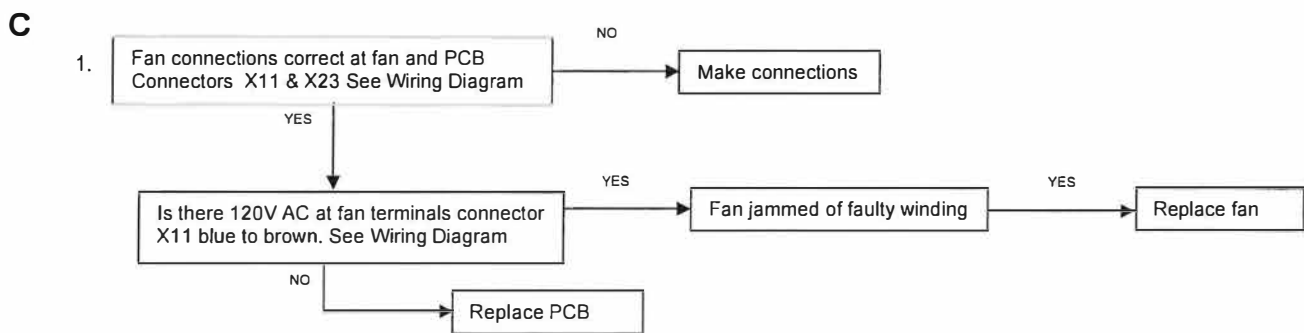
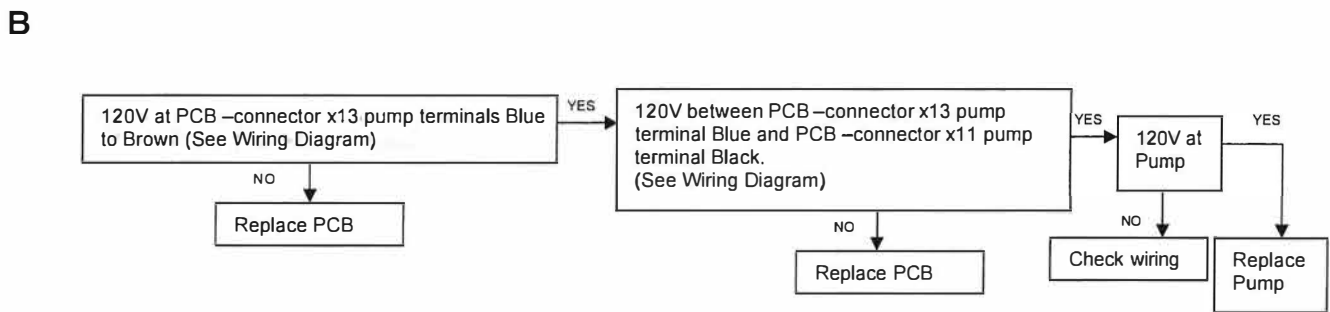
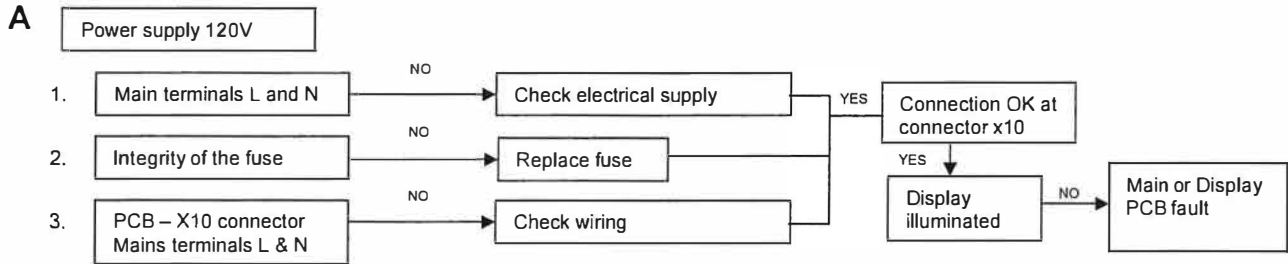

FAULT SOLUTION SECTIONS

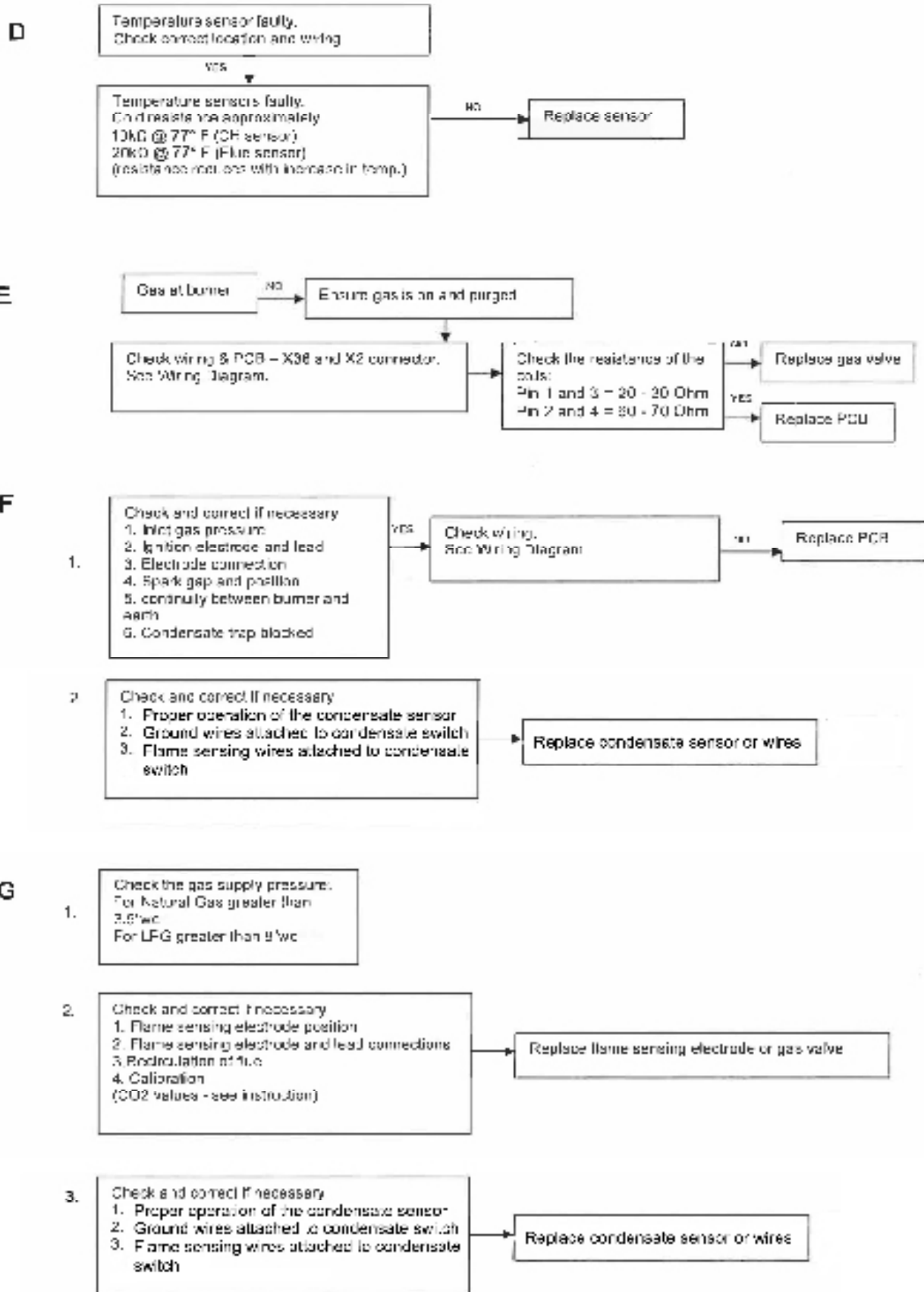

FAULT SOLUTION SECTIONS

H

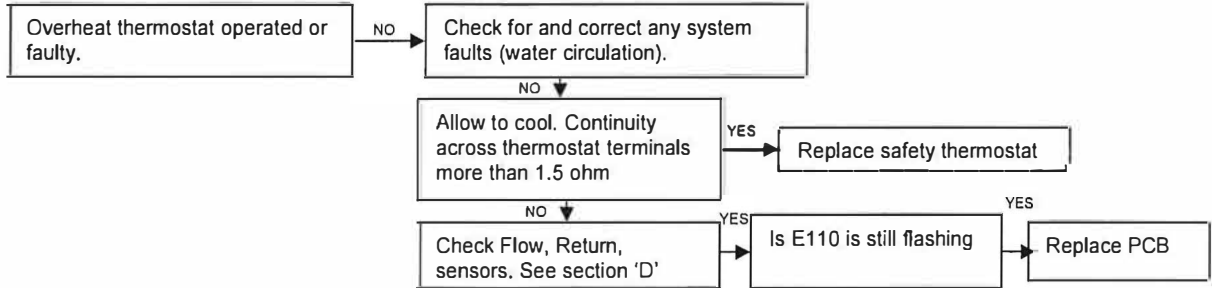

I

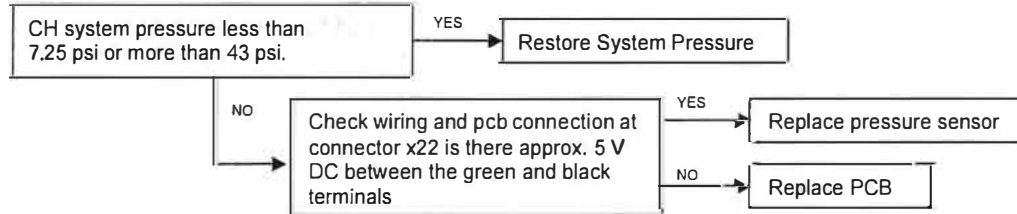

J

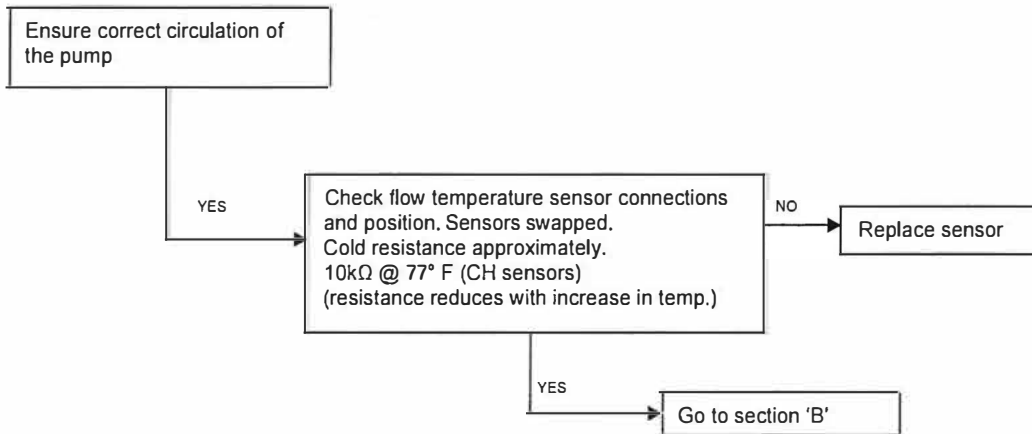

K

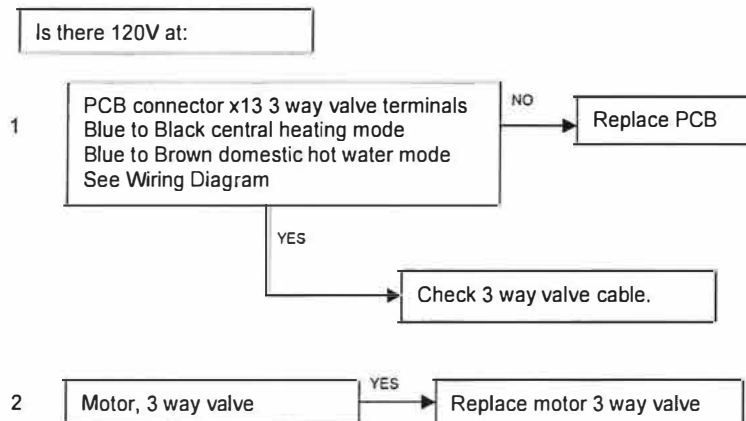

FAULT SOLUTION SECTIONS

L

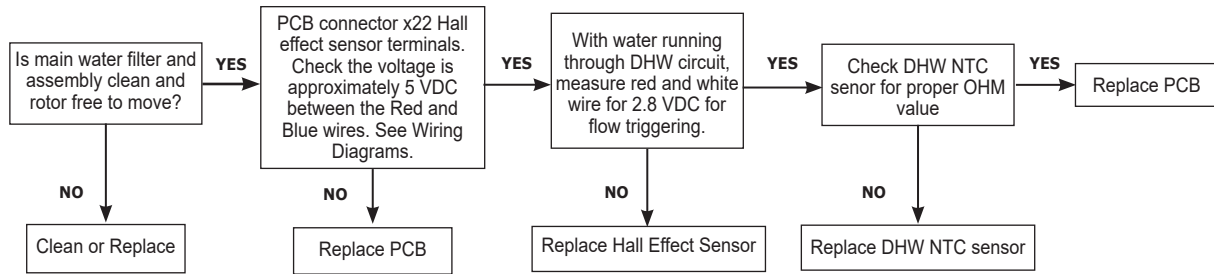

M

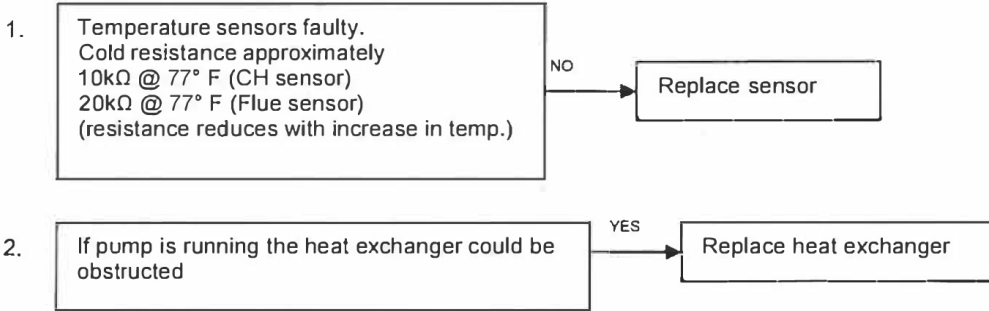

N

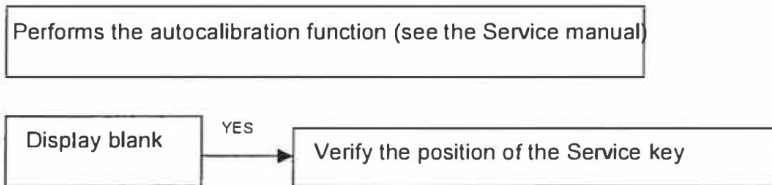

O

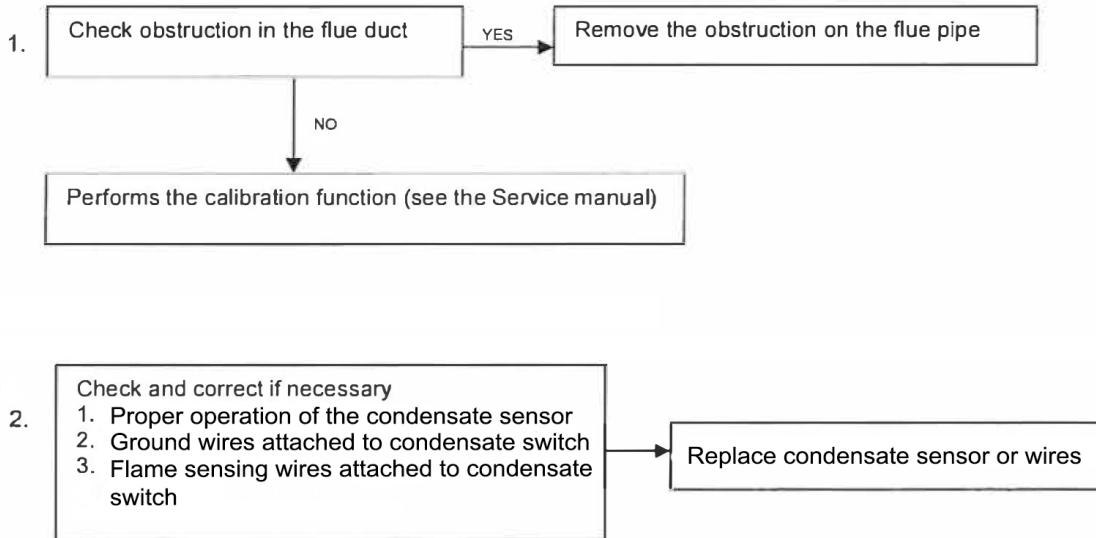

P

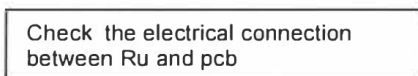



2201 Dwyer Avenue, Utica, NY
13501 Tel. 800 325 5479
www.ecrinternational.com

All specifications subject to change without notice.
©2020 ECR International, Inc.