

SMARTER & EASIER
WITH 95% AFUE
EFFICIENCY

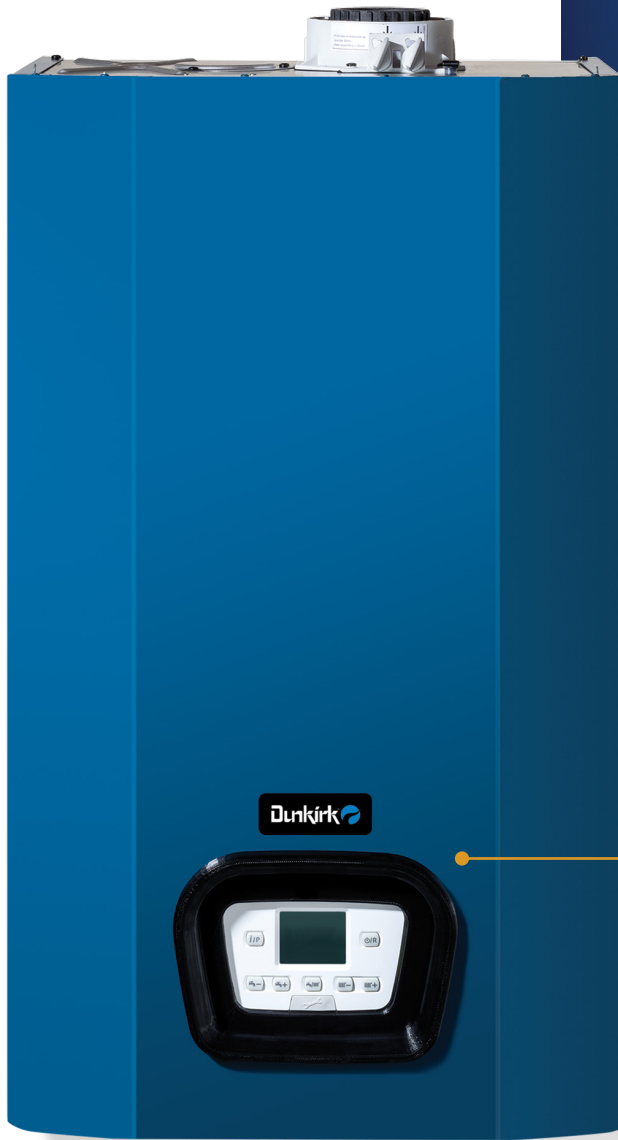

CONDENSING BOILERS

DCC COMBI
DCB HEATING

with ARTIFICIAL INTELLIGENCE **[AI]**



[AI] CONTROL

Self-Monitoring
Self-Adjusting
Self-Commissioning*

* Simply press two buttons to set up combustion.
Analyzer not required, but recommended.

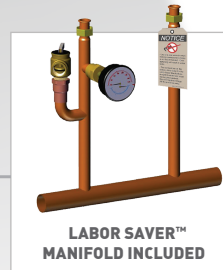

Dunkirk®

Innovative. Efficient. Dependable. Dunkirk.

www.dunkirk.com   



*Unit must be registered within 60 days from the date of original installation.
All terms of Trinity Extended Service Agreement apply.

PN 240011408 Rev. FM [2/7/2019]



Added protection for you and your family.

SMART CHOICE. [for contractors and homeowners]

INTELLIGENT TECHNOLOGY

The DCC is an intelligent condensing approach to residential heat and domestic hot water.



The Dunkirk High Efficiency Condensing Boiler uses [AI] Control Technology. The [AI] Control self commissions and continuously calibrates to ensure clean burning and optimum efficiency.

The [AI] Control measures water temperature, flue gas temperature, flame signal, and pressure that can impact the boiler operation and CO levels. The [AI] Control will automatically shut down operation should these values exceed normal operating levels. This provides added protection for you and your family.

Dunkirk prides ourselves on safety. Though the [AI] Control indirectly monitors CO levels and acts accordingly, it is not a replacement for a CO Detector in your home.

[AI] CONTROL

- Digital Control with Graphic Display • Boiler Status • Temperature Display
- Diagnostics • Automatically Adjusts for Fuel Type and Continuous Calibration

MODULATING TECHNOLOGY

The **[AI]** Control **automatically modulates** the gas input to the burner.

During times when the domestic hot water or heating demand is high, the control increases the amount of gas in order to meet the requirement. During times when the load demand is less, the **[AI]** Control decreases the gas input to **only use the amount of fuel necessary.**

Self**MONITORING**
Self**ADJUSTING**
Self**COMMISSIONING**] **OPTIMUM EFFICIENCY**

[AI] modulation **saves energy** by reducing the amount of gas used. Homeowners enjoy comfort, energy savings, and **lower utility bills.**

Everyone enjoys the comfort.

- **Homeowners** enjoy comfort, energy savings, and lower utility bills.
- **Contractors** enjoy the comfort of satisfied customers.



REFER TO SPECIFICATIONS FOR CAPACITY AND FIRING RATE INFORMATION.

DID YOU KNOW...

...that the typical gas-fired water heater is wasting energy by constantly maintaining the temperature of the water in the tank?

It's true. So why spend money continually heating water that you're not even using? There is a better modern solution when replacing your heating boiler. Consider a DCC combination boiler or, "combi boiler."

The benefits of the DCC combi boiler include:

- the highest efficiency level at 95% AFUE.
- space savings/wall mounted.
- the ability to both heat your home as well as provide your domestic hot water needs.
- eliminates the wasted energy associated with traditional gas water heaters.
- **MONEY SAVINGS.** By automatically modulating the gas input to the heating level that is needed, the boiler system operates at optimum efficiency, resulting in savings for you.

The DCC combi boiler provides both your home heating needs and your domestic hot water needs in one super-efficient on-demand appliance.

AT A **GLANCE...**

MODELS:

DCC205 **DCC150**
DCB165 **DCB125**

- 95% AFUE
- Featuring **[AI]** Control Technology
 - Recognizes Natural or LP Gas
 - No field conversion kit required
 - Self-Monitors and adjusts for fuel savings
 - Automatic Commissioning Combustion
- 7:1 Turndown Modulation Ratio in DHW Mode
- 5.5:1 Turndown Modulation Ratio in Heating Mode
- Primary/Secondary **LABOR SAVER™** Manifold Included
- **Warranty Coverage**
 - FREE 2-Year Parts & Labor Limited Warranty*
 - 10-Year Limited Heat Exchanger
- **Innovative American Manufacturing**

EXCEPTIONAL **SUPPORT**

When it comes to support, Dunkirk offers service that's beyond compare.

Our US-based support team is here for you AND your customers.

Our **Dealer Portal** offers a variety of resources, including tutorial videos and product specifications to help you every step of the way, from installation to maintenance to repair.



TAKE ADVANTAGE OF
REBATES
WITH 95% AFUE



LABOR SAVER™ MANIFOLD



SAVE TIME & INCREASE PRODUCTIVITY with our **LABOR SAVER™ MANIFOLD**.

Dunkirk condensing boilers come with a **FREE LABOR SAVER™ MANIFOLD, WARRANTY**, and **SUPPORT** matched by no other manufacturer.

*Unit must be registered within 60 days from the date of original installation. All terms of Trinity Extended Service Agreement apply.

A CLOSER LOOK...

COMBI MODEL

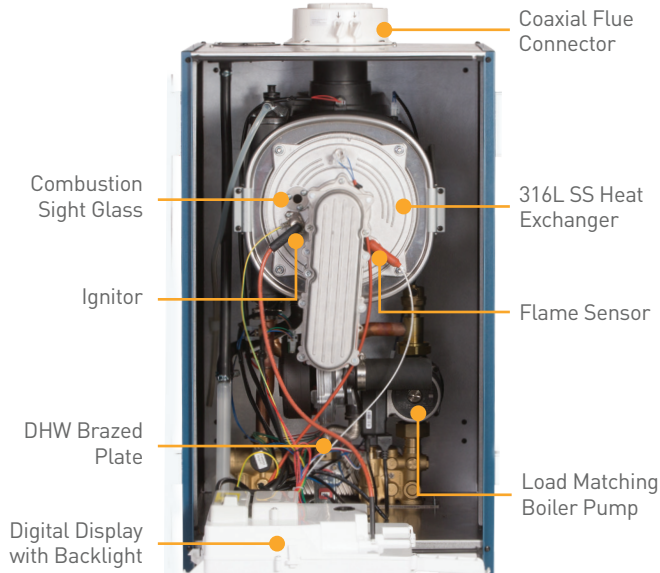

HEATING ONLY MODEL

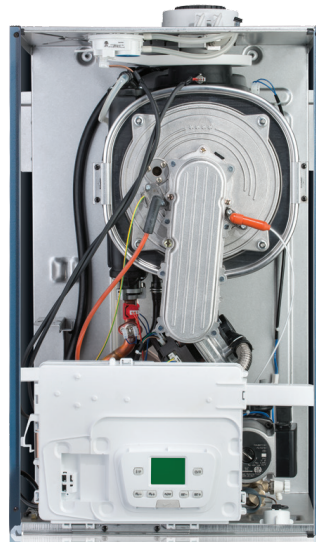

- Auto Commissioning and Continuous Calibration functions optimize combustion and result in lower fuel bills
- Features 316L Stainless Steel Heat Exchanger and Burner
- Features such as, high limit sensors, pressure relief valve, low water sensor, and system pressure gauge ensure safety and top performance of the unit
- Control Panel features a backlit digital display that indicates boiler status, temperature, and diagnostics
- Preheat function
- Built in load matching Pump contributes to savings in electrical usage



HEATING MODEL WITH OPTIONAL INDIRECT HOT WATER HEATER

Our [AI] control is programmed to recognize an indirect tank, with no need for a separate relay. Dunkirk H2O Indirect Hot Water Heaters are available in 30 to 115 gallon capacities and feature 316L stainless steel construction and top connections for an easy installation.

STANDARD EQUIPMENT

Heat Exchanger: 316L Stainless Steel Burner. DCC-205 and DCC-165 are also equipped with a stainless steel brazed plate heat exchanger

Primary/Secondary LABOR SAVER™ Manifold

Boiler Control Module: High Limit/Electronic Ignition Control

User Display Interface: Digital Temperature Display with diagnostics and programmable settings

Adaptive Combustion: Automatically modulating gas valve with 5.5:1 Turndown for Heating Mode and 7:1 for DHW Mode. Stainless Steel Burner, Direct Spark Ignition, Separate Flame Sensor, 100% shutoff

Other: Assembled Boiler with Jacket, Induced Draft Fan, High limit sensors, 30psi Relief Valve, Low Water Pressure Switch, and Temperature/Pressure Gauge. Built-in Load Matching Pump



LABOR SAVER™ MANIFOLD INCLUDED

LEARN MORE!

You can learn more about the DCC/DCB and our full line of products, services, training and support by visiting our website, or check out our Facebook page.

www.dunkirk.com



OPTIONAL EQUIPMENT:

Outdoor Temperature Sensor, Indirect Tank Sensor, Floor Stand Kit



SHOWN ON
OPTIONAL
FLOOR STAND.



INDIRECT
TANK SENSOR



OUTDOOR TEMPERATURE
RESET

PHYSICAL DATA

PRODUCT DIMENSIONS

DIMENSIONS	125 & 150	205 & 165
A HEIGHT	30" [763mm]	30" [763mm]
B WIDTH	17 3/4" [450mm]	17 3/4" [450mm]
C DEPTH	13 9/16" [345mm]	21 1/2" [571]
D CONDENSATE TRAP CONNECTION	13/16" [21mm] ID Hose	3/4" [19.1mm] NPT
E SYSTEM SUPPLY	3/4" [19.1mm]	1" [25.4mm]
F DHW OUTLET (125 OPTIONAL)	1/2" [15.9mm]	3/4" [19.1mm]
G GAS CONNECTION	3/4" 19.1mm	3/4" [19.1mm]
H DHW (COLD WATER) INLET	1/2" [15.9mm]	3/4" [19.1mm]
I SYSTEM RETURN	3/4" 19.1mm	1" [25.4mm]
J BOILER FILLING CONNECTION	1/2" [15.9mm]	External to Boiler
PRIMARY WATER CONTENT	1 gal [3.60L]	1 1/4 gal [4.73L]

FRONT VIEW
ALL MODELS

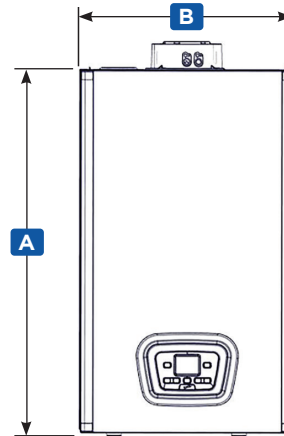

TOP VIEW
ALL MODELS

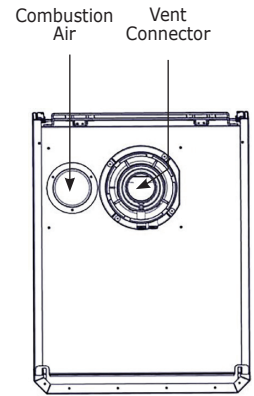

BOTTOM VIEWS

125 HEAT-ONLY

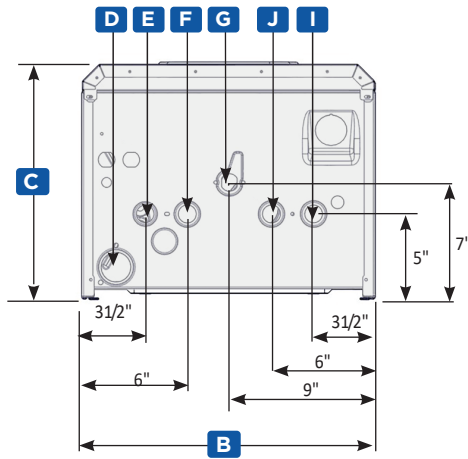

150 COMBI

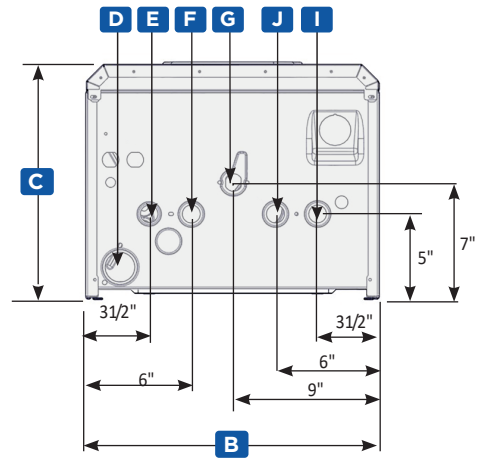

165 HEAT-ONLY

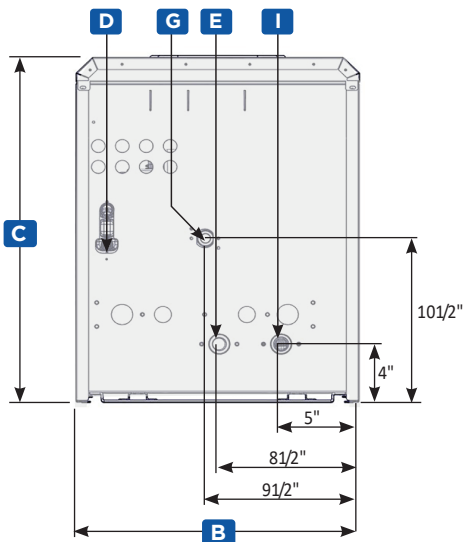

205 COMBI

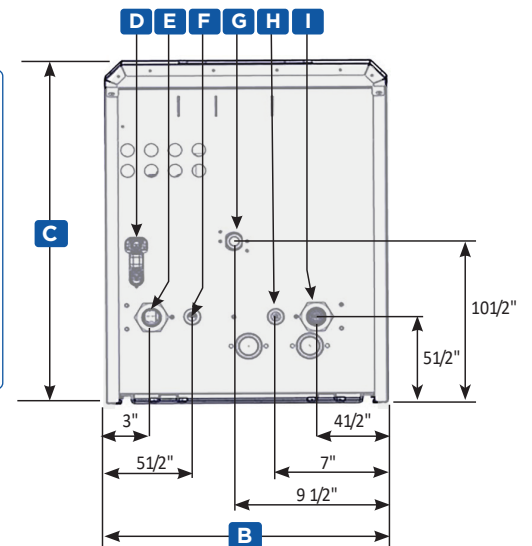

PRODUCT SPECIFICATIONS

IN DOMESTIC HOT WATER MODE

MODEL	INPUT MBH		FLOW RATE (Based on 70° Temperature rise)
	MAX	MIN	Gallons per minute
	COMBI DCC-150	153	22
DCC-205	205	29.5	5.0

IN SPACE HEATING MODE

MODEL	INPUT MBH		AHRI CERTIFIED RATINGS		
	MAX	MIN	Heating Capacity MBH	Efficiency AFUE %	Net Water MBH ⁽¹⁾
	COMBI DCC-150	125	22	113	95
DCC-205	164	29.5	153	95	133
HEAT ONLY DCB-125	125	22	113	95	98
DCB-165	164	29.5	153	95	133

(1) Net Water Rating shown based on piping and pickup allowance of 1.15. Consult manufacturer before selecting boilers for installation having unusual piping and pickup requirements, such as intermittent system operation, extensive piping systems, etc.

VENT MATERIAL / SIZE In Inches (mm)

MODEL	COAXIAL ⁽²⁾	2-PIPE POLYPROPYLENE ⁽²⁾		2-PIPE CPVC ⁽²⁾
		Inches	Inches	Inches
COMBI DCC-150	2/4" (60mm/100mm)	3"	3"	3"
DCC-205	3/5" (80mm/125mm)	2" or 3"	2" or 3"	2" or 3"
HEAT ONLY DCB-125	2/4" (60mm/100mm)	3"	3"	3"
DCB-165	3/5" (80mm/125mm)	2" or 3"	2" or 3"	2" or 3"

(2) Refer to IOM and vent pipe manufacturer's instructions for equivalent lengths and approved venting materials

BOILER CLEARANCES

DIMENSION	Combustible Materials ⁽³⁾	Manufacturer Recommended for SERVICE ^{(3) (4)}
TOP	0" (0cm)	8-5/8" (220mm)
LEFT	1-3/4" (45mm)	1-3/4" (45mm)
RIGHT	1-3/4" (45mm)	1-3/4" (45mm)
FRONT	0" (0cm)	17-3/4" (450mm)
BACK	0" (0cm)	0" (0cm)
BOTTOM	0" (0cm)	*9-13/16" (250mm)
COMBUSTION AIR/VENT PIPING	0" (0cm)	6" (160mm)

(3) Required distance measured from boiler jacket.

(4) Service, proper operation clearance recommendation.

* Allowance for piping at the bottom of the boiler not included.

CERTIFICATIONS

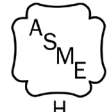

2201 Dwyer Avenue, Utica, NY 13501
Tel. 800.253.7900
www.ecrinternational.com

All specifications subject to change without notice.

© 2019 ECR International, Inc.

PN 240011408 Rev. FM [2/7/2019]