

INSTRUCTIONS
FOR
MULTIPLE
HOT WATER BOILER
INSTALLATIONS
UP TO 8 UNITS

Technical Support @ 800-325-5479
Phone: (315) 797-1310 • Fax: (866) 432-7329
e-mail: info@ecrinternational.com
web site: www.ecrinternational.com

Information and specifications outlined in this manual in effect at the time of printing of this manual. Manufacturer reserves the right to discontinue, change specifications or system design at any time without notice and without incurring any obligation, whatsoever.

P/N 240010851, Rev. B [11/2014]

SAFETY INFORMATION

WARNING

Fire, explosion, asphyxiation and electrical shock hazard. Improper installation could result in death or serious injury. Read this instruction and individual boiler's Installation, Operation & Maintenance Manual and understand all requirements, including requirements of authority having jurisdiction, before beginning installation. Installation not complete until appliance operation verified per Installation, Operation & Maintenance Manual provided with each boiler.

Installation shall be performed by a qualified service agency.

This instruction shall be used in conjunction with each unit's Installation, Operation and Maintenance Manual.

Installation shall conform to requirements of authority having jurisdiction or in absence of such requirements:

- United States
 - National Fuel Gas Code, ANSI Z223.1/NFPA 54.
 - National Electrical Code, NFPA 70.
- Canada
 - Natural Gas and Propane Installation Code, CAN/CSA B149.1.
 - Canadian Electrical Code, Part I, Safety Standard for Electrical Installations, CSA C22.1

CAUTION

WHAT TO DO IF YOU SMELL GAS

- Do not try to light any appliance.
- Do not touch any electrical switch; do not use any phone in your building.
- Immediately call your gas supplier from a neighbor's phone. Follow gas supplier's instructions.
- If you cannot reach your gas supplier, call the fire department.

Installations for Oil Burning Equipment shall conform to requirements of authority having jurisdiction or in absence of such requirements to ANSI/NFPA 31. In Canada, Current Edition of Canadian Standards Association CSA B139, Installation Code for Oil Burning Equipment" for recommended installation practices.

Where required by authority having jurisdiction, installation shall conform to Standard for Controls and Safety Devices for Automatically Fired Boilers, ANSI/ASME CSD-1.

Additional manual reset low water cutoff may be required.

Boiler installation must conform to Commonwealth of Massachusetts code 248 CMR which includes but is not limited to installation by licensed plumber or gas fitter.

Table of Contents

Safety Information	2
Typical Layouts For Hot Water Heating Systems.....	3
Combustion Air Requirements	10
Common Venting Requirements.....	11
Gas Service	12
Optional Controls And Wiring	13
Argo AMB Controls.....	14

Typical Layouts for Hot Water Heating Systems

Figure 1 - Two (2) Unit Configuration

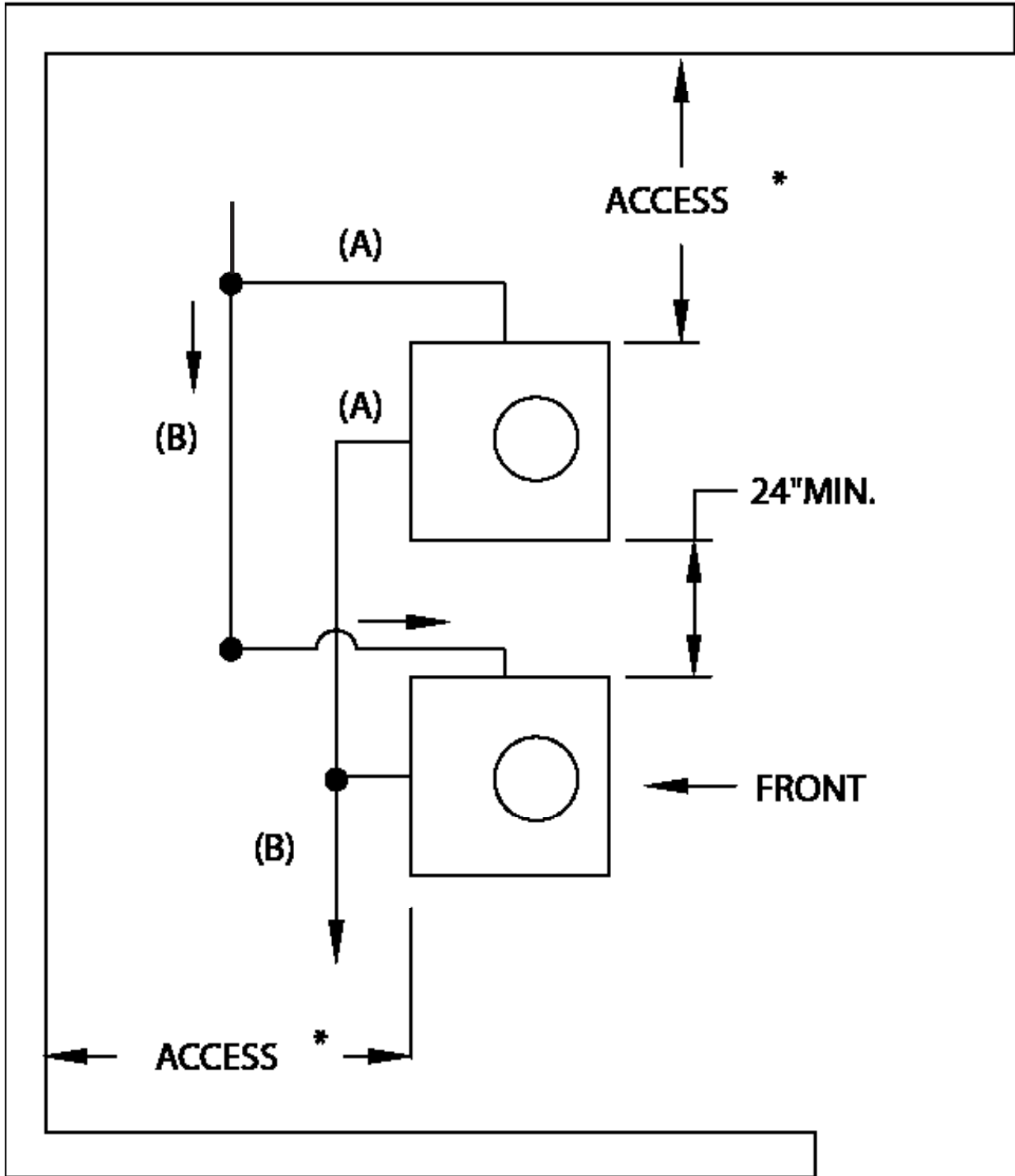

LEGEND - PIPE SIZING

(A) - 1 1/4 NPT SUPPLY AND RETURN

(B) - SYSTEM PIPING

Note:

- Access * is minimum 24" service clearance.
- Vent position, relief valve location, supply and return piping will vary depending on type of units.

Typical Layouts for Hot Water Heating Systems

Figure 2 - Three (3) Unit Configuration

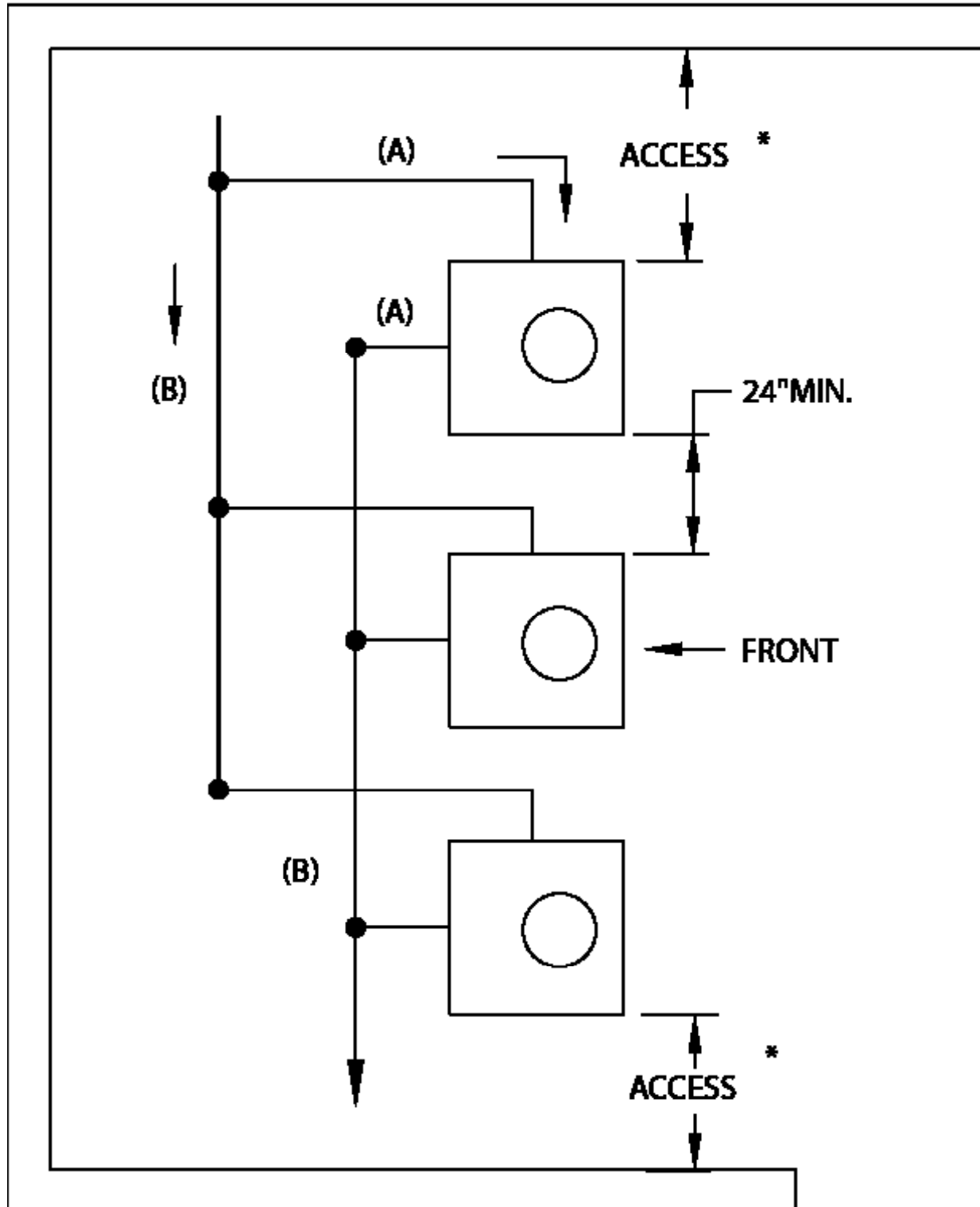

LEGEND - PIPE SIZING

(A) - 1¼ NPT SUPPLY AND RETURN

(B) - SYSTEM PIPING

Note:

- Access * is minimum 24" service clearance.
- Vent position, relief valve location, supply and return piping will vary depending on type of units.

Typical Layouts for Hot Water Heating Systems

Figure 3 - Four (4) Unit Configuration

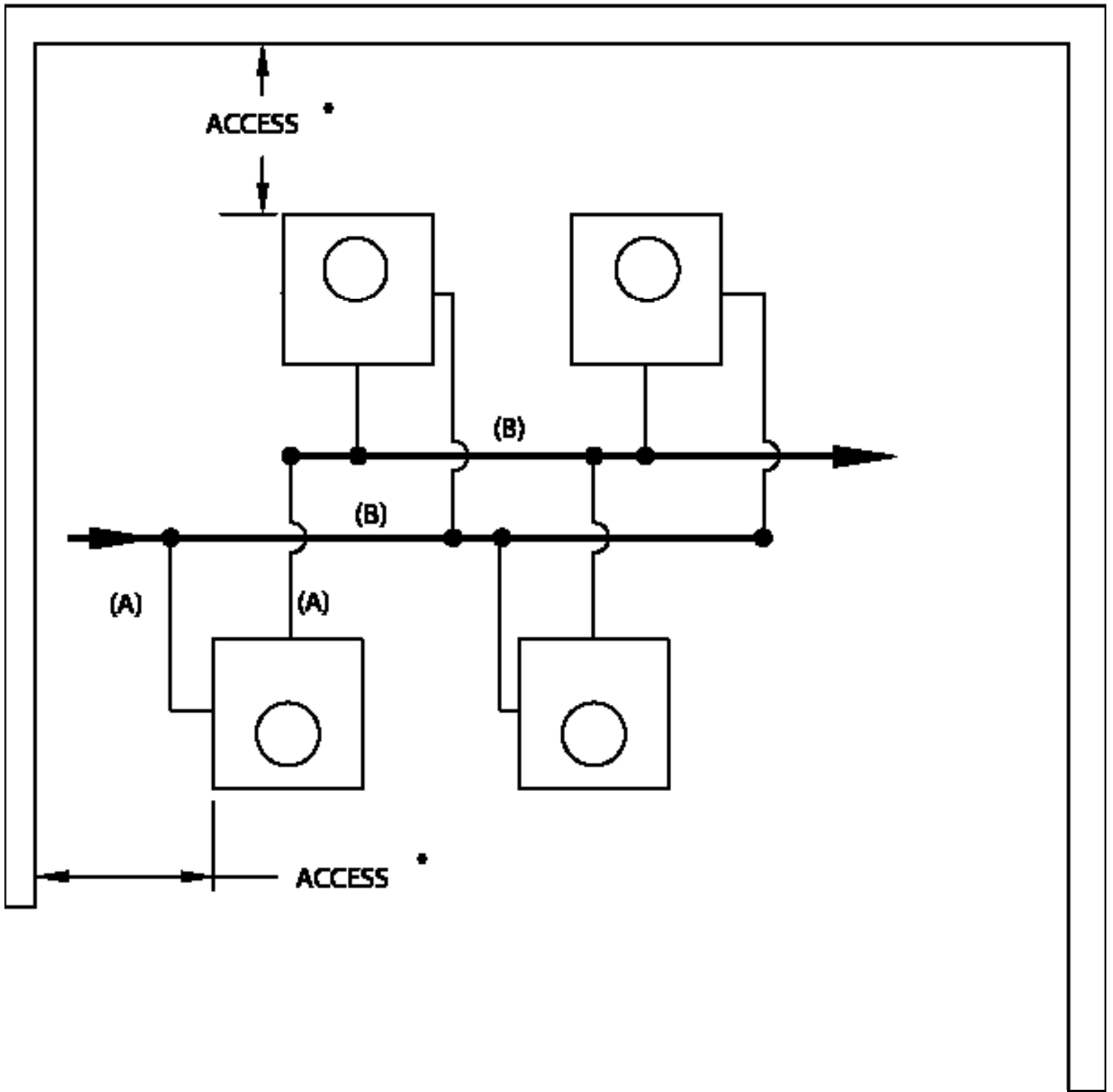

LEGEND - PIPE SIZING

(A) - 1 1/4 NPT SUPPLY AND RETURN

(B) - SYSTEM PIPING

Note:

- Access * is minimum 24" service clearance.
- Vent position, relief valve location, supply and return piping will vary depending on type of units.

Typical Layouts for Hot Water Heating Systems

Figure 4 - Four (4) Unit Configuration - Two Headers

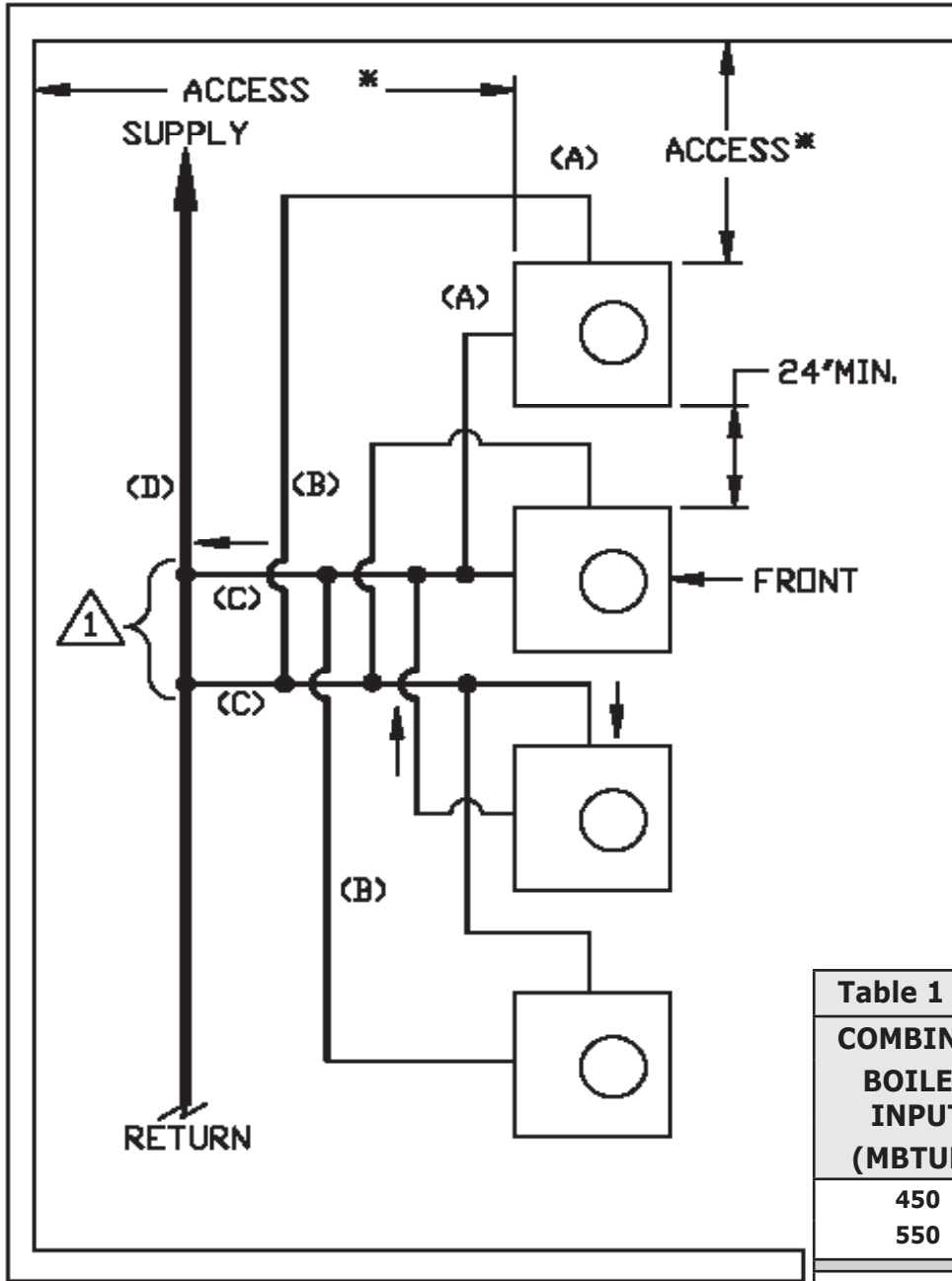

Table 1 - HYDRONIC PIPE SIZING GUIDE			
COMBINED BOILER INPUT (MBTUH)	(Fig. 4 & Fig. 6 ONLY)		
	MINIMUM PIPE SIZE (NPT)		
	(A)	(B)	HEADER (C)
450	1-1/4"	1-1/2"	3"
550	1-1/4"	1-1/2"	3"
600	1-1/4"	1-1/2"	3"
750	1-1/4"	1-1/2"	3"
900	1-1/4"	1-1/2"	3"
1,000	1-1/4"	2"	3"
1,200	1-1/4"	2"	3"
1,500	1-1/4"	2"	3"
1,800	1-1/4"	2"	3"
2,000	1-1/4"	2"	3"
2,400	1-1/4"	2"	3"
(D) SYSTEM PIPING - SIZE TO SUIT			

LEGEND

△ - 12" Maximum between closely spaced tees.

Note:

- Access * is minimum 24" service clearance.
- Vent position, relief valve location, supply and return piping will vary depending on type of units.

Typical Layouts for Hot Water Heating Systems

Figure 5 - Eight (8) Unit Configuration

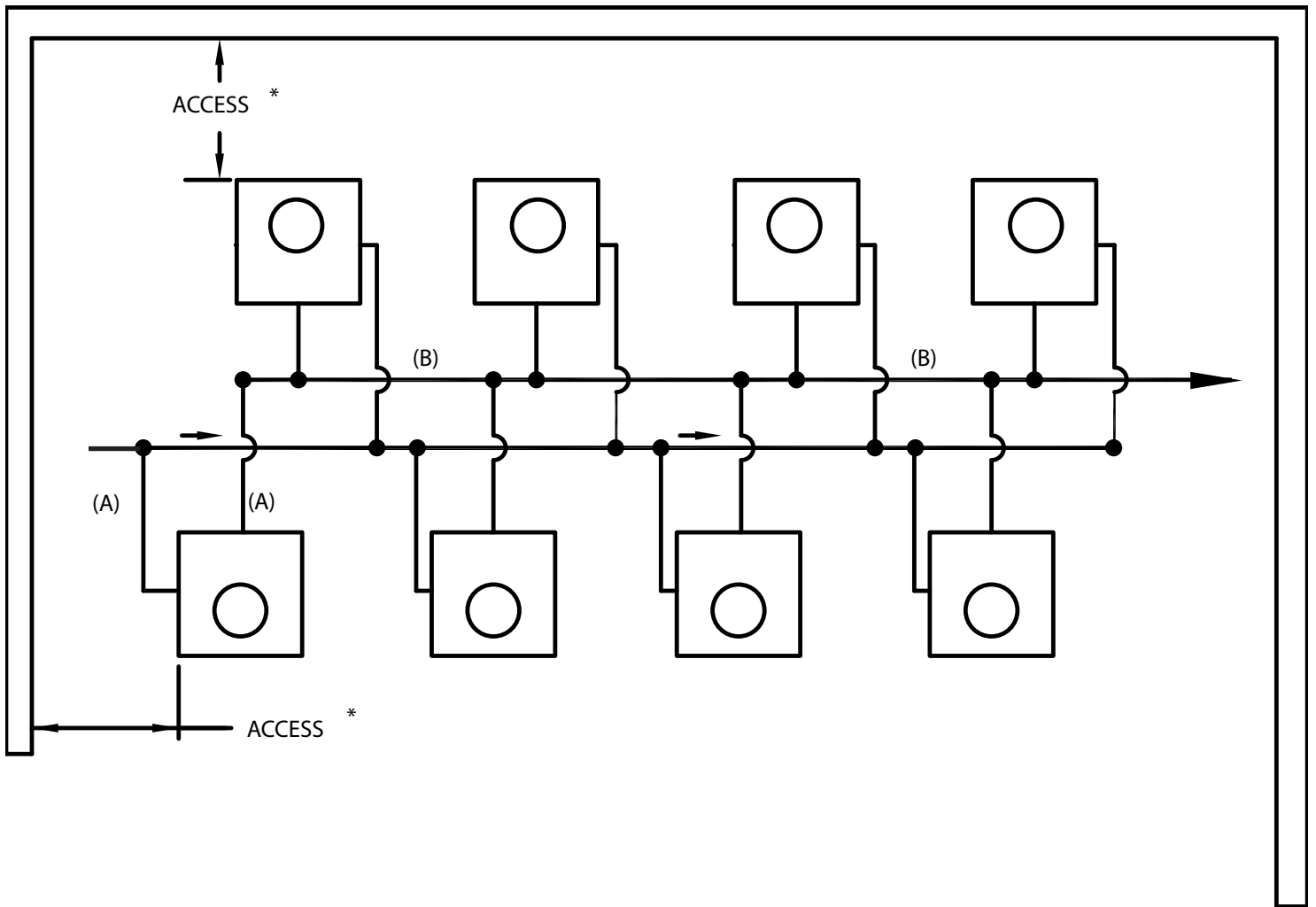

LEGEND - PIPE SIZING

(A) - 1¼ NPT SUPPLY AND RETURN

(B) - SYSTEM PIPING

Note:

- Access * is minimum 24" service clearance.
- Vent position, relief valve location, supply and return piping will vary depending on type of units.

Typical Layouts for Hot Water Heating Systems

Figure 6 - Eight (8) Unit Configuration - Two Headers

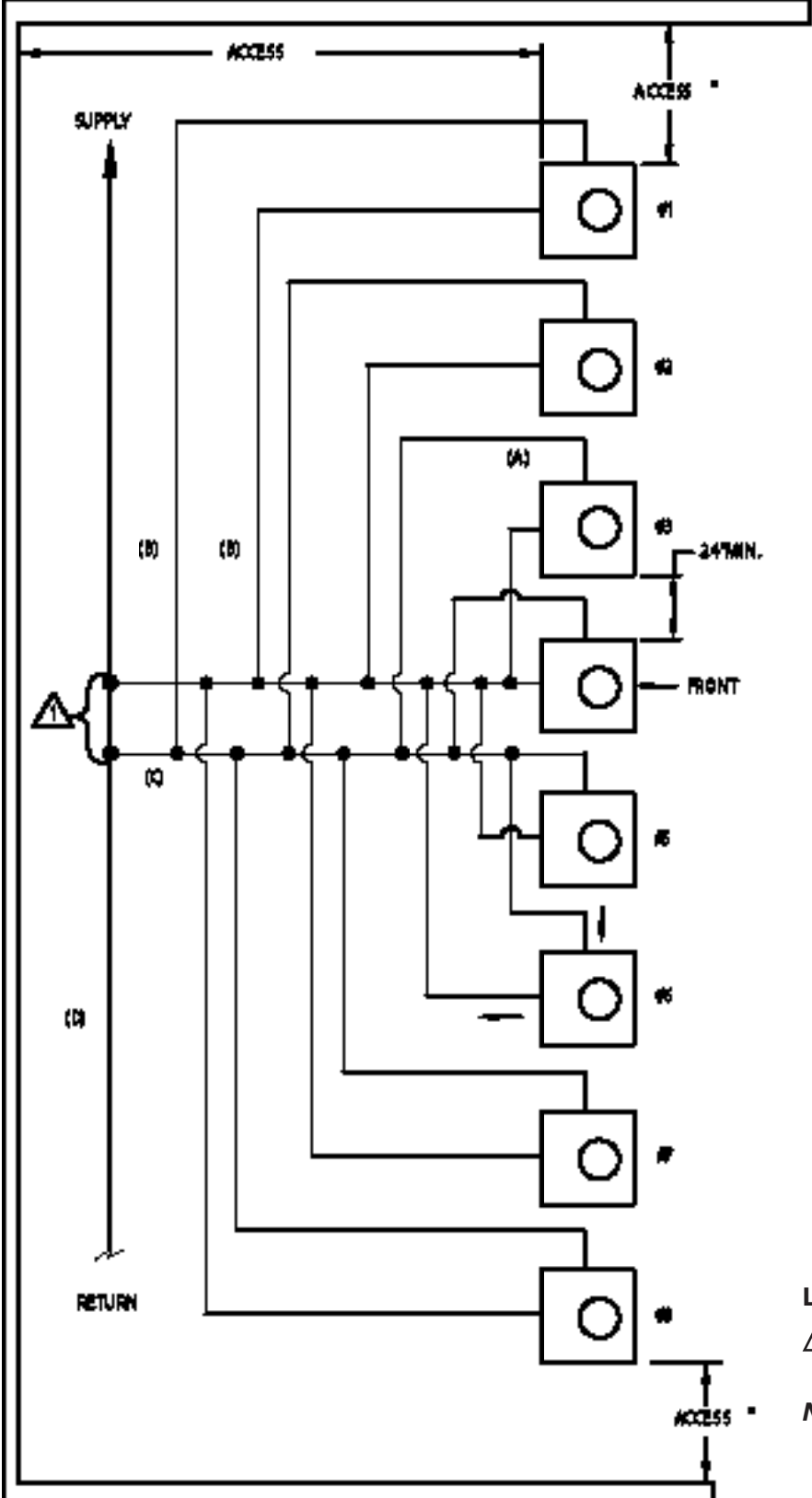

Table 2 - HYDRONIC PIPE SIZING GUIDE

COMBINED BOILER INPUT (MBTUH)	(4 & 6 UNITS ONLY)		
	MINIMUM PIPE SIZE (NPT)		
	(A)	(B)	HEADER (C)
450	1-1/4"	1-1/2"	3"
550	1-1/4"	1-1/2"	3"
600	1-1/4"	1-1/2"	3"
750	1-1/4"	1-1/2"	3"
900	1-1/4"	1-1/2"	3"
1,000	1-1/4"	2"	3"
1,200	1-1/4"	2"	3"
1,500	1-1/4"	2"	3"
1,800	1-1/4"	2"	3"
2,000	1-1/4"	2"	3"
2,400	1-1/4"	2"	3"
(D) SYSTEM PIPING - SIZE TO SUIT			

LEGEND

△ - 12" Maximum between closely spaced tees.

Note:

- Access * is minimum 24" service clearance.
- Vent position, relief valve location, supply and return piping will vary depending on type of units.

Typical Layouts for Hot Water Heating Systems

Figure 7 - Typical Layouts for Modular Gas Fired Systems

TYPICAL LAYOUTS FOR MODULAR GAS FIRED SYSTEMS

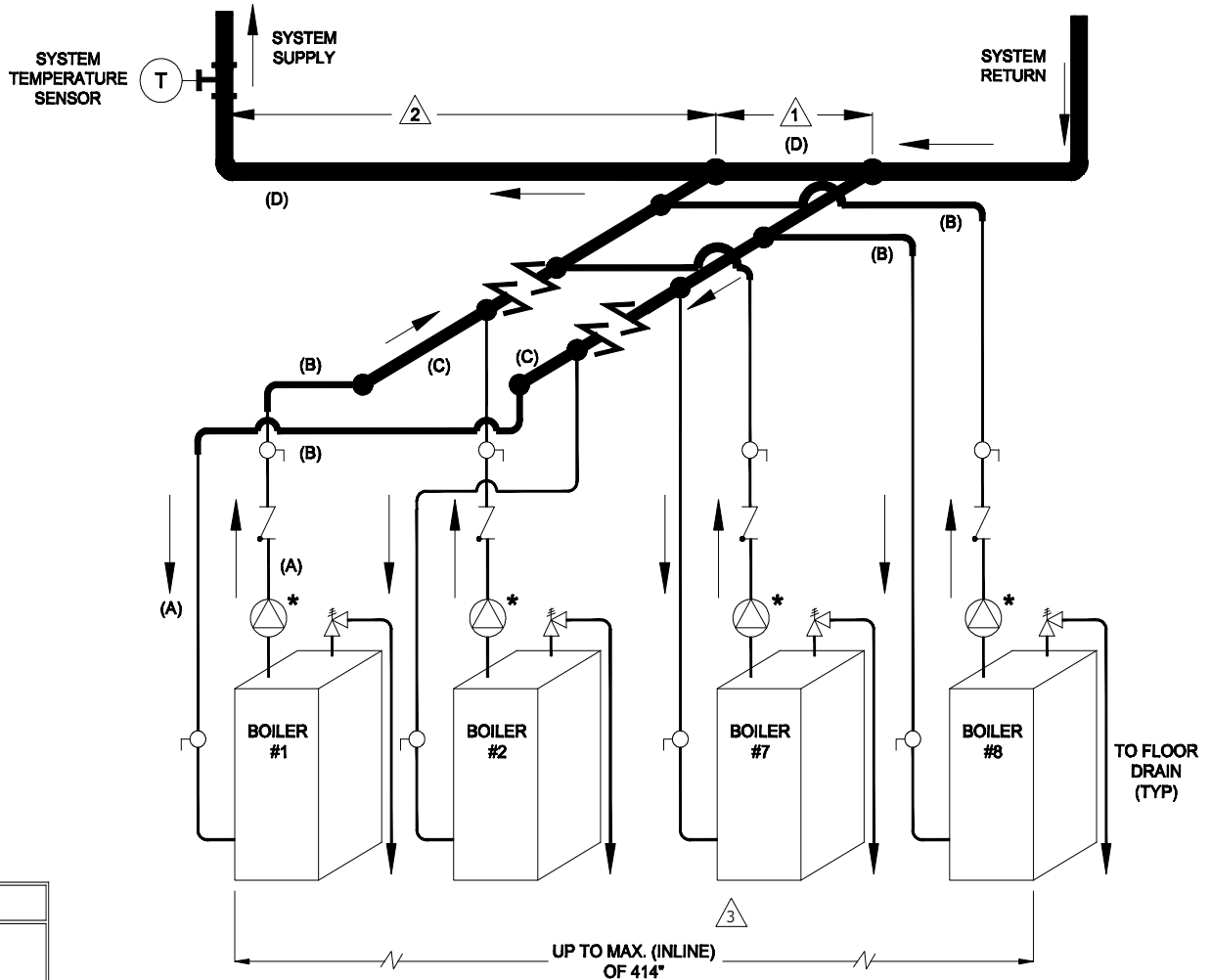

LEGEND	
	CHECK VALVE
	SHUT OFF VALVE
	CIRCULATOR
	PIPE CONNECTION
	TEMPERATURE SENSOR - SYSTEM
	PRESSURE RELIEF VALVE

UP TO 8 BOILERS

LEGEND

- 12" Maximum between closely spaced tees.
- Locate temperature sensor within 3 to 5 feet after supply header.
- Maximum overall length is based on using (8) boilers having largest footprint and 24" minimum service clearance between units.

Note:

- Modules may be placed back to back to save space.
- For sizing system or zone circulators, apply 10 GPM per 100,000 BRU (net) output. For sizing individual circulators use minimum Taco-007 or equivalent.

Combustion Air Requirements

Refer to the individual boiler Installation, Operation and Maintenance Manual.

⚠ WARNING

Asphyxiation hazard. Do not obstruct air openings to combustion area. Follow the chart below for adequate combustion air. Failure to comply could result in death or serious injury.

**Table 3 - COMBUSTION AIR REQUIREMENTS
(Minimum Opening In Square Inches)**

Total Boiler Input (MBH)	*UNCONFINED AREA		**CONFINED AREA OUTSIDE COMBUSTION AIR		When Using Mechanical Air Supply System
	Outside Combustion Air 1 Sq. In./4000 Btuh (See Figure 9)	Outside Combustion Air 1 Sq. In./1000 Btuh (See Figure 8)	Vert. Ducts 1 Sq. In./4000 Btuh	Horz. Ducts 1 Sq. In./2000 Btuh	Minimum CFM
500	125	500	125	250	175
600	150	600	150	300	210
750	188	750	188	375	263
900	225	900	225	450	315
1000	250	1000	250	500	350
1200	300	1200	300	600	420
1500	375	1500	375	750	525
1800	450	1800	450	900	630
2100	525	2100	525	1050	735
2400	600	2400	600	1200	840

* **Unconfined Area:** A space whose volume is not less than 50 cubic feet per 1000 Btu per hour of all appliances installed in that space (Cubic feet of space = height x width x length).

** **Confined Area:** A space whose volume is less than 50 cubic feet per 1000 Btu per hour of all appliances installed in that space (Cubic feet of space = height x width x length).

Figure 8 - Combustion Air Openings

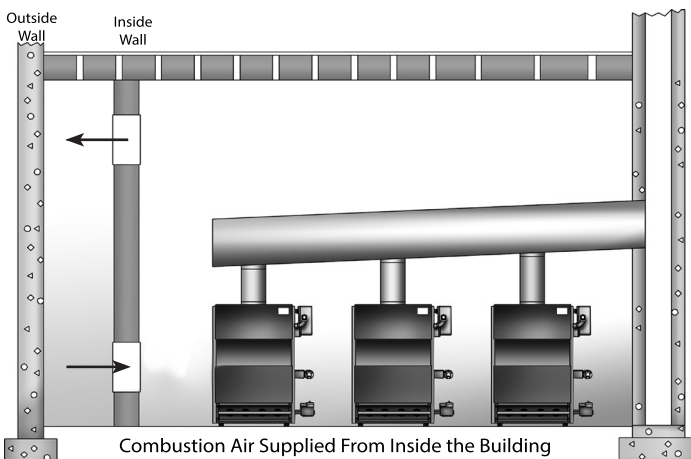
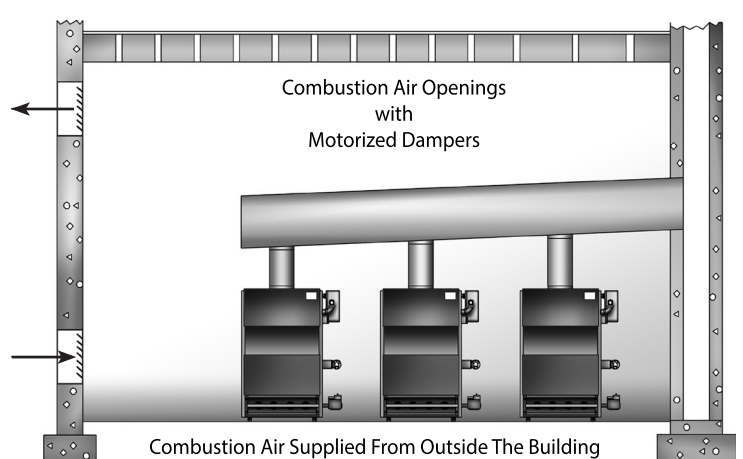

Figure 9 - Combustion Air with Motorized Dampers



Common Venting Requirements

Table 4 - Common Vent Sizing Table for Multiple Boilers

COMBINED INPUT (BTUH) x1000	COMMON VENT SIZING (INCHES)						
	Vertical Vent Height (Ft)						
	6'	8'	10'	20'	30'	50'	100'
450	12	10	10	9	8	8	7
550	12	12	12	10	9	9	8
600	14	12	12	12	10	9	9
750	14	14	14	12	12	10	9
900	16	14	14	12	12	12	10
1,000	16	16	16	14	12	12	12
1,200	18	18	16	14	14	12	12
1,500	20	18	18	16	14	14	12
1,800	22	20	20	18	16	14	14
2,000	24	22	20	18	18	16	14
2,400	24	24	22	20	18	16	14

Table 4 based on TYPE-B Double-Wall vent using **un-assisted** Common Vent system. Reference is NFPA-54 / ANSI Z223.1 National Fuel Gas Code.

Consult NFPA-54 / ANSI Z223.1 National Fuel Gas Code, for "Mechanical Vent" Sizing and additional vent information.

Maximum Horizontal Vent Length shall not exceed allowable [Common Header Vent Size x 18"]. See Table 5. If longer Horizontal Vent Lengths are required – percentage reduction in capacity must be made to Table values. Consult NFPA-54 / ANSI Z223.1 National Fuel Gas Code.

Table 5 - Maximum Horizontal Length of Common Vent

COMMON VENT DIAMETER (INCHES)	MAXIMUM HORIZONTAL LENGTH FEET [INCHES]
7	10.5 [126"]
8	12.0 [144"]
9	13.5 [162"]
10	15.0 [180"]
12	18.0 [216"]
14	21.0 [252"]
16	24.0 [288"]
18	27.0 [324"]
20	30.0 [360"]
22	33.0 [396"]
24	36.0 [432"]

Gas Service

See individual unit's Installation, Operation & Maintenance Manual for piping requirements.

Table 6 - Pipe Sizes In Inches For Natural Gas Main								
Total Input	Run Length in Feet							
	20'	30'	40'	50'	60'	80'	100'	125'
500	1.25"	1.25"	1.50"	1.50"	2.00"	2.00"	2.00"	2.00"
600	1.25"	1.25"	1.50"	1.50"	2.00"	2.00"	2.00"	2.00"
750	1.25"	1.50"	1.50"	2.00"	2.00"	2.00"	2.00"	2.00"
900	1.50"	2.00"	2.00"	2.00"	2.00"	2.00"	2.50"	2.50"
1000	1.50"	2.00"	2.00"	2.00"	2.00"	2.50"	2.50"	2.50"
1200	2.00"	2.00"	2.00"	2.00"	2.50"	2.50"	2.50"	2.50"
1500	2.00"	2.00"	2.50"	2.50"	2.50"	2.50"	3.00"	3.00"
1800	2.00"	2.50"	2.50"	2.50"	2.50"	3.00"	3.00"	3.00"
2100	2.50"	2.50"	2.50"	3.00"	3.00"	3.00"	3.00"	4.00"
2400	2.50"	2.50"	3.00"	3.00"	3.00"	3.00"	3.00"	4.00"

Table based on pressure drop of 0.3" water column at less than 2 psi inlet gas pressure.

Based on Natural gas and schedule 40 piping.

For other conditions and LP gas piping consult NFPA 54.

Figure 10 - Gas Piping - Modular Boilers

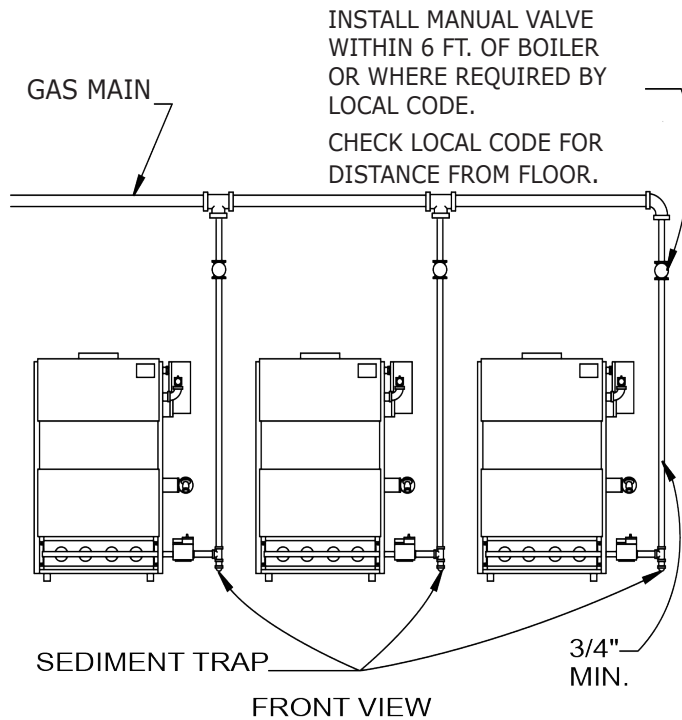

Optional Controls and Wiring

Following descriptions outline control options for modular systems.

Argo AMB4A and AMB8A Multiple Boiler Sequencers

- AMB4A and AMB8A multiple boiler sequencers are capable of sequentially step firing up to 4 (AMB4A) or 8 (AMB8A) heating boilers. See Figures 11 and 12.
- The number of boilers fired is adjusted by the AMB control depending on system heating load and outdoor temperature.
- AMB control will adjust control point of system water temperature based on the temperature that the outdoor air sensor is reading.
- Number of hours on each boiler in the system is recorded and each day the AMB control will choose the boiler with the fewest hours to be the lead boiler for the day to attempt to run each boiler equally and extend boiler life.
- Setpoint, reset ratio, rotation and many other features are easily programmed in the field through the four button user interface.

Operation

- When used in a continuous application the AMB will regulate the water temperature in the system through the use of the water sensor and it will always keep the water warm.
- AMB will monitor the water temperature until the temperature drops the number of degrees below the control point that the temperature differential feature is set to.
- The control will then bring on the lead boiler. The AMB will monitor the boiler temperature and if it has not reached the control point it will bring on the next boiler.
- Boilers will be phased on or off based on how close the water temperature is to the control point.
- If at any point the water temperature is 10°F above the control point, all boilers will turn off.

Argo AMB Controls

Figure 12 - Wiring ARGO AMB - 8 Control to Multiple Boilers

Model Number	Domestic / International	Transformer Voltage
ARGO AMB-8	Domestic	120V/60Hz/40Va

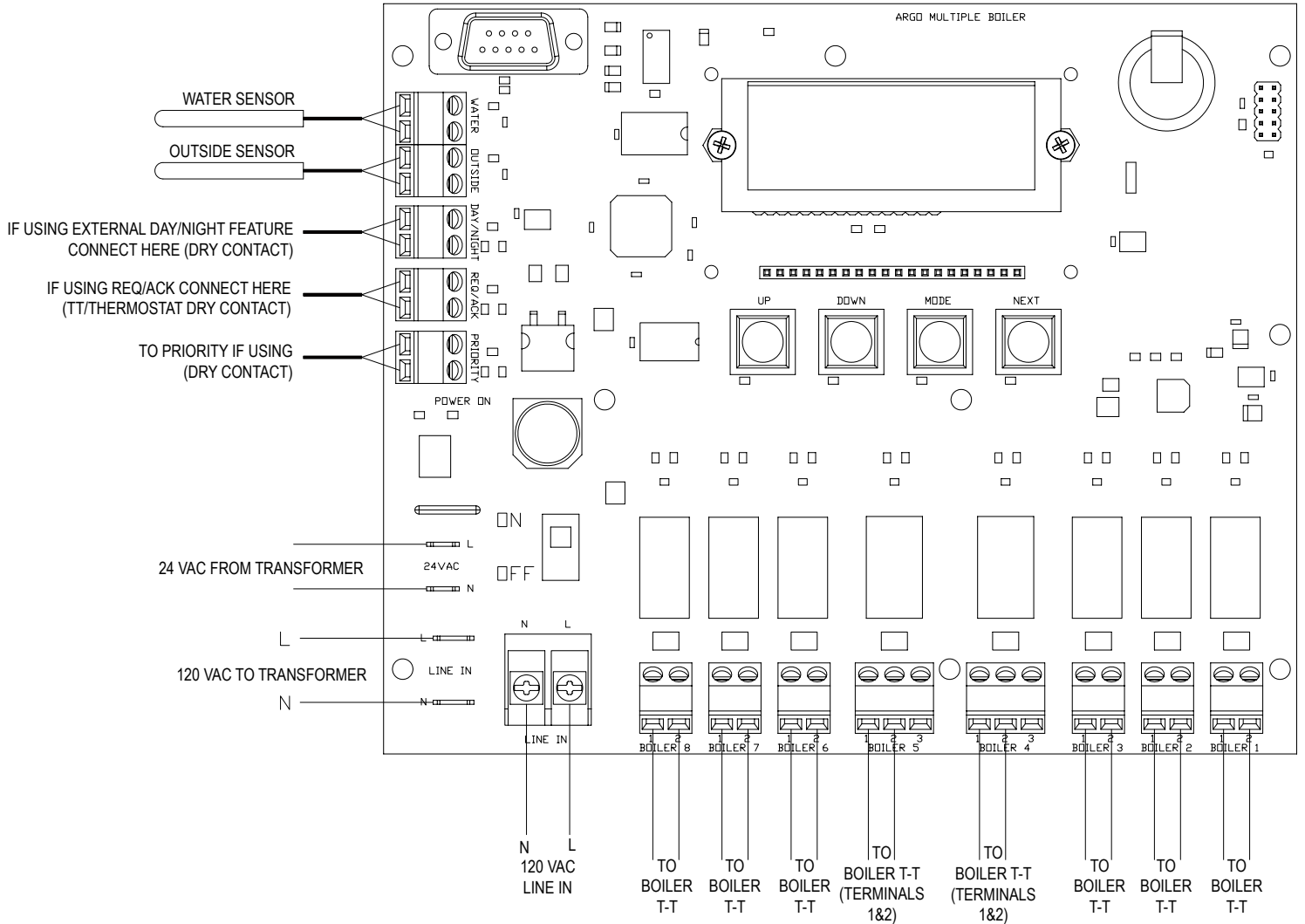

Consult ARGO AMB installation manual for additional information.

