

***SUPPLEMENTAL***  
**INSTALLATION AND OPERATING  
INSTRUCTIONS**  
**CSD-1 COMMERCIAL BOILER CONTROLS**

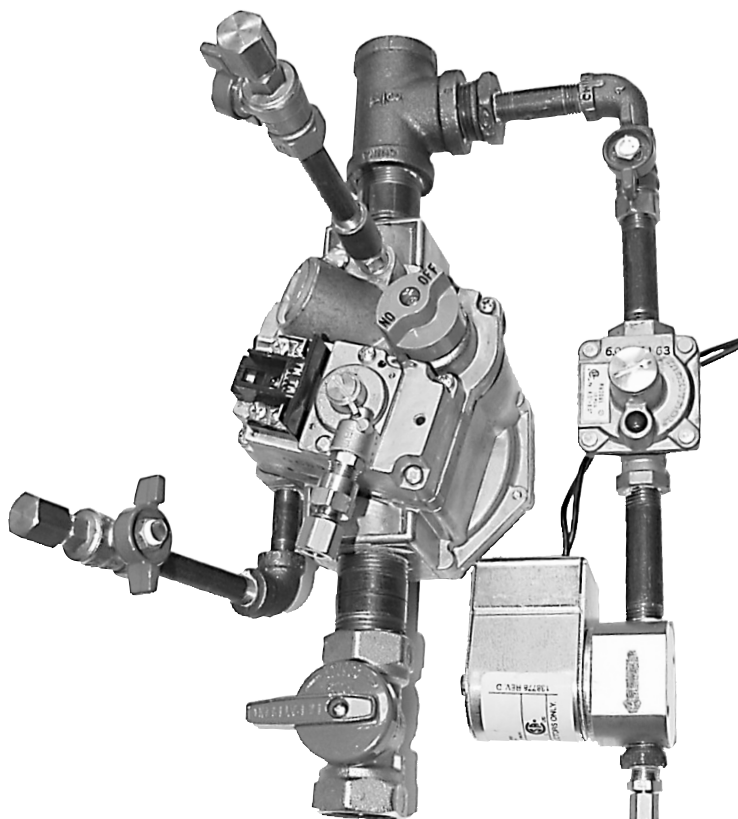

### **WARNING**

Fire, explosion, asphyxiation and electrical shock hazard. Improper installation could result in death or serious injury. Read this manual and understand all requirements before beginning installation.

Your commercial boiler is furnished with combustion side water or steam controls to meet our interpretation of the American Society of Mechanical Engineers (ASME) Safety Code for Controls and Safety Devices for Automatically Fired Boilers, No. CSD-1.

Installation shall conform to the requirements of the authority having jurisdiction, or, in the absence of such requirements, to the National Fuel Gas Code, ANSI-Z223.1/NFPA-54 (latest revision). Where required by the authority having jurisdiction, the installation shall conform to the American Society of Mechanical Engineers (ASME) Safety Code for Controls and Safety Devices for Automatically Fire Boilers, No. CSD-1.

CSD-1 controls and this installation may be subject to approval by local inspectors. Additional parts or equipment may be required. Consult local authorities having jurisdiction before the installation of the boiler.

CSD-1 controls furnished with commercial boilers are applicable to boilers with inputs above 400,000 Btu/hr. (Models 500-1500)

Additional parts required by CSD-1 standards may be necessary to make this boiler compliant. This supplemental instruction manual should be used in conjunction with the Installation, Operation and Maintenance manual for your specific boiler.

### **CSD-1 Component Installation**

Based on parts listed in Installation, Operation and Maintenance manual for your particular boiler, the following changes should be made:

**Complete Boiler Material List** - See Table #1: CSD-1 Complete Boiler Material List.

### **Combustion Side Control :**

- Models 300 and 400, no changes are required to existing gas trains.
- Models 500 through 1500 requirements include:
  - A. Intermittent pilot control module is required to have maximum 15 second pilot flame establishing period and ability to perform safety shutdown and lockout in event of loss of flame signal at pilot.
  - B. The intermittent pilot module and manual reset switch are used to replace the existing pilot module.

- C. Also, an independent pilot gas line which includes manual shutoff valve, pressure regulator and safety shutoff valve, two leak test valves on main gas valve, and manual shutoff valve located downstream of the main gas valve are added. See

See Table #2: CSD-1 Component Carton Material List for component carton material list which replaces the corresponding list in the installation manuals.

- See Table #3: CSD-1 Electronic Ignition Base Material List.
- Installed locations of additional components see Figures 1a and 1b.

For CSD-1 combustion side control, light off sequence is as follows:

1. Turn on power. Set thermostat to call for heat.
2. Ignition starts to spark and lights pilot flame.
3. Ignition continues sparking about 12 seconds after pilot lights.
4. Main burners ignite.

### **NOTICE**

A longer pilot flame recognition time is a design feature of this module and is correct.

### **Gas Pressure Requirements**

- Maximum allowable inlet gas pressure (natural gas only) to controls in CSD-1 gas train is 14" w.c. (½ psig).
- Verify inlet gas pressure is at least 5" w.c. but no greater than 14" w.c.
- If gas pressure entering the building is greater than 14" w.c., installing contractor must provide overpressure protection on downstream piping to prevent buildup of downstream pressures in excess of 14" w.c. in event the fuel system pressure regulator fails.
- Alternatively, gas pressure entering the building may be reduced with additional gas pressure regulator outdoors. If inlet gas pressure to this additional regulator is less than 14" w.c., then overpressure protection may not be required.
- Consult local authority(s) having jurisdiction before installing gas supply piping to the boiler.

## MATERIAL LISTS

**Table #1: CSD-1 Complete Boiler Material List**

Model	Sections			CSD-1 Component Carton <sup>a &amp; b</sup>			Steam Trim Carton <sup>d</sup>	CSD-1 AC Carton	Jacket End Panel Carton	Base End Panel Carton
	L	Inner	R	300 CSD-1	400 CSD-1	500 CSD-1				
300	1	2	1				SA-1	300	1	1
400	1	3	1				SA-1	400	1	1
500	1	4	1			1	SA-1	500	1	1
600	1	5	1	2			SA-2	600	1	1
700	1	6	1	1	1		SA-2	700	1	1
800	1	7	1		2		SA-3	800	1	1
900	1	8	1		1	1	SA-3	900	1	1
1000	1	9	1			2	SA-3	1000	1	1
1100	1	10	1	1	2		SA-3	1100	1	1
1200	1	11	1		3		SA-3	1200	1	1
1300	1	12	1	1		2	SA-3	1300	1	1
1400	1	13	1		1	2	SA-3	1400	1	1
1500	1	14	1		3	3	SA-4	1500	1	1

- a. Boilers having total inputs of 400 MBH or less as complying with ANSI Z21.13 (Models 300 and 400), the standard combustion side controls meet CSD-1 and no changes to the standard component carton are required.
- b. There are additional parts on base assemblies for boilers having total inputs from 500 to 1,500 MBH (Models 500 to 1500) to meet CSD-1. See **"Table 2: CSD-1 Component Carton Material List"** for details.
- c. For steam boilers, there is an additional CSD-1 steam trim carton for gravity or condensate pump return (Part# 41257103) or an additional CSD-1 steam trim carton for boiler feed pump return (Part# 41257104). See appropriate CSD-1 Steam Trim Carton Material List (**Tables 5a and 5b**) for details.

**Table #2: CSD-1 Component Carton Material List**

Description	Stock No.	Unit	550001664	550001665	550001666
			300 CSD-1	400 CSD-1	500 CSD-1
300 Base Assembly CSD-1	550001670	Ea.	1		
400 Base Assembly CSD-1	550001671	Ea.		1	
500 Base Assembly CSD-1	550001672	Ea.			1
300 Intermediate Jacket Carton	550001673	Ea.	1		
400 Intermediate Jacket Carton	550001674	Ea.		1	
500 Intermediate Jacket Carton	550001675	Ea.			1
300 Draft Hood	42557113	Ea.	1		
400 Draft Hood	42557114	Ea.		1	
500 Draft Hood	42557115	Ea.			1
Control Panel Assembly	550001801	Ea.			
Control Panel Assembly CSD-1 300/400	550001869	Ea.	1	1	
Control Panel Assembly CSD-1 500	550001870	Ea.			1
Top Front Panel 300	109009216	Ea.	1		
Top Front Panel 400	109009217	Ea.		1	
Top Front Panel 500	109009210	Ea.			1

Boilers having total inputs of 400 MBH as complying with ANSI Z21.13 (Models 300 and 400), the standard combustion side controls meet CSD-1 and no changes to the standard component carton are required.

## MATERIAL LISTS

**Figure 1a - CSD-1 500 Gas Train**

**Figure 1b - CSD-1 500 Gas Train**

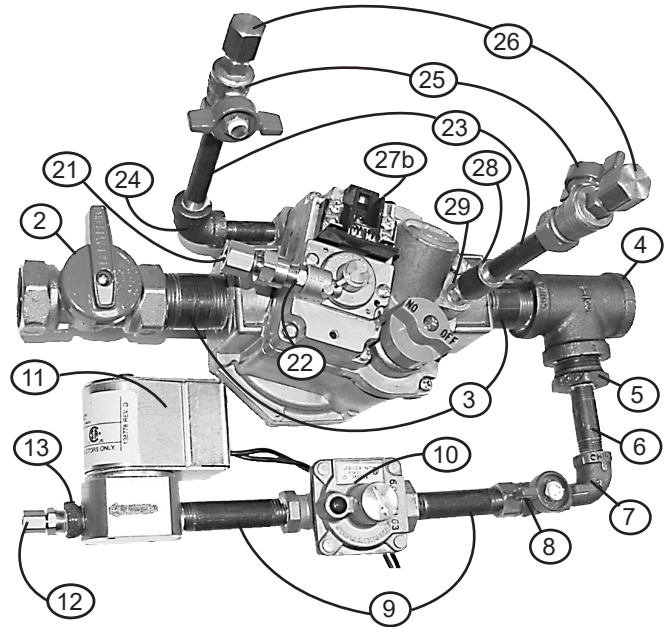
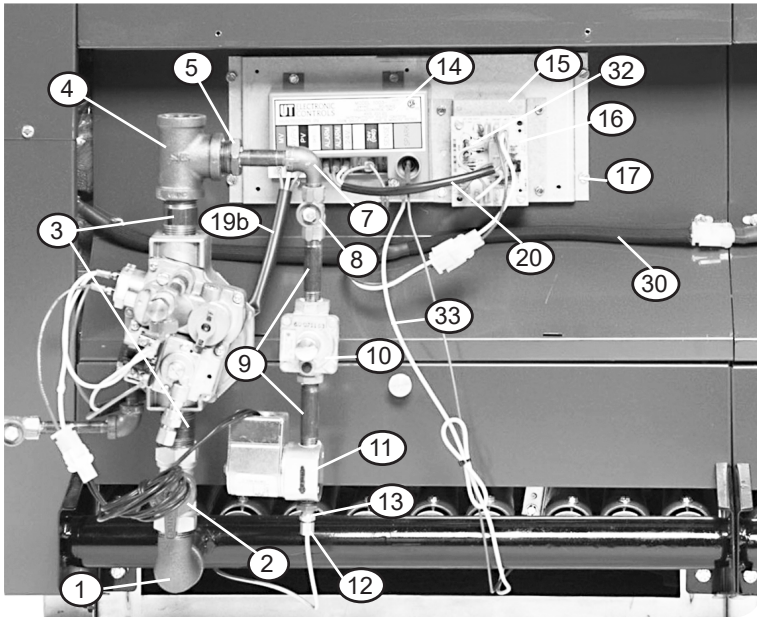

**Table #3: CSD-1 Electronic Ignition Base Material List**

Item	Description	Part No.	Qty.
1	3/4" 90 Street Elbow Back	14693040	1
2	3/4" Manual Shutoff Valve	14657001	1
3	3/4" x 2" Nipple Black	14607201	2
4	3/4" Tee Black	14693076	1
5	3/4" x 1/4" Bushing	1060002	1
6	1/4" x 2" Nipple Black	1310018	1
7	1/4" Street Elbow Black	14657007	1
8	1/4" Manual Shutoff Valve	14657002	1
9	1/4" x 2 1/2" Nipple Black	14607000	2
10	1/4" Gas Pres. Regulator, 6" w.c.	14657004	1
11	1/4" Magnetic Valve w/Connector Assembly	43357103	1
12	1/8" NPT x 1/8" Tube M. Connector	14657019	1
13	1/4" x 1/8" Bushing	14657008	1
14	Control STP W/Alarm	1140007	1
15	Control Mounting Panel, CSD-1 24 GA Galv	109006833	1
16	Control CSD Lockout Daughter Board	1140008	1
17	Control Mounting Panel	109006832	1
18*	Screws, #8 x 3/8 Self Tap	201000001	8

**Table #3: Continued**

Item	Description	Part No.	Qty.
19a*	Harness CSD-1 Control (300, 400)	1263016	1
19b	Harness CSD-1 Control (500)	1263019	1
20	Harness CSD-1 Control	240006623	1
21	Compression Fitting, 1/8"NPT x 1/4" Tube	14657025	1
22	Brass Coupling, Male 1/8" x 5/16"-24	14657024	1
23	1/8" x 2 1/2" Nipple Black	14607804	2
24	1/8" 90 Elbow (500 Only)	14657010	1
25	1/8" Manual Shutoff Valve	14657003	2
26	1/8" Pipe Cap	14657012	2
27a*	Gas Valve, Electronic Ignition, Nat. (300, 400)	14662315	1
27b	Gas Valve, Electronic Ignition, Nat. (500)	14663001	1
28	1/8" Coupling Steel	14657013	1
29	CSD-1 Pilot Outlet Adapter	43357104	1
30	Wire Harness, Base to Base	240006732	1
31*	1/8" x 1 1/2", Nipple, Black (300, 400 Only)	14657009	1
32	Wire Jumper, CSD-1 Board (Orange)	1263017	1
33	Ground Wire, Spark (White)	371-1-21.01	1

\*Not Shown

## STEAM SIDE CONTROLS

**Steam Side Control** - Two low water cutoff devices and two pressuretrols, one with auto reset and the second with manual reset, are required. **In order to make the two low water cutoff devices work in the appropriate sequence, manufacture recommends locating both devices at same end of boiler.**

There are three different control systems for three different types of condensate returns.

Identify the three different types of condensate returns:

- Gravity return - condensate is returned by gravity.
- Condensate pump return - condensate is returned by pump(s), controlled by the water level in the condensate receiver tank.
- Boiler Feed Pump Return - condensate is returned by pump(s), controlled by the water level in the boiler.

### Gravity Return And Condensate Pump Return

With gravity and condensate pump return, additional control components are the same. See Table #5a and Figure #2 for tappings.

- Tappings B & B location shown in Figure #2. Installation shown in Figure #3, Primary LWCO and Pressuretrol with gauge glass set.
- Tappings D or F (Figure #2)- Manual reset pressuretrol and 1/4" 90° brass syphon.
- Tappings E & F - Secondary LWCO (w/manual reset). Use in conjunction with primary LWCO equipped on boiler.

When using two LWCOs, place manual reset lower than automatic LWCO. Water must be visible in gauge glass when manual reset trips.

- Figure 3 shows how to raise automatic (Series 67) LWCO 1-inch.
- Remove 1" from long side of 1/4" diameter 90° brass siphon tube.
- Remove nipple in series 67 and replace with 1 1/2" long nipple and street elbow.
- Water level control device located on condensate receiver tank and controls condensate return pump is not supplied.

**Figure 2 - Steam Boiler Feed Pump Return**

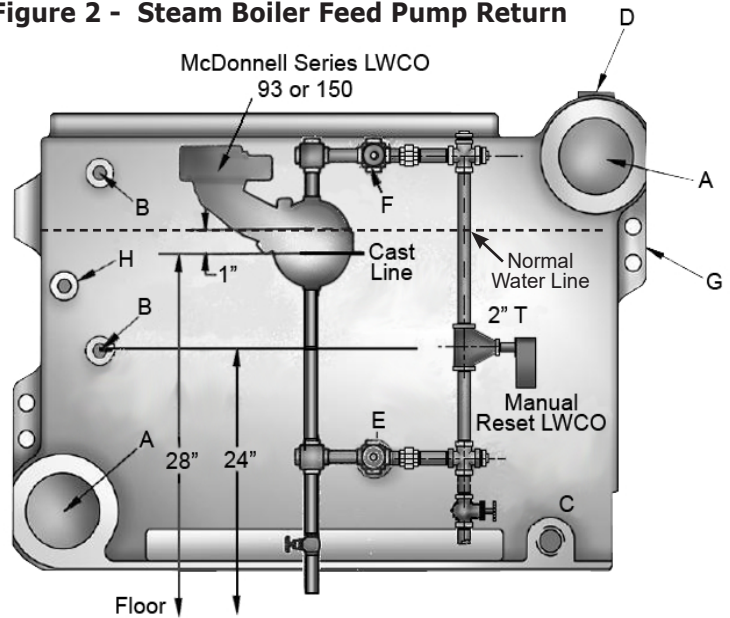

**Figure 3 - Steam Gravity and Condensate Pump Return**

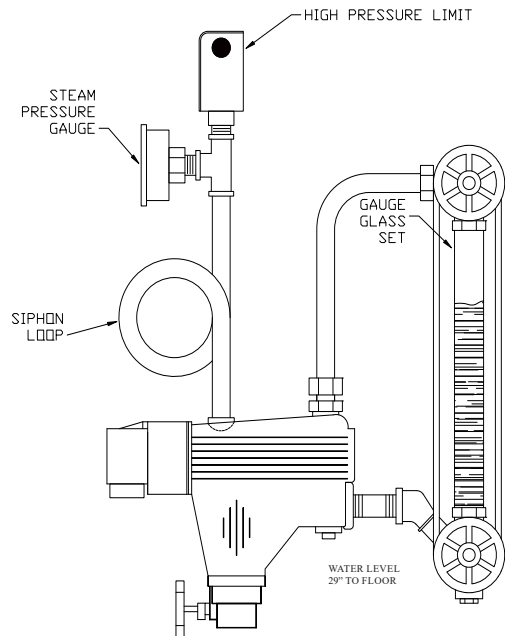

**Table #5a: CSD-1 Steam Trim Carton Material List for Gravity Return or Condensate Pump Return (Part No. 41257103)**

Item	Description	Part No.	Qty.
1	LWCO w/Manual Reset (secondary)	240007388	1
2	Bushing, Steel or Cast 1" x 1 1/4"	14657016	1
3	Pressure Switch Control, Manual Reset	14662311	1
4	90° Brass Syphon, 1/4"	14643004	1
5	ELB,ST,1/2",45 DEG.BRASS	240007541	1
6	NIPPLE 1/2" X 1/2"LG BRASS	240007542	1

## BOILER FEED PUMP RETURN

Boiler feed pump return additional parts See Table #5b.

See Figure #2 for installed locations of additional parts.

- **Tappings B & B** - Water gauge glass set and pressuretrol (requires fittings 4-7 in Table #5b).
- **Tapping D** - Steam gauge and pressuretrol (requires fitting 8 in Table #5b).
- **Tappings E & F** - LWCO (auto and manual) and pump control. Installer supply and size the steam (top) and water (bottom) equalizing pipe lengths so the horizontal cast line on the control body is 28" above floor. Secondary control is 24" above the floor. See Figure #2.

**Table #5b: CSD-1 Steam Trim Carton Material List For Boiler Feed Pump Return (Part No. 41257104)**

Item	Description	Part No.	Qty.
1	Pressure Switch Control, Manual Reset	14662311	1
2	LWCO and Pump Control (primary)	14626306	1
3	LWCO, MAN RESET, CSD-1 APRVD, SHT PROBE	240007388	1
4	90° Brass Syphon, 1/4"	14643004	1
5	Brass Nipple, 1/2" x 3 1/2"	14607024	2
6	Brass Tee, 1/2" x 1/2" x 1/4"	14693051	2
7	Brass Coupling, 1/2"	14693052	2
8	Bushing, 1/2" x 1/4"	1060001	1

## SEQUENCE OF OPERATION

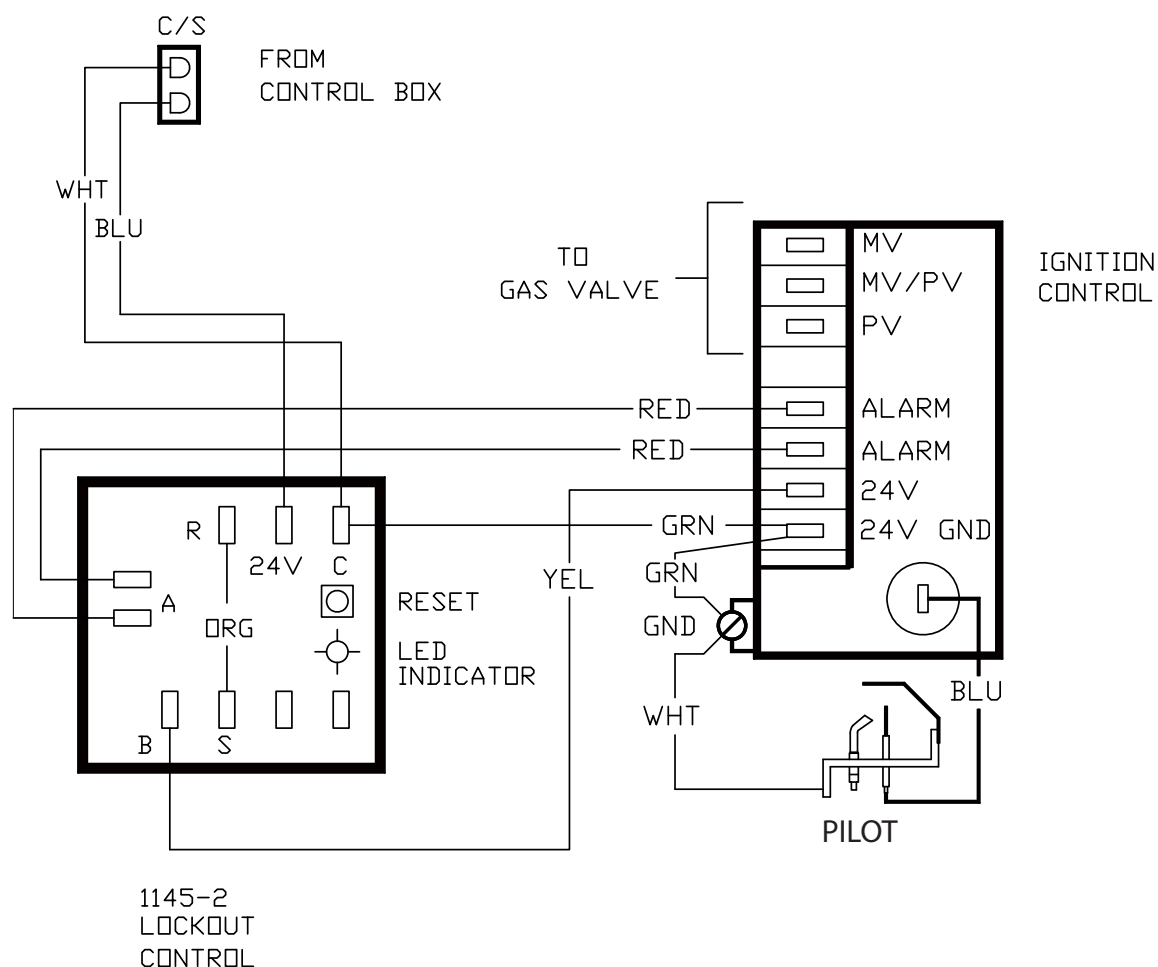

### Call For Heat

Control recognizes call for heat when power is applied to 24V terminal on control module. Since control receives signal from the thermostat, when call for heat is terminated, heating cycle immediately terminates and all control outputs will shut off.

### Ignition Trial Period

Control energizes pilot gas valve and spark outputs for ignition trial time of 12 seconds. If flame is sensed during 12 seconds of ignition trial, spark output is de-energized, main gas valve is energized, and control enters steady heat mode. If flame is not established within ignition trial period, control de-energizes the spark and gas valve and operates as described below in Ignition Failure/Re-try Sequence.

### Ignition Failure/Re-Try Sequence

After an unsuccessful ignition trial, control checks to see if maximum number of ignition trials (2 trials) has been completed. If maximum number of ignition trials has been completed, control will lockout. See Lockout (next page) for details.

If maximum number of ignition trials has not been completed, control delays for 5 minute inter-purge period. After the inter-purge, control attempts another ignition trial. Refer back to Ignition Trial Period for details.

### Steady-State Heating

Control keeps pilot gas valve and main gas valve energized while continuously monitoring call for heat and flame status. Control will remain in this steady-state heating mode until power is removed by (a) thermostat satisfied, (b) pressure switch opening, or (c) flame being lost.

If call for heat is satisfied, power is removed from control, de-energizing pilot gas valve and main gas valve.

If flame is lost, control will shut off main gas valve within one second, leave pilot gas on, and immediately start ignition trial. Control checks to see if maximum number of flame losses (2 per call for heat) has been reached. If maximum number of flame losses has been reached, control locks out. See Lockout section for details.

### **Gas Valve Sensing**

If either or both the pilot and main gas valves are sensed to be on when commanded to be off, or if no voltage appears at gas valve output which was commanded on, control will shut off all outputs and enter either "soft" or "hard" lockout state. Main valve is interlocked with the pilot valve and voltage can only be detected on main valve when pilot valve is energized. Control locks out the first time as "soft" lockout, then retries after 5 minutes and enters "hard" lockout state. Lockout should be manually reset as described in "Lockout."

### **Flame Present With Gas Off**

If flame is sensed for longer than 2 seconds during a period when gas valve should be closed, control will enter lockout.

### **Power Interruptions**

Power interruptions less than 0.15 seconds will not cause control to interrupt heat sequence while power interruptions over 0.25 seconds will cause the control to reset lockout and ignition trial counters. Power interruptions of any duration will not cause a lockout or any other operation requiring manual intervention.

### **Lockout**

Controller automatically resets from first lockout in 5 minutes. If second lockout occurs before call for heat is satisfied, it will require manually resetting by depressing red button on CSD-1 daughter board. This can be reached with a pencil through the vent holes. A red LED will also indicate lockout and can be seen through the vent holes.



# ELECTRICAL WIRE DIAGRAMS - GAS VALVE CONTROL WIRING

The suggested schematic wiring diagrams are included. Please use the appropriate one for the installation.

## CSD-1 HONEYWELL VR8304M,H MAIN GAS VALVE CONTROL WIRING

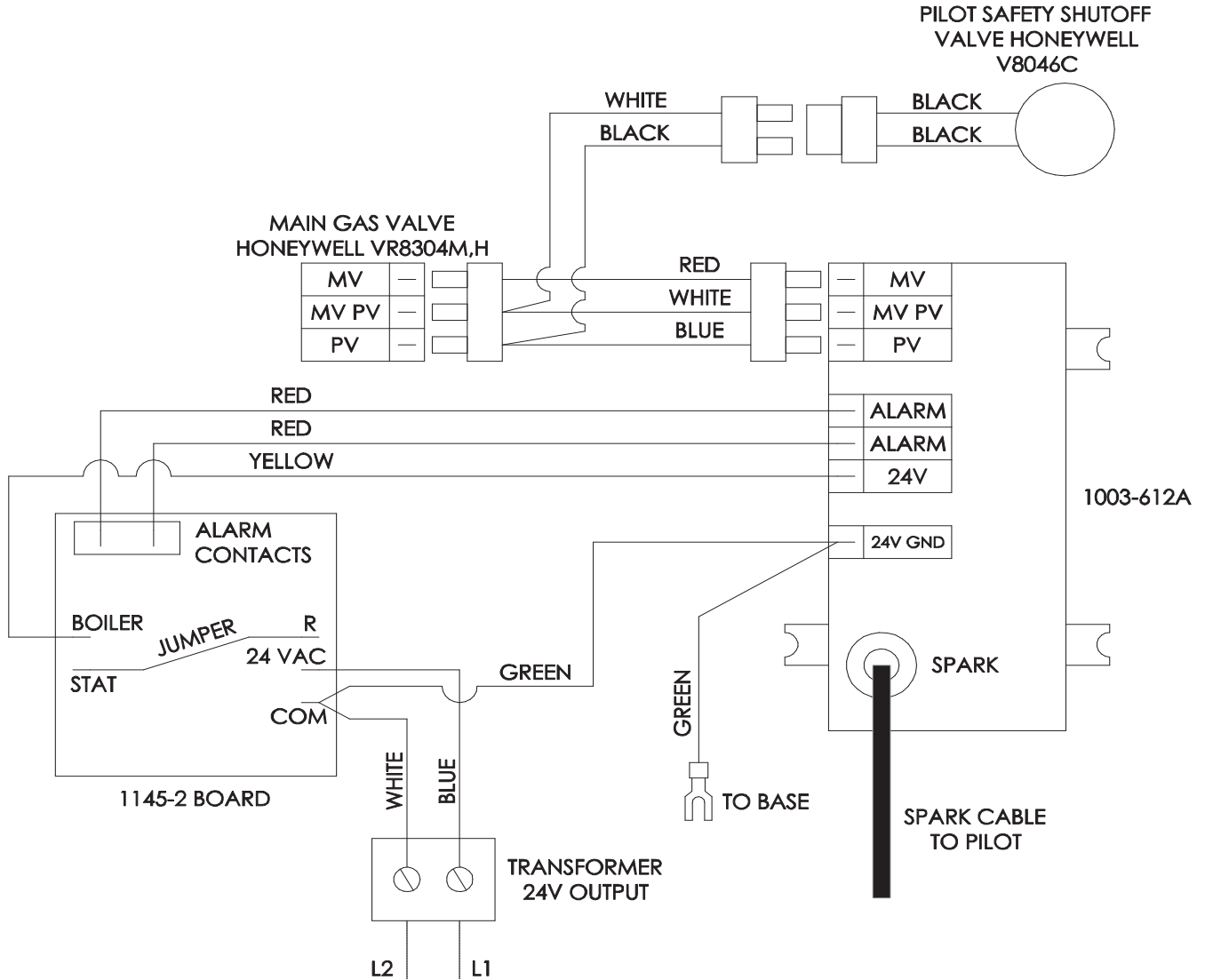

# ELECTRICAL WIRE DIAGRAMS - GAS VALVE CONTROL WIRING

The suggested schematic wiring diagrams are included. Please use the appropriate one for the installation.

## CSD-1 ROBERT SHAW 7000 DE RHC GAS VALVE CONTROL WIRING

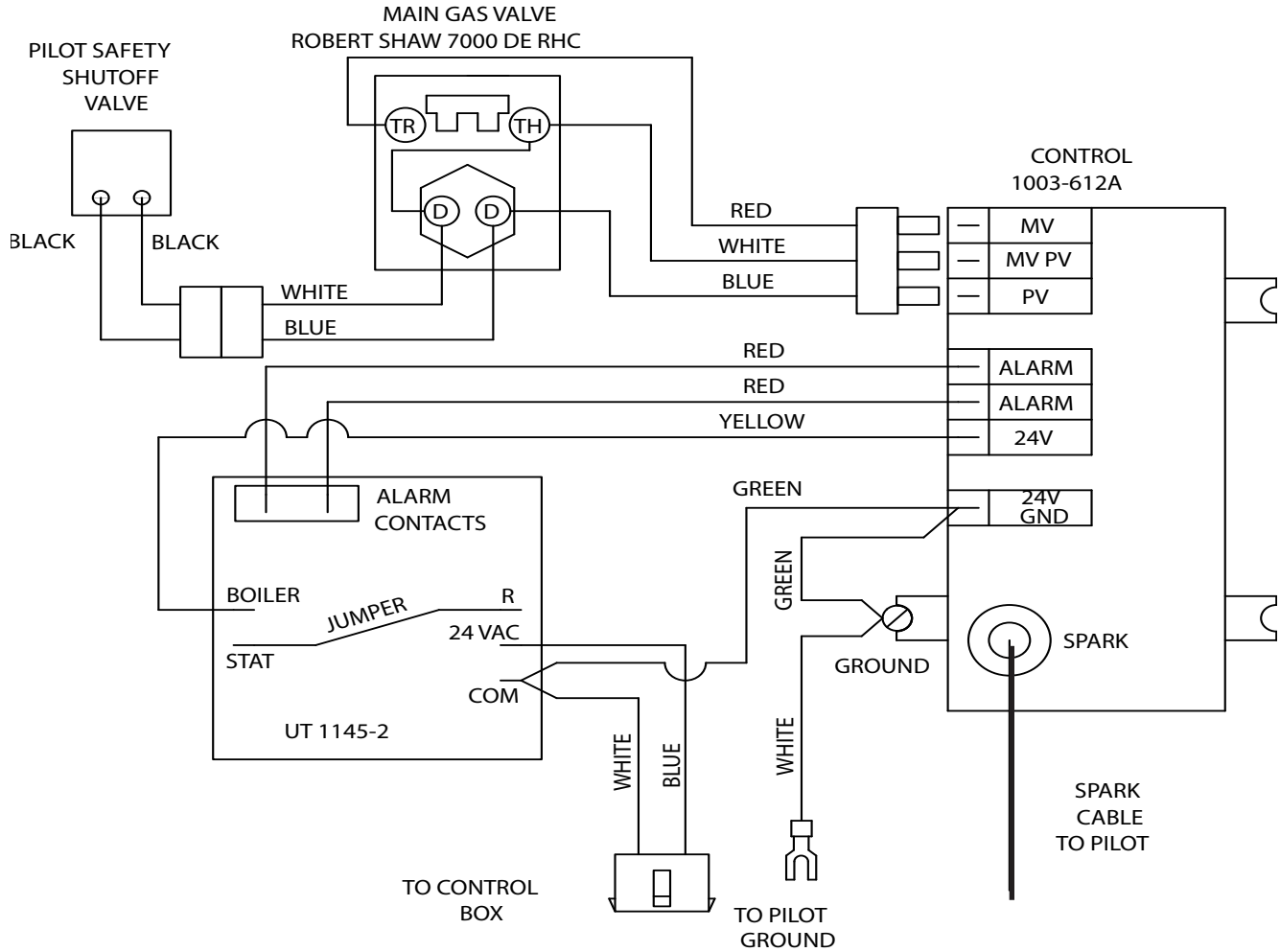

# ELECTRICAL WIRE DIAGRAMS - CSD-1 STEAM BOILERS WITH CONDENSATE PUMP/GRAVITY RETURN KIT # 41257103

COMMERCIAL BOILER, CSD-1 CONTROL, 1-BASE, STEAM, GRAVITY/COND.

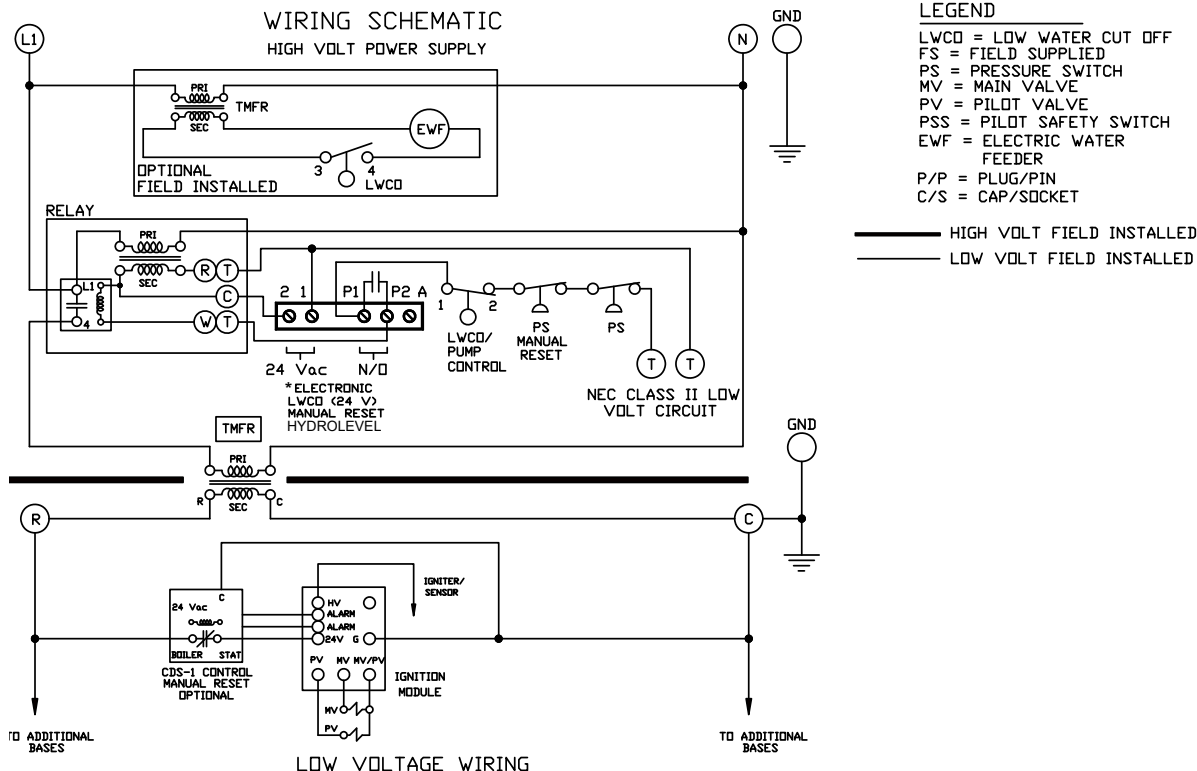
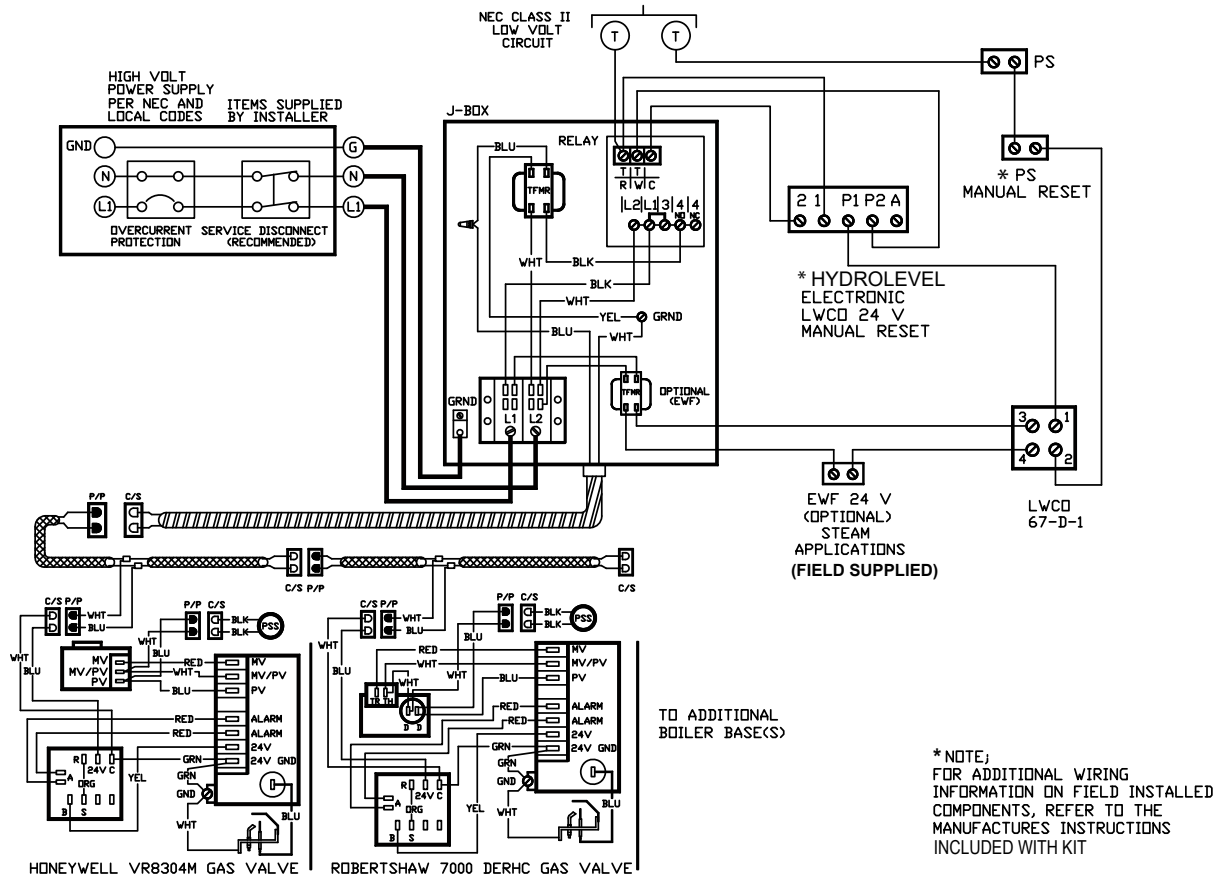

# ELECTRICAL WIRE DIAGRAMS - CSD-1 STEAM BOILERS WITH CONDENSATE PUMP/GRAVITY RETURN KIT # 41257103

COMMERCIAL BOILER, CSD-1 CONTROL, 2-3 BASE, STEAM, GRAVITY/COND.

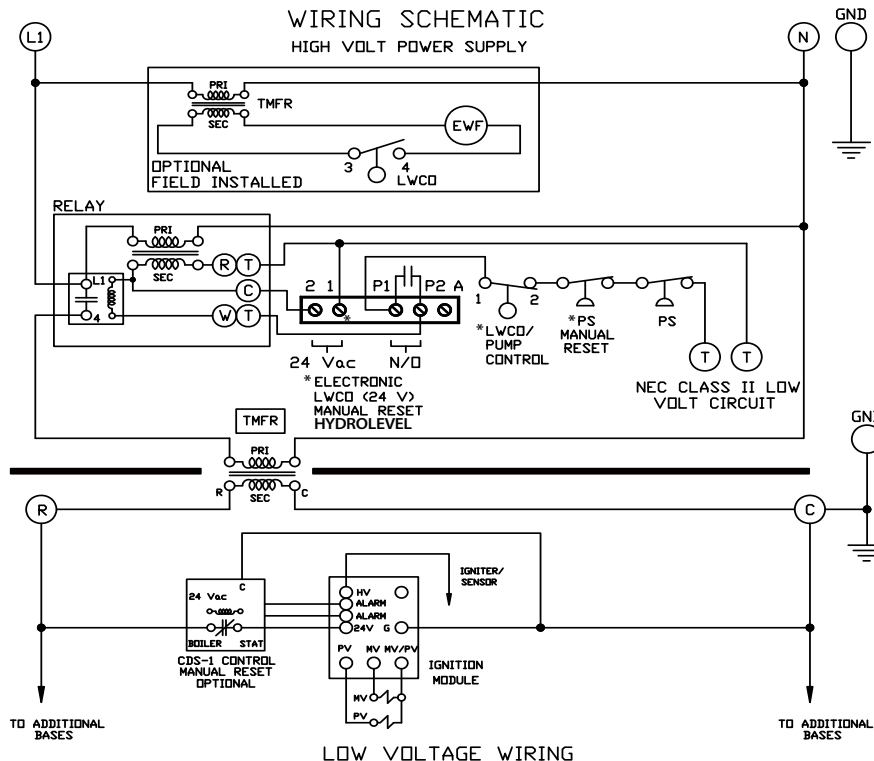
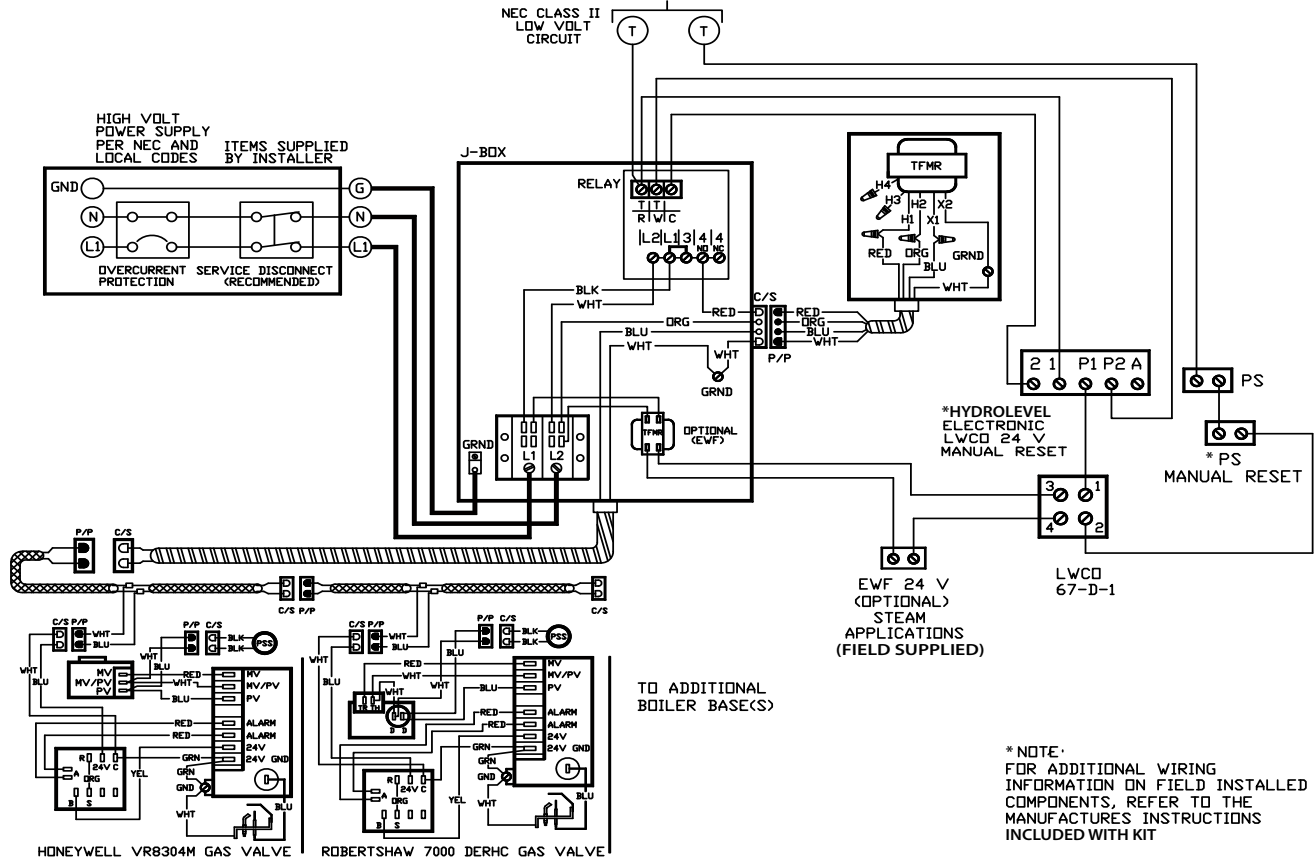

- #### LEGEND
- LWCD = LOW WATER CUT OFF
  - FS = FIELD SUPPLIED
  - PS = PRESSURE SWITCH
  - MV = MAIN VALVE
  - PV = PILOT VALVE
  - PSS = PILOT SAFETY SWITCH
  - EWV = ELECTRIC WATER FEEDER
  - P/P = PLUG/PIN
  - C/S = CAP/SOCKET
- HIGH VOLT FIELD INSTALLED  
 LOW VOLT FIELD INSTALLED

# ELECTRICAL WIRE DIAGRAMS - CSD-1 STEAM BOILERS WITH BOILER FEED PUMP RETURN KIT # 41257104

## COMMERCIAL BOILER, CSD-1 CONTROLS, 1-BASE, STEAM, FEED PUMP

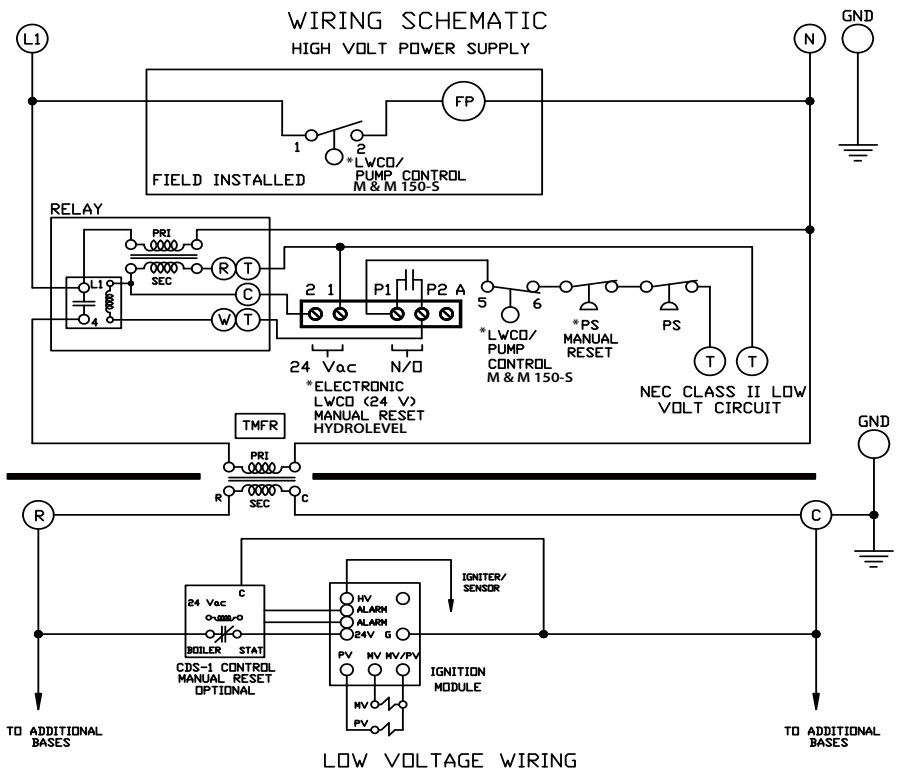
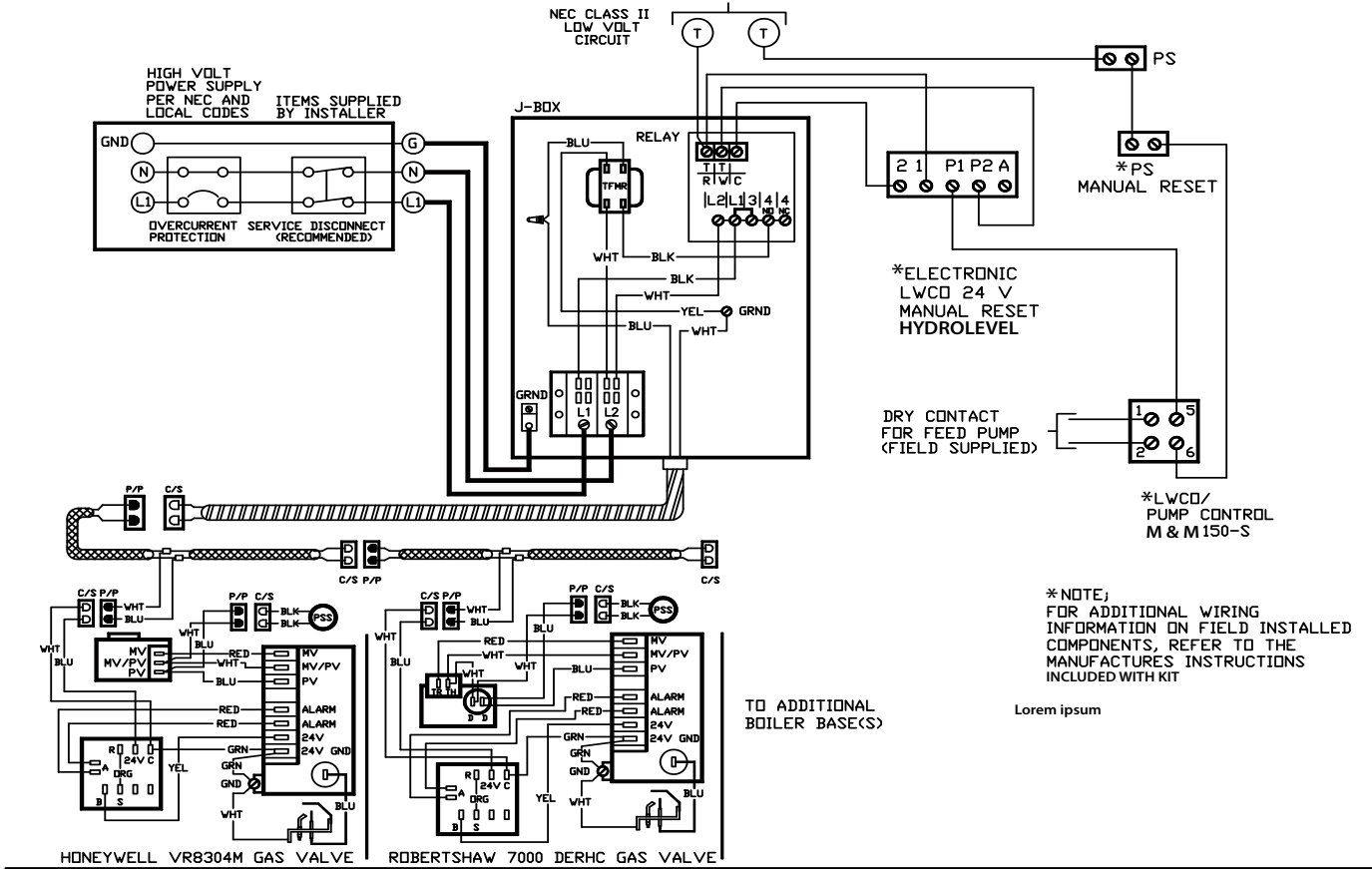

- LEGEND**
- LWCO = LOW WATER CUT OFF
  - PS = PRESSURE SWITCH
  - MV = MAIN VALVE
  - PV = PILOT VALVE
  - PSS = PILOT SAFETY SWITCH
  - FP = FEED PUMP
  - P/P = PLUG/PIN
  - C/S = CAP/SOCKET
- HIGH VOLT FIELD INSTALLED  
 LOW VOLT FIELD INSTALLED

# ELECTRICAL WIRE DIAGRAMS - CSD-1 STEAM BOILERS WITH BOILER FEED PUMP RETURN KIT # 41257104

## COMMERCIAL BOILER, CSD-1 CONTROL, 2-<sup>3</sup> BASE, STEAM, FEED PUMP

