

FLOOR STAND KIT ASSEMBLY INSTRUCTIONS

Kit #240010266

for use with: SSC, VLT, SSV, HX, CHB, CCB, DCC, DCB, MAC, MAH

Kit installation shall be completed by qualified agency.

Figure 1 - Floor Stand Exploded View

⚠ WARNING

Fire, explosion, asphyxiation and electrical shock hazard. Improper installation could result in death or serious injury. Read this instruction and understand all requirements, including requirements of authority having jurisdiction, before beginning installation. Installation not complete until appliance operation is verified per Installation, Operation & Maintenance Manual provided with boiler.

WARNING

This stand is capable of supporting one (1) boiler only. Any changes to this stand or installation could result in serious injury or death.

WARNING

Fire, explosion hazard. Mount boiler vertically or slightly tilted backward to insure proper function of low water cutoff. Failure to follow these instructions could result in death or serious injury.

⚠ CAUTION

Boiler weight exceeds 75 pounds (34 kg). Do not lift boiler onto stand without assistance.

NOTICE

Lift boiler using chassis. Using front jacket, vent piping, water or gas fittings to lift boiler may cause damage to the boiler.

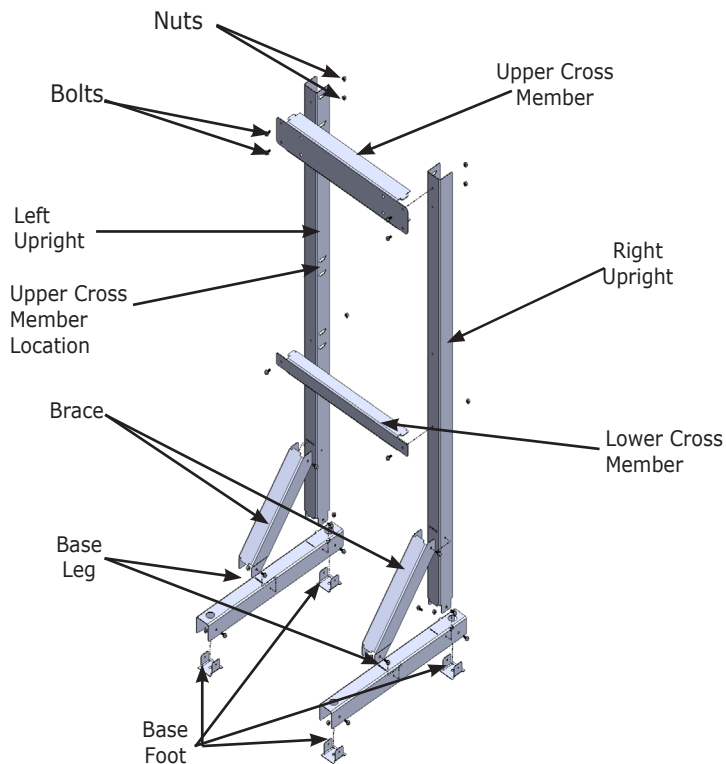

Description	Qty
Left Upright - <i>not interchangeable</i>	1
Right Upright - <i>not interchangeable</i>	1
Base Leg	2
Brace	2
Upper Cross Member	1
Lower Cross Member	1
Base Foot	4
1/4 - 20 x 5/8 Serrated Hex Flange Head Bolt	26
1/4 - 20 Serrated Hex Flange Head Nut	26
5/16 - 18 x 3/4 Serrated Hex Head Bolt (<i>Use for Boiler Wall Mount Bracket attachment</i>)	4
5/16 - 18 Serrated Hex Flange Head Nut (<i>Use for Boiler Wall Mount Bracket</i>)	4
<i>Note: Kit does not include Boiler Wall Mount Bracket (shown in Figure 8) - it is included with your boiler. You will need to locate it for use with this kit (step 9).</i>	

Boiler installation shall conform to requirements of authority having jurisdiction or in absence of such requirements:

- United States
 - National Fuel Gas Code, ANSI Z223.1/NFPA 54.
 - National Electrical Code, NFPA 70.
- Canada
 - Natural Gas and Propane Installation Code, CAN/CSA B149.1.
 - Canadian Electrical Code, Part I, Safety Standard for Electrical Installations, CSA C22.1

Overall Dimension see Figure 9 page 4.

Assembly Instructions

1. Complete assembly of floor stand kit and bolt stand to floor before hanging boiler onto it.
2. Do not tighten bolts until all components are engaged/aligned in place.
3. Attach Base Foot into Left Base Leg at both ends using 1/4-20 x 5/8 Hex Flange Bolts and Nuts. See Figure 2 and 3.
4. Place tapered end of brace on one Base Leg. Insert brace into slot on Base Leg. Attach Left Upright (*not interchangeable*) to Left Base Leg and Brace using 1/4-20 x 5/8 Hex Flange Bolts and Nuts. See Figure 4.
5. Insert Upper Cross Member into upper tab on left upright and push tab down to engage. Screw in place. See Figure 5.

Figure 2 - Left Side Assembly

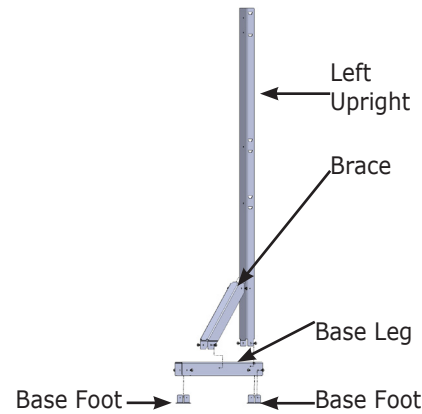

Figure 3 - Foot Attached to Base Leg (View from rear of Leg)

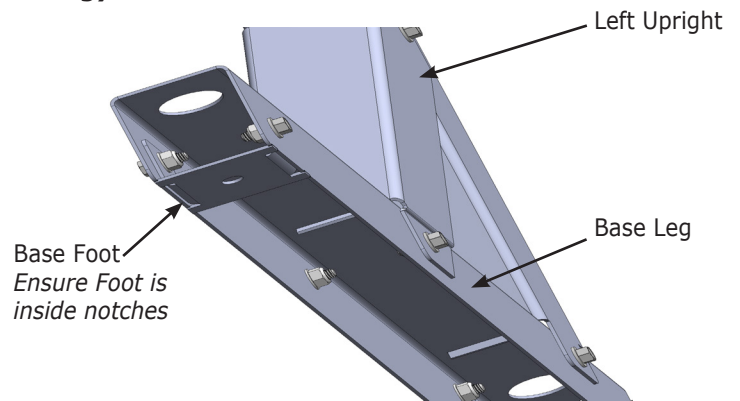

Figure 4 - Brace to Base Leg (View from top/front of Leg)

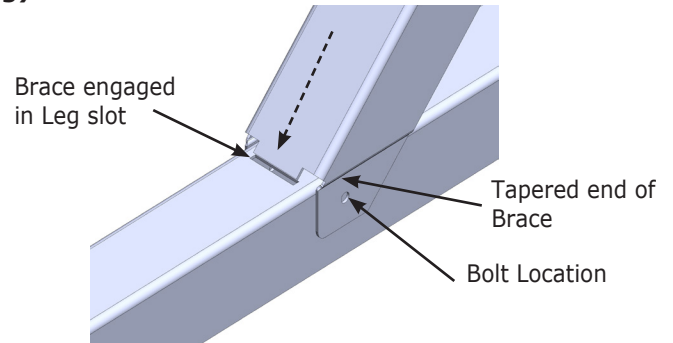

Figure 5 - Upper Cross Member

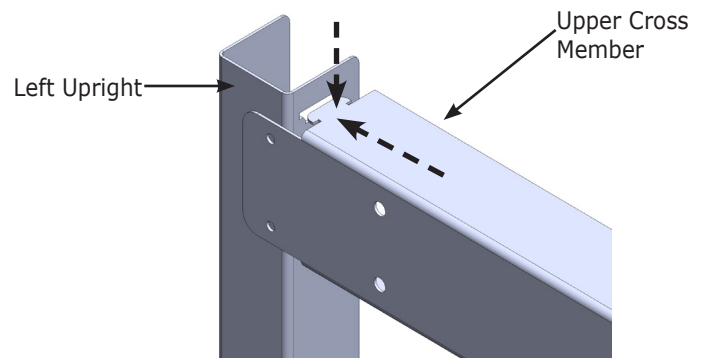

Figure 6 - Cross Member Assembly

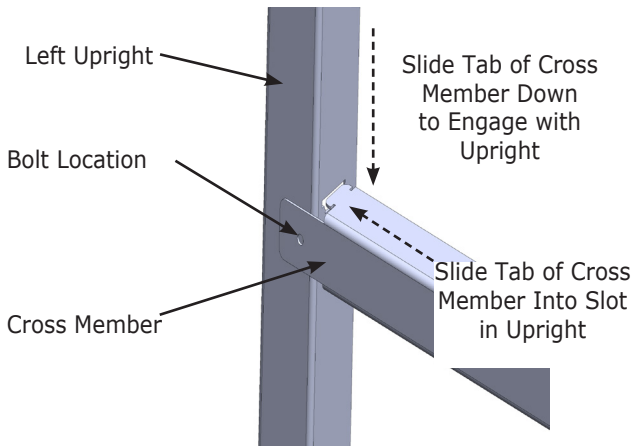

Figure 7 - Cross Member Locations

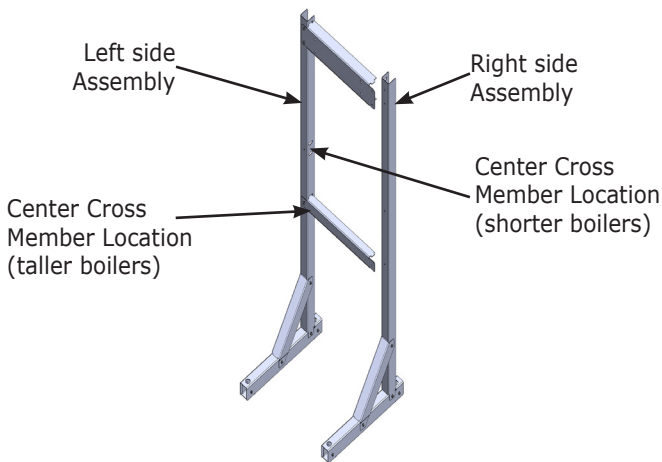
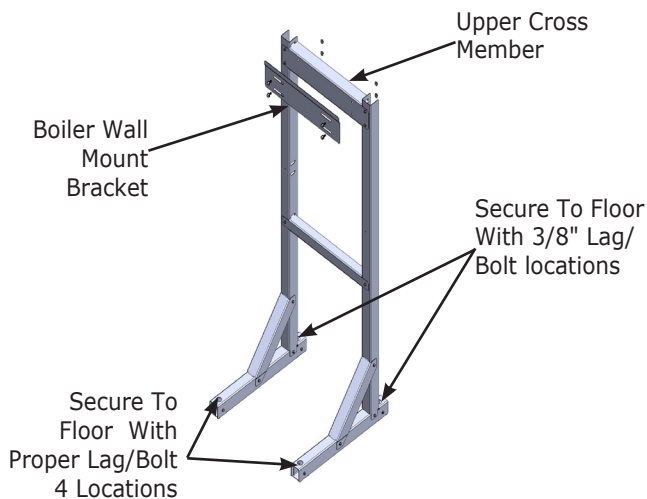

Figure 8 - Boiler Wall Bracket to Floor Stand



6. Position of Lower Cross Member is determined by position of boiler back support location. Boiler back support *must* come in contact with Lower Cross Member.

Insert Lower Cross Member into tabs of Left upright.

Example: Model SSC - Center tabs on uprights are for 50-100 model boilers. Lower tabs on uprights are for 150-299 model boilers.

Slide Cross Member down to engage Cross Member with Upright. Screw in place with 1/4-20 x 5/8 Hex Flange Bolts and Nuts. See Figure 6 and 7.

7. Assemble Right Upright Assembly using same procedure used for left upright assembly. Use remaining parts - 2 Base Feet, 1 Base Leg, 1 Brace, Right side Upright and bolts and nuts. See Figure 7.
8. Engage Right Side Assembly with Cross Members already assembled on to Left Side Assembly. Tighten all bolts and nuts in floor stand assembly (13 pair of bolts and nuts).
9. Install wall bracket received with your Boiler to Upper Cross Member of floor stand using supplied 5/16-18 bolts and nuts. See Figure 8.

⚠ WARNING
<p>Fire, explosion, asphyxiation and electrical shock hazard. Improper installation could result in death or serious injury. Securely fasten stand to floor before mounting boiler to stand. Failure to follow these instructions could result in death or serious injury.</p>

10. Use proper lag/bolts (not included) to secure Stand to floor. See Figure 8. It is installer's responsibility to determine proper lag/bolts based on actual floor type and condition.
11. Complete Boiler installation following instructions found in the Installation, Operation and Maintenance Manual provided with your boiler.

Dimensions

Figure 9 - Overall Stand Dimensions

