

SUPPLEMENTAL INSTRUCTIONS:

DIRECT VENT

INSTRUCTIONS FOR HIGH EFFICIENCY OIL-FIRED HOT WATER BOILER



Information contained in this manual pertains to direct vent boilers equipped with manufacturer installed blocked vent safety control system (pressure switch).

⚠ WARNING
<p>Installations of venting shall be done only by a qualified expert and in accordance with these instructions. Venting a boiler or any other oil appliance with improper methods or materials may result in serious injury or death due to fire or to asphyxiation from poisonous gases such as carbon monoxide which is odorless and invisible.</p>

Keep area around vent terminal free of snow, ice, and debris.

Direct Venting Of Oil Fired Boilers	2
Vent Terminal Locations.....	3
Vent Terminal Installation	4
Intake Air Pipe Installation.....	5
Vent Pipe Installation	6
Vent Pipe Installation	7
Blocked Vent Safety Shutoff System.....	8
Sequence Of Operation	9
Final Check Out.....	10
Burner Settings Tables	11
Burner Settings Tables	12
Wiring Diagrams.....	13
Operation And Troubleshooting.....	16

DIRECT VENTING OF OIL FIRED BOILERS

Introduction

- Direct Vent refers to sealed combustion system.
- Draft regulator (furnished with standard chimney vent boiler) is not used for direct venting.
- Direct Vent series is ideal for applications where a conventional chimney is unavailable, not easily installed; electrically heated home being retrofit for oil forced air heating for example.
- Direct vented appliances require planning, the range of flue lengths is restricted, clearances are critical, and national and local codes are strict with respect to safety.
- Be sure the Boiler can be installed within homes physical limitations, and accordance with local codes and regulations. Physical limitations include sufficient clearance to grade. Avoid vent termination locations subject to frequent strong wind gusts.
- See Table 1 for approved venting.

Oil Burners

Beckett NX and Riello's 40BF series Oil burners, are certified for venting through the wall using ducted outdoor air for combustion.

Standard Beckett AFG Series and Riello 40F Series are not certified for use, in direct vent applications.

The oil burner contains a probe to measure overfire pressure and a pressure switch which does not permit burner to operate if intake or exhaust are blocked.

Vent Terminal Installation Requirements

Through the wall termination installation shall conform to requirements of authority having jurisdiction or in absence of such requirements

- **Canada** Current Edition of Canadian Standards Association CSA B139,
- **United States** ANSI/NFPA 31.

Canadian Installation

Refer to figure 2, vent terminal shall not terminate :

- Directly above paved sidewalk or paved driveway that is located between two buildings, and serves both.
- Less than 7 feet (2.13m) above any paved sidewalk or paved driveway.
- Within 6 feet (1.80m) of a window, door, or mechanical air supply inlet to any building, including soffit openings.
- Above gas/regulator assembly within 3 feet (1m) horizontally of center-line of regulator.
- Within 6 feet (1.80m) of any gas service regulator vent outlet or within 3 feet (1m) of any oil tank vent or any oil tank fill inlet.

- Less than 1 foot (0.3m) above grade level within 6 feet (1.80m) of any combustion air inlet, unless appliance is otherwise certified.
- Within 6 feet (1.80m) of property line.
- Underneath veranda, porch, or deck.
- So the flue gases are directed at combustible material or at any openings of surrounding buildings that are within 6 feet (1.80m).
- Less than 3 feet (1m) from inside corner of L-shaped structure.
- So the bottom of the vent termination opening is less than 1 foot (0.3m) above any surface that may support snow, ice, or debris.
- So the flue gases are directed towards bricks, siding, or other construction, in such a manner that may cause damage from heat or condensate from flue gas.
- Within 4 feet (1.2m) of power venter.

USA Installation

Refer to figure 3, vent terminal shall not terminate:

- Less than 7 feet (2.13m) above any adjacent public walkway.
- Less than 4 feet (1.22m) below, 4 feet horizontally, or 1 foot (0.3m) above door, window, or gravity air inlet of the structure.
- Less than 1 foot (0.3m) above grade.
- Less than 1 foot (0.3m) from soffit or roof of structure.
- Less than 3 feet (0.9m) from inside corner of L shaped structure.
- Less than 5 feet (1.6m) of gas regulator vent outlet, or oil tank vent outlet.
- Underneath veranda, porch or deck.

Figure 1 - Standard Vent Terminal Assembly



VENT TERMINAL LOCATIONS

Figure 2 - Vent Terminal Locations (Canada)

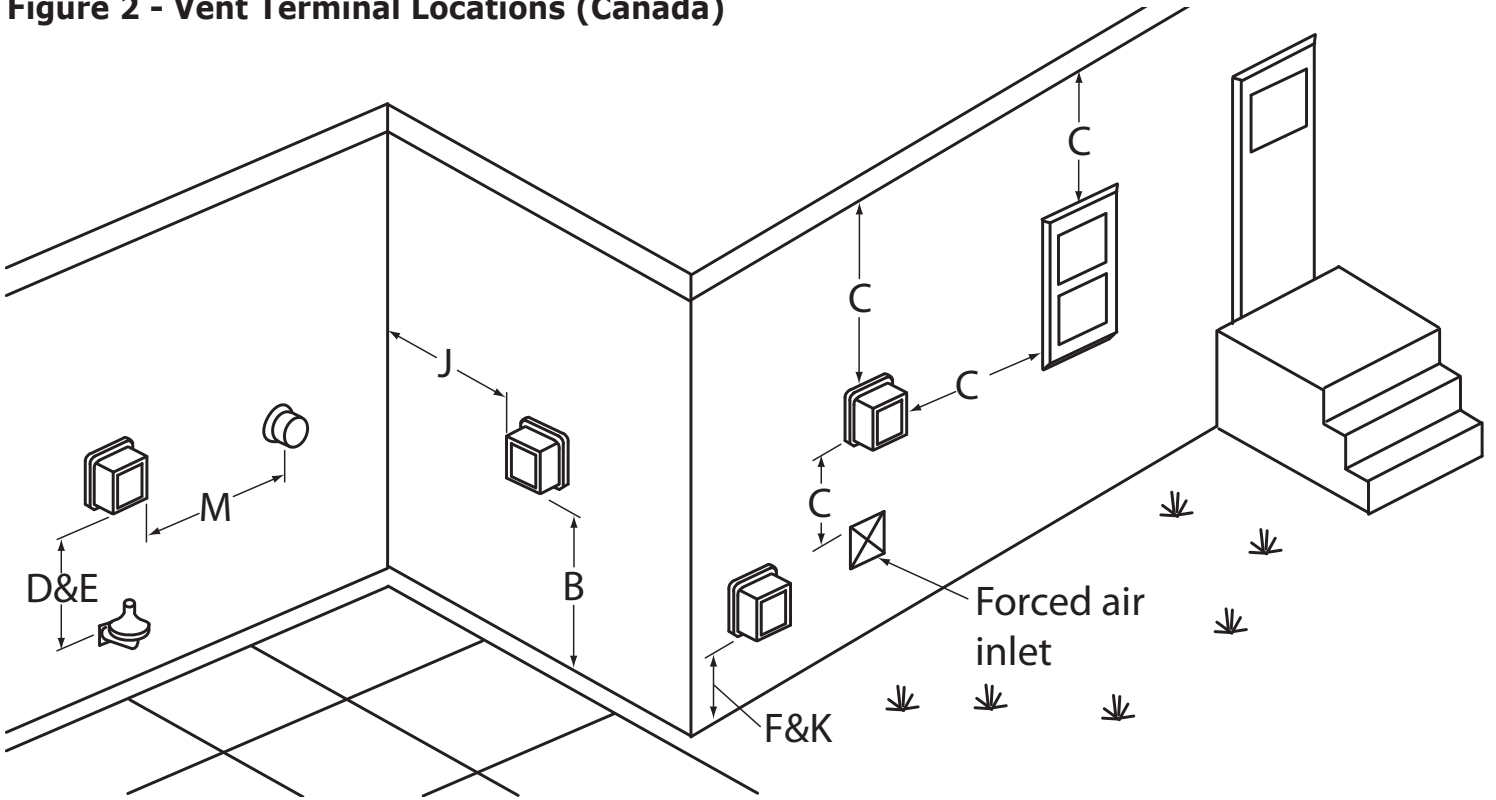
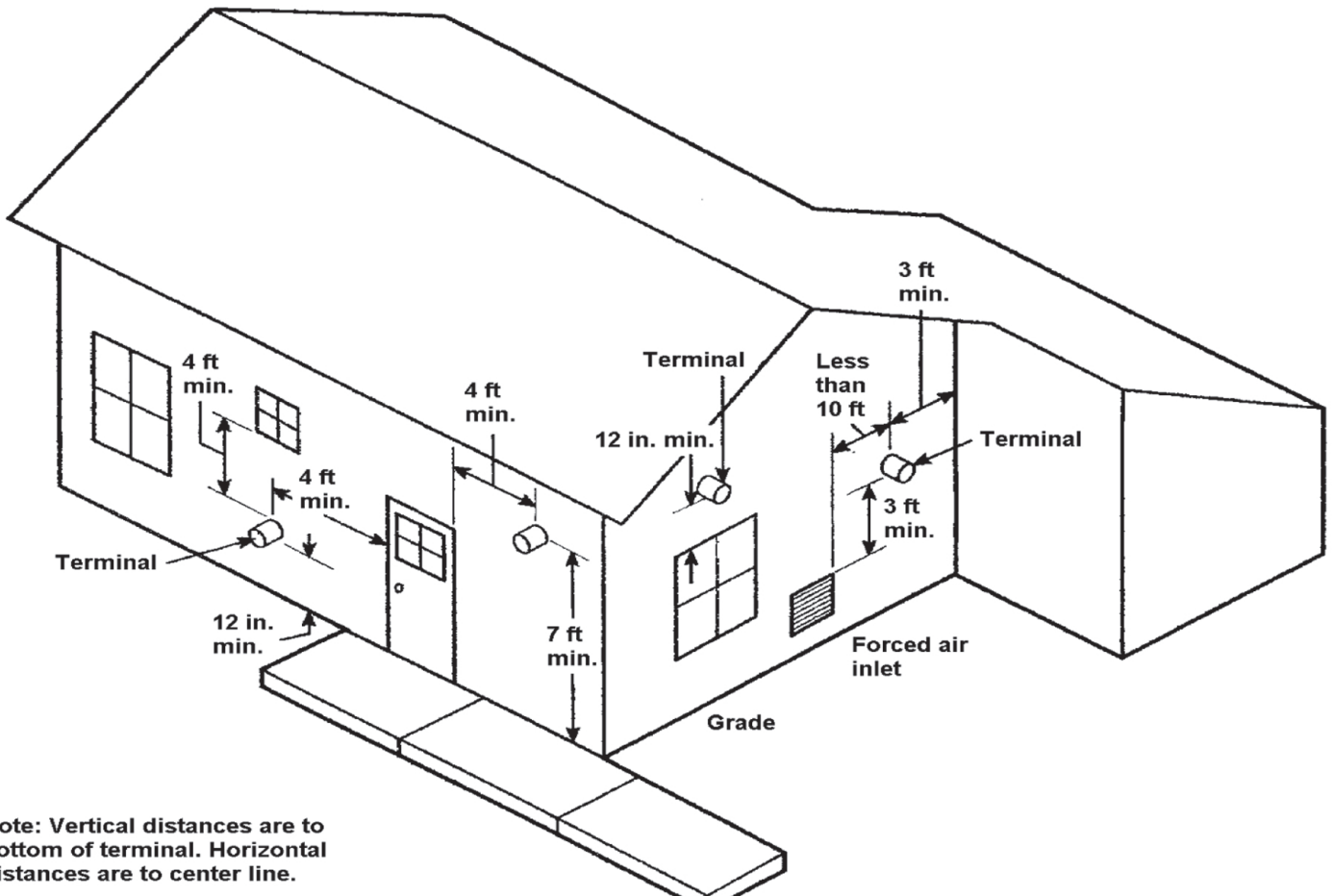

Figure 3 - Vent Terminal Location (USA)



Note: Vertical distances are to bottom of terminal. Horizontal distances are to center line.

VENT TERMINAL INSTALLATION

Vent Terminal Location

See table 1 for equipment certified for use with this appliance.

Select location of wall penetration that conforms to code for exterior location:

1. As close to appliance as possible,
2. Maintains clearance to combustibles,
3. Maintains minimum 1/4 inch per foot slope back to appliance.
4. Install vent terminal in wall having minimum thickness of 5", and maximum thickness of 10".

Vent Terminal Installation

- Cut a 6-1/2" diameter hole through the wall.
- Remove Intake Air Sleeve from Terminal.
- Insert Terminal through the wall from outside, secure with 4 screws to the wall, and seal to wall with weatherproof sealant.
- From inside the building, re-attach Intake Air Sleeve and secure inner sleeve to outer sleeve with 2 screws.
- Use 4 screws to secure Sleeve to wall. See Figure 4.
- Insure Intake Air Connector is located for easy attachment and complies with code.

Vent Terminal Riser Kit

Kit is designed to increase height of vent terminal by approximately 3 feet.

Ideal where excessive snow build up could occur or where more flexibility is required to maintain minimum clearances at grade. See figure 5.

Figure 4 - Inside View of Vent Terminal



Figure 5 - Vent Terminal Riser

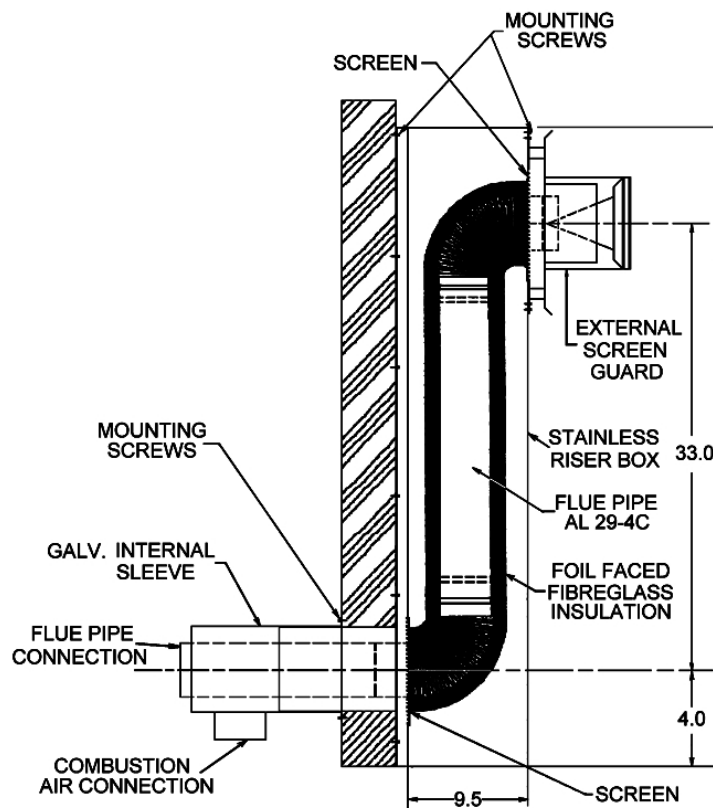

Direct Vent Intake Air Pipe Installation

Do not use Flexible duct for combustion air.

Outdoor air for combustion must be used.

Oil burners approved for use with outdoor air for combustion are Beckett NX and Riello 40BF.

Outdoor air is obtained using the following materials/methods.

Acceptable combustion air intake materials are listed below.

Beckett NX Burner :

- 4 inch "C" Vent (single wall galvanized).
- 4 inch Rigid Aluminum pipe (0.030" wall thickness).

Riello 40BF Burner :

- 4 inch "C" Vent (single wall galvanized).
- 4 inch Rigid Aluminum pipe (0.030" wall thickness). Use 4 inch pipe from the terminal to appliance. Reduce to 3 inch pipe to attach to burner inlet collar.

NOTICE

Seal intake pipe and fittings with foil tape, duct tape, or silicone caulking and attached mechanically with screws.

Maximum combustion air intake length is 25 feet using eight 90° elbows. Combustion air intake does not have minimum length.

Condensation may become a concern during some climatic conditions. It may be necessary to wrap a portion, or entire intake piping (particularly metal intake piping) with waterproof insulation material.

Venting Installation - Direct Vent

⚠ WARNING

Improper installation, adjustment, alteration, service or maintenance could result in death or serious injury. Do not enclose vent.
Do not route vent through walls, floors or ceilings. Venting and vent terminal are dedicated to the Boiler only; do not attempt to vent any other appliance through it.

Flexible Vent Installation

Supplied flexible exhaust duct is a double wall, one (1) inch clearance to combustibles, flexible venting material.

Inner pipe is constructed of 4 inch inside diameter 316 stainless steel, with two-ply aluminum outer pipe.

High temperature insulation separates inner and outer flex pipes.

Vent installation shall conform to requirements of authority having jurisdiction or in absence of such requirements NFPA 31 Installation Of Oil Burning Equipment (U.S.) or CSA B139 (Canada) and applicable provisions of local building codes and these instructions.

⚠ CAUTION

Use appropriate safety precautions. Thin metal edges are extremely sharp. If not avoided, could result in minor or moderate injury.

1. In as short and straight a run as possible without any unnecessary bends.
2. No dips or sags throughout full length of vent.
3. Slope vent upwards from appliance at least 1/4" per foot.
4. Do not bend vent more than 90°.
5. May cut vent to minimum of 5 feet in length using fine tooth (24 teeth per inch) hacksaw blade.
6. Clean male and female ends of appliance adapter and terminal adapter with residue free brake cleaner solvent.
7. Apply minimum 1/4" bead of Si-Ultra Copper Sealant (provided) onto outside of male end of appliance adapter. Fit adapter to vent by threading it counter clockwise until it stops. Insure joint is not cross threaded. Tighten gear clamp (where provided) on outer cover. See figures 7 and 9.
8. Sheet metal transition ring on boiler flue collar is only used for chimney venting. It is not used for direct venting. The transition ring must be removed from boiler's cast iron flue collar before installing appliance adapter onto the flue collar. Clean off any silicone residue on the flue collar before installing.

Figure 6 - Appliance Connector w/ Test Port

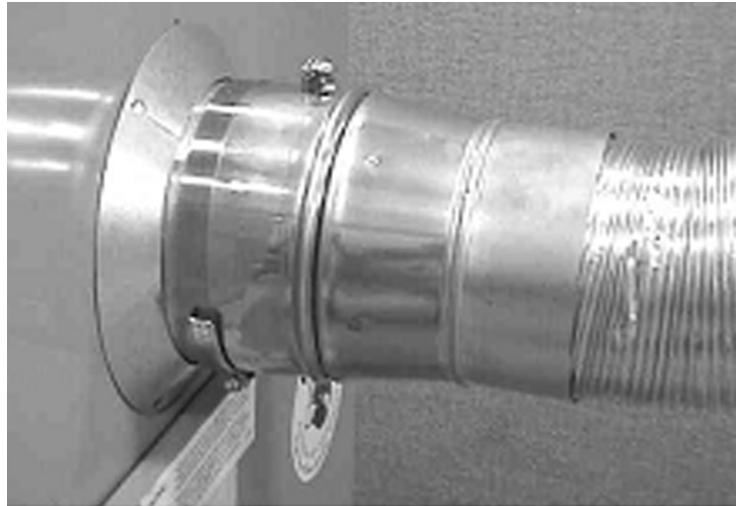
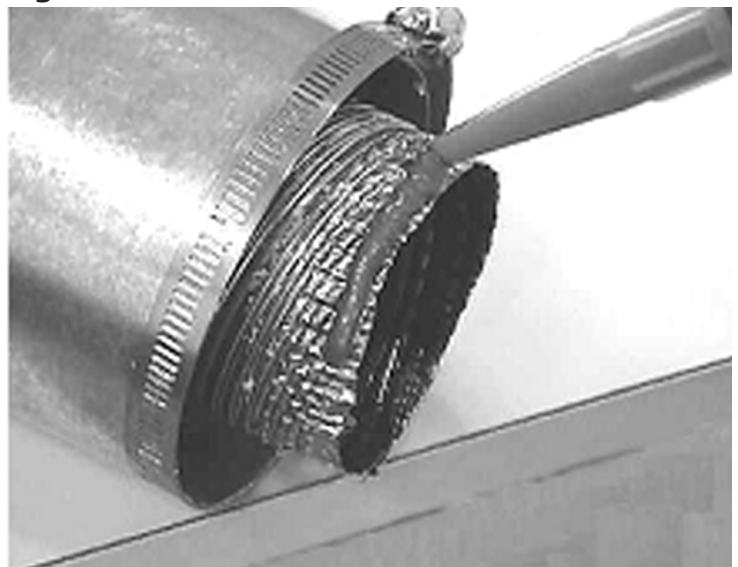

Figure 7 - Male End



VENT PIPE INSTALLATION

9. Apply minimum 1/4" bead of same sealant onto inside of female end of appliance adapter. See figure 8. Slip adapter over appliance flue collar until it stops. Appliance adapter has three screw holes. Attach appliance adapter to flue collar using furnished drill bit to predrill mating holes in flue collar for furnished screws. Vent Connection Kit (drill bit and screws) furnished with vent pipe kit. Predrill to avoid cracking cast iron flue collar.
10. Support Vent every 36" to prevent sagging.
11. Attach terminal adapter to vent and vent terminal similarly to steps 7 and 9 above. Terminal adapter attaches to vent terminal with attached gear clamp.
12. Maximum vent length is 20 feet (using 20 foot vent kit). Piecing vent kits together (i.e. using 2 ten foot kits) is strictly prohibited.

Figure 8 - Female End

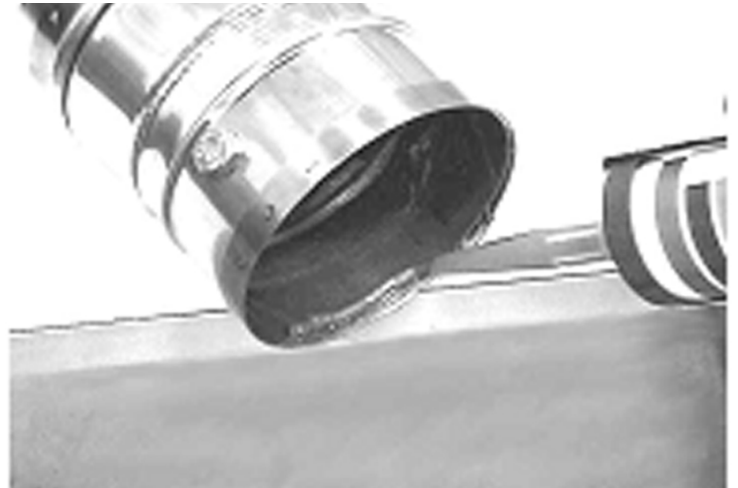

Blocked Vent Safety Shut Off System (BVS)

Oil burners used with this direct vent boiler are equipped with Blocked Vent Safety shutoff system (BVS) using a pressure switch that is part of the oil burner. This safety device shuts off the burner in the event of combustion air blockage or venting blockage. Do not use blocked vent safety switches that are designed for use with chimney vent boilers on direct vent installations.

It is best to have burner shutter and or head settings close to Table 2 or 3.

Beckett NX

BVS pressure switch is wired in series with CAD cell. See Wiring Diagram, Figure 12.

Riello 40BF

BVS pressure switch is wired in series with terminals 10 and 11 on 530SE control. See Wiring Diagram, Figure 13.

Blocked Vent Safety Switch Pressure Tubing Connections

Check tubing connections on all Boilers prior to firing unit. Beckett NX has low and high side tube, vacuum side goes to air intake box, pressure side goes to overfire pressure probe. See Figure 11.

Riello BF low pressure side is open inside air tight burner cover and high pressure side goes to overfire pressure probe.

Verify burner cover is air tight and all hole plugs are in place.

Oil Burner Operation

Once Boiler flue pipe and intake pipe are completely installed. In absence of burner manufacturer's instructions, use following instructions to set burner:

- Shut off electrical power to Boiler.
- Install oil pressure gauge to pressure port on oil pump. (Riello requires special adapter)
- Check air settings for initial firing in Table 2 or 3.
- Restore electrical power to Boiler.
- Start Boiler. Bleed all air from fuel oil lines.
- Close purge valve and fire unit.
- When Boiler has reached "steady state" (after approximately 5 minutes), remove bolt (test port) from center of Appliance Adapter to Boiler.
- Set combustion air control to get TRACE to ZERO smoke.

Beckett NX Burner:

Refer to Table 2. Select head setting according to required firing rate. Final adjustments are required once burner is started.

Final Adjustments

- Tighten lock nuts and screws before making measurements.
- Using suitable testing instruments for CO₂ (or O₂), measure combustion products. CO₂ in the stack should be minimum of 12% CO₂ at a trace of smoke. For clean operation of burner, open air control to introduce enough excess air into the system to reduce CO₂ by 10% of original trace point.

EXAMPLE: 12% CO₂ minus 1.2 (which is 10% of 12) equals 10.8% CO₂.

Riello 40BF Burner:

Refer to Figure 10. Check initial air shutter and head settings. Remove burner cover and turn air shutter adjustment screw (2) until top edge of air shutter (3) is in alignment with corresponding number in Table 3.

NOTICE

Riello burner pressure gauge threads are British Parallel Thread design. Test gauge with NPT fitting ruins pump body. Use Riello pressure gauge or adapter.

Further adjustments must be made with burner cover in place by unscrewing plug on cover. Turn screw clockwise to increase combustion air or counter clockwise to decrease combustion air.

- Shutter final position will vary on each installation.
- Use instruments to establish proper settings for maximum CO₂ and smoke spot reading of zero.
- Re-insert plastic cap over air adjustment hole before any measurements.

SEQUENCE OF OPERATION

Beckett NX

1. Room temperature drops, thermostat calls for heat.
2. Pre-purge begins, lasting 5 to 15 seconds.
3. Oil solenoid and BVS are energized
4. Oil Solenoid opens allowing oil to reach Burner Electrodes. Burner ignition begins.
5. If vent is clear, pressure switch closes, Cad cell detects light from combustion the primary control safety circuit disconnects allowing combustion to continue. BVS is energized.
6. After 15 to 45 seconds (depending on primary control characteristics), electric spark across electrode tips stops, combustion continues.
7. Boiler continues operation and reaches "steady state", point at which system temperature stabilizes.
8. Room temperature rises, thermostat is satisfied, heating contacts open.
9. Oil solenoid valve closes, combustion stops, burner motor remains on to complete Post Purge Cycle. Post Purge time can be 0 to 8 minutes depending on settings. Factory default is 30 seconds. Timing can be changed using Beckett 5206 Genisys display.
10. Boiler remains idle until next call for heat.

Riello 40BF

1. Room temperature drops, thermostat calls for heat.
2. Pre-purge begins, lasting 5 to 15 seconds. BVS is energized.
3. If flue is clear, pressure switch allows ignition sequence to continue.
4. Oil Solenoid opens allowing oil to reach burner electrodes. Burner ignition begins.
5. Cad cell detects light from combustion, disconnects primary control safety circuit, allowing combustion to continue.
6. After 15 to 45 seconds (depending on primary control characteristics), electric spark across electrode tips stops, combustion continues.
7. Boiler continues to operate and reaches "steady state", the point at which the system temperature stabilizes.
8. Room temperature rises, thermostat is satisfied, heating contacts open.
9. Oil solenoid valve closes, combustion stops, burner motor remains on to complete post purge cycle. Post purge time can be 10 seconds to 5 minutes depending on settings. Factory default is 30 seconds. Timing can be changed by rotating dial on Riello burner fan-off timer control board.
10. Boiler remains idle until next call for heat.

Figure 9 - Flex Vent Assembly Detail

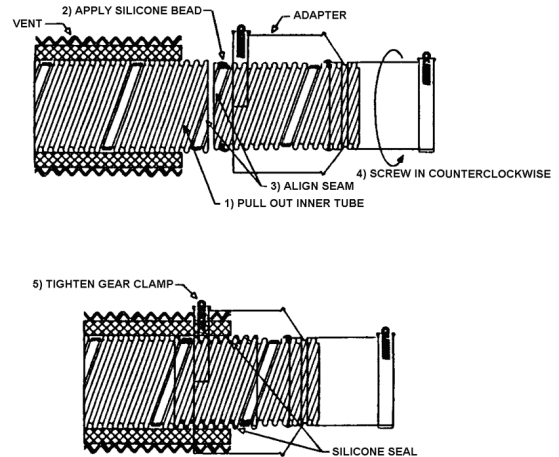
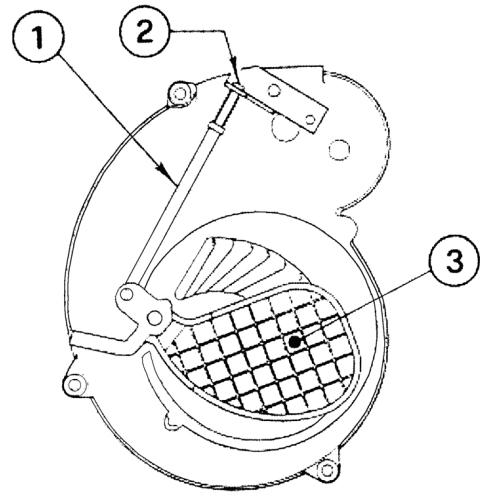

Figure 10 - Air Shutter Setting



FINAL CHECK OUT

- Carefully examine complete vent system for leaks. This may be done by spraying soapy solution on all joints and watching for bubbles during pre-purge. The hot vent can be checked with lit taper for signs of air movement around joints or seams.
- Insure all safety devices and electrical components have been set for normal operation. Insure all electrical connections are tight and wiring is secure.
- Insure homeowner is informed and understands the following:
 1. Where circuit breaker or fuse is located in main electrical panel.
 2. Where Boiler switch is located, and switch "on" and "off" positions if not obvious.
 3. Where oil shut-off valve from oil storage tank is located.
 4. To keep area around vent terminal free of snow, ice, and debris.
 5. How to operate the thermostat, and other related accessories.
 6. How to operate manual reset button on primary control, and especially when not to push the reset button.
 7. How and where to visually inspect the venting system for leaks or other problems.
 8. How to inspect, clean and replace the air filter, and other homeowner maintenance procedures.
 9. Who to call for emergency service and routine annual service.
 10. Terms and conditions of the manufacturer's warranty and the contractor's warranty.

BURNER SETTINGS TABLES

TABLE 1: THIS HIGH EFFICIENCY BOILER IS CERTIFIED FOR USE AS DIRECT VENT BOILER ONLY WITH THE FOLLOWING PART NUMBERS

Oil Burner Options	Beckett NX per Table 2
	Riello 40BF per Table 3
Vent Terminal Options	Standard P/N 28972
	36" Riser P/N 29231
Vent Pipe Kit Options	4" x 10' P/N 550003419
	4" x 15' P/N 550003420
	4" x 20' P/N 550003421
Vent Pipe Kit Includes:	Specified Length of Double Wall Vent Pipe
	Appliance Adapter 240007535
	Terminal Adapter 240006914
	High Temperature Sealant
	Vent Connection Kit
	Direct Vent Supplemental Instructions
Field Supplied Items:	
- Single Wall 4" Vent Pipe 25 Foot Max with up to Eight (8) 90° Elbows for Intake Air Pipe	
- 4" x 3" Single Wall Reducer for Intake Air Pipe Connection to Riello Burner	

TABLE 2: BECKETT DIRECT VENT PRELIMINARY BURNER SETTINGS

Boiler Model	Head Type	Insertion Depth	Firing Rate [GPH]	Combustion liner	Nozzle Mfr.	Nozzle Type	Pump Pressure [PSI]	Air Setting	Pressure Switch Setpoint	Rated AFUE Efficiency [%]
4075	6 Slot	2.5"	0.75	Oval	Delavan	0.60x60B	150	1.5	0.65" WC	86.0
4095	6 Slot	2.5"	0.95	Oval	Hago	0.75x60B	155	4.0	0.65" WC	85.0
5100	6 Slot	2.5"	1.00	None	Delavan	0.75x45B	175	4.0	0.85" WC	86.5
5115	6 Slot	2.5"	1.15	V5	Hago	1.00x60B	140	1.8	0.85" WC	85.0
5135	6 Slot	2.5"	1.35	V5	Delevan	1.10x60B	150	2.5	0.85" WC	84.0
6130	9 Slot	2.5"	1.30	V6	Danfoss	1.00x45B	175	2.0	0.65" WC	86.5

Timings

Pre-purge	15 seconds
Post-Purge	30 seconds

TABLE 2: BECKETT/ECR PART NUMBERS

Boiler Model	Beckett Oil Burner Model	ECR Oil Burner Part Number
4075	NX70LC	240007531
4095	NX70LC	240009393
5100	NX70LC	240007532
5115	NX70LF	240009395
5135	NX70LF	240009396
6130	NX70LD	240007533

BURNER SETTINGS TABLES

Table 3: RIELLO 40BF DIRECT VENT PRELIMINARY BURNER SETTINGS

Boiler Model	Head Type	Insertion Depth	Firing Rate [GPH]	Combustion Liner	Nozzle Mfr.	Nozzle Type	Pump Pressure [PSI]	Head Setting	Air Setting	Pressure Switch Setpoint	Rated AFUE Efficiency [%]
4075	Reverse	2.75"	0.75	Oval	Delavan	0.65x60W	150	3	5.0	0.25" WC	86.0
4095	Standard	1.75"	0.95	Oval	Delavan	0.75x90B	175	1	4.0	0.25" WC	85.0
4110	Standard	1.75"	1.10	Oval	Delavan	1.00x90B	125	2	5.0	0.25" WC	84.0
5100	Standard	2.75"	1.00	None	Delavan	0.75x60B	175	1	5.0	0.80" WC	86.5
5115	Standard	1.75"	1.15	None	Delavan	1.00x80B	130	2	5.8	0.80" WC	85.0
5135	Standard	1.75"	1.35	None	Delavan	1.20x80B	125	4	5.8	0.80" WC	84.0
6130	Standard	2.75"	1.30	V6	Delavan	1.00x45B	175	2	8.0	0.90" WC	86.5

Timings

Pre-purge	12 seconds
Post-Purge	30 seconds

Boiler Model	Riello Oil Burner Model	ECR Oil Burner Part Number
4075	40BF3	240007528
4095	40BF5	240009407
4110	40BF5	240009408
5100	40BF5	240007529
5115	40BF5	240009409
5135	40BF5	240009410
6130	40BF5	240007530

Figure 11 - Beckett NX With Blocked Flue Pressure Switch Safety

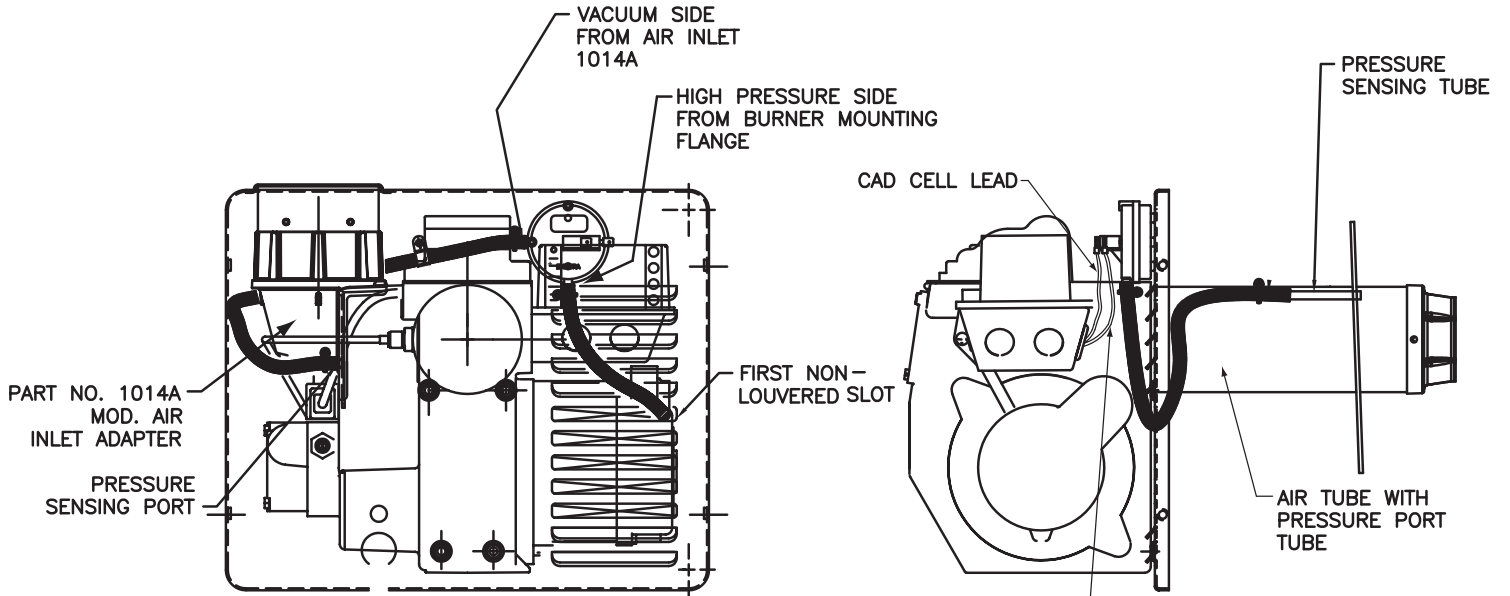

- NOTES:
1. HOSE CLAMPS TO BE INSTALLED ON:
 - (1) PRESSURE SENSING TUBE
 - (2) PRESSURE SWITCH, BOTH PORTS
 - (1) 1014A PRESSURE SENSING PORT
- POSITION CLAMP WHERE TUBE IS OVER PORT. LIGHTLY TUG TO CONFIRM THAT ITS SECURE.

WIRING DIAGRAMS

Figure 12 - Wiring Diagram: Beckett NX With Genisys™ 7505 (15 Seconds pre purge, 2 minutes post purge)

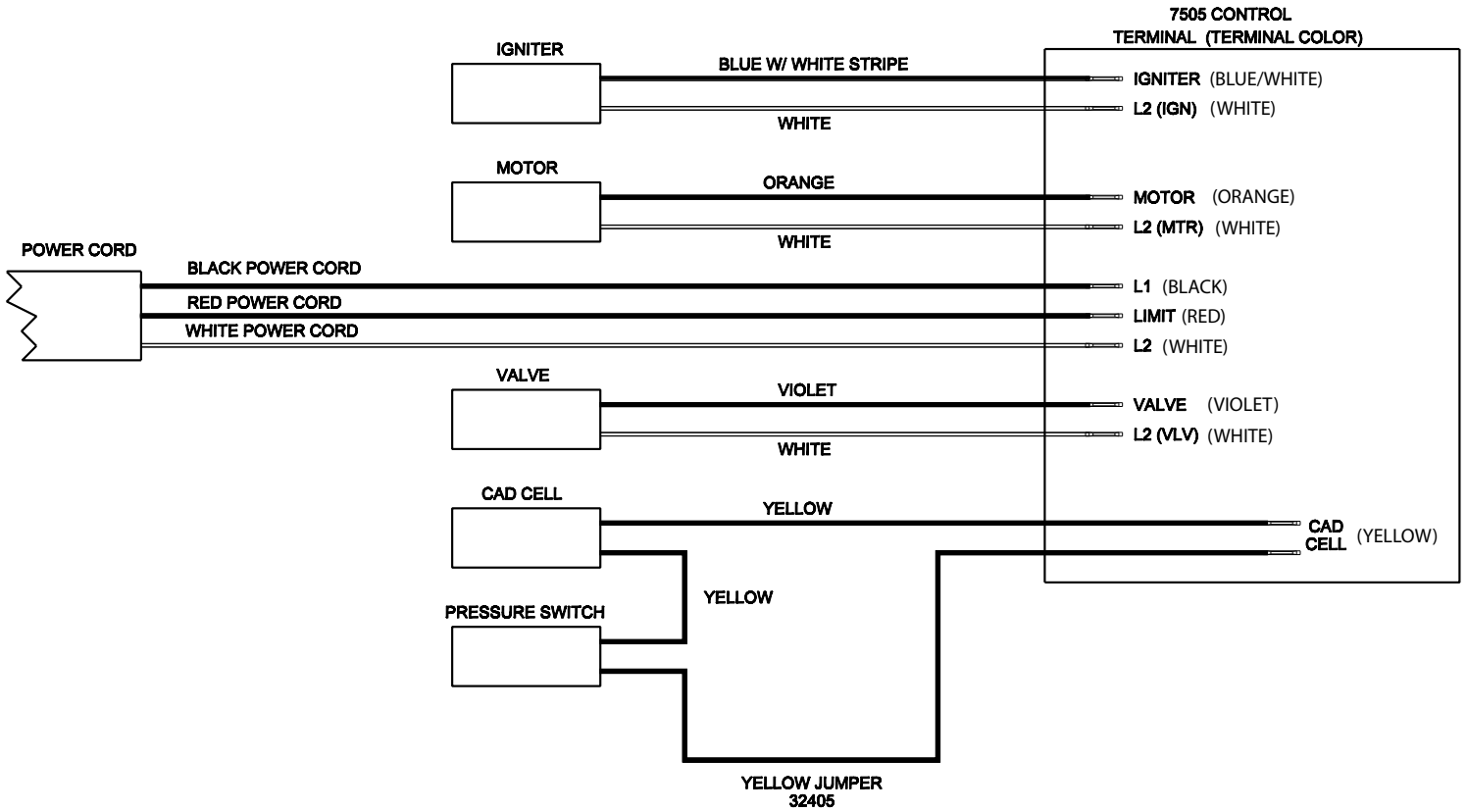
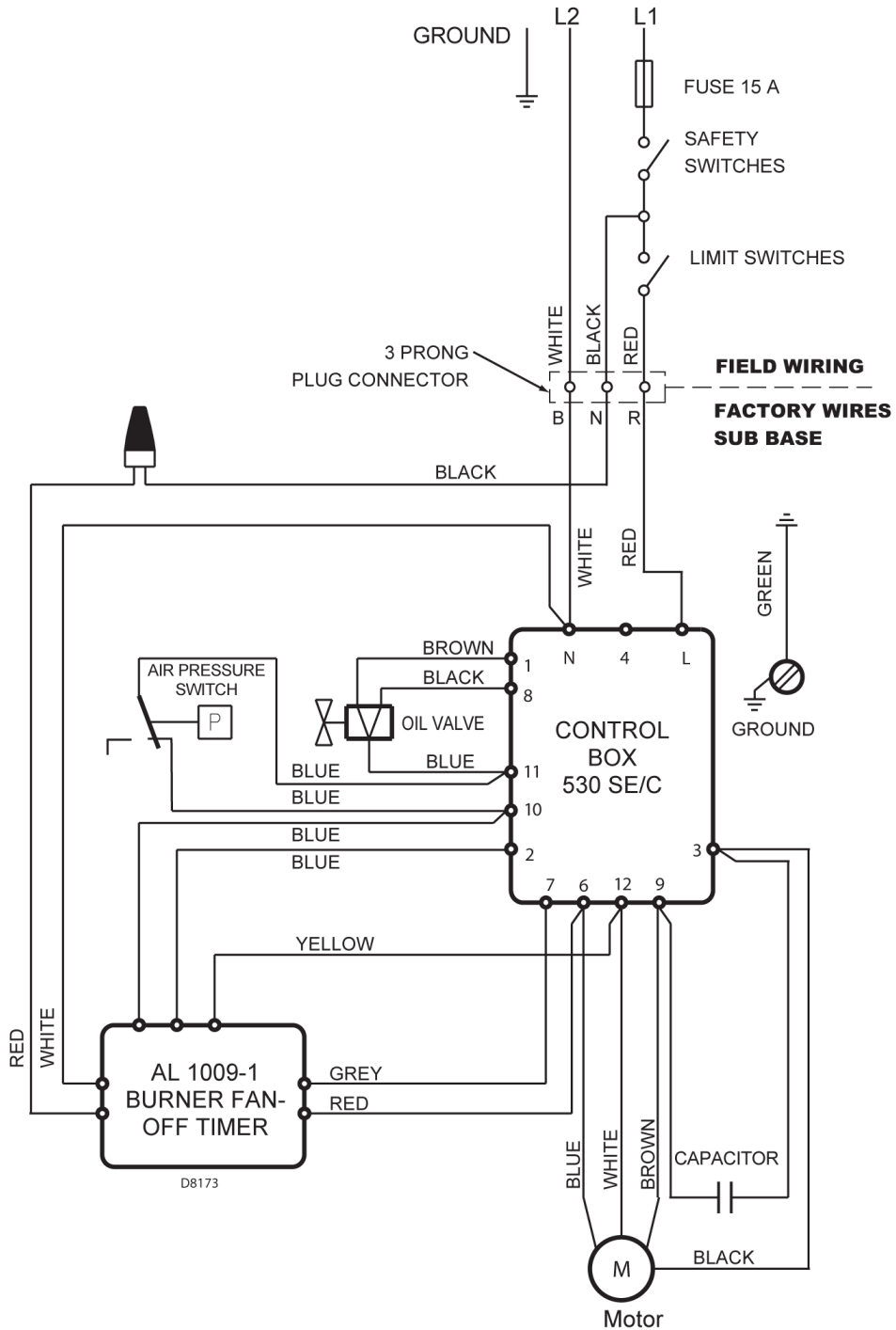

Figure 13 - Riello Wiring Diagram With Post Purge Timer And Blocked Flue Pressure Switch Safety

The safety switch in the 530SE CONTROL BOX is equipped with a contact allowing remote sensing of burner lockout. The electrical connection is made at terminal 4 (o) on the SUB-BASE.

Should lockout occur the 530SE CONTROL BOX will supply a power source of 120VAC to the connection terminal. The maximum allowable current draw on this terminal (4) is 1 Amp.



If a neutral or ground lead is attached to terminal 4, the CONTROL BOX on the burner will be damaged should lockout occur.

OPERATION AND TROUBLESHOOTING

NX Burner With Blocked Vent Safety (BVS) Operation	
External Action	Appliance Response
Power applied to burner control	Internal safety check conducted. If no light or flame is detected and all internal conditions are correct, control enters idle mode.
Thermostat Calls For Heat	<ol style="list-style-type: none"> 1. Contacts between T and T on Aquastat L7248A are closed. 2. Burner Control period (4 seconds) internal and external check for flame or light. If flame is detected, control remains in idle mode. 3. When flame is not present, Burner Control will apply power to the burner motor and igniter, complete a 15 second valve on delay period and then apply power to the oil valve circuit. 4. Burner Control enters the trial for ignition period. <ol style="list-style-type: none"> A. Monitors burner for flame. B. When flame is not detected: <ol style="list-style-type: none"> I. Enters lockout mode after 15 seconds. II. Shuts off valve, igniter and burner motor. III. Flashes indicator light at 1 Hz (½ second on, ½ second off). IV. Depress reset button to return to power up sequence. C. When flame is detected, Carry-Over period begins: 5. Burner Control enters 10-second Ignition Carry-Over period. <ol style="list-style-type: none"> A. Turns on indicator light B. If flame is lost and lockout time has not expired, Burner Control returns to trial for Ignition period. C. If flame is lost and lockout time has expired, Burner Control enters Recycle Mode. 6. Carry-over time expires and igniter turns off. 7. Enters a run mode: <ol style="list-style-type: none"> A. Flame is monitored until call for heat ends or flame is lost. If flame is lost: B. Control enters Recycle Mode. <ol style="list-style-type: none"> I. Recycle time starts (60 seconds). II. Burner and valve are turned off. III. Indicator light flashes at ¼ Hz (2 seconds on, 2 seconds off). IV. Returns to Idle mode at end of Recycle mode.
Call for heat is satisfied.	<ol style="list-style-type: none"> 1. Oil valve circuit is de-energized and valve shuts off. 2. Burner motor runs for selected post purge time. 3. Burner motor turns off. 4. Burner Control returns to Idle mode
Reset button pushed two times without device completing a call for heat.	<ol style="list-style-type: none"> 1. Burner Control enters restricted mode. 2. Indicator light flashes 1 Hz (½ second on, ½ second off). 3. Reset device by pressing and holding reset button for a minimum of 45 seconds.

GeniSys 7505 Reset Button Operations

Pushing the reset button in the current state will cause the following conditions:

If the burner state is:	Pushing the reset button < 1 second	Pushing the reset button > 1 second	Push, hold reset button >15 seconds
Lockout	Reset from Soft Lockout		Reset from Restricted (Hard) Lockout
Valve On Delay, Trial For Ignition, Ignition Carryover	Pump Prime	Disable the Burner. Any time the burner is running, press and hold the reset button to disable the burner. The burner will remain off as long as the button is held.	Enables pump priming: After the reset button has been held for 15 seconds the button can then be clicked during the next ignition sequence to enter pump prime mode.
Run (igniter is shut off)	Yellow light flashes to indicate cad cell resistance.		
Motor-Off Delay, Standby	No action		
Pump Prime	No action	Exit pump prime mode and return to standby.	

Status Lights

Light Color	On Continuously	Flashing
Red	Restricted (Hard) Lockout	Soft Lockout
Green	Flame Sense during normal operation. May be stray light during standby.	Recycle
Yellow	Control is in Pump Prime mode OR reset button is currently held for >15 seconds.	Cad cell resistance.

OPERATION AND TROUBLESHOOTING

Beckett NX BURNER TROUBLESHOOTING

Condition 1: Burner motor does not start when there is a call for heat.

Procedure	Status	Corrective Action
1. Check that limit switches are closed and contacts are clean.	N/A	N/A
2. Check for line voltage power at the oil primary control. Voltage should be 120 Vac between the black and white lead wires on the oil primary control.	N/A	N/A
3. Check indicator light with burner off, no call for heat (no flame).	Green Indicator light is on.	Cad cell is defective, sees external light, or connections have shorted. Go to step 4.
	Green Indicator light is off.	Go to step 6.
4. Shield cad cell from external light.	Green Indicator light turns off.	Eliminate external light source or permanently shield cad cell.
	Green Indicator light stays on.	Replace cad cell with new cad cell and recheck. If indicator light does not turn off, remove cad cell lead wires from Aquastat and recheck. If indicator light is still on, replace the Aquastat control. If the indicator light turns off, replace cad cell bracket assembly.
5. Verify that the oil valve is closed during the "valve on delay" period by observing the view port and verifying that no flame is present during the 15-second "valve on delay".	Green Indicator light is on.	If flame is present, replace the oil valve.
6. Jumper thermostat (T-T) terminals on Aquastat IMPORTANT First remove one thermostat lead wire.	Burner starts.	Trouble is in thermostat circuit. Check thermostat-wiring connections. If connections are clean and tight, check thermostat wires for continuity.
	Burner does not start.	<ul style="list-style-type: none"> • Disconnect line voltage power and open line switch. • Check all wiring connections. • Tighten any loose connections and recheck. • If burner still doesn't start, replace Aquastat. <p>If burner still doesn't start, check the oil burner motor. It may be seized or burned out.</p>

OPERATION AND TROUBLESHOOTING

Condition 2: Burner starts then locks out on safety with red indicator light flashing.		
Procedure	Status	Corrective Action
1. Reset oil primary control by pushing in and releasing red reset button.	Indicator light stops flashing.	Go to Step 2.
	Indicator light continues to flash at 1/2 second on, 1/2 second off rate.	Verify that the control is not in restricted mode. (See notes at end of this table.). If not in restricted mode, replace Aquastat
2. Listen for spark after burner turns on (after 2 second delay).	Ignition is off	Spark igniter could be defective. Check for line voltage at igniter terminals. If line voltage is present, replace R7484.
	Ignition is on.	Go to Step 3.
	Ignition is on but no oil is being sprayed into the combustion chamber.	Wait for "Valve ON" delay to complete. Check oil supply. Ensure BVS bypass contact close and bypass pressure switch for 10-seconds. After 10-seconds, check pressure switch on BVS to ensure closed. Pressure switch open. Check pressure tubes for proper connection or possible obstructions. Check venting for blockage. Check combustion air intake for blockage. Check pressure switch operation. Check oil line valve. Check for filter blockage or seized oil pump.
3. Check indicator light after flame is established, but before oil primary control locks out.	Indicator light is on until the control locks out and starts flashing during lockout.	Check Aquastat
	Indicator light stays off.	Go to step 4.
4. Check cad cell sighting for view of flame. • Disconnect line voltage power and open line switch. • Unplug cad cell and clean cad cell face with soft clothe. Check sighting for clear view of flame. Replace cad cell in socket. • Reconnect line voltage power and close line switch. • Start burner.	Burner locks out.	Go to step 5.
	Burner keeps running.	System is OK.
5. Check cad cell. • Disconnect line voltage power and open line switch. • Remove existing cad cell and replace with new cad cell. • Disconnect all wires from thermostat terminals to ensure that there is no call for heat. • Reconnect line voltage power and close line switch. • Expose new cad cell to bright light such as a flashlight.	Indicator light is on.	Remount control onto burner housing. Go to step 6.
	Indicator light is off.	Go to step 6.
6. Check cad cell bracket assembly. • Disconnect line voltage power and open line switch. • Remove cad cell wires from quick connect connectors on the Aquastat and leave control lead wires open. • Apply power to device. • Place jumper across cad cell terminals after burner motor turns on.	Indicator light is on.	Replace cad cell bracket assembly.
	Indicator light is off.	Replace Aquastat.
NOTE: Restricted Mode - (Limited Reset): In order to limit the accumulation of unburned oil in the combustion chamber, the control can be reset only 3 times, after which, the control locks out. The reset count returns to zero each time a call for heat is successfully completed. To reset from Restricted Mode: press and hold the reset button for 30 seconds. When the LED flashes twice, the device has reset.		
NOTE: Disable function: Pressing and holding the reset button will disable all functions until the button is released. The burner will restart at the beginning of the normal heat cycle on safety check.		

OPERATION AND TROUBLESHOOTING

Beckett NX: System and General Troubleshooting		
Problem	Possible Cause	Remedy
Boiler will not start.	Thermostat not calling for heat.	<ul style="list-style-type: none"> Check thermostat and adjust. Also, check thermostat for accuracy; if it is a mercury switch type, it might be off level.
	No power to Boiler.	<ul style="list-style-type: none"> Check Boiler switch, main electrical panel Boiler fuse or circuit breaker. Also look for any other hand operated switch, such as an old poorly located Boiler switch, which was not removed during Boiler replacement.
	Thermostat faulty.	<ul style="list-style-type: none"> Remove thermostat wires from control terminals T-T. Place a jumper across T-T. If Boiler starts, replace thermostat, thermostat sub-base (if equipped), or both.
	Oil primary control faulty.	<ul style="list-style-type: none"> Check reset button on oil primary control.
	Photo Cell wiring shorted or room light leaking into photo cell compartment	<ul style="list-style-type: none"> Check photocell (cad cell) wiring for short circuits. Also, check for room light leaking into cad cell compartment. Repair light leak if necessary. See Table C-3.
	Open safety switch.	<ul style="list-style-type: none"> Check for open limit or auxiliary limit. Also, check internal wiring connections; loose connectors, etc.
Boiler will not start without first pushing oil primary control reset button. (Happens on frequent basis)	Photo Cell (Cad Cell) defective.	<ul style="list-style-type: none"> If cad cell is dirty, clean it. (Determine why cad cell is getting dirty). If cad cell is poorly aimed, realign it. NOTE: The photocell should have a resistance of 100KΩ in absence of light; a maximum of 1500Ω in the presence of light. Ensure that room light is not leaking into the cad cell compartment. (See diagnostic light section).
	No fuel oil.	<ul style="list-style-type: none"> Check fuel oil supply. Check that all hand operated fuel oil valves are in the open position. Fill oil storage tank if necessary.
	Clogged nozzle.	<ul style="list-style-type: none"> Replace nozzle with high quality replacement. Use rating plate or Tables in Appendix A as a guide.
	Clogged oil filter.	<ul style="list-style-type: none"> Replace oil tank filter or in-line filter if used.
	Blocked Vent Safety Circuit opening.	<ul style="list-style-type: none"> Pressure switch open: Check pressure tubes for proper connection or possible obstructions. Check venting for blockage. Check combustion air intake for blockage. Check pressure switch operation.
	Low oil pump pressure.	<ul style="list-style-type: none"> Connect pressure gauge to oil pump. Adjust pump pressure, or replace oil pump if necessary. Ensure that erratic pressure readings are not caused by defective fuel oil line.
	Air getting into fuel oil lines, or fuel oil line dirty, clogged, or in some manner defective.	<ul style="list-style-type: none"> Check fuel oil lines. Replace any compression fittings found with high quality flared fittings. Check for any signs of oil leaks. Any oil leak is a potential source of air or contaminants.
	Defective burner motor.	<ul style="list-style-type: none"> Check burner motor. If burner motor is cutting out on over-load, determine why. Replace if necessary.
Boiler starts, but cuts out requiring manually resetting the oil protector reset button	No fuel oil.	<ul style="list-style-type: none"> Check fuel oil supply. Check that all hand operated fuel oil valves are in the open position. Fill oil storage tank if necessary.
	Clogged nozzle.	<ul style="list-style-type: none"> Replace nozzle with high quality replacement. Use rating plate or Tables in Appendix A as a guide.
	Clogged oil filter.	<ul style="list-style-type: none"> Replace oil tank filter or in-line filter if used.
	Blocked Vent Safety Circuit opening.	<ul style="list-style-type: none"> Check pressure switch on BVS to ensure closed. Pressure switch open. Check pressure tubes for proper connection or possible obstructions. Check venting for blockage. Check combustion air intake for blockage. Check pressure switch operation.
	Low oil pump pressure.	<ul style="list-style-type: none"> Connect pressure gauge to oil pump. Adjust pump pressure, or replace oil pump if necessary. Ensure that erratic pressure readings are not caused by defective fuel oil line.
	Air getting into fuel oil lines, or fuel oil line dirty, clogged, or in some manner defective.	<ul style="list-style-type: none"> Check fuel oil lines. Replace any compression fittings found with high quality flared fittings. Check for any signs of oil leaks. Any oil leak is a potential source of air or contaminants.
	Defective burner motor.	<ul style="list-style-type: none"> Check burner motor. If burner motor is cutting out on over-load, determine why. Replace if necessary.
	Water or contaminants in oil.	<ul style="list-style-type: none"> Drain fuel oil storage tank, replace fuel oil. (Consult with fuel oil supplier).

OPERATION AND TROUBLESHOOTING

Beckett NX: System and General Troubleshooting		
Problem	Possible Cause	Remedy
Oil burner sputtering at nozzle	Electrodes out of adjustment or defective.	<ul style="list-style-type: none"> Check electrode settings. Check electrodes for dirt build-up or cracks in porcelain.
	Poor transformer high voltage connections or defective transformer.	<ul style="list-style-type: none"> Check contacts between the igniter and electrodes. If OK, replace the igniter
	Fuel oil filter clogged.	<ul style="list-style-type: none"> Replace fuel oil storage tank filter and / or fuel oil in-line filter.
	Defective oil pump.	<ul style="list-style-type: none"> Check burner motor / fuel oil pump coupling. Check oil pump pressure. Replace fuel oil pump if necessary.
	Fuel oil line partially clogged or contains air.	<ul style="list-style-type: none"> Bleed air from oil line. If problem persists, replace oil line.
	Blocked Vent Safety Circuit opening intermittently. (Boiler lights, then turns off)	<ul style="list-style-type: none"> Check pressure switch on BVS to ensure it remains closed. Pressure switch open. Check pressure tubes for proper connection or possible obstructions. Check venting for blockage. Reduce burner head opening. Check combustion air intake for blockage. Check pressure switch operation.
Excessive fuel oil consumption.	Fuel oil leak.	<ul style="list-style-type: none"> Check fuel oil line for leaks. Repair or replace if necessary.
	Thermostat improperly adjusted or in poor location.	<ul style="list-style-type: none"> Check thermostat heat anticipator setting against measured amperage draw. Increase heat anticipator setting if necessary. If the thermostat is being influenced by drafts, sunlight, duct work, etc., relocate to more suitable location.
Too much smoke.	Insufficient combustion air adjustment at oil burner, or improper draft pressure.	<ul style="list-style-type: none"> Check CO₂. Should be 11.5% to 12%
	Heat exchanger partially clogged.	<ul style="list-style-type: none"> Check for soot build-up in heat exchanger flue passages, especially in the outer radiator.
Soot building up on blast tube (end coning).	Flame impingement caused by Incorrect nozzle angle.	<ul style="list-style-type: none"> Check nozzle size and angle. (See Appendix A). Check distance from head to inside surface of the fire pot.
Boiler will not warm home to desired temperature.	Thermostat adjustments or location.	<ul style="list-style-type: none"> Check thermostat heat anticipator setting against measured amperage draw. Increase heat anticipator setting if necessary. If the thermostat is being influenced by drafts, sunlight, duct work, etc., relocate to more suitable location.
	Insufficient water flow.	<ul style="list-style-type: none"> Check all registers.
	Defective high limit control.	<ul style="list-style-type: none"> Test high limit function of all limit switches. Use a duct thermometer to assess accuracy of limit control. Replace control if necessary.
	Under-sized nozzle.	<ul style="list-style-type: none"> Check nozzle and nozzle filter for dirt.
Home does not heat evenly	Burner motor stopping intermittently on overload.	<ul style="list-style-type: none"> Check burner motor. Pressure switch opening due to blocked vent. Replace if necessary.
	Improper distribution of heat.	<ul style="list-style-type: none"> This is not likely to be a Boiler problem. Balance duct system.

OPERATION AND TROUBLESHOOTING

Riello 40BF blocked vent safety (BVS) Operation	
External Action	Appliance Response
Thermostat calls for heat.	<ul style="list-style-type: none"> • Burner enters pre-purge. • After pre-purge, oil valve is energized and burner lights off. • Burner operates in run mode. • Normally closed pressure switch monitors for vent or combustion air intake blockage.
Call for heat is satisfied.	<ul style="list-style-type: none"> • Oil valve circuit is de-energized and valve shuts off. • Burner motor runs for duration of burner motor-off delay. • Burner motor turns off.
Pressure switch contacts open and cause burner to re-cycle.	<ol style="list-style-type: none"> 1. Check for vent blockage. 2. Check for combustion air intake blockage. 3. Ensure pressure tubes are connected properly and clear of obstructions. 4. Check burner set up.

RIELLO 40BF BURNER TROUBLESHOOTING		
Condition: Thermostat is calling for heat. Burner is not running.		
Problem	Possible Cause	Remedy
Reset control box.	Burner starts.	Go to step #3
	Burner does not start	Go to step #1
1. Test for 120 Vac supply at sub-base between L (P) & N or terminals #3 and #5.	120 Vac present.	Go to step #2
	No voltage	<ul style="list-style-type: none"> • Check system fuse, breaker or ensure service switch is ON. • Verify all limits are closed. • If using switching relay, verify 24 Vac at T-T. • Verify BVS pressure switch is closed.
2. Turn off power supply- Remove control box and jumper terminals #5 and #6. Restore power.	Motor runs.	<ul style="list-style-type: none"> • Verify reduced voltage (42-52 Vac) between terminals #3 and #7. • Ensure good contact between control box spades and sub-base terminals. • Defective control box/ Replace.
	Motor does not run.	<ul style="list-style-type: none"> • Verify electrical connections. • Check for seized pump, motor, or fan against housing. • Defective motor capacitor. • Thermal overload (Hot motor).
3. Burner Starts	Burner stays in Pre-purge.	<ul style="list-style-type: none"> • Faulty CAD cell or seeing light before trial for ignition. • Coil wires on terminals #1 and #2 or #1 and #8 reversed. • Open coil circuit; terminals #2 and #8. • Open coil circuit; terminal #1 • Defective 42-52 Vac supply, terminals #3 and #7. • Defective control box/ Replace
	Burner continues to purge and light off with immediate flame dropout.	<ul style="list-style-type: none"> • Metal yoke for coil missing. • Coil wire #2 and #8 reversed. • Low resistance of coil holding circuit, terminals #1 and #2, (1350 ohms \pm 10%). • Verify BVS pressure switch is remaining closed upon light off.
	Burner locks out after trial for ignition.	<ul style="list-style-type: none"> • Low resistance or no contact on starting circuit of coil, terminals #2 and #8. (1.3-ohm \pm %) • No oil supply- tank empty, valve closed, dirty filter, damaged supply lines. • Defective or dirty oil valve stem, nozzle, or pump strainer. • Broken pump drive key, defective pump or no oil pressure. • Ignition electrodes shorted, cracked porcelain. • Burner motor not up to speed. • Excessive draft over fire. • Defective control box/ Replace.
4. Burner Runs, post purge successful. Aquastat Shows Error EE4.	Some Aquastats limit post purge time to 1 minute. Error unique to early models of L7248.	<ul style="list-style-type: none"> • Reset Post purge timer on Fan Timer Board to 45 seconds.

OPERATION AND TROUBLESHOOTING

RIELLO 40BF Blocked Vent safety system (BVS) TROUBLESHOOTING		
Condition: Thermostat is calling for heat. Burner is not running.		
Problem	Possible Cause	Remedy
Test BVS pressure switch contacts are closed.	Contacts closed.	Go to step #2.
	Contacts open	Verify pressure tubing is connected properly and clear of obstructions. Verify vent is not obstructed. Verify combustion air intake is not obstructed. Replace.
Turn off power supply- Remove control box and jumper terminals #5 and #6. Restore power.	Motor runs.	Verify reduced voltage (42-52 Vac) between terminals #3 and #7. Ensure good contact between control box spades and sub-base terminals. Defective control box/ Replace.
	Motor does not run.	Verify electrical connections. Check for seized pump, motor, or fan against housing. Defective motor capacitor. Thermal overload (Hot motor).
Burner Starts	Burner stays in Pre-purge.	Faulty CAD cell or seeing light before trial for ignition. Coil wires on terminals #1 and #2 or #1 and #8 reversed. Open coil circuit; terminals #2 and #8. Open coil circuit; terminal #1 Defective 42-52 Vac supply, terminals #3 and #7. Defective control box/ Replace
	Burner continues to purge and light off with immediate flame dropout.	Metal yoke for coil missing. Coil wire #2 and #8 reversed. Low resistance of coil holding circuit, terminals #1 and #2, (1350 ohms \pm 10%). Verify BVS pressure switch is remaining closed upon light off.
	Burner locks out after trial for ignition.	Low resistance or no contact on starting circuit of coil, terminals #2 and #8. (1.3-ohm \pm %) No oil supply- tank empty, valve closed, dirty filter, damaged supply lines. Defective or dirty oil valve stem, nozzle, or pump strainer. Broken pump drive key, defective pump or oil pressure. Ignition electrodes shorted, cracked porcelain. Burner motor not up to speed. Excessive draft over fire. Defective control box/ Replace.

HOMEOWNER'S REFERENCE TABLE

Model No.

Serial No.

Date Installed

Contractor

Contact

Address

Postal Code

Telephone No.

After Hours No.
