



MODEL NUMBERS:

ESC3100, ESC4100,
ESC4125, ESC4150,
ESC5175, ESC5200,
ESC6225, ESC7275

ESC STEAM OIL-FIRED CAST IRON BOILER

INSTALLATION, OPERATION & MAINTENANCE MANUAL

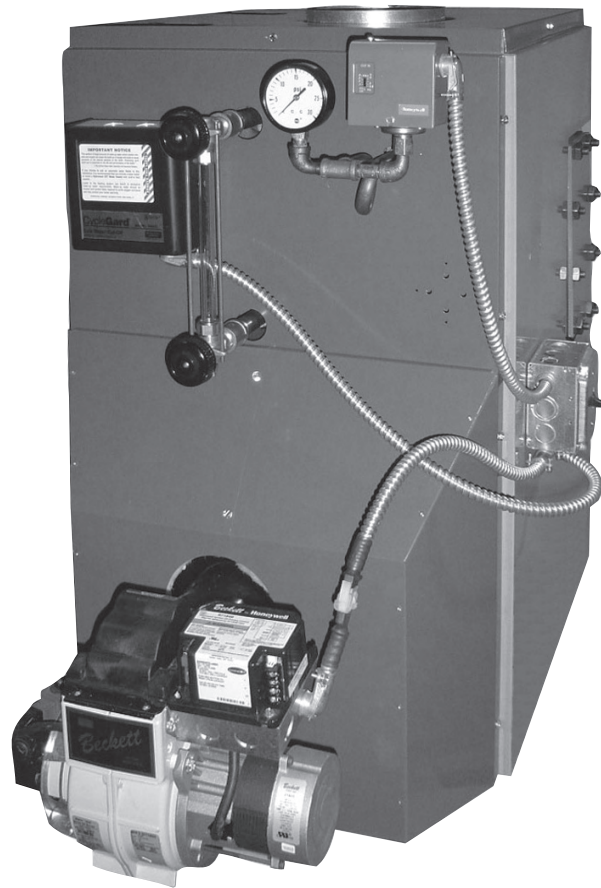

An ISO 9001-2008 Certified Company

DUNKIRK BOILERS

2201 Dwyer Ave.
Utica, NY 13051

www.ecrinternational.com

P/N 240007514, Rev. E [01/2011]

INSTALLATION MANUAL AND OPERATING INSTRUCTIONS

TABLE OF CONTENTS

Ratings, Data, And Dimensions.....	3
Installation Procedure.....	4
Ventilation And Combustion Air	5
Connecting Supply And Return Piping	7
Venting System Inspection & Installation.....	8
Oil Tank And Piping	8
Electrical Wiring.....	9
Thermostat Installation	9
Normal Sequence Of Operation	13
Operating Instructions	13
Maintenance Procedures.....	15
Service Checklist.....	17
Replacement Parts.....	18

**KEEP THIS MANUAL NEAR BOILER
RETAIN FOR FUTURE REFERENCE**

SAFETY SYMBOLS

The following defined symbols are used throughout this manual to notify the reader of potential hazards of varying risk levels.



DANGER

Indicates a hazardous situation which, if not avoided, WILL result in death or serious injury.



WARNING

Indicates a hazardous situation which, if not avoided, could result in death or serious injury.



CAUTION

Indicates a hazardous situation which, if not avoided, may result in minor or moderate injury.

NOTICE

Indicates information which should be followed to ensure proper installation and operation.

IMPORTANT: Read the following instructions COMPLETELY before installing!!

WARNING

1. Keep boiler area clear and free from combustible materials, gasoline and other flammable vapors and liquids.
2. DO NOT obstruct air openings to the boiler room.
3. Modification, substitution or elimination of factory equipped, supplied or specified components may result in property damage, personal injury or the loss of life.
4. TO THE OWNER - Installation and service of this boiler must be performed by a qualified installer.
5. TO THE INSTALLER - Leave all instructions with the boiler for future reference.
6. When this product is installed in the Commonwealth of Massachusetts the installation must be performed by a Licensed Plumber or Licensed Gas Fitter.



WARNING

All installations of boilers and venting should be done only by a qualified expert and in accordance with this manual. Installing or venting a boiler or any other gas appliance with improper methods or materials may result in serious injury or death due to fire or to asphyxiation from poisonous gases such as carbon monoxide which is odorless and invisible.



Tested For 15 psi.
ASME
Working Pressure

RATINGS, DATA, AND DIMENSIONS

Boiler Model Number ⁽¹⁾	I=B=R Oil Burner Input ⁽²⁾		D.O.E. Heating Capacity MBH ⁽⁴⁾	I=B=R Net Ratings ⁽³⁾⁽⁴⁾		Min. Natural Draft Chimney Size		Pump Pressure PSI	Nozzle Furnished 140PSIG ⁽⁵⁾	A.F.U.E. Rating
	G.P.H.	MBH ⁽⁴⁾		Steam MBH	Sq. Ft. Steam	Round	Square			
365S	0.65	91	79	59	246	6	8x8x15	140	.60 80B	85
3100S	1.00	140	116	87	363	6	8x8x15	140	.85 80B	81.5
4100S	1.00	140	120	91	377	7	8x8x15	140	.85 80B	85
4125S	1.25	175	145	109	454	7	8x8x15	140	1.10 60B	82.5
4150S	1.50	210	170	128	533	7	8x8x15	140	1.25 80B	81
5175S	1.75	245	202	152	633	8	8x8x15	140	1.50 80B H	83
5200S	2.00	280	227	170	708	8	8x8x15	140	1.75 70B H	82
6225S	2.25	315	251	188	783	8	8x12x15	140	2.00 45B	-
7275S	2.75	385	307	230	958	8	8x12x15	140	2.25 60B	-

NOTES:

1. Add suffix "T" to denote boiler with tankless heater.
2. I=B=R burner capacity is based on an oil heating value of 140,000 Btu/gal. and with 13% CO₂.
3. Net ratings based on 170°F temperature in radiators and include 33% allowance for normal piping and pick-up load. Consult manufacturer for unusual piping and pick-up temperatures.
4. For altitudes above 2,000 ft. ratings may be reduced at the rate of 4% for every 1,000 ft. above sea level.
5. Nozzle sizes with an H designation are Hago brand, all others are Delavan.
6. The electrical service is 120 Volts, 15 Amps, 60 Hz.
7. The MEA number for this boiler series is 182-86E.
8. The MEA number for the AFG Beckett Burner used in this boiler series are; AF/156-77-E, AFG/213-83-E, AFII 85/24-92-E, AFII 150/ 456-90-E.

TANKLESS WATER HEATER CAPACITIES

Boiler Model Number	Firing Rate G.P.H.	Tankless Heater Number	Tankless Heater Capacity Intermittent Draw G.P.M.	Boiler Water Content (Gallons)	
				To Water Line	To LWCO Line
365S	0.65	L-24	Available on request	11	8
3100S	1.00	L-24	4.5	11	8
4100S	1.00	L-24	4.5	13	9
4125S	1.25	L-24	4.5	13	9
4150S	1.50	L-24	4.5	13	9
5175S	1.75	L-24	5.0	15	10
5200S	2.00	L-24	5.0	15	10
6225S	2.25	L-24	5.0	17	11
7275S	2.75	L-24	5.0	19	12

STANDARD EQUIPMENT: Crated boiler, flush jacket, oil burner, target wall/liner, ASME relief valve, steam water level gauge, steam pressure gauge, steam pressure control, mechanical low water cut-off, drain valve, wiring harness, burner electric disconnect, plastic cover, 2" supply tapping, 1½" return tapping, skim port, and primary control.

(NOTE: For tankless heater units, add tankless hot water coil, and 4006 limit control.)

DIMENSIONS (See Figure A)

Boiler No.	Length of Flush Jacket	Front of Jacket to Center Line of Flue Outlet	Flue Outlet Diameter
	-A-	-B-	-C-
3S	16.375"	6.5"	6.0"
4S	20.25"	8.5"	6.0"
5S	23.875"	10.25"	7.0"
6S	27.5"	8.3125"	8.0"
7S	31.125"	8.3125"	8.0"

Figure #1

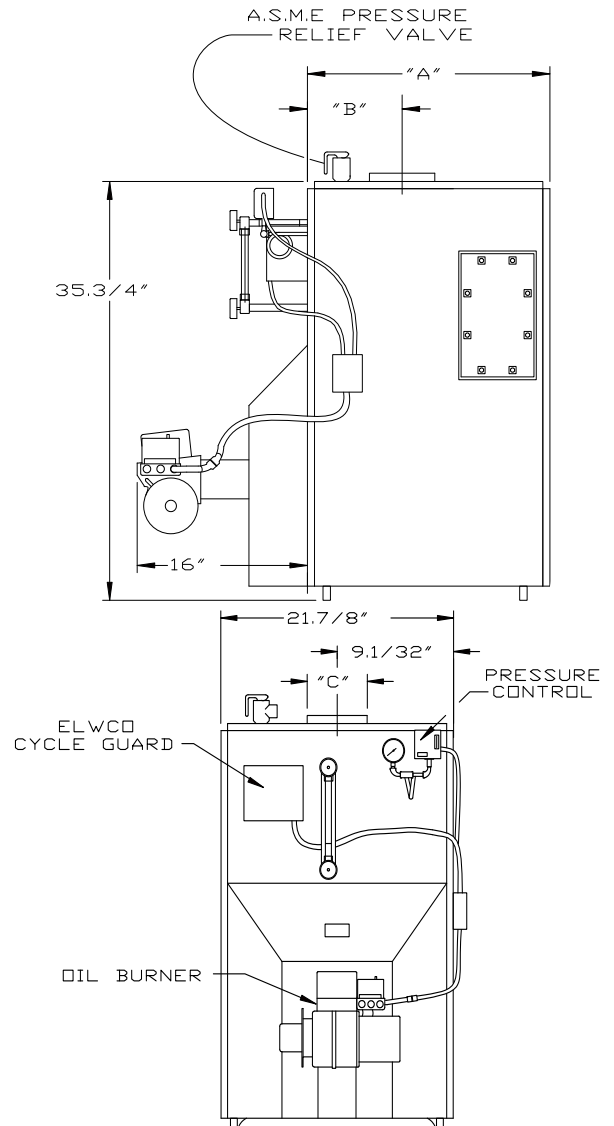

INSTALLATION PROCEDURE



WARNING

Improper installation, adjustment, alteration, service or maintenance can cause injury or property damage.

All installations must conform to the requirements of the authority having jurisdiction. Such applicable requirements take precedence over the general instructions of this manual.

Where required by the authority having jurisdiction, the installation must conform to the American Society of Mechanical Engineers Safety Code for Controls and Safety Devices for Automatically Fired Boilers, ANSI/ASME No. CSD-1.

Locate boiler in front of final position before removing crate. Provide a level solid base as near chimney as possible and centrally located with respect to the heat distribution system as practical.



WARNING

Boiler may not be installed on combustible flooring!!

Allow 24 inches in the front, top and right hand side for servicing and cleaning, or removing tankless water heating coil.

It is recommended that 24 inches be allowed in back of boiler for convenience when skimming hole is used.

When installed in a utility room, the door should be wide enough to allow the largest boiler part to enter, or to permit replacement of another appliance such as a water heater.

The boiler shall be installed such that the oil ignition system components are protected from water (dripping, spraying, rain etc.) during appliance operation and service.

FOR INSTALLATION ON NON-COMBUSTIBLE FLOORS ONLY - The boiler must not be installed on carpeting or vinyl flooring. Minimum clearances to combustible construction are:

TOP	24 IN.
FRONT	24 IN.
FLUE CONNECTOR	9 IN.
REAR	24 IN.
LEFT SIDE	6 IN.
RIGHT SIDE	24IN.

NOTE: Clearance for access should exceed fire protection clearance.

Figure #2

Minimum clearances to combustible construction (as seen from above)

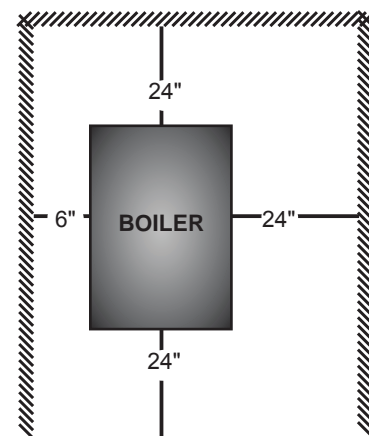

VENTILATION AND COMBUSTION AIR

WARNING



Air openings to combustion area must not be obstructed. By following the instructions below, adequate combustion air can be maintained.

COMBUSTION AIR REQUIREMENTS

(Minimum Opening Requirement)

BTU/Hr Input	Unconfined Area*		Confined Area**	
	Outside	Inside	Outside Combustion Air	
	Combustion Air 1 Sq. In./5000 BTU/Hr (Step 4)	Combustion Air 1 Sq. In./1000 BTU/Hr (Min. 100 Sq. In.) (Figure #1)	Vertical Ducts 1 Sq. In./4000 BTU/Hr (Figures # 2 & #3)	Horizontal Ducts 1 Sq. In./2000 BTU/Hr (Figure # 4)
91,000	19	100	23	46
140,000	28	140	35	70
175,000	35	175	44	88
210,000	42	210	53	106
245,000	49	245	61	122
280,000	56	280	61	140

* A space whose volume is not less than 50 cubic feet per 1000 BTU/Hour of all appliances installed in that space (cubic feet of space = height x width x length)

** A space whose volume is less than 50 cubic feet per 1000 BTU/Hour of all appliances installed in that space (cubic feet of space = height x width x length)

1. Ventilation of boiler room must be adequate enough to provide sufficient air to properly support combustion and venting.
2. When the boiler is located in an unconfined space in a building of conventional construction frame, masonry or metal, infiltration normally is adequate to provide air for combustion and ventilation. However, in any building which has been altered to conserve energy or to minimize infiltration, the boiler area should be considered as a confined space. If there is any doubt, install air supply provisions for combustion and ventilation in accordance with section 5.3, Air for Combustion and Ventilation, of the NFPA 54 1988 code, the recommendations that follow, or applicable provisions of the local building codes.
3. When the boiler is installed in an unconfined space, in a building of unusually tight construction, air for combustion and room ventilation must be obtained from outdoors or from spaces freely communicating with the outdoors. A permanent opening or openings having a total free area of not less than 1 square inch per 5,000 BTU per hour of total input rating of all appliances shall be provided. Ducts may be used to convey make-up air from the outdoors and shall have the same cross-sectional area of the openings to which they are connected.
4. When air for combustion and room ventilation is from inside buildings, the confined space shall be provided

with two permanent openings, one starting 12 inches from the top and one 12 inches from the bottom of the enclosed space. Each opening shall have a minimum free area of 1 square inch per 1,000 BTU per hour of the total input rating of all appliances in the enclosed space, but must not be less than 100 square inches. These openings must freely communicate with the interior areas having adequate infiltration from the outside. **(Figure #3)**

5. When the boiler is installed in a confined space and all air is provided from the outdoors, the confined

Figure #3

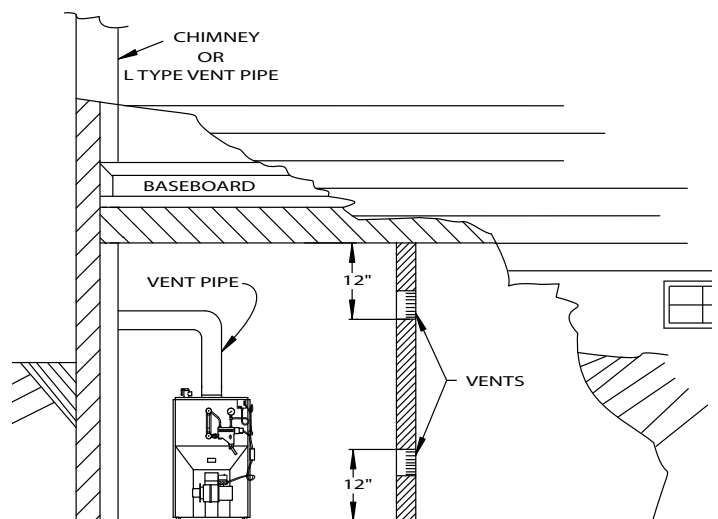

VENTILATION AND COMBUSTION AIR

space shall be provided with two permanent openings, one commencing within 12 inches from the top and one commencing 12 inches from the bottom of the enclosure. The openings shall communicate directly, or by ducts, with the outdoors or spaces (crawl or attic) that freely communicate with the outdoors. One of the following methods must be used to provide adequate air for ventilation and combustion.

- A. When directly communicating with the outdoors, each opening shall have a minimum free area of 1 square inch per 4,000 BTU per hour of total input rating of all equipment in the enclosure. **(Figure #4)**
- B. When communicating with the outdoors by means of vertical ducts, each opening shall have a minimum free area 1 square inch per 4,000 BTU per hour of

Figure #4

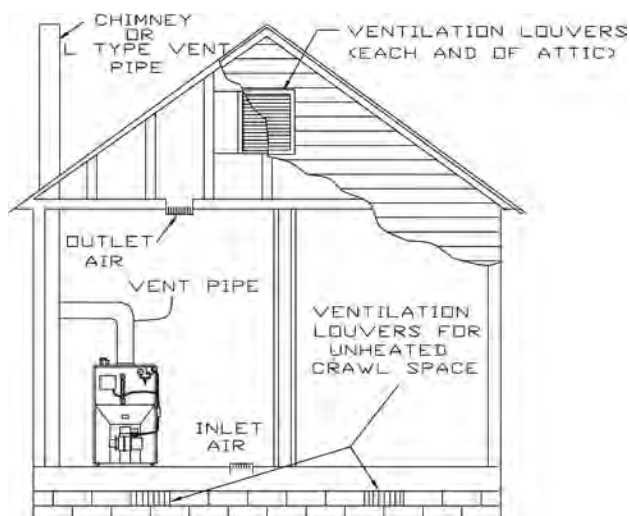

Figure #5

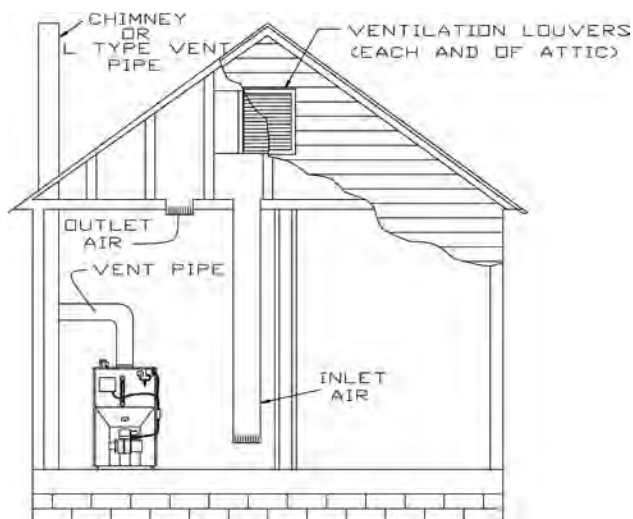
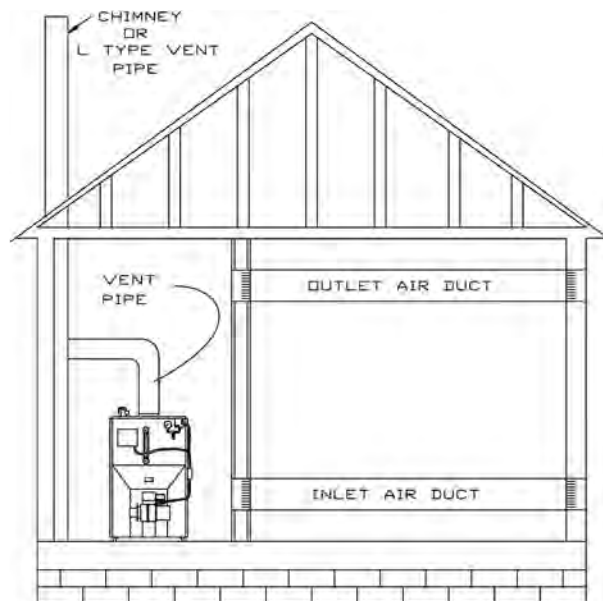

Figure #6



total input rating of all appliances in the enclosed space. **(Figure #5)**

- C. If horizontal ducts are used, each opening shall have a minimum free area 1 square inch per 2,000 BTU per hour total input rating of all appliances in the enclosed space. **(Figure #6)**
- D. When ducts are used, they shall be of the same cross sectional area as the free area of the area of the openings to which they connect. The minimum dimension of rectangular air ducts shall not be less than 3 inches.
6. In calculating free area using louvers, grills or screens for the above, consideration shall be given to their blocking effect. Screens used shall not be smaller than 1/4 inch mesh. If the free area through a design of louver or grill is known, it should be used in calculating the size opening required to provide the free area specified. If the design and free area is not known, it may be assumed that wood louvers will have 20-25% free area and metal louvers and grills will have 60-75% free area. Louvers and grills shall be fixed in the open position or interlocked with the boiler so that they are opened automatically during boiler operation.

CONNECTING SUPPLY AND RETURN PIPING

1. Suggested piping for steam heating system can be seen in **Figure #7**. Actual piping may vary based on system design and local conditions.
2. For further piping information refer to the I=B=R installation piping guide.

3. See **Figure #8** for typical piping for domestic hot water heater.
4. See **Figures #9** and **#10** for the suggested piping for a modular steam boiler.

Figure #7

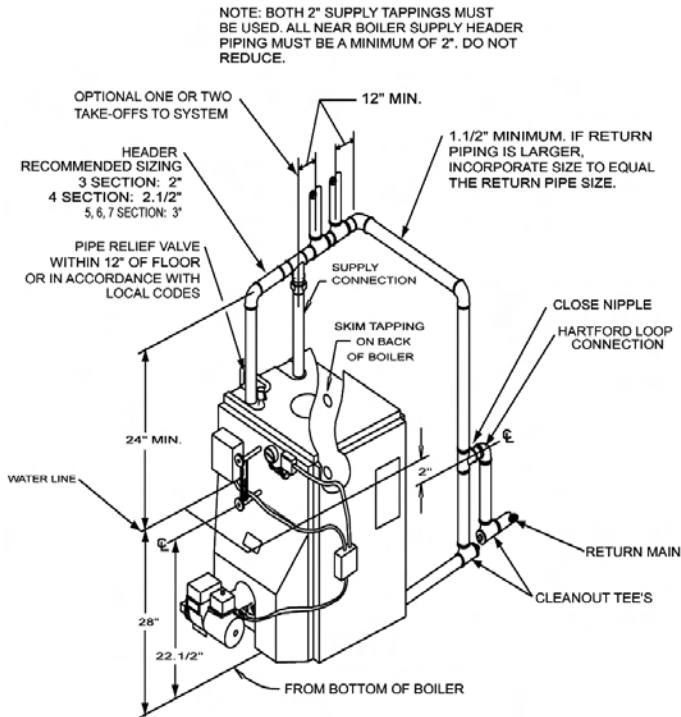

Figure #9

SUGGESTED PIPING FOR MODULAR STEAM BOILERS - PUMPED RETURN

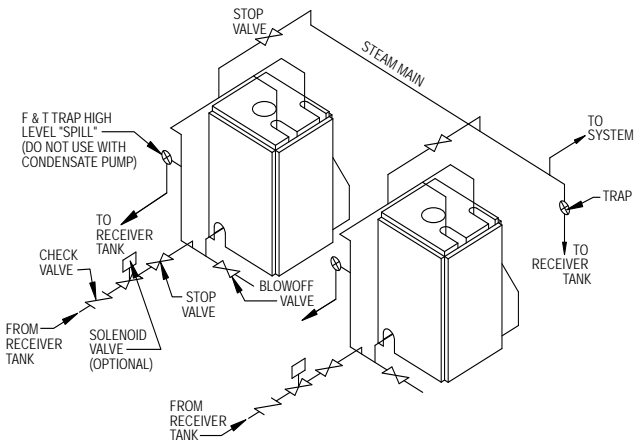

Figure #8

PIPING FOR BUILT-IN DOMESTIC HOT WATER HEATER

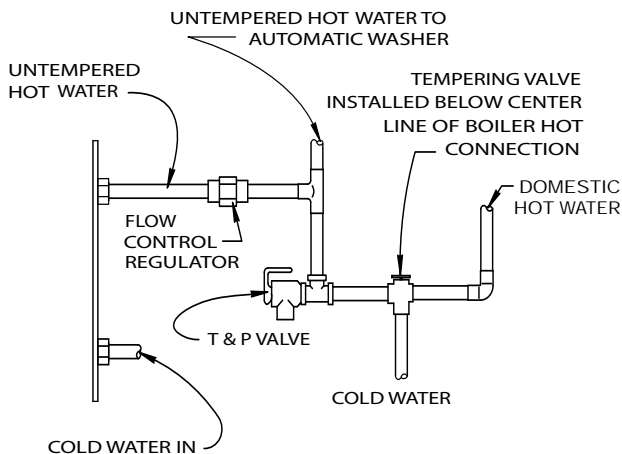
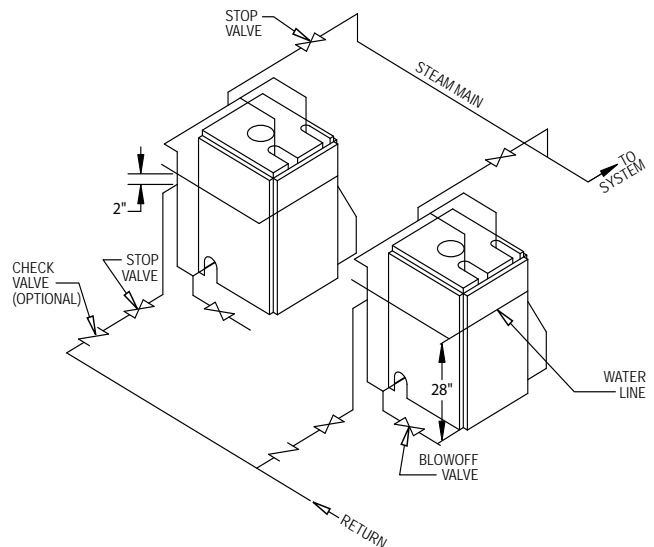

Figure #10

SUGGESTED PIPING FOR MODULAR STEAM BOILERS - GRAVITY RETURN



VENTING SYSTEM INSPECTION & INSTALLATION

WARNING



Boiler is to be vented by natural draft and shall not be connected into any portion of a mechanical draft operating system under a positive pressure.

Inspect chimney to make certain it is constructed according to the latest revision of the NFPA 211. Local regulations may differ from this code and should be checked. Where there is a conflict, the local code will prevail.

The boiler must be installed into a chimney which has a masonry or metallic chimney liner.

An unlined chimney will have leaks that will cause poor chimney performance (no draft), and could result in a positive pressure in the combustion chamber.

Horizontal portions of the venting system should not exceed 10 feet in length. Horizontal lengths over 10 ft. will have a negative effect on the chimney performance.

The chimney should extend at least 2 ft. above any portion of the building within 10 ft. (**Figure #11**) It should produce a -.02 inch W.C. draft in the combustion chamber. See "Chimney or Vent Sizes" chart for recommended minimum and maximum chimney or vent sizes.

Inadequate draft will cause improper combustion, resulting in dirty flue ways and high fuel bills.

Connect flue pipe same size as boiler outlet to chimney, sloping upward continuously toward the chimney approximately 1/4" per foot. Bolt or screw joints together to avoid sag.

If an oil fired water heater is vented into the same flue as the boiler, provide a separate hole into the chimney whenever possible. When this isn't possible, use a "Y" connection in the flue pipe, using a separate draft regulator for each unit. When a chimney will not provide adequate draft to handle the input from the water heater and boiler simultaneously, wire the units so that only one will operate at a time, favoring the water heater.

Figure #11

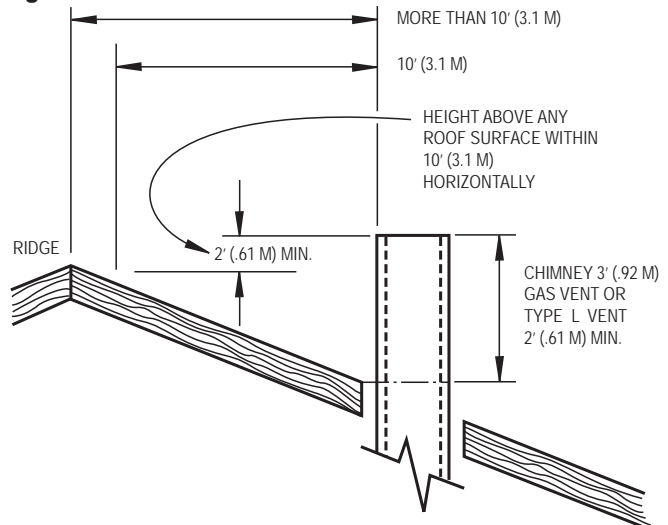

CHIMNEY OR VENT SIZES						
BTU/HR INPUT	ROUND INCHES		SQUARE INCHES		HEIGHT (FT)	
	MIN	MAX	MIN	MAX	MIN	MAX
91,000 - 140,000	6	8	8x8	8x8	15	40
175,000 - 210,000	7	8	8x8	8x10	15	40
245,000 - 280,000	8	10	8x8	8x12	15	50
315,000	8	10	8x8	8x12	15	50
385,000	8	10	8x8	8x12	15	50

OIL TANK AND PIPING

Oil tank and piping should be installed in accordance with the National Board of Fire Underwriters and local regulations. Oil storage tank, vent, fill pipe and caps should be as prescribed by local codes. In no case should the vent pipe be smaller than 1 1/4" I.P.S. The fill pipe should not be less than 2" I.P.S.

The suction line from the tank to the burner should be one continuous piece of tubing to prevent air entering the line. The suction line, must be 3/8" O.D. copper tubing for runs of 50 feet or less, and 1/2" O.D. for longer runs. An oil return line, same size as the suction line, must be used on any installation where the bottom of the tank is below the fuel unit of the burner. Oil lines should be buried or otherwise protected from mechanical injury. Flare fittings on all oil lines are recommended. Compression fittings on the suction line often allow air to be drawn into the fuel pump, making it difficult to maintain oil pressure at the nozzle. Do not run overhead fuel lines from tank to oil burner.

OIL TANK AND PIPING

Fuel pump connections and by-pass should be made according to instructions attached to the fuel pump. If tank is more than 20' from the boiler, a two stage fuel unit should be installed in place of the single stage pump supplied as standard equipment with the burner. Make certain the rotation and speed are the same and the pump is suitable for the burner horsepower rating.

An oil line filter and shut-off valve should be installed in the suction line. Shut-off valves should be installed in both the suction and return lines at the burner for convenience in servicing burner. Allow extra tubing at burner so burner may be removed from boiler for cleaning without disconnecting tubing. (**Figures #12 - #13**) An optional flexible oil line is available.

Figure #12

TYPICAL INSTALLATION SINGLE PIPE OIL SYSTEM

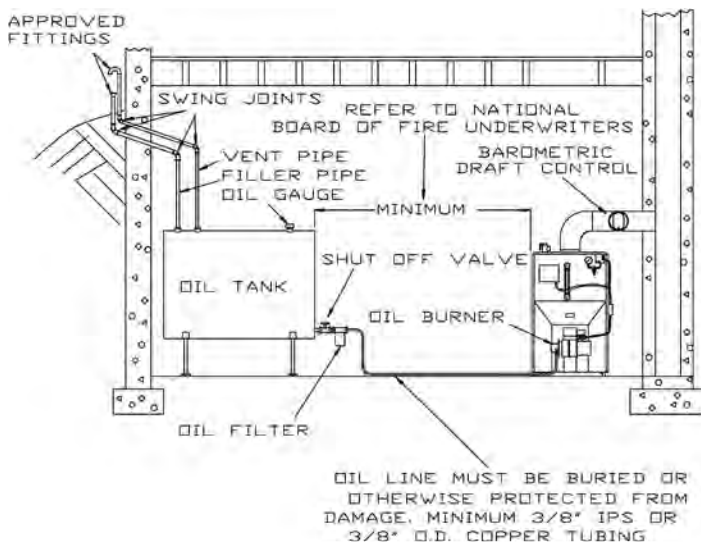
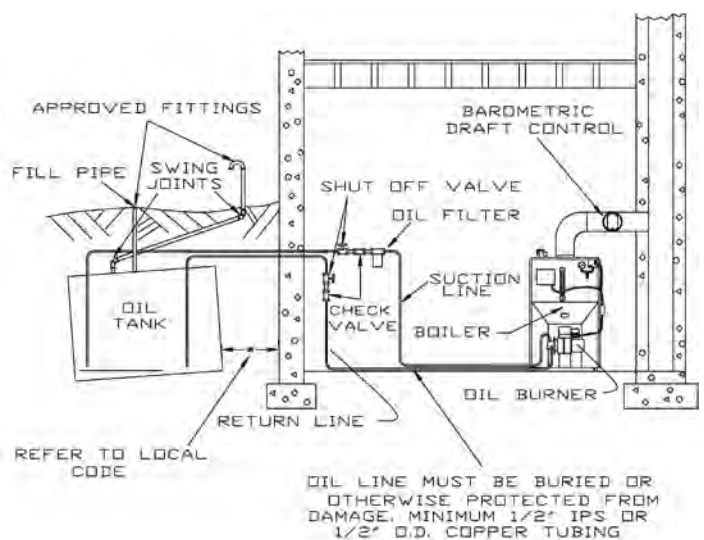

Figure #13

TYPICAL INSTALLATION TWO PIPE OIL SYSTEM



ELECTRICAL WIRING

Electrical wiring must conform with the latest revisions of the National Electrical Code, ANSI/NFPA No. 70, and/or local authority having jurisdiction.

1. When an external electrical source is utilized, the boiler, when installed, **MUST BE** electrically grounded in accordance with these requirements.
2. Install a fused disconnect switch between boiler and meter at a convenient location.
3. When the boiler is equipped with self-energized controls, no outside source of electric power shall be connected to the circuit of this system. (See "Steam Wiring" on next page.)

THERMOSTAT INSTALLATION

1. Thermostat should be installed on an inside wall about four feet above the floor.
2. **NEVER** install a thermostat on an outside wall.
3. Do not install a thermostat where it will be affected by drafts, hot or cold pipes, sunlight, lighting fixtures, television, fireplaces, or chimneys.
4. Check thermostat operation by raising and lowering thermostat as required to start and stop the burner.
5. Instructions for the final adjustment of the thermostat are packaged with the thermostat (adjusting heating anticipator, calibration, etc.).

STEAM WIRING W/BECKETT BURNER

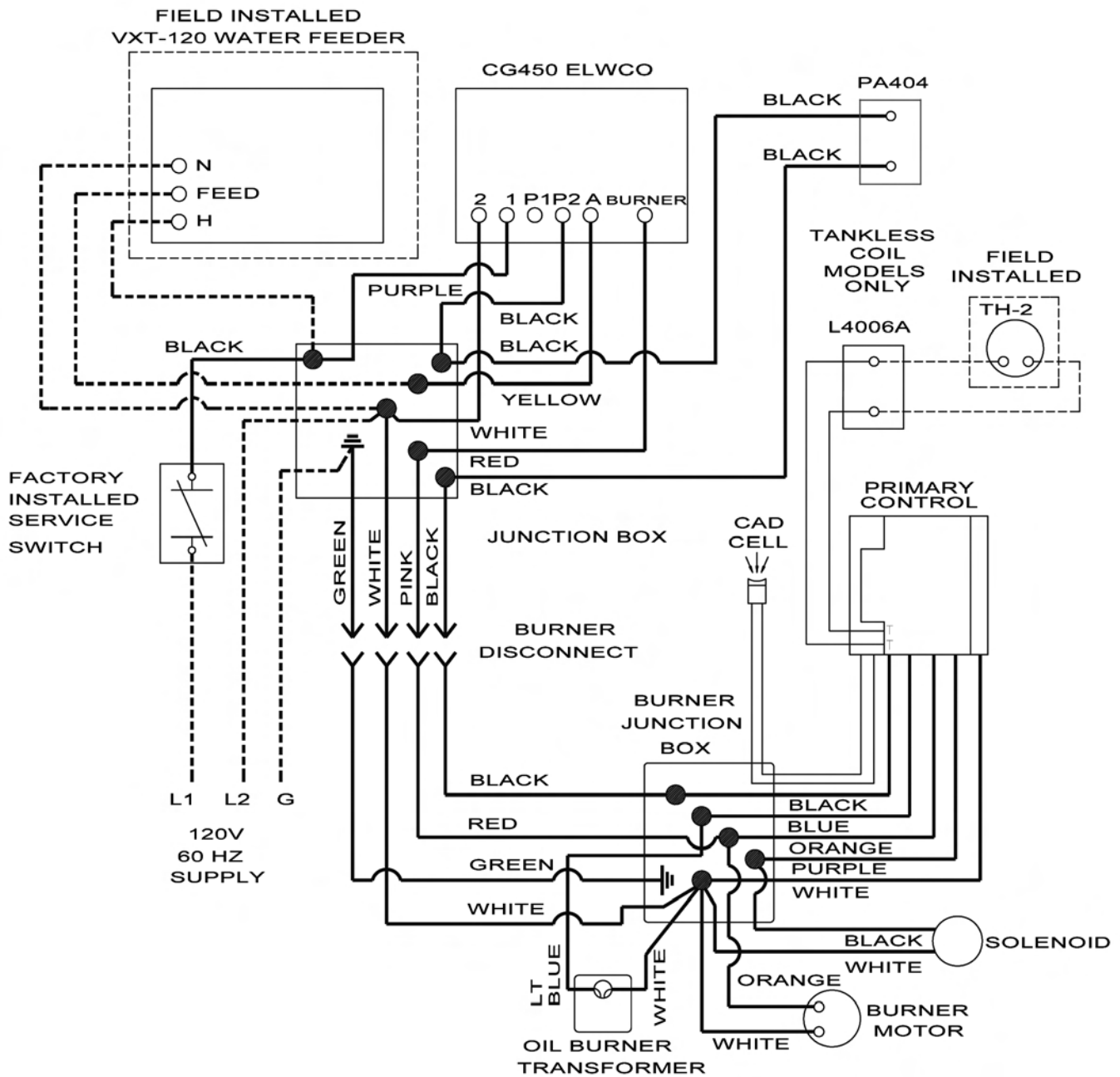

COMPONENT CODING

TH-1	Thermostat (Millivolt)	MR-PS	Manual Reset Pressure Switch	CIR	Circulator
TH-2	Thermostat (24 Volt)	—○—	Control Terminal	ECO	Energy Cut-Off
TH-3	Thermostat (Line Voltage)	1K	Relay Coil	PSC	Pilot Safety Coil
TR-1	Transformer (120V/24V/40VA)	1K1	Relay Contacts	—●—	Wire Connection
TR-2	Transformer (120V/24V/50VA)	1K2	Relay Contacts	LWCO	Low Water Cut Off
LGV24	Volt Gas Valve	LS	Limit Switch	EWF	Electric Water Feeder
PS	Pressure Switch	MS	Manual Switch	PG	Power Generator

WIRING CODE

—————	Line Voltage By Factory
—————	Low Voltage By Factory
— ■ — ■ — ■ — ■ —	Line Voltage By Installer
— - - - -	Low Voltage By Installer

NOTE: Not all components listed are used in all control systems.

STEAM WIRING W/RIELLO BURNER

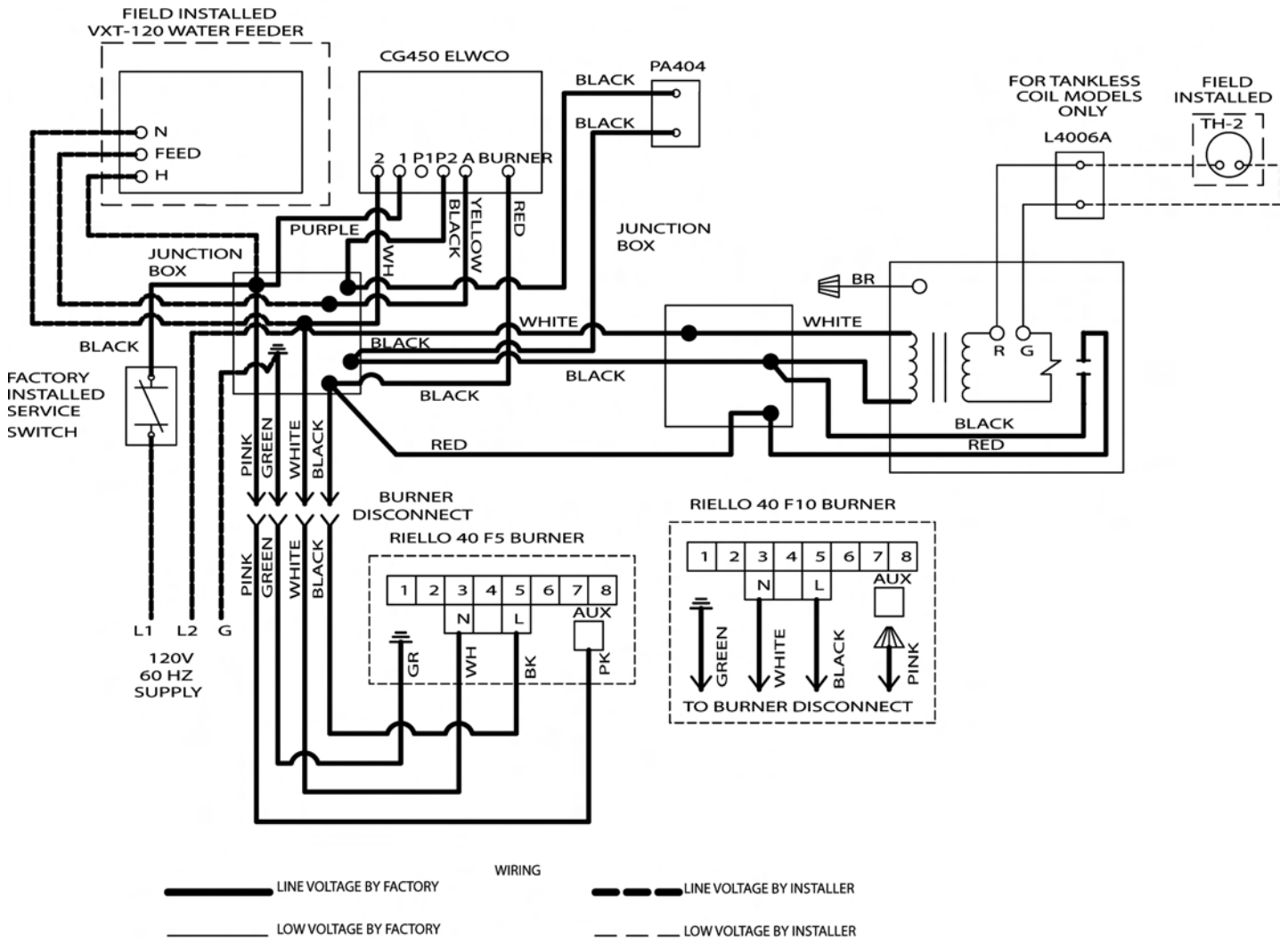

WIRING CODE	
	Line Voltage By Factory
	Low Voltage By Factory
	Line Voltage By Installer
	Low Voltage By Installer

STEAM WIRING W/CARLIN BURNER

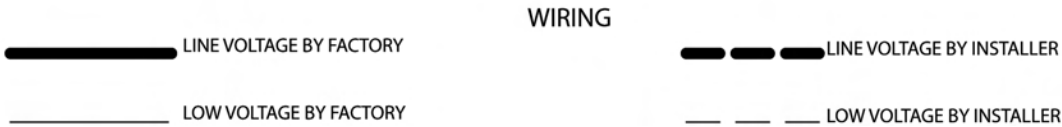
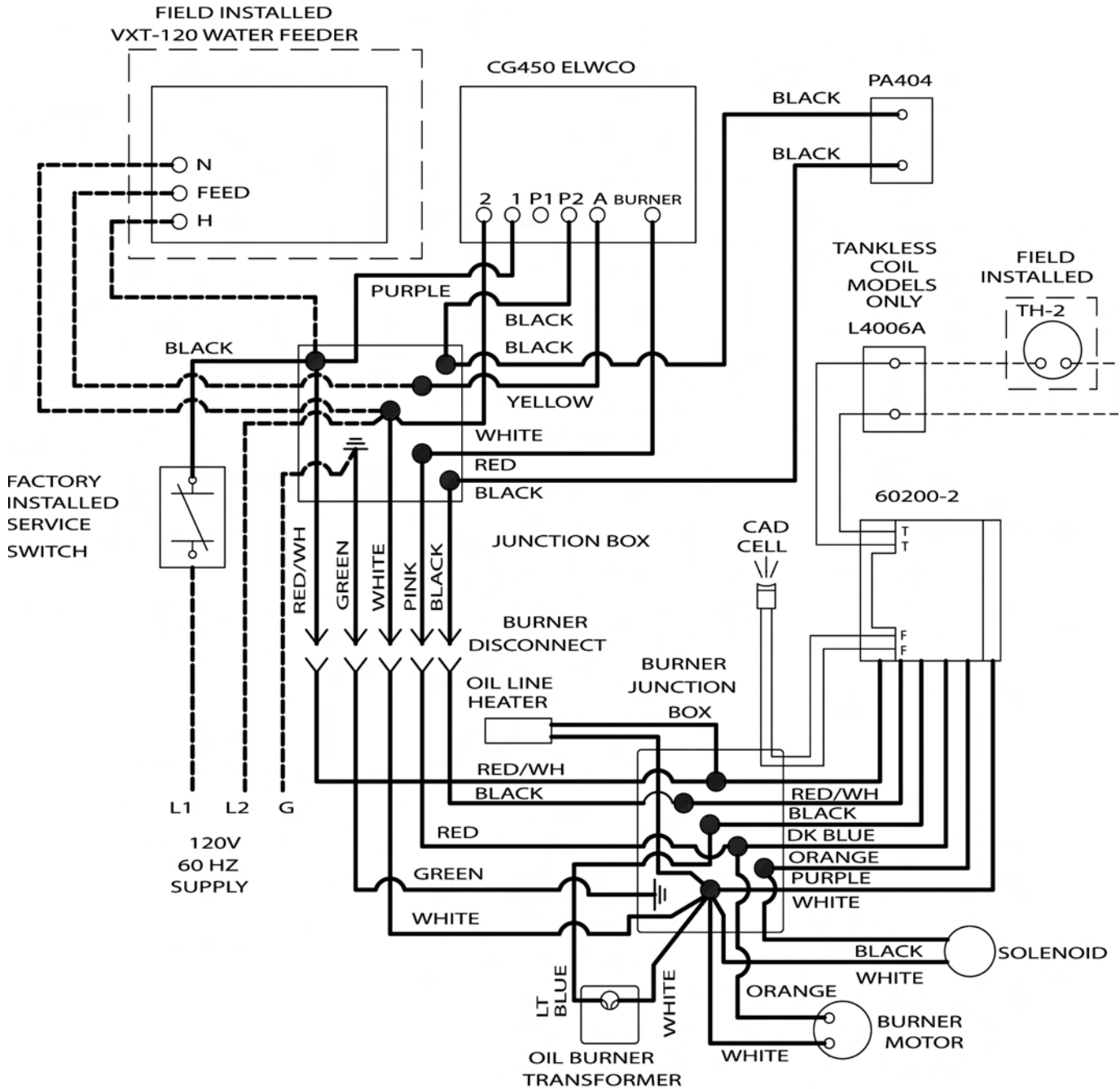

WIRING CODE	
	Line Voltage By Factory
	Low Voltage By Factory
	Line Voltage By Installer
	Low Voltage By Installer

NORMAL SEQUENCE OF OPERATION

On a call for heat, the thermostat will actuate, completing the circuit to the boiler. In turn, the ignition systems are activated and ignition will begin.

In the event of a low water condition, an automatic low water cut-off device will interrupted power between the low water cut-off and the burner. The burner will remain off until the low water condition is corrected, (i.e., manually restore boiler water or utilize a water feeder device which will automatically restore water to its normal operating level).

IMPORTANT TO THE INSTALLER - Before putting the

boiler in operation, test the mechanical low water cut-off device for proper operation. While burner is on, open the blow-off valve located in the lower portion of the cut-off body. This will drain the water quickly from the cut-off body and break the circuit to the burner. If it does not, replace control.



WARNING

WATER WILL BE BOILING HOT.

Refill boiler to its normal water line.

OPERATING INSTRUCTIONS

The venting system should be inspected at the start of each heating season. Check the vent pipe from the boiler to the chimney for signs of deterioration by rust or sagging joints. Repair if necessary.

Remove the vent pipe at the base of the chimney or flue and, using a mirror, check for obstruction and verify compliance to the latest revision of the NFPA 211.

The lever of the pressure relief valve (**Figure #14**) on the boiler should be operated periodically to make sure that it is functioning properly.

The pressure relief valve should open before the steam pressure exceeds the 15 lb. reading on the gauge. If this pressure is exceeded and the pressure relief valve leaks steam when the boiler is operating at normal pressures, it should be immediately replaced. Corrosion can build up rapidly at the valve seat and prevent its functioning as a safety device.

START-UP AND ADJUSTMENT OF OIL BURNER

(See oil burner instructions for nozzle and electrode setting)

Figure #14

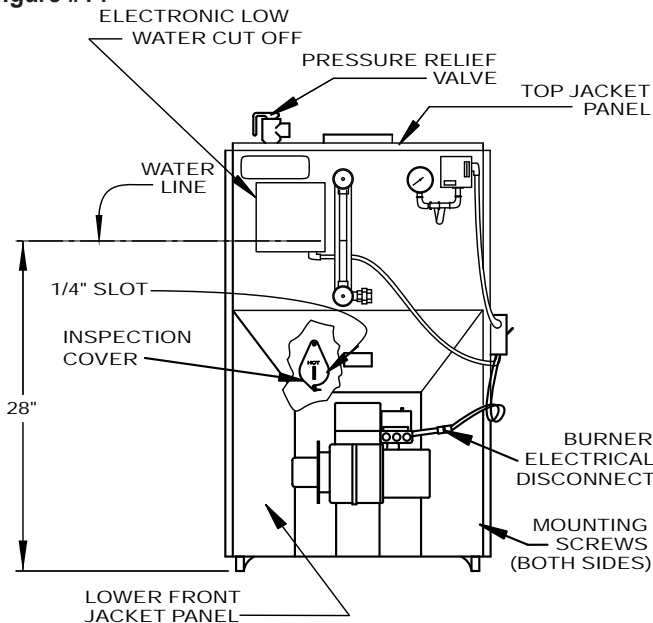

CAUTION

DO NOT SET FIRE VISUALLY.

Instruments are the only reliable method to determine proper air adjustments. An improperly adjusted burner causes soot and high fuel bills because of incomplete combustion of the fuel oil. This in turn may require excessive boiler maintenance, service costs, and in some instances, house cleaning or redecorating. A competent service mechanic should be consulted to make the proper adjustments with a smoke tester, CO₂ indicator, and draft gauge.

NOTE: Bacharach or Dwyer test kits include these instruments.

- Check oil burner nozzle to make certain it is tight in adapter. Burner mounting bolts should be tight.
- Check electrode setting, as they may have been jarred out of position during transportation.
- Lubricate burner motor if necessary.



WARNING

Discharge will be boiling hot water and steam.

OPERATING INSTRUCTIONS

- D. Set room thermostat to call for heat, or jump thermostat contacts on the boiler control.
- E. Open all oil line valves.
- F. Turn service switch on. Burner should start.
- G. On one pipe fuel systems only, bleed pump as soon as burner starts. Allow oil to run until all traces of air in the suction line disappear.
- H. Turn "OFF" burner and install pressure gauge port on pump.
- I. Start burner again and check oil pressure for 140 lbs. Adjust if necessary.

- A. Pressure Control - Remove cover and note pressure setting. With boiler operating, decrease the setting. When the setting is lower than boiler pressure, the control will open and turn off the boiler. After checking pressure control, reset control to original setting.
- B. Mechanical Low Water Cut-off - May be checked by opening the blow-off valve on the lower portion of the cut-off body while the boiler is running. This will drain the water from the boiler and break the circuit to the burner.



WARNING

WATER WILL BE BOILING HOT.

INSTRUCTIONS TO OBTAIN PROPER OPERATION OF

BOILER-BURNER UNIT A ¼" diameter slot is provided in the inspection cover plate to take draft readings in the combustion chamber. **(Figure #14)** A ¼" diameter hole will be required in the flue pipe between the boiler and barometric damper (if used) to take draft, CO₂, smoke and temperature readings. Adjust air shutter on oil burner to obtain a "trace" of smoke. Measure CO₂ at this point. Increase air adjustment to lower CO₂ approximately one percent. Check to insure minimum negative .02 w.c., (water column), "overfire" draft and zero smoke. If -.02 w.c. "overfire" draft can not be maintained, changes and/or modifications may be required in the venting or the chimney.

The following tables are provided as a guideline for initial start-up. Final adjustments **MUST** be made using combustion instruments as previously mentioned.

RIELLO SETTINGS					
Boiler No.	Burner No.	Air Damper	Pump Press.	Turb.	Nozzle Furnished
3100	F-5	3.6	150 PSI	1	.85 80W
4125	F-5	4	150 PSI	3	1.10 60W
4150	F-5	6	150 PSI	4	1.25 60W
5200	F-10	5	150 PSI	0	1.75 80B

CARLIN SETTINGS					
Boiler No.	Burner No.	Air Damper	Pump Press.	Head Bar	Nozzle Furnished
3100	EZ-1	0.85	150 PSI	.85 - 1.00	.85 70B
4125	EZ-1	1.00 - 1.10	150 PSI	1.10 - 1.25	1.10 70B
4150	EZ-1	1.25 - 1.35	150 PSI	1.10 - 1.25	1.25 70B
5200	EZ-2	1.75	150 PSI	1.65 - 1.75	1.75 70B

BECKETT SETTINGS							
Boiler No.	Burner No.	Air Damper	Air Shut.	Pump Press.	Static Disc	End Cone	Nozzle Furnished
3100	AFG	1	5	140 PSI	3 ⅝ U	F3	.85 80B
4125	AFG	1	8	140 PSI	2 ¾"	F4	1.10 60B
4150	AFG	2	6	140 PSI	2 ¾"	F6	1.25 80B
5200	AFG	5	5	140 PSI	3U	F12	1.75 70B H
6225	CF375	4	6	140 PSI	L1	N/A	2.00 45B
7275	CF375	4	6	140 PSI	L1	N/A	2.25 60B

NOTES:

- (1) Model 6225 needs a head setting of 1 and 7275 needs a head setting of 2.
- (2) Nozzle sizes with an H designation are Hago brand, all others are Delavan.
- (3) Information in above table uses Beckett model AFG burner for model numbers 365-5200 and Beckett model CF375 for model numbers 6225 and 7275.

IMPORTANT: Check safety control circuit after burner adjustments have been made for satisfactory performance.

OPERATING INSTRUCTIONS

Refill boiler to its normal water line.

C. Primary Control and Flame Sensor -

To Check:

1. **Flame Failure** - simulate by shutting off oil supply with hand valve while burner is on. Sixty seconds after flame-out, the safety switch locks out, ignition stops, motor stops and oil valve - when used - closes. To restart, open oil supply valve and reset safety switch.
2. **Ignition Failure** - With burner off, close oil supply valve and run through start-up procedure, The safety switch should lock out as in flame failure.
3. **Power Failure** - Turn off main power supply switch while burner is operating. When burner stops, restore power and burner should start. If operation is not as described as above, check wiring and controls.

Preventative maintenance of an oil fired boiler reduces operating costs. The boiler and vent pipe should be inspected for accumulation of soot or scale deposits periodically but at least once every year before the start of each heating season. When soot is present on the section walls and flueways, improper combustion will result, causing additional sooting and scaling until flueways are completely closed. To remove soot and scale from the flueways, remove top jacket panel, top clean-out plate, open burner swing door. (Figure #14)

OPENING THE BURNER SWING DOOR

1. Turn off power to boiler and allow boiler to cool down.
2. Disconnect power cable at factory supplied burner electrical disconnect. (Figure #14)
3. Loosen screws on the sides of the lower front jacket panel. (Figure 6) Pull the bottom part of the lower front panel forward and lift the lower front panel up and off the boiler. (Figure #14)
4. Close oil valve (Figures #12 - #13) and disconnect oil line from burner.

IMPORTANT: Do not open swing door with oil line attached.

5. Remove nut from swing door stud on right hand side of door.
6. Swing open burner and door to the left. Using a flue brush, brush the soot and scale into the combustion space where it can be removed through the swing door opening.

CAUTION



Use caution when vacuuming in the chamber area. Damage to chamber could result.

It is recommended to replace the nozzle at the start of each heating season. Lubricate the burner motor and circulator motor - if required - with a few drops of a good grade of light motor oil. Do not over oil. Have a competent service person service the burner and check the controls and check the electrodes for carbon or cracks in the insulators. Burners should be adjusted to produce the conditions shown in "Startup and Adjustment of Oil Burner."

CLOSING THE BURNER SWING DOOR

1. Swing burner and door to the right until insulation is slightly compressed and the stud is exposed.
2. Attach nut to the stud and tighten it until the built in stop contacts the mounting door.
3. Reconnect oil line to burner.
4. Replace lower jacket panel, and tighten the screws.
5. Connect the power cable at the factory supplied burner electrical disconnect.
6. Turn on power to boiler and bleed oil line.

MAINTENANCE PROCEDURES

Before seasonal start up it is advisable to have a competent service agency check the boiler for soot and scale in the flues, change oil filter and nozzle, clean the burner and readjust burner input rate to maintain proper operation and high operating efficiency.

On steam boilers make certain the boiler is filled to the water line as indicated in Figure #14. The gauge cocks should be normally open. To remove dirt from the gauge glass the petcock may be opened to flush out the glass.



WARNING

Discharge may be boiling hot water.

The radiator valves on a one-pipe steam system must be either wide open or tightly shut. Do not attempt to regulate room temperature by partially closing the radiator valve.

Air vents on steam radiators and the supply main release air from the system. If radiators do not heat satisfactorily, make sure the air vents are clean and operational.

The lever of the pressure relief valve on the boiler (Figure #14) should be operated periodically to make sure that it is functioning properly.

MAINTENANCE PROCEDURES



WARNING

Discharge will be boiling hot water and steam.

The safety valve should open before the steam pressure exceeds the 15 lb. reading on the gauge. (**Figure #14**) If this pressure is exceeded and the safety valve does not open, it must be replaced. If the safety valve leaks steam when the boiler is operating at normal pressures, it should be immediately replaced. Corrosion can build up rapidly at the valve seat and prevent its functioning as a safety device.

If the water in a steam boiler appears to be dirty or oily, or the water level in the gauge glass fluctuates considerably, the boiler should be cleaned. A competent service person will use approved cleaning compounds and properly clean and flush out the boiler. He/she should also clean or replace air vents and traps, clean flue passages and check for proper operation of all controls and safety devices.

The venting system should be inspected at the start of each heating season. Check the vent pipe from the boiler to the chimney for signs of deterioration by rust or sagging joints. Repair if necessary.

Impurities in boiler water of a steam boiler may cause foaming and an unsteady water line, or prevent steam generation. They may result in objectionable odors escaping from the vents on water boilers. This condition is caused by oil, grease, and sediment from pipe fittings collecting within the boiler and can be remedied only by giving the boiler a thorough cleaning.

BOILERS SHOULD BE CLEANED BY SKIMMING OR BLOWING DOWN.



CAUTION

The boiler should not be left unattended during the cleaning process.

SKIMMING OFF IMPURITIES

Some of the impurities in the boiler water will float on the water and must be skimmed off.

With the boiler empty and cool, slowly begin to add water. After water has entered boiler - never before - turn "on" oil burner and adjust water flow so that the water being added is kept just below boiling point. Avoid boiling and turbulence.

Gradually raise hot water level to skimming hole (**Figure #7**) installed on the rear section of the boiler being careful not to raise it above the opening of the hole. Skim until there are no impurities. Repeat the process if necessary.

Water may be checked to make sure it is free from oil by drawing off a sample at the skimming hole. If the sample is reasonably free from oil, it will not froth when boiled on stove. This test does not indicate the amount of sediment which may lay in the bottom of the boiler. It is therefore necessary that the boiler be further cleaned by "blowing down."

BLOWING DOWN THE BOILER

Before blowing down the boiler, fill it to the water line. Turn on burner and allow five pounds of steam pressure to build up. Run a temporary connection from one of the drain valves to a nearby sewer. Connect to a drain valve on the opposite end of the boiler from feed water inlet, if possible. Shut off the oil burner, open drain valve and blow down the entire contents of boiler.

Allow boiler to thoroughly cool and slowly refill to water line. Repeat as many times as required until blow off water is clear. Owner should blow down boiler at least once each month of the heating season.



WARNING

WATER WILL BE BOILING HOT.

USING CLEANING COMPOUND

If an exceptional amount of dirt or sludge seems to be present in the boiler, a boiler cleaning compound made by a reputable manufacturer may be used according to the instructions of the manufacturer of the compound. When any type of cleaning compound is used, care must be taken to thoroughly flush all traces of the compound out of the boiler.

Following blow down allow the boiler to cool. Add fresh water slowly. Be certain to blow enough times as required to remove compounds from system.

The area around the boiler must be kept clear and free of combustible materials, gasoline and other flammable vapors and liquids.

The free flow of combustion and ventilation air to the boiler and boiler room must not be restricted or blocked.

MAINTENANCE PROCEDURES

Periodic inspection and tightening of the tankless heater/cover plate bolts will reduce the risk of leaks. See parts 3 and 5 under "Coil and Cover Plate Replacement Parts."

ELECTRONIC LOW WATER CUT-OFF

Operation of the probe and control should be checked, with the burner on, by draining the water via the drain on the bottom of the boiler. This will drain the water quickly from the boiler and break the circuit to the burner. If it does not inspect the probe for scaling. If scaling is present, clean off the probe, refill the boiler until the ELWCO is satisfied, and perform the check again.



WARNING

WATER WILL BE BOILING HOT.

It is suggested that a qualified service agency be employed to make an annual inspection of the boiler and heating system. They are experienced in making the inspections outlined above and, in the event repairs or corrections are necessary, can make the proper changes for safe operation of the boiler.

SERVICE CHECKLIST

Inspect Chimney and Flue Pipe	[X]	Controls and Safety Devices	[X]
Inspect and Clean Appliance	[X]	Nozzle-Size, Angle, Type	[*]
Inspect Oil Line - Size/Leaks	[X]	Pump Pressure/Vacuum	[*]
Inspect Electrical Connections	[X]	Line Voltage/Motor Amps	[*]
Install New Filter	[X]	Smoke Test	[*]
Room Make-up Air	[X]	Draft-Overfire/In Flue	[*]
Electrode Setting	[X]	CO ₂ or O ₂	[*]
Proper Light-Off (Hot & Cold)	[X]	Flue Gas Temperature	[*]

* Measure with instruments and record results below.

SERVICE RECORD											
Date	Nozzle			Pump Pressure PSI	Line Voltage	Motor Amps	Smoke#	Draft		CO ₂ or O ₂	Flue Temp °F
	Size	Angle	Type					O.F.	INF		

REPLACEMENT PARTS

COIL AND COVER PLATE

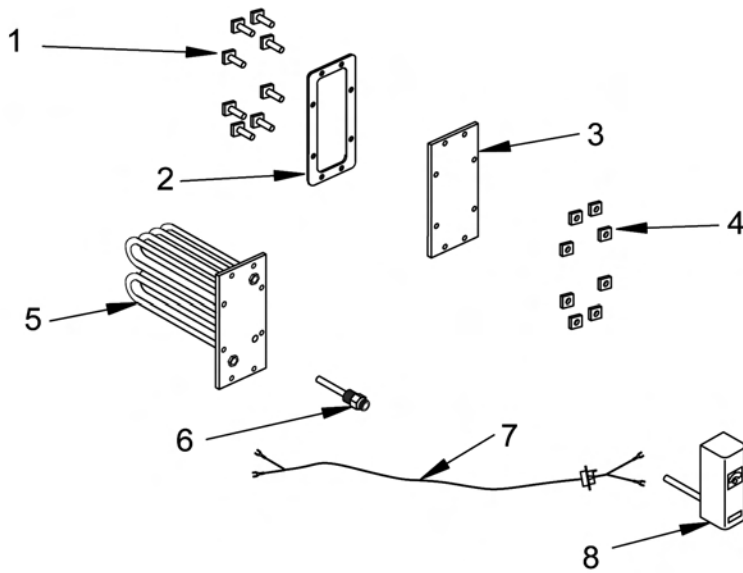

ITEM	PART NO.	DESCRIPTION	QTY.
1	HW-012.02	Bolt - 7/16-14 x 1 1/2 Square Head	8
2	252-2-2.00	Gasket - B Tankless	1
3	202-2-1.00	Cover Plate - B Tankless Coil	1
4	HW-013.01	Nut 7/16 - 14 Square	8
5	252-3-1.02	Tankless Coil L - 24	1
6	1635001	Well 3/4 x 1 1/2 - 123870A	1
7	275-1-1.00	Harness	1
8	AQ-008.00	Control - L4006A1827	1

CONTROLS AND HARDWARE

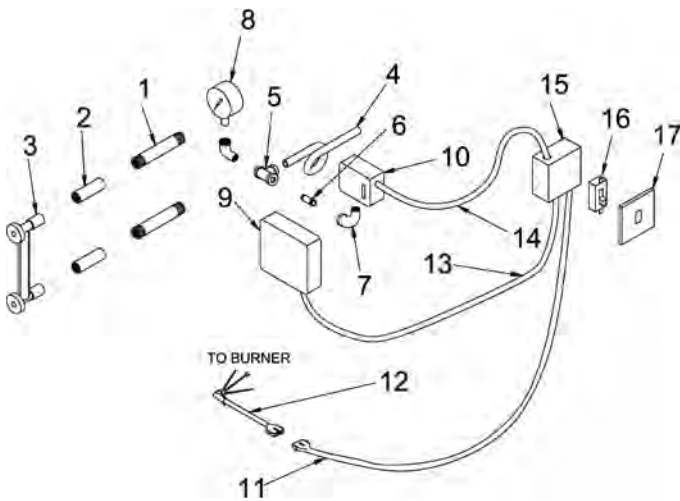

ITEM	PART NO.	DESCRIPTION	QTY
1	PF-033.02	NPL, 1/2x4NPT, BRS	2
2	14693052	CPLG, BRS, 1/2	2
3	GA-004.00	GAUGE WATER LEVEL	1
4	240007394	BRASS, SIPHON, OFF CENTER, LOOP, 62208	1
5	14693057	TEE BRASS 1/4"	1
6	240007412	PIPE, BRASS, 1/4"x3"	1
7	240007411	ELB, BRASS, 1/4", 90, STREET	2
8	GA-003.00	GAUGE PRESSURE (STEAM)	1
9	240007160	ELWCO, CG450-P-2060, CYCLE GUARD	1
10	SS-001.01	PRESSURE SWITCH PA404A-1009	1
11	1263012	HARN, J-BOX, 22" (BECKETT & RIELLO)	1
	240007185	HARN, J-BOX, STEAM, CARLIN	
12	240007187	HARN, BRNR, STEAM, BECKETT	1
	1263011	BURNER HARNESS 8" RIELLO	
	240007186	HARN, BRNR, STEAM, CARLIN	
13	240007161	HARN, ELWCO	1
14	28511201	HARNESS PRESSURE SWITCH 30"	1
15	14631316	BOX, ELEC, 4"x2.1/8", CSA	1
16	240007282	SW, TOGGLE	1
17	240007281	J BOX, TOGGLE, COVER, 4"x4"	1

* This includes MLWCO #2, 4, 5, 7, 8, 9, & 10

REPLACEMENT PARTS

HARDWARE

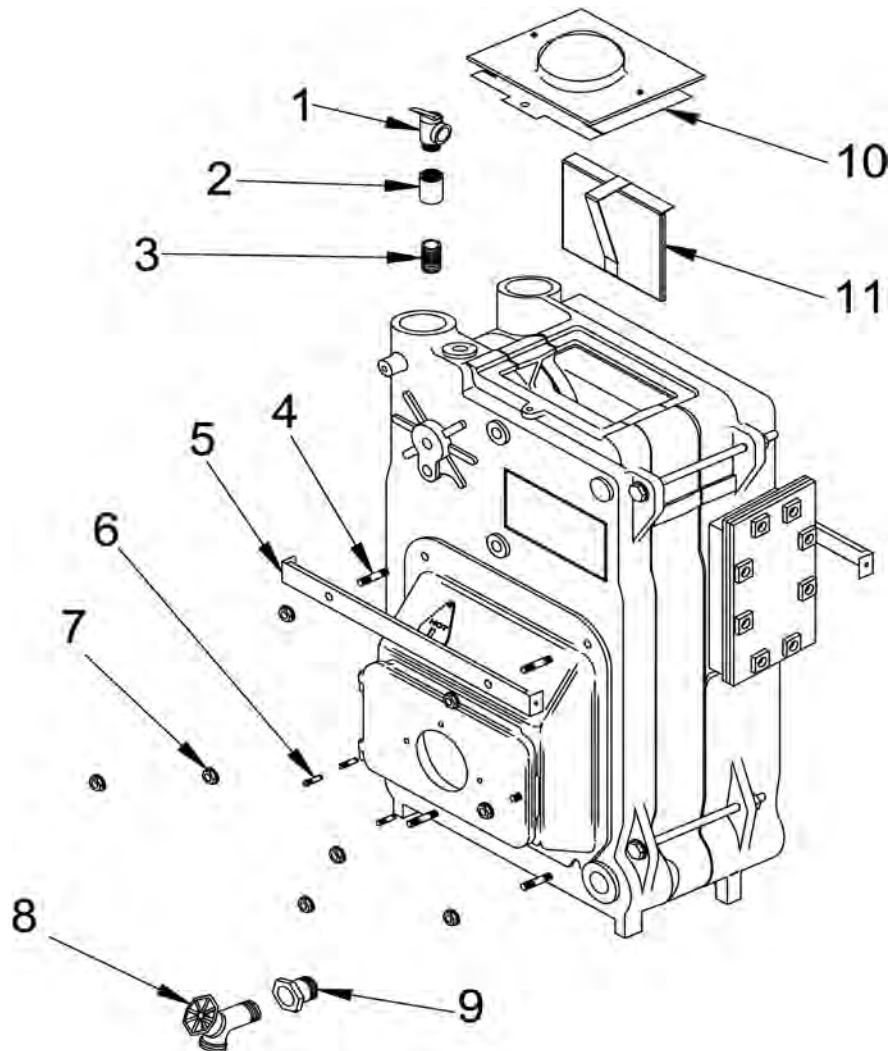

ITEM	PART NO.	DESCRIPTION	QTY
1	1570001	Relief Valve #15 3/4	1
2	PF-019.02	Pipe Fit Coupling 3/4"	1
3	PF-005.01	Pipe Fit Npl 3/4 Close	1
4	HW06701	Stud 5/16"-18 x 2 3/8	4
5	2252501	Support - Jacket Brkt	2
6	HW07001	Stud 5/16" x 18 x 1 3/8"	3
7	HW06901	Nut 5/16" - 18 Wislock	8
8	HW-016.02	Drain	1
9	PF-004.04	Pipe Fit Bushing 1 1/4 x 3/4	1
10	2452906	Flue Collector - 3 Sec.	1
	2452902	Flue Collector - 4 Sec.	
	2452903	Flue Collector - 5 Sec.	
	2452907	Flue Collector - 6 Sec.	
	2452908	Flue Collector - 7 Sec.	
11	109007327	Baffle, Assy, H/E, Rear	1

REPLACEMENT PARTS

HEAT EXCHANGER

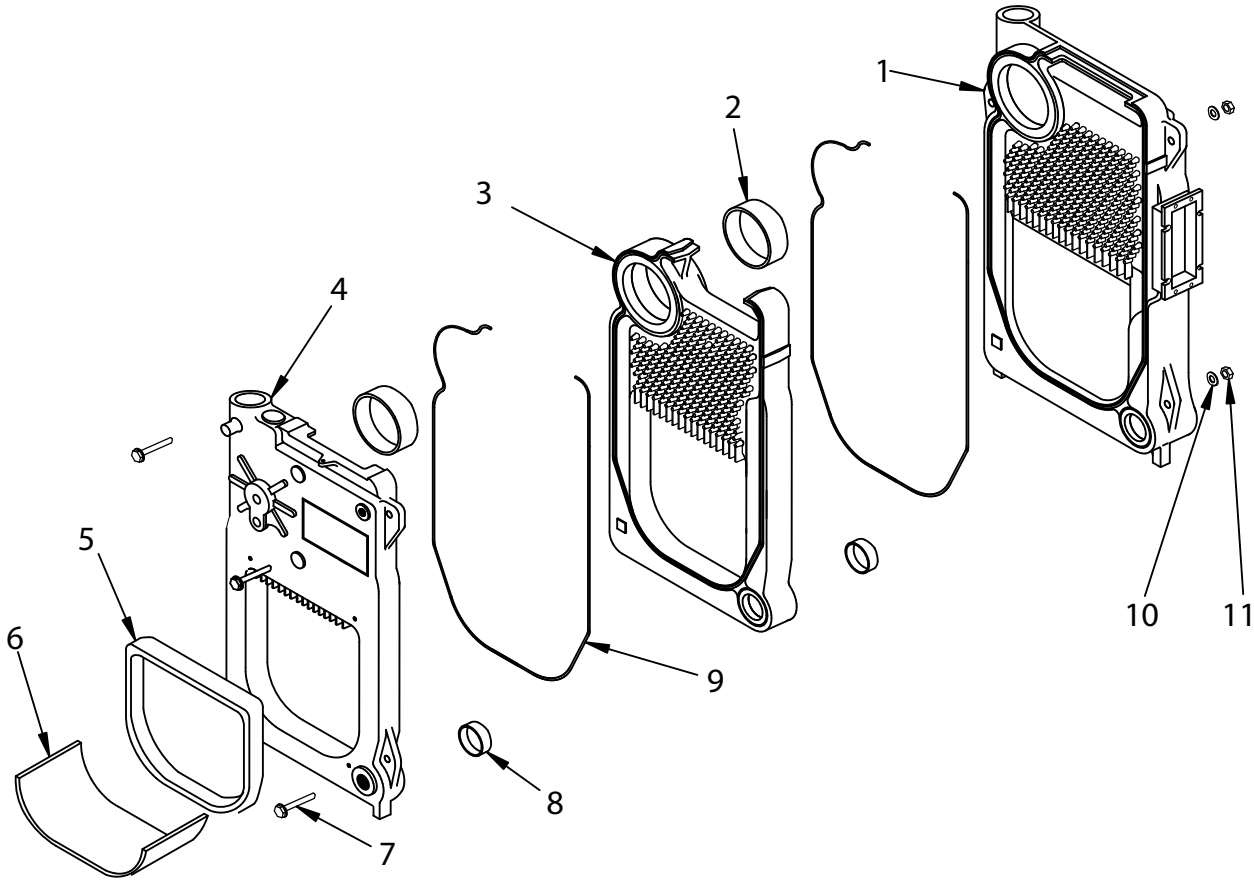

ITEM	PART NO.	DESCRIPTION	QTY
1	100-5-10.01	Rear Section	1
2	100-1-8.01	#60 Push Nipple - 3 Sec.	2
		#60 Push Nipple - 4 Sec.	3
		#60 Push Nipple - 5 Sec.	4
		#60 Push Nipple - 6 Sec.	5
		#60 Push Nipple - 7 Sec.	6
3	10051101	Center Section - 3 Sec.	1
		Center Section - 4 Sec.	2
		Center Section - 5 Sec.	3
		Center Section - 6 Sec.	4
		Center Section - 7 Sec.	5
4	10051802	Front Section Castover	1
5611508		Kit - Target Wall & Insulation Blanket	
Kit Includes #5 and #6			
5	2552701	Target Wall - Pyrolite	1
6	25511005	Insul Blanket 16x24	1
7	HW-025.05	Tie Rod ½ x 9 - 3 Sec.	3
	HW-025.01	Tie Rod ½ x 12½ - 4 Sec.	
	HW-025.02	Tie Rod ½ x 16½ - 5 Sec.	
	HW-025.03	Tie Rod ½ x 20½ - 6 Sec.	
	HW-025.09	Tie Rod ½ x 23½ - 7 Sec.	

ITEM	PART NO.	DESCRIPTION	QTY
8	100-1-5.01	#22 Push Nipple - 3 Sec.	2
		#22 Push Nipple - 4 Sec.	3
		#22 Push Nipple - 5 Sec.	4
		#22 Push Nipple - 6 Sec.	5
		#22 Push Nipple - 7 Sec.	6
9	MS-006.00	Rope, Med. Density - 3 Sec.	13.0'
		Rope, Med. Density - 4 Sec.	19.5'
		Rope, Med. Density - 5 Sec.	26.0'
		Rope, Med. Density - 6 Sec.	32.5'
		Rope, Med. Density - 7 Sec.	39.0'
10	HW-008.03	Washer ½ ID Flat	3
11	HW-003.05	Nut ½ -13 Hex Head	3

FULLY ASSEMBLED HEAT EXCHANGERS	
550001977	3 Section Without Coil
550001978	4 Section Without Coil
550001979	5 Section Without Coil
550001980	6 Section Without Coil
550001981	7 Section Without Coil
550001982	3 Section With Tankless Coil
550001983	4 Section With Tankless Coil
550001984	5 Section With Tankless Coil
550001985	6 Section With Tankless Coil
550001986	7 Section With Tankless Coil

REPLACEMENT PARTS

SWING DOOR AND MOUNTING DOOR COMPONENTS

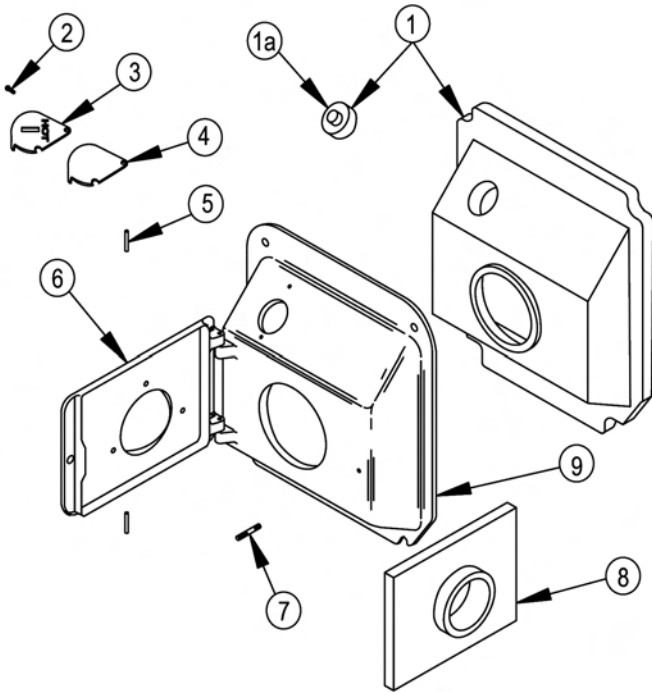

ITEM	PART NO.	DESCRIPTION	QTY
1	2552901	Mounting Door Insulation & Plug	1
1a	2551901	Door Plug Replacement	1
2	HW-005.01	Screw ¼ - 20 x ½ Self-Tapping	2
3	10011701	Observation Door	1
4	25511101	Obs. Door Gasket	1
5	HW06801	¼ x 1¼ Drive Lock Pin	2
6	10011501	Swing Door	1
7	HW06701	5/16 x 18 x 2 3/8 Stud	1
8	2553301	Insulation - Swing Door (Carlin & Riello Burners)	1
	2553303	Insulation - Swing Door (Beckett AFG Burners)	
9	10011301	Mounting Door	1
Not Shown	10011601	Cast Iron Mtg/Swing Dr Mach. Includes Item 2,3,4,5,6,7 & 9	1

JACKETS

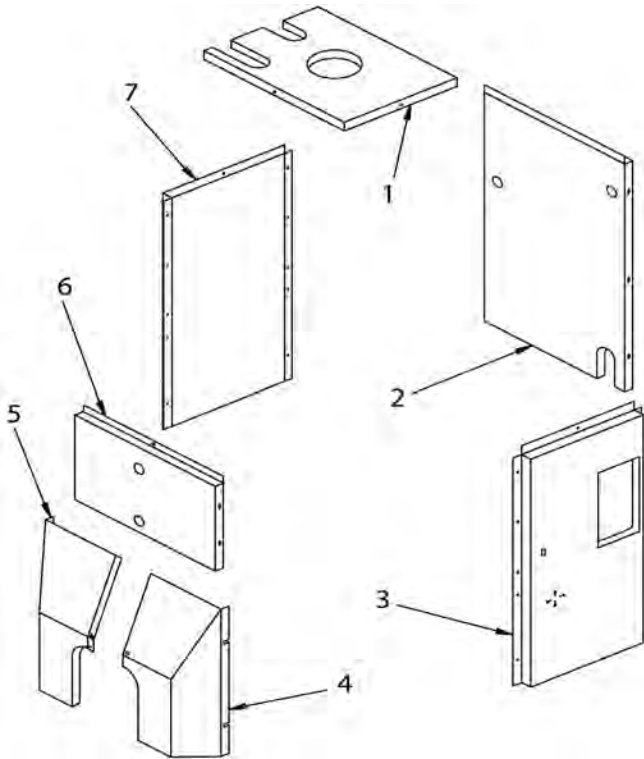

* Items 4 and 5 must be ordered to receive full jacket set

ITEM	DESCRIPTION	MODEL			
		SFE	CSFE	ESC	KSC
		PART #			
1	Top Panel - 3 Sec.	21522801	21522801	21522801	21522808
	Top Panel - 4 Sec.	21522802	21522802	21522802	21522809
	Top Panel - 5 Sec.	21522803	21522803	21522803	21522810
	Top Panel - 6 Sec.	21522806	21522806	21522806	21522811
	Top Panel - 7 Sec.	21522807	21522807	21522807	21522812
2	Rear Panel	21521501	21521501	21521501	21521502
3	Right Side Panel - 3 Sec.	21523101	21523101	21523106	21523101
	Right Side Panel - 4 Sec.	21523102	21523102	21523107	21523102
	Right Side Panel - 5 Sec.	21523103	21523103	21523108	21523103
	Right Side Panel - 6 Sec.	21523104	21523104	21523109	21523104
	Right Side Panel - 7 Sec.	21523105	21523105	21523110	21523105
4	Lower Cowl - Right	21524401	21524401C	21524401	21524402
5	Lower Cowl - Left	21524301	21524301C	21524301	21524302
6	Top Front Panel	21524101	21524101	21524101	21524102
7	Left Side Panel - 3 Sec.	21521803	21521803	21521808	21521803
	Left Side Panel - 4 Sec.	21521804	21521804	21521809	21521804
	Left Side Panel - 5 Sec.	21521805	21521805	21521810	21521805
	Left Side Panel - 6 Sec.	21521806	21521806	21521811	21521806
	Left Side Panel - 7 Sec.	21521807	21521807	21521812	21521807
Not Shown	*Jacket Replacement Kit - 3 Sec.	3001487AH	3001487C	3001487AC	3001487AD
	*Jacket Replacement Kit - 4 Sec.	3001488AH	3001488C	3001488AC	3001488AD
	*Jacket Replacement Kit - 5 Sec.	3001489AH	3001489C	3001489AC	3001489AD
	*Jacket Replacement Kit - 6 Sec.	3001490AH	3001490C	3001490AC	3001490AD
	*Jacket Replacement Kit - 7 Sec.	3001491AH	3001491C	3001491AC	3001491AD

REPLACEMENT PARTS
BURNER COMPONENTS

ITEM	PART NO.	DESCRIPTION	QTY
1	240007286	BRNR,BECK,AFG/UT2401,NOZ,.85,80B	1
	240007288	BRNR,BECK,AFG/UT2402,NOZ,1.25,80B	
	240007289	BRNR,BECK,AFG/UT2403,NOZ,1.75,70B	
	240007290	BRNR,BECK,CF375/UT2601,NOZ,2.00,45B	
	240007291	BRNR,BECK,CF375/UT2602,NOZ,2.25,60B	
	1050006	BRNR,F5/40 SERIES,RIELLO,2 PCS	
	BN07007	BRNR,F10/40 SER,RIELLO #3949071	
	NEW	BRNR,OIL,EZ1,3100SE/STE,CARLIN	
	NEW	BRNR,OIL,EZ1,4100SE/STE,CARLIN	
	NEW	BRNR,OIL,EZ1,4125SE/STE,CARLIN	
	NEW	BRNR,OIL,EZ1,4150SE/STE,CARLIN	
	NEW	BRNR,OIL,EZ1,5200SE/STE,CARLIN	
2	BN08001	BURNER OIL FLANGE GASKET #3616	1
3	CD-001.01	CAD CELL (FOR BOILERS W/ BECKETT BURNERS ONLY)	1
4	240008816	CONTROL R7184B 1032 (7456U) (FOR BOILERS W/ BECKETT BURNERS ONLY)	1
5	1320003	NOZZLE .60 80B (365 BECKETT)	1
	1320004	NOZZLE .85 80B (3100 & 4100 BECKETT)	
	NZ-002.08	NOZZLE 1.10 80B (4125 BECKETT)	
	NZ-002.10	NOZZLE 1.25 80B (4150 BECKETT)	
	NZ00206	NOZZLE 1.75 80B (5200 BECKETT)	
	NZ01201	NOZZLE 2.00 45B (6225 BECKETT)	
	NZ00701	NOZZLE 2.25 60B (7275 BECKETT)	
	NZ00802	NOZZLE .85 80W (3100 & 4100 RIELLO)	
	1320012	NOZZLE 1.10 60W (4125 RIELLO)	
	1320013	NOZZLE 1.25 60W (4150 RIELLO)	
	NZ00206	NOZZLE 1.75 80B (5200 RIELLO)	
	NZ00902	NOZZLE .85 70B (3100 & 4100 CARLIN)	
	1320010	NOZZLE 1.10 70B (4125 CARLIN)	
	NZ00904	NOZZLE 1.25 70B (4150 CARLIN)	
	NZ00905	NOZZLE 1.75 70B (5200 CARLIN)	

BURNER COMPONENTS (BECKETT BURNERS ONLY)

AFG BURNER PARTS (Used on all boiler models with Beckett Burners except 6225 and 7275)		
ITEM	PART NO.	DESCRIPTION
1	RP03801	Blast Tube AFG
2	1402006	Fuel Pump, 2 Stage, 140 PSI, AFG
	RP03702	Fuel Pump, 1 Stage, 140 PSI, AFG
3	BN07102	Drawer Assembly (Oil Line), AFG
4	1250002	Burner Gasket
5	1050008	Motor
6	1050007	Transformer

BECKETT CF375 BURNER PARTS (Used on models 6225 and 7275)		
ITEM	PART NO.	DESCRIPTION
1	1402019	Fuel Pump, Cleancut (21844U)
2	1050008	Motor, PSC (21805U)
3	1050007	Transformer (51771U)
4	RP04601	Oil Burner Valve Coil Kit (21755U)

