

INSTALLATION AND OPERATING INSTRUCTIONS FOR CSD-1 COMMERCIAL BOILER CONTROLS

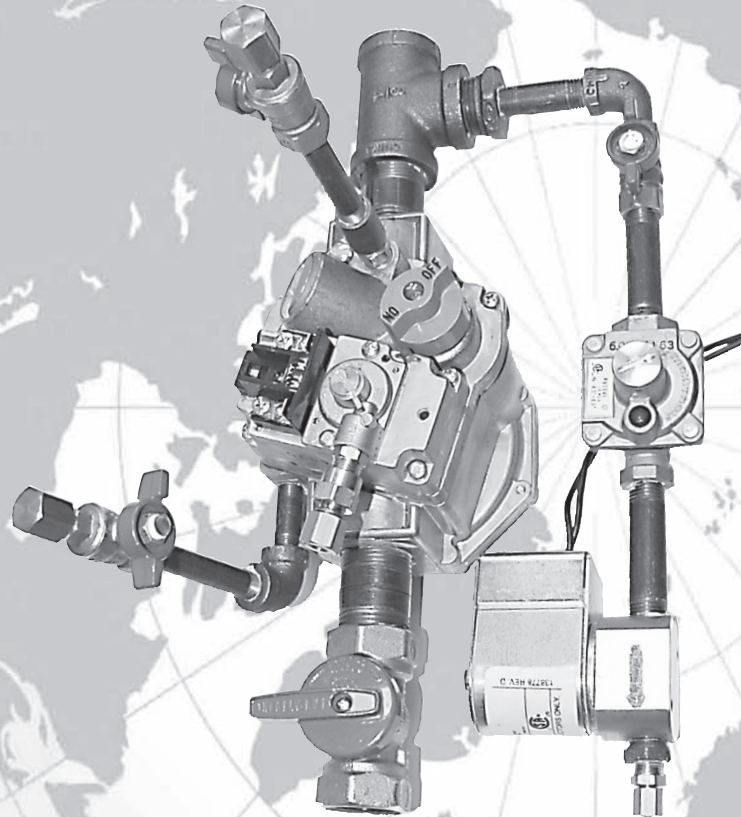

CSD-1 COMMERCIAL BOILER CONTROLS



Your commercial boiler is furnished with combustion side water or steam controls to meet our interpretation of the American Society of Mechanical Engineers (ASME) Safety Code for Controls and Safety Devices for Automatically Fired Boilers, No. CSD-1.

The installation must conform to the requirements of the authority having jurisdiction, or, in the absence of such requirements, to the National Fuel Gas Code, ANSI-Z223.1/NFPA-54 (latest revision). Where required by the authority having jurisdiction, the installation must conform to the American Society of Mechanical Engineers (ASME) Safety Code for Controls and Safety Devices for Automatically Fire Boilers, No. CSD-1.

The CSD-1 controls and this installation may be subject to approval by local inspectors. Additional parts or equipment may be required. Consult local authorities having jurisdiction before the installation of the boiler.

The CSD-1 controls furnished with commercial boilers are applicable to boilers with inputs above 400,000 Btu/hr. (Models 500-2500)

In order to make this commercial boiler compliant, some additional parts required by CSD-1 standards are necessary. This supplemental instruction manual should be used in conjunction with the installation instructions for your specific boiler.

INSTALLATION OF CSD-1 COMPONENTS

Based on the parts listed in the installation instructions for your particular boiler, the following changes should be made:

Complete Boiler Material List - The new boiler material list (with notes) for CSD-1 controls is presented in “**Table #1: CSD-1 Complete Boiler Material List.**”

Combustion Side Control - For Models 300 and 400, no changes are required to the existing gas trains. For

Models 500 through 2500, the intermittent pilot control module is required to have a maximum 15 second pilot flame establishing period and the ability to perform a safety shutdown and lockout in the event of a loss of flame signal at the pilot. Here, the intermittent pilot module and a manual reset switch are used to replace the existing pilot module. Further, an independent pilot gas line which includes a manual shutoff valve, a pressure regulator and safety shutoff valve, two leak test cocks on the main gas valve, and a manual shutoff valve located downstream of the main gas valve are added. “**Table #2: CSD-1 Component Carton Material List**” shows the new component carton material list and replaces the corresponding list in the installation manuals. The CSD-1 electric ignition base material list is presented in “**Table #3: CSD-1 Electronic Ignition Base Material List**” and the installed locations of the additional components are shown in Figures 1a and 1b.

For the CSD-1 combustion side control, the light off sequence is as follows:

- Turn on power and set thermostat to call for heat.
- Ignition starts to spark and lights pilot flame.
- Ignition will continue sparking about 12 seconds after pilot lights.
- Main burners ignite.

IMPORTANT: Please be aware the longer pilot flame recognition time is a design feature of the module and nothing is wrong here.

The maximum allowable inlet gas pressure (natural gas only) to the controls in the CSD-1 gas train is 14” w.c. (½ psig). Make sure the inlet gas pressure is at least 5” w.c. but no greater than 14” w.c. If the gas pressure entering the building is greater than 14” w.c., the installing contractor must provide overpressure protection on the downstream piping to prevent buildup of downstream pressures in excess of 14” w.c. in the event that the fuel system pressure regulator fails. Alternatively, the gas pressure entering the building may be reduced with an additional gas pressure regulator outdoors. If the inlet gas pressure to this additional regulator is less than 14” w.c., then overpressure protection may not be required. Consult local jurisdictional authorities before installing the gas supply piping to the boiler.

MATERIAL LISTS

Table #1: CSD-1 Complete Boiler Material List

| Model | Sections | | | CSD-1 Component Carton ^{a & b} | | | Water Trim Carton ^c | Steam Trim Carton ^d | CSD-1 AC Carton | Jacket End Panel Carton | Base End Panel Carton |
|-------|----------|-------|---|---|-----------|-----------|--------------------------------|--------------------------------|-----------------|-------------------------|-----------------------|
| | L | Inner | R | 300 CSD-1 | 400 CSD-1 | 500 CSD-1 | | | | | |
| 300 | 1 | 2 | 1 | | | | WA-1 | SA-1 | 300 | 1 | 1 |
| 400 | 1 | 3 | 1 | | | | WA-1 | SA-1 | 400 | 1 | 1 |
| 500 | 1 | 4 | 1 | | | 1 | WA-1 | SA-1 | 500 | 1 | 1 |
| 600 | 1 | 5 | 1 | 2 | | | WA-1 | SA-2 | 600 | 1 | 1 |
| 700 | 1 | 6 | 1 | 1 | 1 | | WA-2 | SA-2 | 700 | 1 | 1 |
| 800 | 1 | 7 | 1 | | 2 | | WA-2 | SA-3 | 800 | 1 | 1 |
| 900 | 1 | 8 | 1 | | 1 | 1 | WA-2 | SA-3 | 900 | 1 | 1 |
| 1000 | 1 | 9 | 1 | | | 2 | WA-2 | SA-3 | 1000 | 1 | 1 |
| 1100 | 1 | 10 | 1 | 1 | 2 | | WA-2 | SA-3 | 1100 | 1 | 1 |
| 1200 | 1 | 11 | 1 | | 3 | | WA-3 | SA-3 | 1200 | 1 | 1 |
| 1300 | 1 | 12 | 1 | 1 | | 2 | WA-3 | SA-3 | 1300 | 1 | 1 |
| 1400 | 1 | 13 | 1 | | 1 | 2 | WA-3 | SA-3 | 1400 | 1 | 1 |
| 1500 | 1 | 14 | 1 | | 3 | 3 | WA-3 | SA-4 | 1500 | 1 | 1 |
| 1600 | 1 | 15 | 1 | | | | WA-3 | SA-4 | 1600 | 1 | 1 |
| 1700 | 1 | 16 | 1 | 1 | 2 | 2 | WA-4 | SA-4 | 1700 | 1 | 1 |
| 1800 | 1 | 17 | 1 | | 2 | 2 | WA-4 | SA-4 | 1800 | 1 | 1 |
| 1900 | 1 | 18 | 1 | | 3 | 3 | WA-4 | SA-4 | 1900 | 1 | 1 |
| 2000 | 1 | 19 | 1 | | 4 | 4 | WA-4 | SA-4 | 2000 | 1 | 1 |
| 2100 | 1 | 20 | 1 | 2 | 3 | 3 | WA-4 | SA-4 | 2100 | 1 | 1 |
| 2200 | 1 | 21 | 1 | | 2 | 2 | WA-4 | SA-4 | 2200 | 1 | 1 |
| 2300 | 1 | 22 | 1 | | 3 | 3 | WA-4 | SA-4 | 2300 | 1 | 1 |
| 2400 | 1 | 23 | 1 | | 4 | 4 | WA-4 | SA-5 | 2400 | 1 | 1 |
| 2500 | 1 | 24 | 1 | | 5 | 5 | WA-4 | SA-5 | 2500 | 1 | 1 |

- a. For boilers having total inputs of 400 MBH or less and certified by IAS as complying with ANSI Z21.13 (Models 300 and 400), the standard combustion side controls meet CSD-1 and no changes to the standard component carton are required.
- b. There are additional parts on base assemblies for boilers having total inputs from 500 to 2,500 MBH (Models 500 to 2500) to meet CSD-1. See **Table 2: CSD-1 Component Carton Material List** for details.
- c. For hot water boilers, there is an additional CSD-1 water trim carton (Part# 41257102). See **Table 4: CSD-1 Water Trim Carton Material List** for details.
- d. For steam boilers, there is an additional CSD-1 steam trim carton for gravity or condensate pump return (Part# 41257103) or an additional CSD-1 steam trim carton for boiler feed pump return (Part# 41257104). See appropriate CSD-1 Steam Trim Carton Material List (**Tables 5a and 5b**) for details.

Table #2: CSD-1 Component Carton Material List

| Description | Stock No. | Unit | 550001664 | 550001665 | 550001666 |
|--------------------------------------|-----------|------|-----------|-----------|-----------|
| | | | 300 CSD-1 | 400 CSD-1 | 500 CSD-1 |
| 300 Base Assembly CSD-1 | 550001670 | Ea. | 1 | | |
| 400 Base Assembly CSD-1 | 550001671 | Ea. | | 1 | |
| 500 Base Assembly CSD-1 | 550001672 | Ea. | | | 1 |
| 300 Intermediate Jacket Carton | 550001673 | Ea. | 1 | | |
| 400 Intermediate Jacket Carton | 550001674 | Ea. | | 1 | |
| 500 Intermediate Jacket Carton | 550001675 | Ea. | | | 1 |
| 300 Draft Hood | 42557113 | Ea. | 1 | | |
| 400 Draft Hood | 42557114 | Ea. | | 1 | |
| 500 Draft Hood | 42557115 | Ea. | | | 1 |
| Control Panel Assembly | 550001801 | Ea. | | | |
| Control Panel Assembly CSD-1 300/400 | 550001869 | Ea. | 1 | 1 | |
| Control Panel Assembly CSD-1 500 | 550001870 | Ea. | | | 1 |
| Top Front Panel 300 | 109006881 | Ea. | 1 | | |
| Top Front Panel 400 | 109006882 | Ea. | | 1 | |
| Top Front Panel 500 | 109006883 | Ea. | | | 1 |

For boilers having total inputs of 400 MBH or less and certified by IAS as complying with ANSI Z21.13 (Models 300 and 400), the standard combustion side controls meet CSD-1 and no changes to the standard component carton are required.

MATERIAL LISTS

Figure #1a

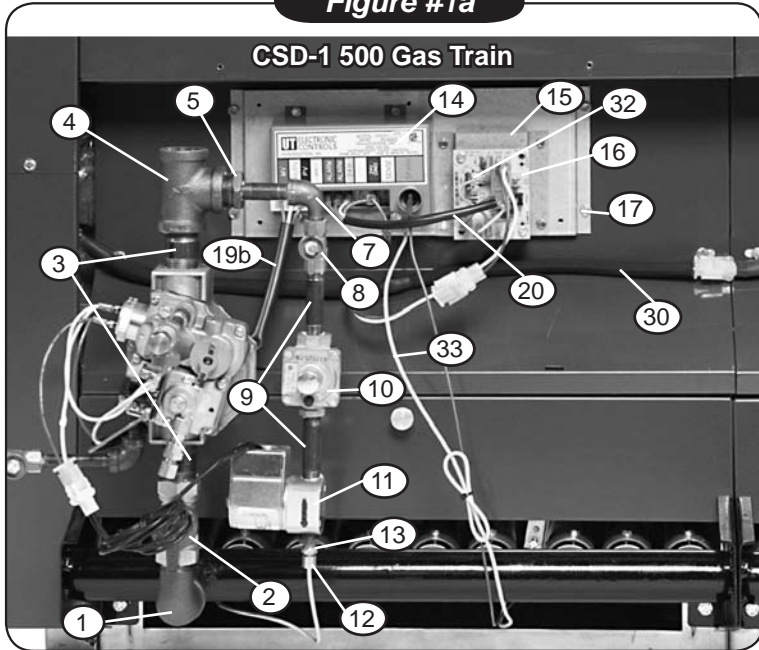

Figure #1b

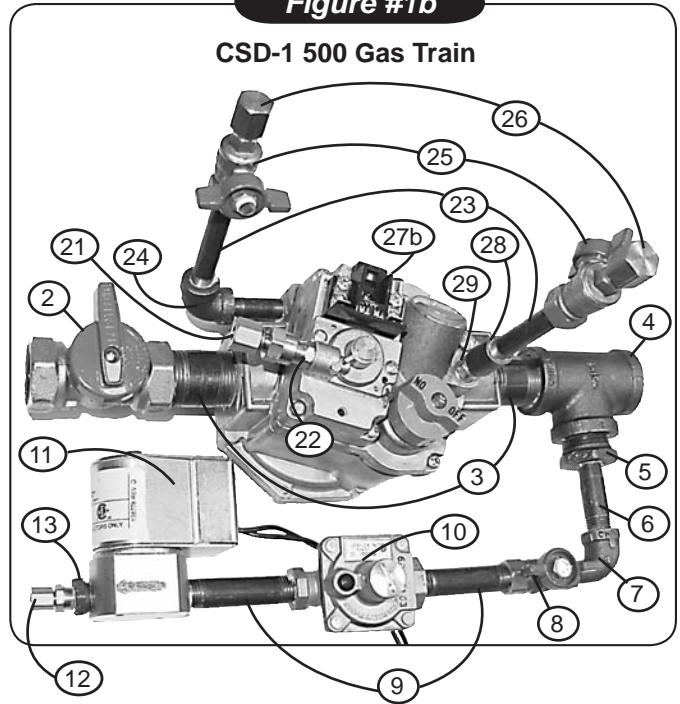

Table #3: CSD-1 Electronic Ignition Base Material List

| Item | Description | Part No. | Qty. |
|------|--|-----------|------|
| 1 | 3/4" 90 Street Elbow Back | 14693040 | 1 |
| 2 | 3/4" Manual Shutoff Valve | 14657001 | 1 |
| 3 | 3/4" x 2" Nipple Black | 14607201 | 2 |
| 4 | 3/4" Tee Black | 14693076 | 1 |
| 5 | 3/4" x 1/4" Bushing | 1060002 | 1 |
| 6 | 1/4" x 2" Nipple Black | 1310018 | 1 |
| 7 | 1/4" Street Elbow Black | 14657007 | 1 |
| 8 | 1/4" Manual Shutoff Valve | 14657002 | 1 |
| 9 | 1/4" x 2 1/2" Nipple Black | 14607000 | 2 |
| 10 | 1/4" Gas Pres. Regulator, 6" w.c. | 14657004 | 1 |
| 11 | 1/4" Magnetic Valve w/Connector Assembly | 43357103 | 1 |
| 12 | 1/8" NPT x 1/8" Tube M. Connector | 14657019 | 1 |
| 13 | 1/4" x 1/8" Bushing | 14657008 | 1 |
| 14 | Control STP W/Alarm | 1140007 | 1 |
| 15 | Control Mounting Panel, CSD-1 24 GA Galv | 109006833 | 1 |
| 16 | Control CSD Lockout Daughter Board | 1140008 | 1 |
| 17 | Control Mounting Panel | 109006832 | 1 |
| 18* | Screws, #8 x 3/8 Self Tap | 201000001 | 8 |

Table #3: Continued

| Item | Description | Part No. | Qty. |
|------|---|-------------|------|
| 19a* | Harness CSD-1 Control (300, 400) | 1263016 | 1 |
| 19b | Harness CSD-1 Control (500) | 1263019 | 1 |
| 20 | Harness CSD-1 Control | 240006623 | 1 |
| 21 | Compression Fitting, 1/8"NPT x 1/4" Tube | 14657025 | 1 |
| 22 | Brass Coupling, Male 1/8" x 5/16"-24 | 14657024 | 1 |
| 23 | 1/8" x 2 1/2" Nipple Black | 14607804 | 2 |
| 24 | 1/8" 90 Elbow (500 Only) | 14657010 | 1 |
| 25 | 1/8" Manual Shutoff Valve | 14657003 | 2 |
| 26 | 1/8" Pipe Cap | 14657012 | 2 |
| 27a* | Gas Valve, Electronic Ignition, Nat. (300, 400) | 14662315 | 1 |
| 27b | Gas Valve, Electronic Ignition, Nat. (500) | 14663001 | 1 |
| 28 | 1/8" Coupling Steel | 14657013 | 1 |
| 29 | CSD-1 Pilot Outlet Adapter | 43357104 | 1 |
| 30 | Wire Harness, Base to Base | 240006732 | 1 |
| 31* | 1/8 x 1 1/2, Nipple, Black (300, 400 Only) | 14657009 | 1 |
| 32 | Wire Jumper, CSD-1 Board (Orange) | 1263017 | 1 |
| 33 | Ground Wire, Spark (White) | 371-1-21.01 | 1 |

*Not Shown

HOT WATER SIDE CONTROLS

Hot Water Side Control - A low water cutoff with manual reset switch is required, which can be installed at any place on the water supply/return pipes above the boiler. An additional high temperature limit control with manual reset is also required, which shall be located in the boiler (Tapping D or F (See **Figure #2**)) or in the hot water

supply pipe at or near the supply tapping. A manual reset electronic probe type LWCO and manual reset temperature limit are included with the CSD-1 water carton, but the fittings between the pipes or boiler and the controls shall be supplied by the installer.

Table #4: CSD-1 Water Trim Carton Material List
(Part No. 41257102)

| Item | Description | Part No. | Qty. |
|------|---|-----------|------|
| 1 | LWCO, MAN RESET, CSD-1 APRVD, SHT PROBE | 240007388 | 1 |
| 2 | Aquastat (w/Manual Rest) | 1010003 | 1 |
| 3 | ½" Well Control | 14662804 | 1 |

STEAM SIDE CONTROLS

Steam Side Control - Two low water cutoff devices and two pressuretrols, one with auto reset and the second with manual reset, are required. **In order to make the two low water cutoff devices work in the appropriate sequence, it is recommended to locate both devices at the same end of the boiler.** There are three different control systems for three different types of condensate returns. Before describing these three control systems, it is beneficial to identify the three different types of condensate returns:

- **Gravity Return** - condensate is returned by gravity.
- **Condensate Pump Return** - condensate is returned by the pump(s), which is controlled according to the water level in the condensate receiver tank.
- **Boiler Feed Pump Return** - condensate is returned by the pump(s) which is controlled according to the water level in the boiler.

Figure #2

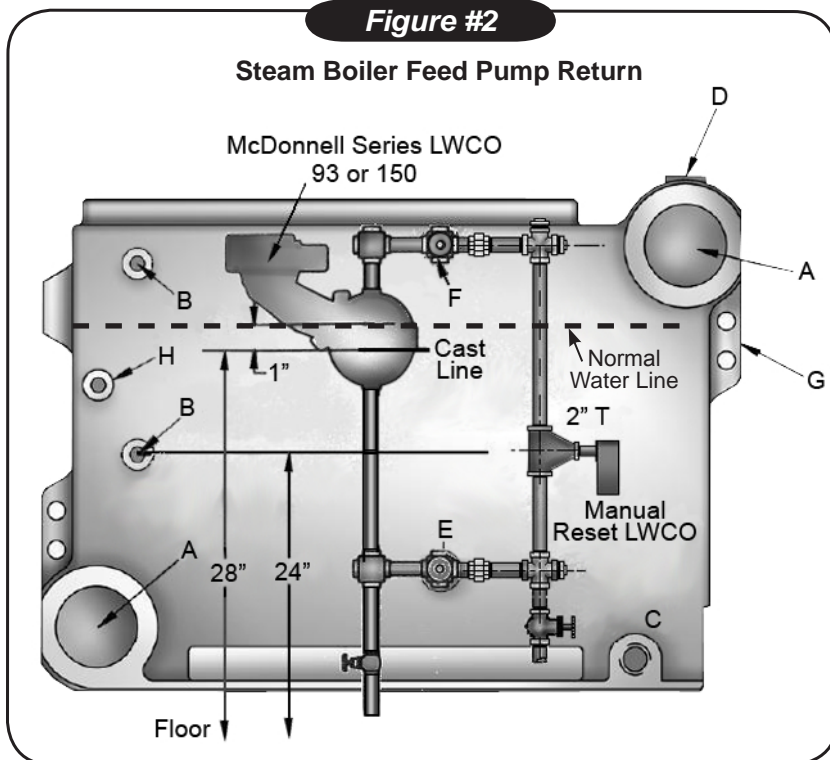
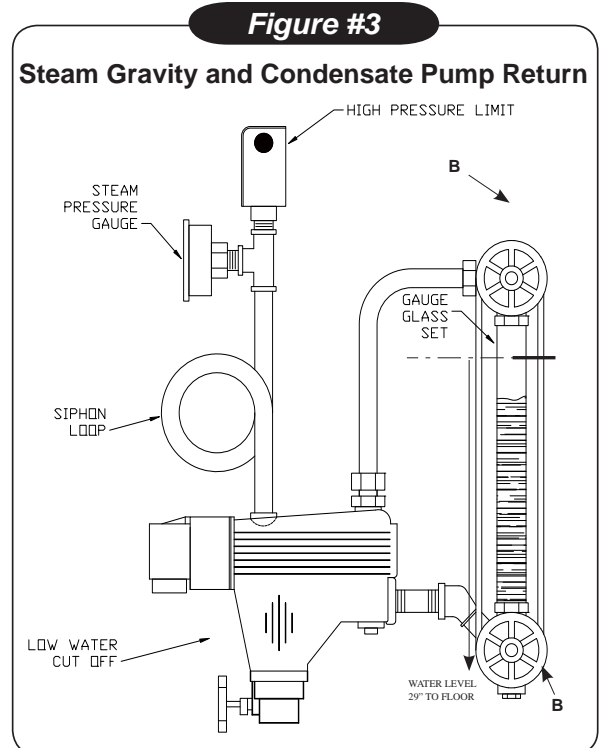

Figure #3



GRAVITY RETURN AND CONDENSATE PUMP RETURN

With the gravity and condensate pump return, the additional control components are identical and listed in **Table #5a**. **Figure #2** shows the tappings.

Tappings B & B location shown in **Figure #2** Installation shown in **Figure #3**, Primary LWCO and Pressuretrol with gauge glass set.

Tappings D or F (Figure #2)- Manual reset pressuretrol and ¼" 90° brass syphon.

Tappings E & F - Secondary LWCO (w/manual reset). **Must be used in conjunction with primary LWCO equipped on boiler.**

When using two LWCOs, the manual reset must be placed lower than the automatic LWCO, but water must still be visible in the gauge glass when the manual reset trips.

Figure 3 shows how to raise the automatic (Series 67) LWCO 1-inch. Remove 1" from the long side of the ¼" diameter 90 degree brass siphon tube. Remove the nipple in the series 67 and replace with the 1 ½" long nipple and street elbow. The water level control device that is located on the condensate receiver tank and controls the condensate return pump is not supplied.

Table #5a: CSD-1 Steam Trim Carton Material List for Gravity Return or Condensate Pump Return (Part No. 41257103)

| Item | Description | Part No. | Qty. |
|------|---------------------------------------|-----------|------|
| 1 | LWCO w/Manual Reset (secondary) | 240007388 | 1 |
| 2 | Bushing, Steel or Cast 1" x 1¼" | 14657016 | 1 |
| 3 | Pressure Switch Control, Manual Reset | 14662311 | 1 |
| 4 | 90° Brass Syphon, ¼" | 14643004 | 1 |
| 5 | ELB,ST,1/2",45 DEG.BRASS | 240007541 | 1 |
| 6 | NIPPLE 1/2" X 1/2"LG BRASS | 240007542 | 1 |

BOILER FEED PUMP RETURN

With the boiler feed pump return, the additional parts are presented in **Table #5b**. Refer to **Figure #2** for the installed locations of the additional parts.

Tappings B & B - Water gauge glass set and pressuretrol (requires fittings 4-7 in **Table #5b**).

Tapping D - Steam gauge and pressuretrol (requires fitting 8 in **Table #5b**).

Tappings E & F - LWCO (auto and manual) and pump control. Installers need to supply and size the steam (top) and water (bottom) equalizing pipe lengths so that the horizontal cast line on the control body is 28" above the floor. The secondary control is 24" above the floor. (**Figure #2**)

Table #5b: CSD-1 Steam Trim Carton Material List For Boiler Feed Pump Return (Part No. 41257104)

| Item | Description | Part No. | Qty. |
|------|---|-----------|------|
| 1 | Pressure Switch Control, Manual Reset | 14662311 | 1 |
| 2 | LWCO and Pump Control (primary) | 14626306 | 1 |
| 3 | LWCO, MAN RESET, CSD-1 APRVD, SHT PROBE | 240007388 | 1 |
| 4 | 90° Brass Syphon, ¼" | 14643004 | 1 |
| 5 | Brass Nipple, ½" x 3½" | 14607024 | 2 |
| 6 | Brass Tee, ½" x ½" x ¼" | 14693051 | 2 |
| 7 | Brass Coupling, ½" | 14693052 | 2 |
| 8 | Bushing, ½" x ¼" | 1060001 | 1 |

SEQUENCE OF OPERATION

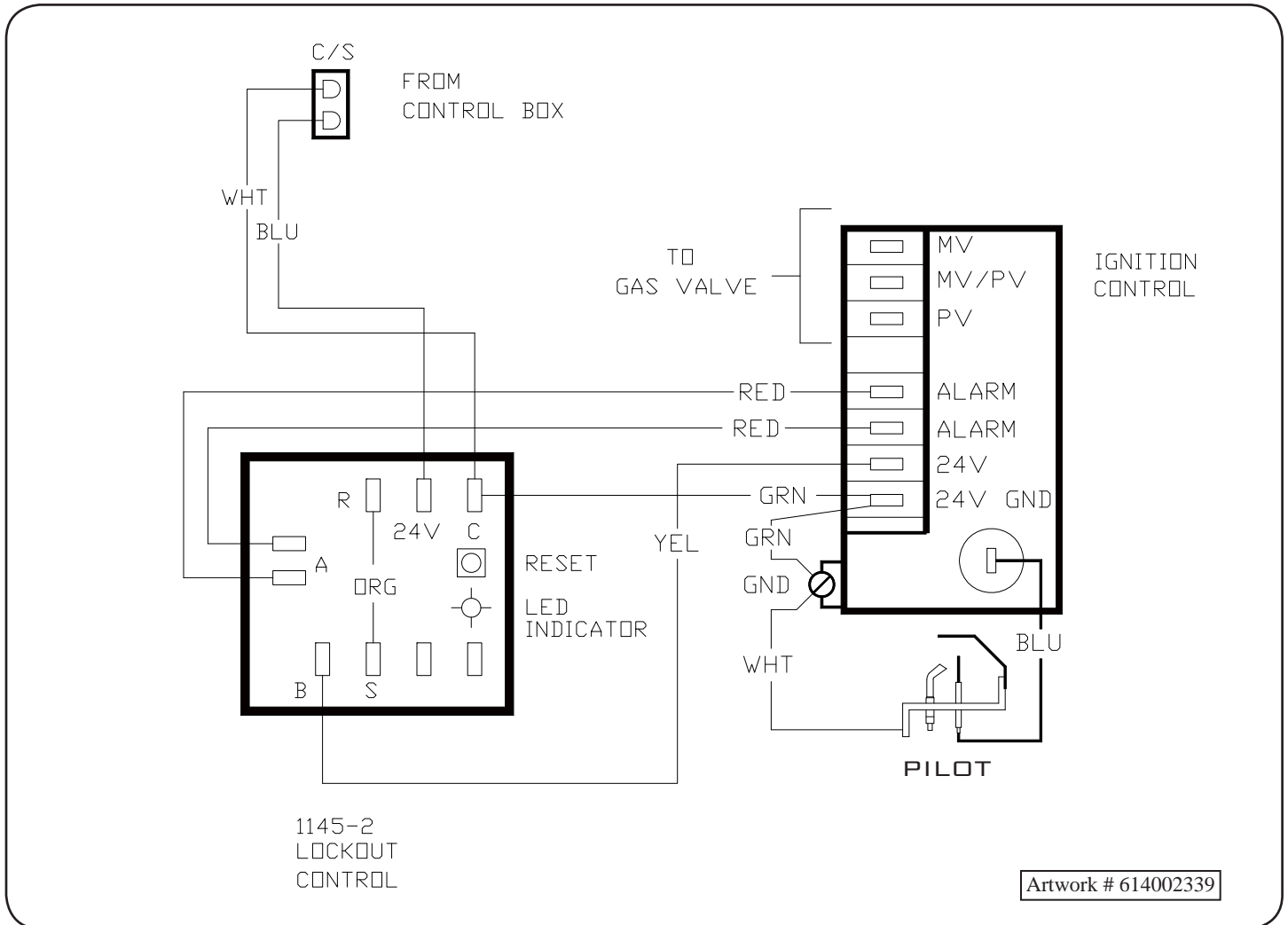

CALL FOR HEAT

The control recognizes a call for heat when power is applied to the 24V terminal on the control module. Since the control receives its signal from the thermostat, any time the call for heat is terminated, the heating cycle will be immediately terminated and all control outputs will shut off.

IGNITION TRIAL PERIOD

The control energizes the pilot gas valve and spark outputs for an ignition trial time of 12 seconds. If flame is sensed during the 12 seconds of ignition trial, the spark output is de-energized, the main gas valve is energized, and the control enters steady heat mode. If flame is not

established within the ignition trial period, the control de-energizes the spark and gas valve and operates as described below in *"Ignition Failure/Re-try Sequence."*

IGNITION FAILURE/RE-TRY SEQUENCE

After an unsuccessful ignition trial, the control checks to see if the maximum number of ignition trials (2 trials) has been completed. If the maximum number of ignition trials has been completed, the control will lockout. See the section titled *"Lockout"* (next page) for details.

If the maximum number of ignition trials has not been completed, the control delays for a 5 minute inter-purge period. After the inter-purge, the control attempts another ignition trial. Refer back to *"Ignition Trial Period"* for details.

SEQUENCE OF OPERATION

STEADY-STATE HEATING

The control keeps the pilot gas valve and main gas valve energized while continuously monitoring the call for heat and flame status. The control will then remain in this steady-state heating mode until power is removed by (a) the thermostat satisfied, (b) the pressure switch opening, or (c) the flame being lost.

If the call for heat is satisfied, power is removed from the control, de-energizing the pilot gas valve and main gas valve.

If the flame is lost, the control will shut off the main gas valve within one second, leave the pilot gas on, and immediately start an ignition trial. The control then checks to see if the maximum number of flame losses (2 per call for heat) has been reached. If the maximum number of flame losses has been reached, the control locks out. See the section titled “*Lockout*” for details.

GAS VALVE SENSING

If either or both the pilot and main gas valves are sensed to be on when commanded to be off, or if no voltage appears at a gas valve output which was commanded on, the control will shut off all outputs and enter either a “*soft*” or “*hard*” lockout state. The main valve is interlocked with the pilot valve and voltage can only be detected on the main valve when the pilot valve is energized. The control locks out the first time as a “*soft*” lockout, then retries after 5 minutes and enters a “*hard*” lockout state. At this point, the lockout should be manually reset as described in “*Lockout*.”

FLAME PRESENT WITH GAS OFF

If flame is sensed for longer than 2 seconds during a period when the gas valve should be closed, the control will enter lockout.

POWER INTERRUPTIONS

Power interruptions less than 0.15 seconds will not cause the control to interrupt the heat sequence while power interruptions over 0.25 seconds will cause the control to reset lockout and ignition trial counters. Power interruptions of any duration will not cause a lockout or any other operation requiring manual intervention.

LOCKOUT

The controller will automatically reset from the first lockout in 5 minutes. If a second lockout occurs before the call for heat is satisfied, it will require manually resetting by depressing the red button on the CSD-1 daughter board. This can be reached with a pencil through the vent holes. A red LED will also indicate lockout and can be seen through the vent holes.

ELECTRICAL WIRE DIAGRAMS - GAS VALVE CONTROL WIRING

The suggested schematic wiring diagrams are included. Please use the appropriate one for the installation.

CSD-1 HONEYWELL VR8304M,H MAIN GAS VALVE CONTROL WIRING

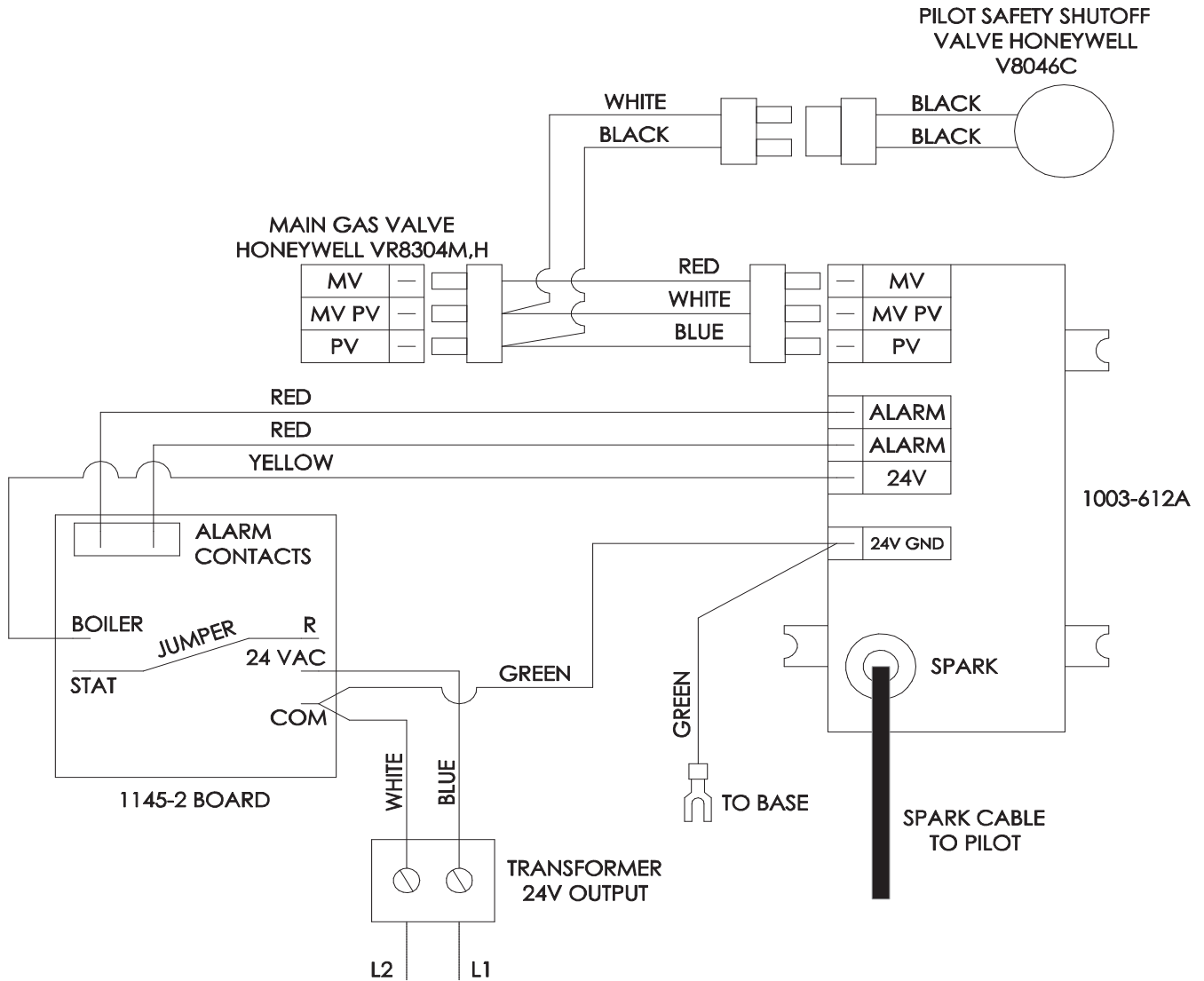

Artwork # A2410

ELECTRICAL WIRE DIAGRAMS - GAS VALVE CONTROL WIRING

The suggested schematic wiring diagrams are included. Please use the appropriate one for the installation.

CSD-1 ROBERT SHAW 7000 DE RHC GAS VALVE CONTROL WIRING

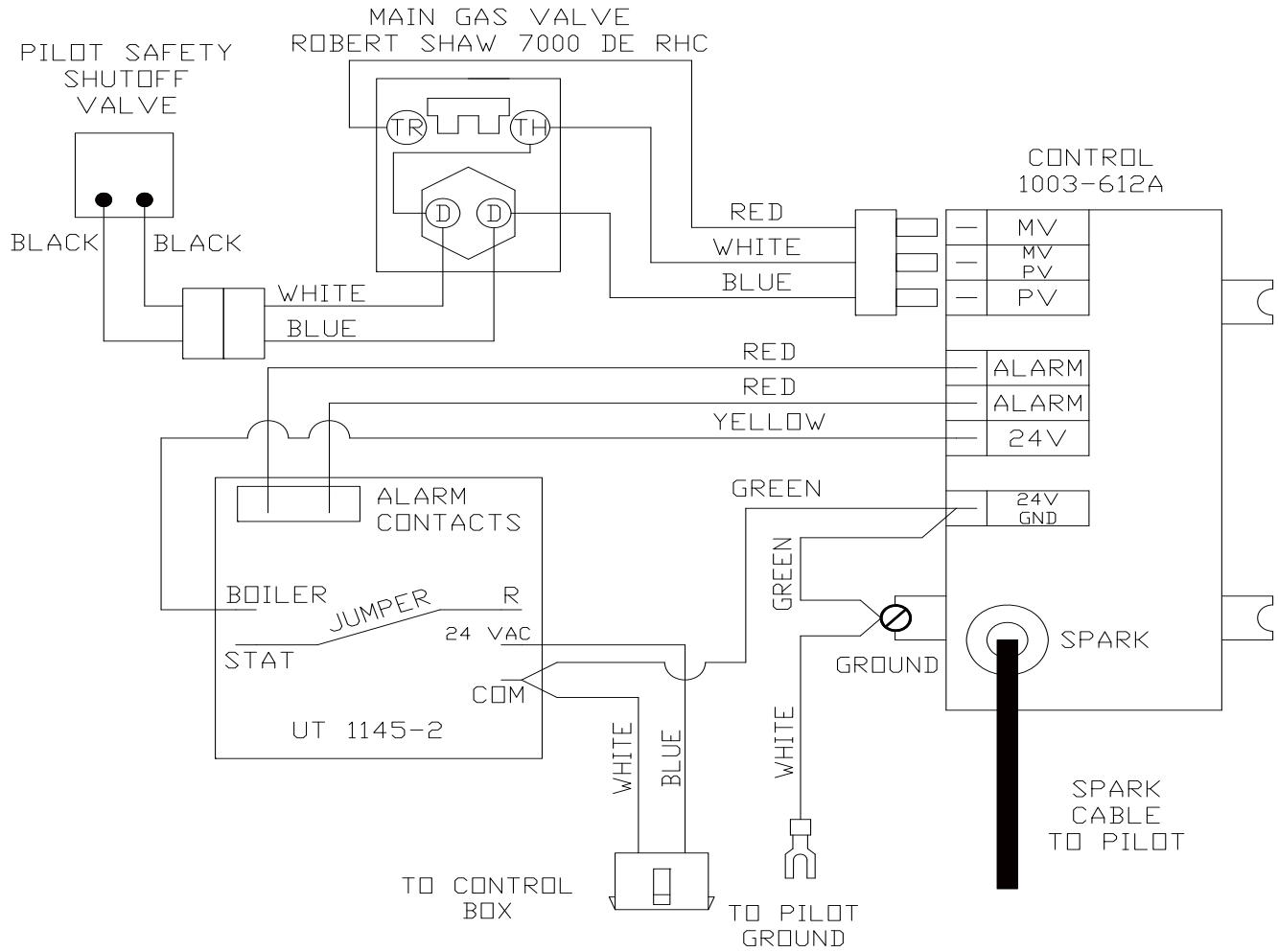

Artwork # A2411 rev2

ELECTRICAL WIRE DIAGRAMS - CSD-1 HOT WATER BOILERS

COMMERCIAL BOILER, CSD-1 CONTROLS, 1-BASE, WATER SYSTEM

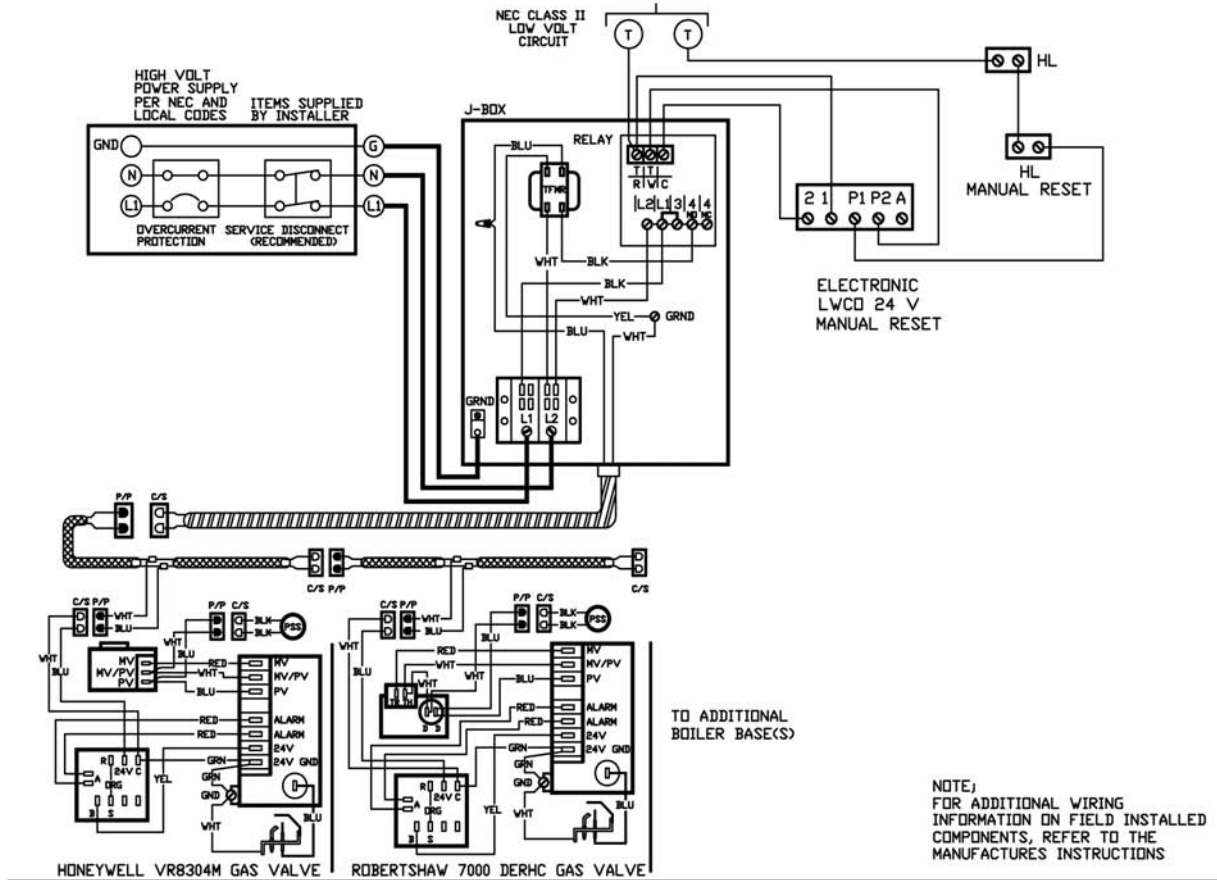

WIRING SCHEMATIC HIGH VOLT POWER SUPPLY

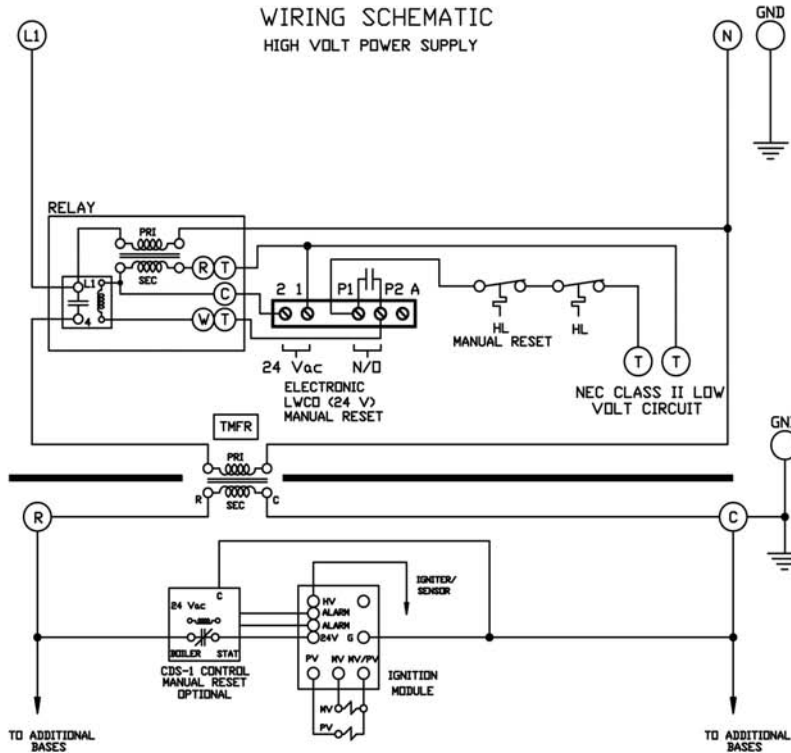

LEGEND

- HL = HIGH LIMIT
- MV = MAIN VALVE
- PV = PILOT VALVE
- PSS = PILOT SAFETY SWITCH
- P/P = PLUG/PIN
- C/S = CAP/SOCKET

- HIGH VOLT FIELD INSTALLED
- LOW VOLT FIELD INSTALLED

LOW VOLTAGE WIRING

ELECTRICAL WIRE DIAGRAMS - CSD-1 HOT WATER BOILERS

COMMERCIAL BOILER, CSD-1 CONTROL, 2-6 BASE WATER SYSTEM

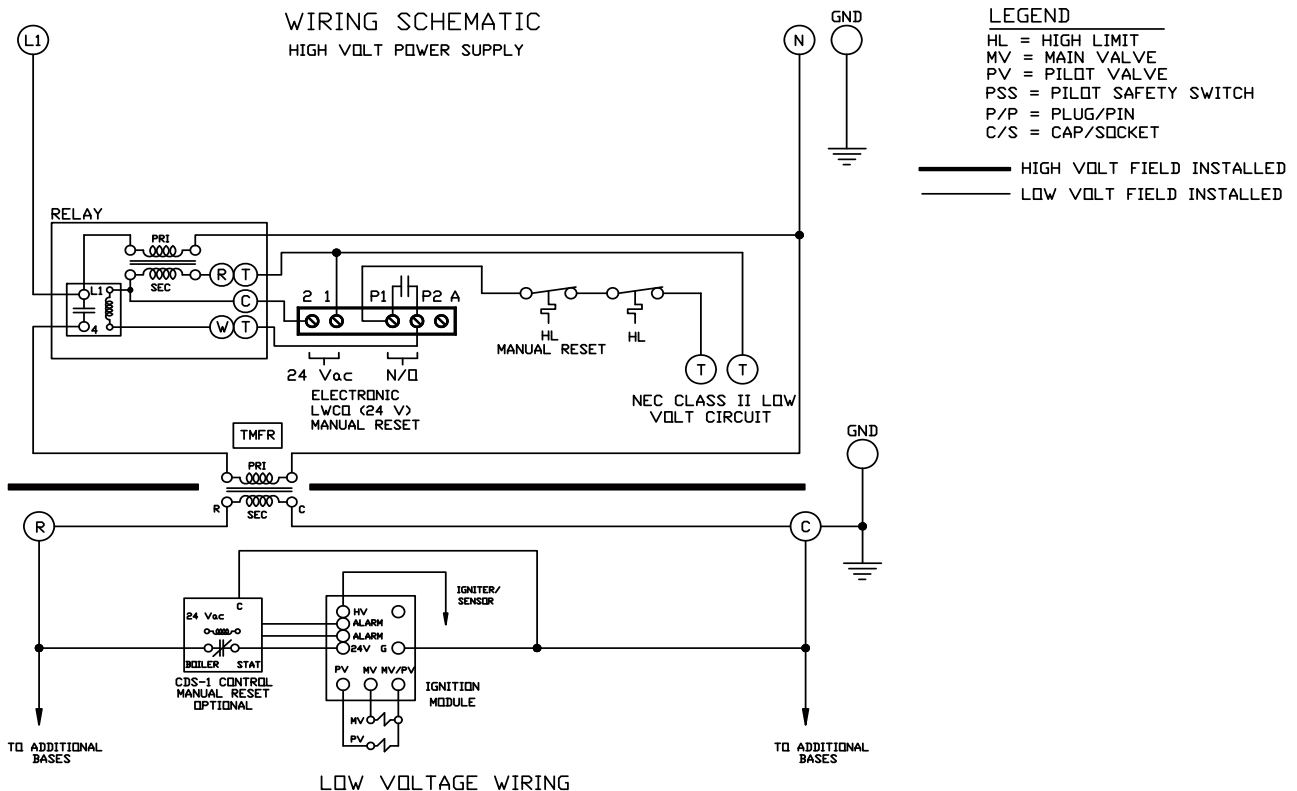
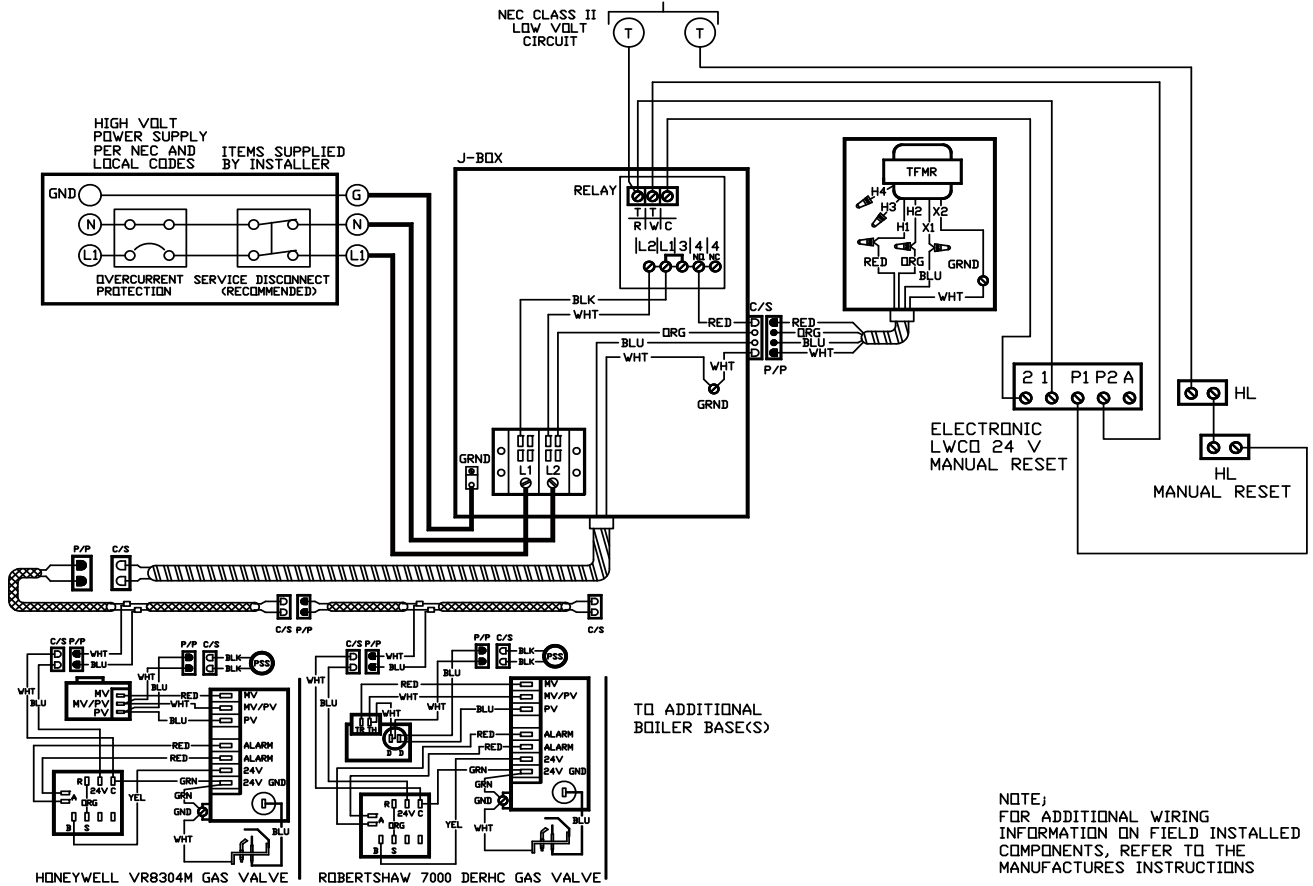

ELECTRICAL WIRE DIAGRAMS - CSD-1 STEAM BOILERS WITH CONDENSATE PUMP/GRAVITY RETURN

COMMERCIAL BOILER, CSD-1 CONTROL, 1-BASE, STEAM, GRAVITY/COND.

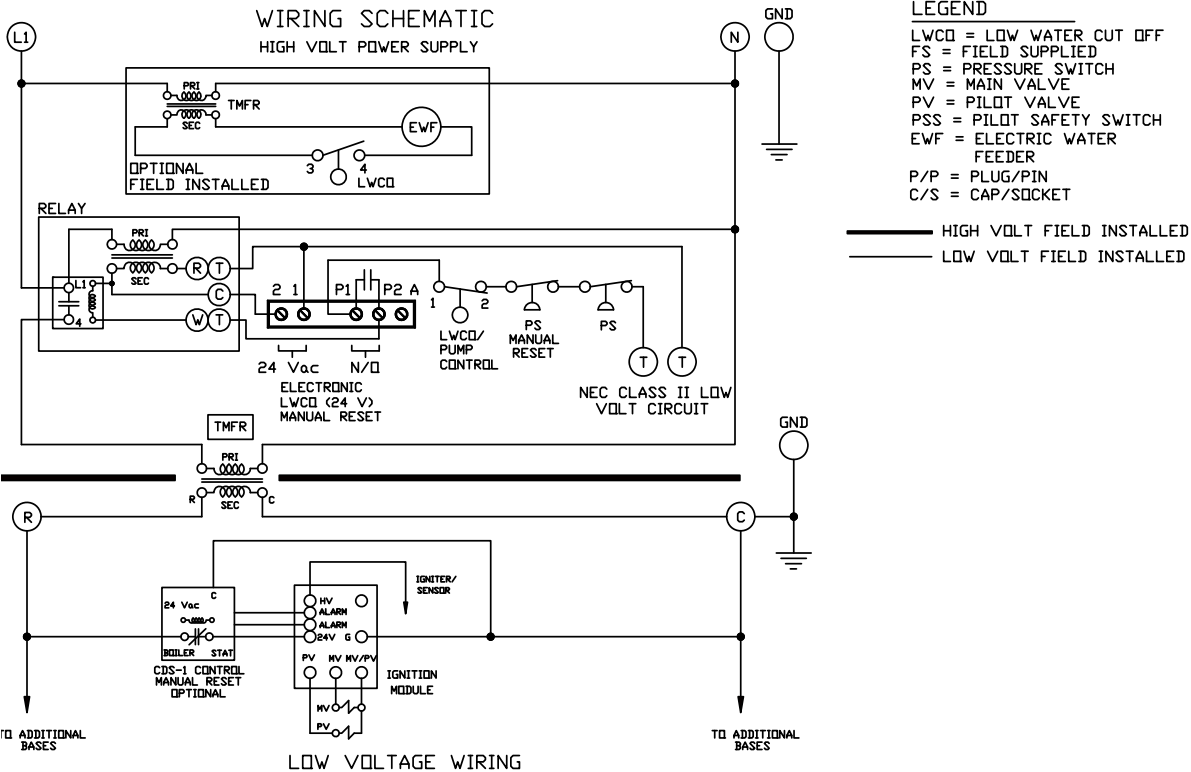
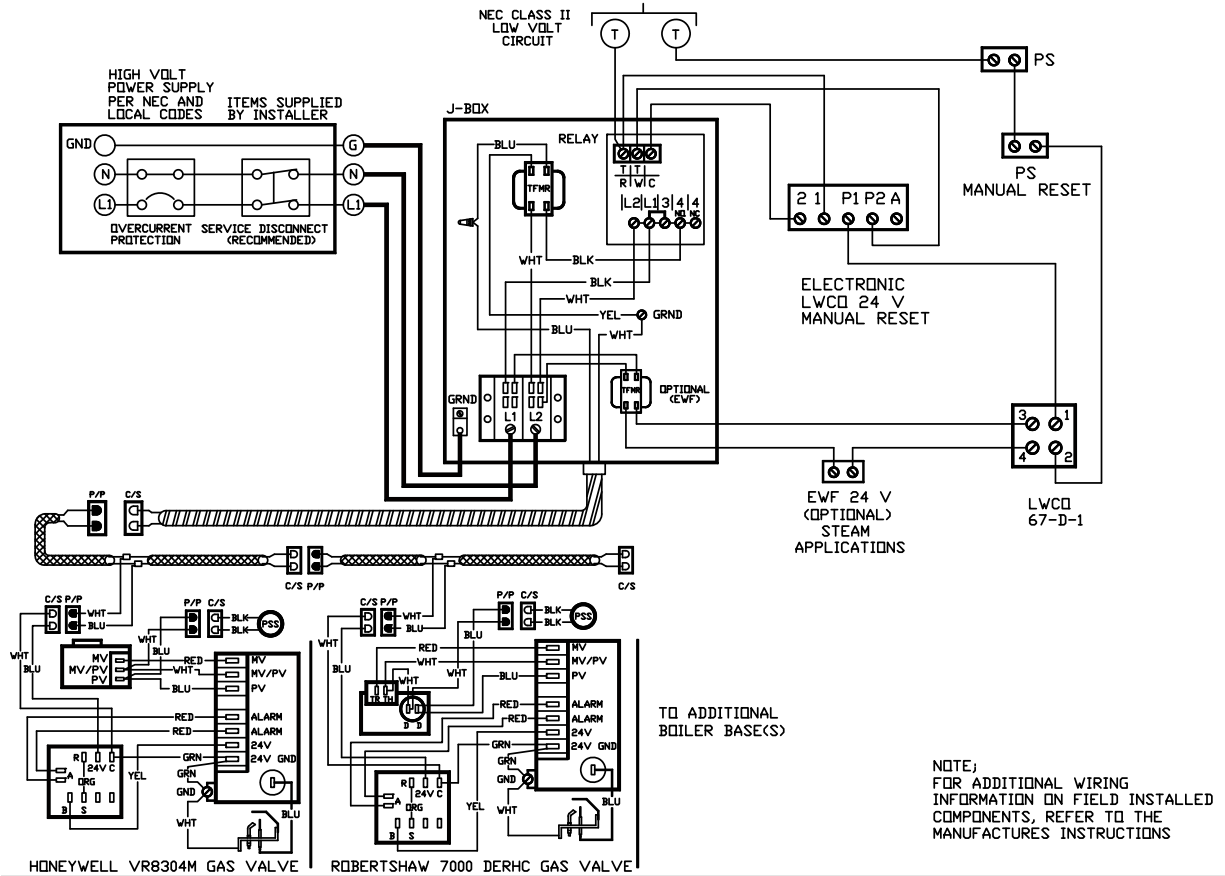

ELECTRICAL WIRE DIAGRAMS - CSD-1 STEAM BOILERS WITH CONDENSATE PUMP/GRAVITY RETURN

COMMERCIAL BOILER, CSD-1 CONTROL, 2-6 BASE, STEAM, GRAVITY/COND.

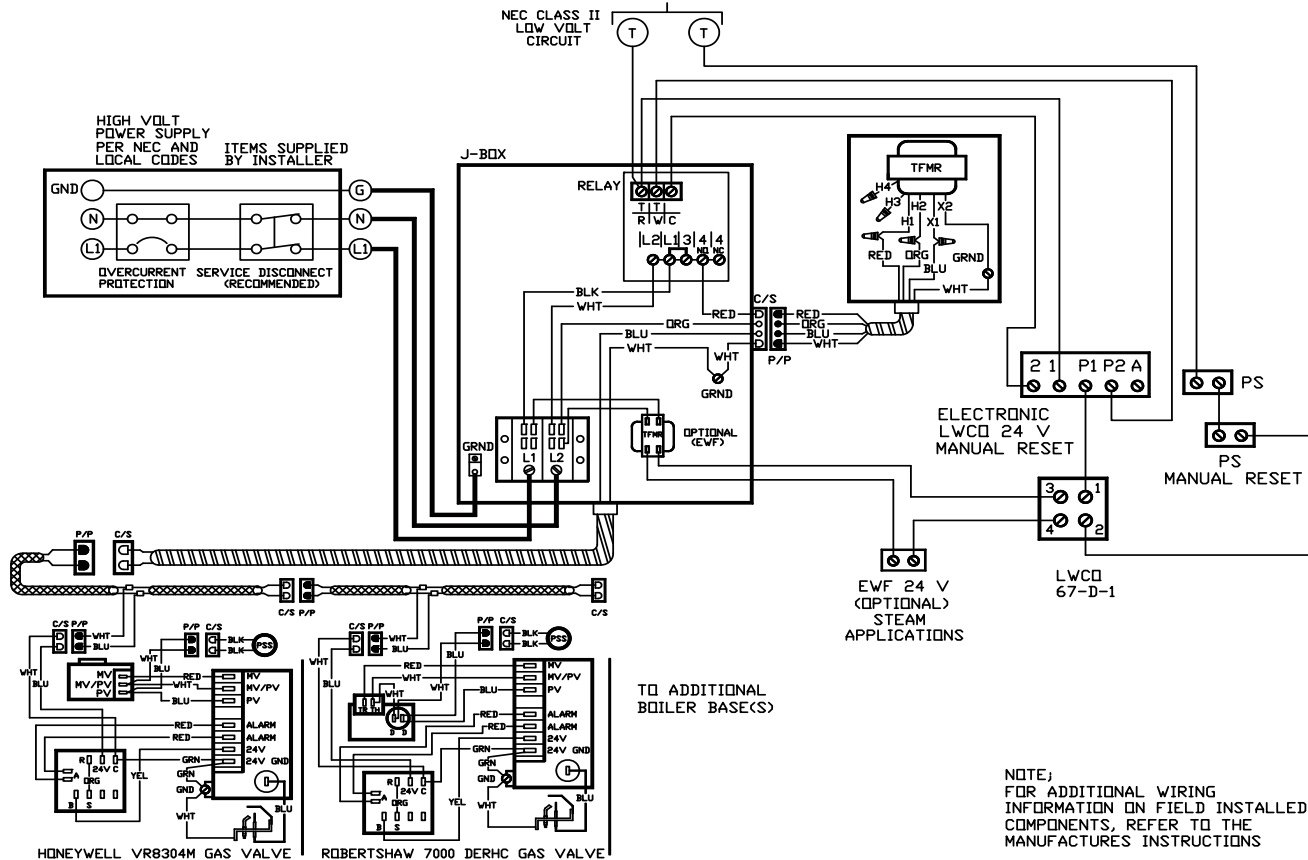

WIRING SCHEMATIC HIGH VOLT POWER SUPPLY

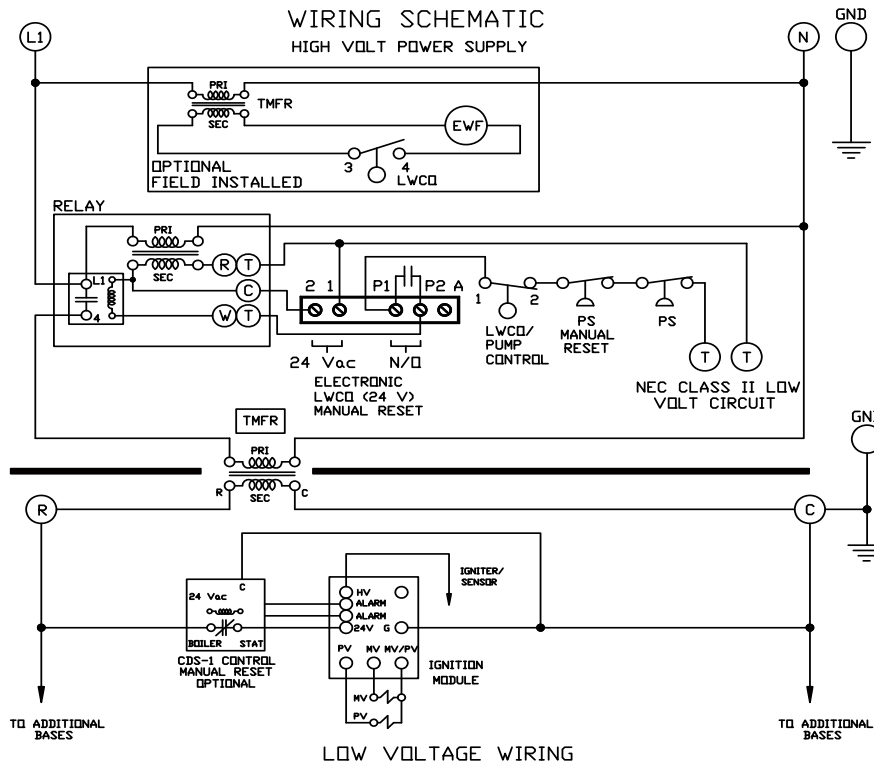

LEGEND

- LWCO = LOW WATER CUT OFF
- FS = FIELD SUPPLIED
- PS = PRESSURE SWITCH
- MV = MAIN VALVE
- PV = PILOT VALVE
- PSS = PILOT SAFETY SWITCH
- EWF = ELECTRIC WATER FEEDER
- P/P = PLUG/PIN
- C/S = CAP/SOCKET

- HIGH VOLT FIELD INSTALLED
- LOW VOLT FIELD INSTALLED

ELECTRICAL WIRE DIAGRAMS - CSD-1 STEAM BOILERS WITH BOILER FEED PUMP RETURN

COMMERCIAL BOILER, CSD-1 CONTROLS, 1-BASE, STEAM, FEED PUMP

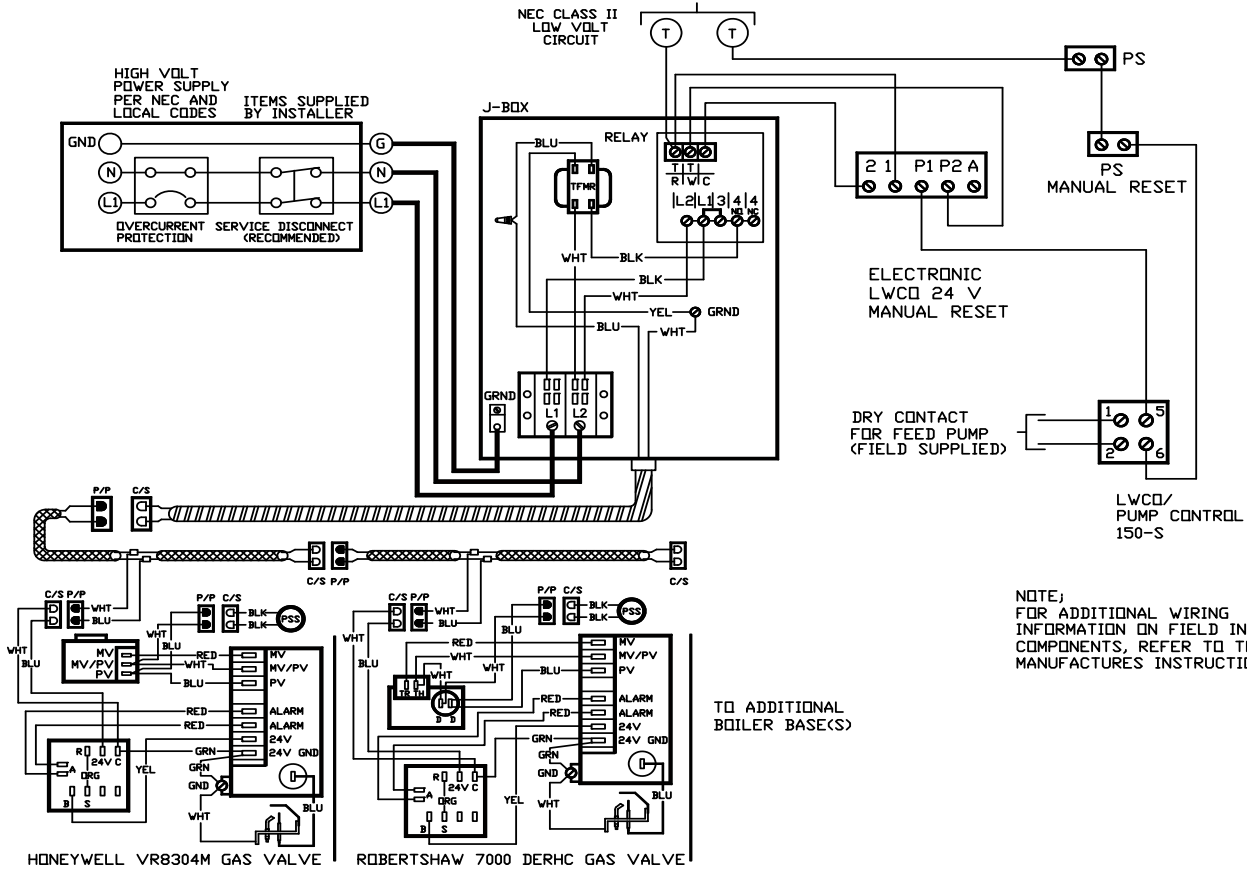

WIRING SCHEMATIC HIGH VOLT POWER SUPPLY

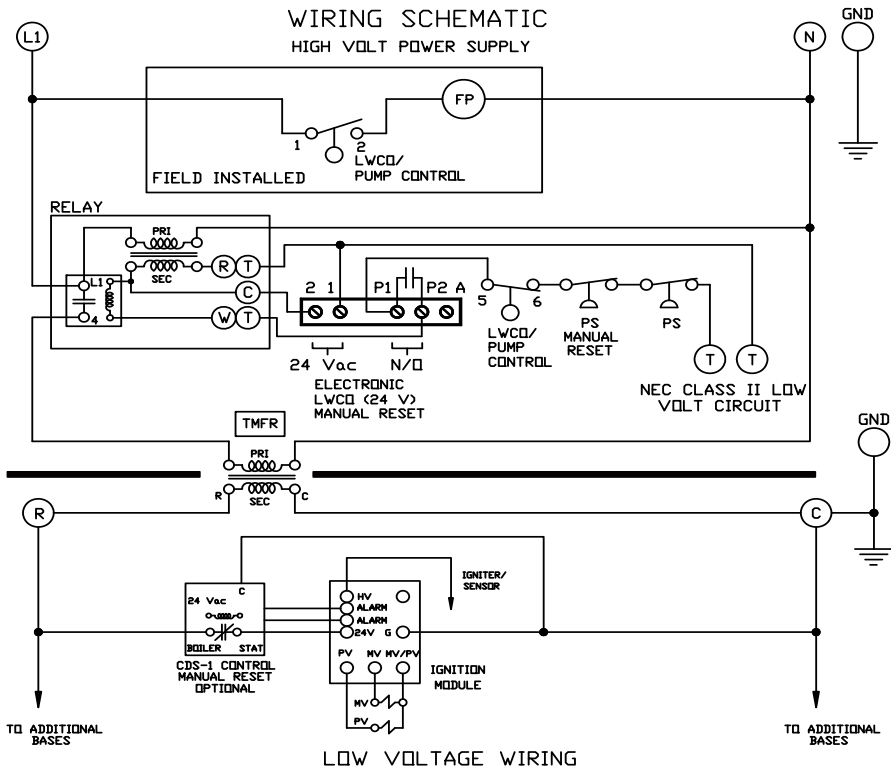

LEGEND

- LWCO = LOW WATER CUT OFF
- PS = PRESSURE SWITCH
- MV = MAIN VALVE
- PV = PILOT VALVE
- PSS = PILOT SAFETY SWITCH
- FP = FEED PUMP
- P/P = PLUG/PIN
- C/S = CAP/SOCKET

- HIGH VOLT FIELD INSTALLED
- LOW VOLT FIELD INSTALLED

ELECTRICAL WIRE DIAGRAMS - CSD-1 STEAM BOILERS WITH BOILER FEED PUMP RETURN

COMMERCIAL BOILER, CSD-1 CONTROL, 2-6 BASE, STEAM, FEED PUMP

