

EXCELSIOR

OIL-FIRED HIGH EFFICIENCY 3-PASS WATER BOILER

*Quality Engineered for
Efficiency and Dependability*

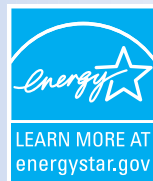

Dunkirk®

America's Hottest Boiler Value!
An ISO 9001-2000 Certified Company



EXCELSIOR

THE NEXT GENERATION OIL BOILER

Excelsior – The Green Choice in Oil Boilers with up to 86.5% AFUE!

Advanced High Efficiency 3-Pass Heat Exchanger Design

The Excelsior's multiple flue-way passages maximize surface area, optimizing heat transfer. Standard stainless steel baffles further enhance efficiency. A compact low mass design allows the unit to recover from low standby water temperatures utilizing half the energy of standard oil boilers. The overall result – a greener oil boiler through improved technology, ideal for space heating and applications utilizing an indirect water heater.

Burners, Venting & Packaging Options

With a wide range of ENERGY STAR efficient models from .75 to 1.65 GPH, chimney or direct vent, Beckett or Riello Burners and packaging choices including knockdown – the Excelsior is tailored to the needs of your application.

Compact Footprint

With the leanest design in its class, the Excelsior eases into tight applications while being easier on you. Compact and strong, maximum allowable working pressure of 65 psi.

E-A-S-Y Installation Plug 'n Play

Piping

The Excelsior Series features an installer friendly Piping Tree clearly labeled for simple, efficient installation of standard Aquastat, Pressure/Temperature Gauge and Relief Valve as well as optional Low Water Cut Off and High Limit Control. Piping connections are conveniently located at the back of the unit so the jacket can be installed after the unit has been piped.

Wiring

The Excelsior features an easily accessible terminal block located under the top protective cover. The unit is factory wired with molex connections for the Burner, Main Control, High Limit and Low Water Cut Off.

Warranty

Excelsior features a limited lifetime warranty with 5 and 10 Year Comfort Plus Extended Parts and Labor Warranties available.

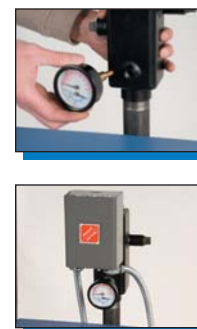
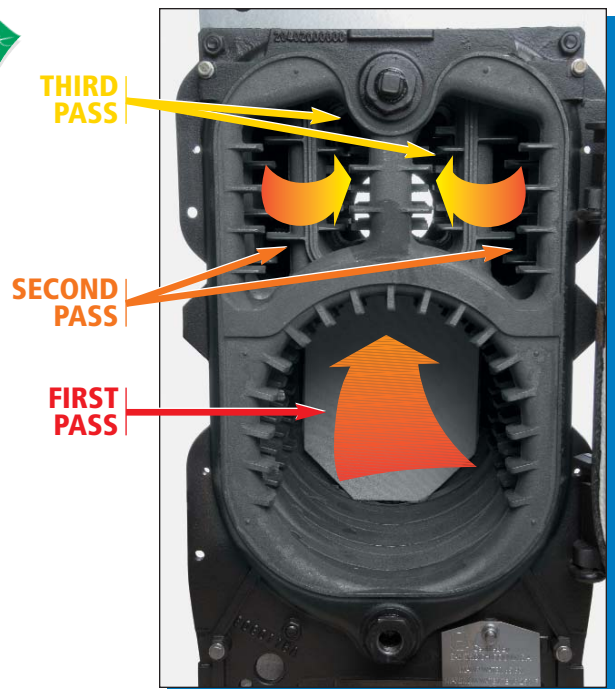

Piping Manifold Tree for quick installation of standard features and optional controls.

Panels can be installed or removed after the piping is connected

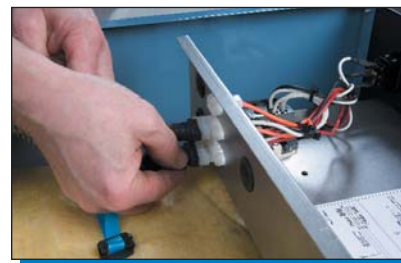

Controls come standard with factory wiring and plug 'n play harnesses

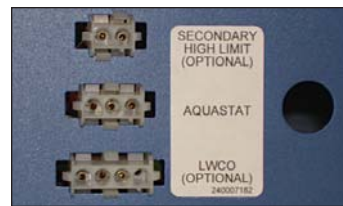

Plug 'n play connections for optional High Limit and LWCO



Beckett burner with plug 'n play connector



Reversible swing door for installation flexibility



Wide Flue-Ways for easy cleaning



Site Glass & Sample port for easy service



Reversible hinged door easily lifts off hinges and positions right or left



Hinge-Mount



Removable front panel for easy cleaning and service



Flexible Oil Line

E-A-S-Y Service

Dealer-Driven Features include:

- Flexible oil line combined with an easy access heat exchanger featuring dual hinge swing door with right or left mount option
- Wide Flue-Ways for easy cleaning
- Site Glass for flame observation
- Removable 1/4" sampling port for combustion readings

EXCELSIOR FACTORY SUPPLIED STANDARD EQUIPMENT

- High Efficiency Cast Iron 3-Pass Heat Exchanger
- Combination Powder-Coated Steel/Plastic Jacket
- Lighted On/Off Switch with Protective Cover
- Reversible Dual Hinged Swing-Out Burner Door
- Oil Burner with Protective Sound Retention Cover
- Target Wall
- Liner as Required by Model
- Efficiency Baffles by Model
- 3/4" ASME Relief Valve
- Piping Tree
- 1-1/4" Supply & Return Tappings (Qty. 1 ea.)
- Temperature/Pressure Gauge
- Aquastat/Boiler Control
- Circulator Control
- Terminal Block for Power Wiring
- Wiring Harnesses with Molex Connectors
- Burner Electrical Disconnect
- Drain Valve

OPTIONAL EQUIPMENT

- Low Water Cut Off and/or Manual Reset High Limit are factory pre-wired and include plug 'n play molex connector harnesses
- Quick Connect Harness
- Knock-Down Packaging
- Burner Choices - Riello/Beckett AFG
- Direct Vent

Direct Vent



Flexible Vent Pipe



Standard Vent Termination

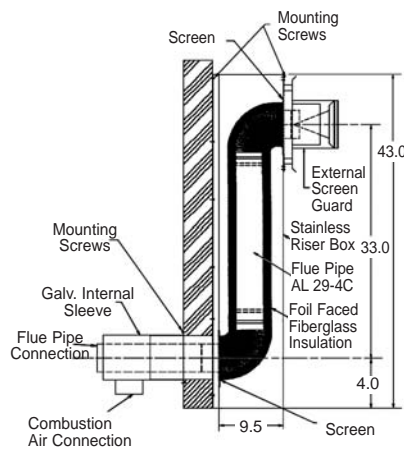

Riser Vent termination

DIRECT VENT BOILERS

Now Available with Beckett NX or Riello 40BF Burners

- Flexible Side Wall Venting Kits
 - 10, 15, 20 feet of double wall insulated stainless flexible vent pipe available as kits
- Termination Kits (2 Available Options)
 - Standard Vent Termination Kit
 - Riser Vent Termination Kit

Kits are not included with boiler.

EXCELSIOR *Oil-Fired High Efficiency 3-Pass Water Boiler*

RATINGS & CAPACITIES

MODEL NO.	NO. OF SEC.	INPUT **MBH	***HEATING CAPACITY **MBH	NET I=B=R RATING **MBH	FIRING RATE †GPH	CHIMNEY SIZE	BOILER FLUE	DIMENSIONS (INCHES)			A.F.U.E. ††	APPROX. SHIP WEIGHT
								A	B	C		
*DK4EXA075	4	105	90	79	0.75	8" x 8" x 15'	5"	17 3/4	17 3/4	34 1/4	86.0%	436
*DK5EXA100	5	140	120	105	1.00	8" x 8" x 15'	5"	20 7/8	17 3/4	34 1/4	86.5%	496
*DK6EXA130	6	182	157	136	1.30	8" x 8" x 15'	5"	24 1/8	17 3/4	34 1/4	86.5%	560
*DK7EXA165	7	231	198	172	1.65	8" x 8" x 15'	6"	27 1/2	17 3/4	34 1/4	85.8%	620

NOTE: For direct vent applications, boiler must be ordered as a direct vent version. Field conversion kits are not available to convert the standard boiler to a direct vent version.

* AS AN ENERGY STAR PARTNER, DUNKIRK HAS DETERMINED THAT THIS PRODUCT MEETS ENERGY STAR GUIDELINES FOR ENERGY EFFICIENCY.

** MBH = 1,000 BTU PER HOUR
BTU = BRITISH THERMAL UNIT

*** HEATING CAPACITY BASED ON 13% CO₂ WITH A -0.02" W.C. DRAFT AT BREECH, AND A #1 SMOKE OR LESS. TESTING WAS DONE IN ACCORDANCE WITH THE D.O.E. (DEPARTMENT OF ENERGY) TEST PROCEDURE.

† GPH = GALLONS PER HOUR OIL AT 140,000 BTU PER GALLON

†† A.F.U.E. = ANNUAL FUEL UTILIZATION EFFICIENCY BASED UPON D.O.E. TEST PROCEDURE.

DIMENSIONAL DIAGRAM

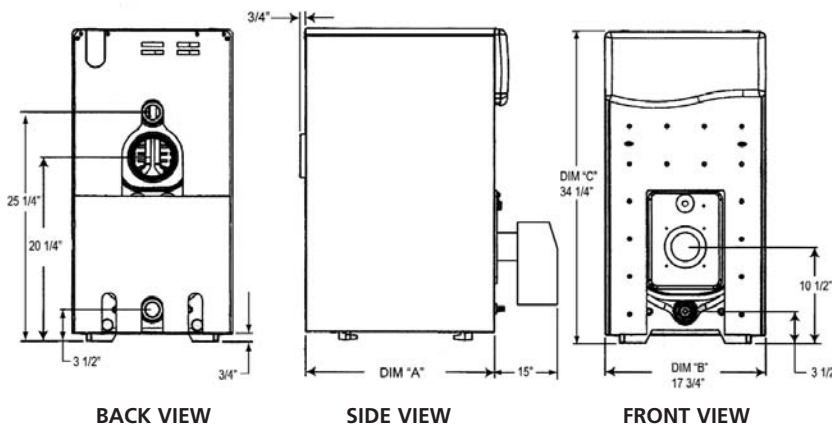

BACK VIEW

SIDE VIEW

FRONT VIEW

- The ratings marked "Net I=B=R Ratings" indicate the amount of remaining heat input that can be used to heat the radiation or terminal units. The Net I=B=R ratings shown are based on an allowance of 1.15 in accordance with the factors shown in the I=B=R Code as published by the Hydronics Institute.
- Selection of boiler size should be based upon "Net I=B=R Rating" being equal to or greater than the calculated heat loss of the building.
- The manufacturer should be consulted before selecting a boiler for installations having unusual piping and pick-up requirements.
- These boilers are constructed and hydrostatically tested for a maximum working pressure of 65 psi in accordance with A.S.M.E. (American Society of Mechanical Engineers) Boiler and Pressure Vessel Code Section IV standards for cast iron heating boilers. They are capacity rated in accordance with the code of the Hydronics Institute.

DUNKIRK QUALITY HEATING. *America's Hottest Boiler Value!*

Dunkirk hydronic boilers lead the industry in value, with premium quality design and componentry. In fact, some of the most respected "brand name" boilers are produced by Dunkirk. These major manufacturers selected Dunkirk hydronic boilers for the same basic reasons you should: superb quality and unmatched value. Just compare our quality to cost ratio, and your boiler choice will become perfectly clear.

Specifications and dimensions are subject to change without notice. Made in America by American Craftsmen.



Since 1928. America's Hottest Boiler Value.



An ISO 9001-2000 Certified Company



P.O. Box 4729 Utica, New York 13504
Phone: 315-797-1310 Fax: 866-432-7329
Corp. Sales Phone: 877-386-5475
Corp. Sales Fax: 716-366-4670



**USA Contractor Assistance:
800-325-5479**