

Cast Iron Commercial Hot Water Or Steam Boiler

REPAIR PARTS

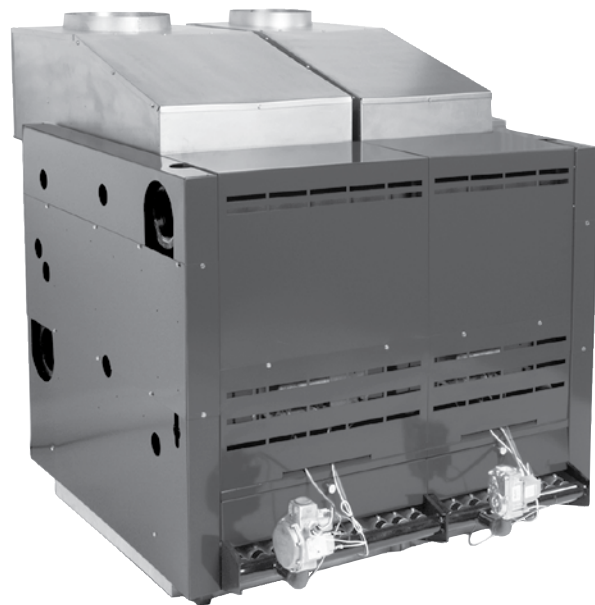

COMPLETE BOILER MATERIAL LIST

COMPLETE BOILER MATERIAL LIST

Model	MODEL		*COMPONENT CART.			STEAM TRIM CARTON	**WATER TRIM CARTON	***STEAM TRIM CARTON	STEAM TRIM LESS LOW WATER CUTOFF	+AC CARTON	++JACKET END PANEL CARTON		+++BASE END PANEL CARTON	
			300	400	500						QTY.	ITEM #	QTY.	ITEM #
			QTY	QTY	QTY						ITEM #	ITEM #	ITEM #	ITEM #
	L	INNER	R	41154051	41154052	41154050								
300	1	2	1	1	550001661	-	-	1	300	1	1	1	1	
400	1	3	1	1	-	1	-	400	400	1	1	1	1	
500	1	4	1	1	-	-	1	500	500	1	1	1	1	
600	1	5	1	1	2	-	-	600	600	1	1	1	1	
700	1	6	1	1	1	1	-	700	700	1	1	1	1	
800	1	7	1	1	-	2	-	800	800	1	1	1	1	
900	1	8	1	1	-	1	1	900	900	1	1	1	1	
1000	1	9	1	1	-	-	2	1000	1000	1	1	1	1	
1100	1	10	1	1	1	2	-	1100	1100	1	1	1	1	
1200	1	11	1	1	-	3	-	1200	1200	1	1	1	1	
1300	1	12	1	1	1	-	2	1300	1300	1	1	1	1	
1400	1	13	1	1	-	1	2	1400	1400	1	1	1	1	
1500	1	14	1	1	-	-	3	1500	1500	1	1	1	1	
1600	1	15	1	1	-	4	-	1600	1600	1	1	1	1	
1700	1	16	1	1	1	1	2	1700	1700	1	1	1	1	

COMPLETE BOILER MATERIAL LIST

1800	1	17	1	-	2	550001662	2	550001663	WA-4	SA-4	41200069	1800 550001691	1	1
1900	1	18	1	-	1	550001662	3	550001663	WA-4	SA-4	41200069	1900 550001692	1	1
2000	1	19	1	-	-		4	550001663	WA-4	SA-4	41200069	2000 550001693	1	1
2100	1	20	1	2 550001661	-		3	550001663	WA-4	SA-4	41200069	2100 550001694	1	1
2200	1	21	1	-	3	550001662	2	550001663	WA-4	SA-4	41200069	2200 550001695	1	1
2300	1	22	1	-	2	550001662	3	550001663	WA-4	SA-4	41200069	2300 550001696	1	1
2400	1	23	1	-	1	550001662	4	550001663	WA-4	SA-5	41200069	2400 550001697	1	1
2500	1	24	1	-	-		5	550001663	WA-4	SA-5	41200069	2500 550001698	1	1
2600	1	25	1	2 550001661	-		4	550001663	WA-4	SA-5	41200070	2600 550001698	1	1
2700	1	26	1	1 550001661	1	550001662	4	550001663	WA-5	SA-5	41200070	2700 550001699	1	1
2800	1	27	1	-	2	550001662	4	550001663	WA-5	SA-5	41200070	2800 550001700	1	1
2900	1	28	1	-	1	550001662	5	550001663	WA-5	SA-5	41200070	2900 550001701	1	1
3000	1	29	1	-	-		6	550001663	WA-5	SA-5	41200070	3000 550001702	1	1

- * SEE PAGE 11 - COMPONENT CARTON PARTS LIST
- ** SEE PAGE 10 - WATER TRIM CARTON PARTS LIST
- *** SEE PAGE 10 - STEAM TRIM CARTON PARTS LIST
- + SEE PAGES 4-5 - ACCESSORY CARTON PARTS LIST
- ++ SEE PAGE 11 - JACKET END PANEL CARTON PARTS LIST
- +++SEE PAGE 6 - BASE END PANEL CARTON PARTS LIST

ACCESSORY CARTON

ACCESSORY CARTON														
PARTS DESCRIPTION	PART NO.	BOILER MODEL NUMBERS AND QUANTITIES												
		300	400	500	600	700	800	900	1000	1100	1200	1300	1400	1500
COMPLETE ACCY CRTN #		550001676	550001677	550001679	550001680	550001681	550001682	550001683	550001684	550001684	550001685	550001686	550001687	550001688
4" Push Nipples	43300977	6	8	10	12	14	16	18	20	22	24	26	28	30
5/8" - 11NC x 7 Stud	14695304	6	8	10	12	14	16	18	20	22	24	26	28	30
5/8" - 11NC Hex Nut	1330005	12	16	20	24	28	32	36	40	44	48	52	56	60
5/8" Flat Washer	14695306	12	16	20	24	28	32	36	40	44	48	52	56	60
Furnace Cement - Pint	1440001	2	2	2	2	2	2	2	2	2	2	2	2	2
FB-1 Fitting Bag	41200051	1	1	1	-	-	-	-	-	-	-	-	-	-
FB-2 Fitting Bag	41200052	-	-	-	1	1	1	1	1	-	-	-	-	-
FB-3 Fitting Bag	41200053	-	-	-	-	-	-	-	-	1	1	1	1	1
FB-4 Fitting Bag	41200054	-	-	-	-	-	-	-	-	-	-	-	-	-
FB-5 Fitting Bag	41200055	-	-	-	-	-	-	-	-	-	-	-	-	-
FB-6 Fitting Bag	41200056	-	-	-	-	-	-	-	-	-	-	-	-	-
User's Information Manual	240006925X	1	1	1	1	1	1	1	1	1	1	1	1	1
Installation Instructions	240006636X	1	1	1	1	1	1	1	1	1	1	1	1	1
3/4" Drain Valve	14622001	1	1	1	1	1	1	1	1	1	1	1	1	1
Nipple Paste - 4oz.	14691302	1	1	1	1	1	1	1	1	1	1	1	1	1
Switch High Pressure Gas	1500001	-	-	-	-	-	-	-	-	-	-	-	-	-
1" Sq. Head Plugs	1395004	4	4	4	4	4	4	4	4	4	4	4	4	4
Junction Box Assembly 1-3 Base	550001804	1	1	1	1	1	1	1	1	1	1	1	1	1
Junction Box Assembly 4,5,6 Base	550001806	-	-	-	-	-	-	-	-	-	-	-	-	-
250VA Transformer	550001803	-	-	-	-	-	-	-	-	-	-	-	-	-
Hercules Gripp 1/4 Pint	14691302	1	1	1	1	1	1	1	2	2	2	2	2	2

ACCESSORY CARTON

ACCESSORY CARTON - continued														
BOILER MODEL NUMBERS AND QUANTITIES - continued														
1600	1700	1800	1900	2000	2100	2200	2300	2400	2500	2600	2700	2800	2900	3000
550001689	550001690	550001691	550001692	550001693	550001694	550001695	550001696	550001697	550001698	550001699	550001700	550001701	550001702	550001703
32	34	36	38	40	42	44	46	48	50	52	54	56	58	60
32	34	36	38	40	42	44	46	48	50	52	54	56	58	60
64	68	72	76	80	84	88	92	96	100	104	108	112	116	120
64	68	72	76	80	84	88	92	96	100	104	108	112	116	120
2	2	4	4	4	4	4	4	4	4	4	4	4	4	4
-	-	-	-	-	-	-	-	-	-	-	-	-	-	-
-	-	-	-	-	-	-	-	-	-	-	-	-	-	-
-	-	-	-	-	-	-	-	-	-	-	-	-	-	-
1	1	1	1	1	-	-	-	-	-	-	-	-	-	-
-	-	-	-	-	1	1	1	1	1					
-	-	-	-	-	-	-	-	-	-	1	1	1	1	1
1	1	1	1	1	1	1	1	1	1	1	1	1	1	1
1	1	1	1	1	1	1	1	1	1	1	1	1	1	1
1	1	1	1	1	1	1	1	1	1	1	1	1	1	1
1	1	1	1	1	1	1	1	1	1	1	1	1	1	1
-	-	-	-	-	-	-	-	-	-	1	1	1	1	1
4	4	4	4	4	4	4	4	4	4	4	4	4	4	4
-	-	-	-	-	-	-	-	-	-	-	-	-	-	-
1	1	1	1	1	1	1	1	1	1	1	1	1	1	1
1	1	1	1	1	1	1	1	1	1	1	1	1	1	1
2	2	2	2	3	3	3	3	3	3	3	3	3	3	3

BASE MATERIAL LIST

Base Assembly

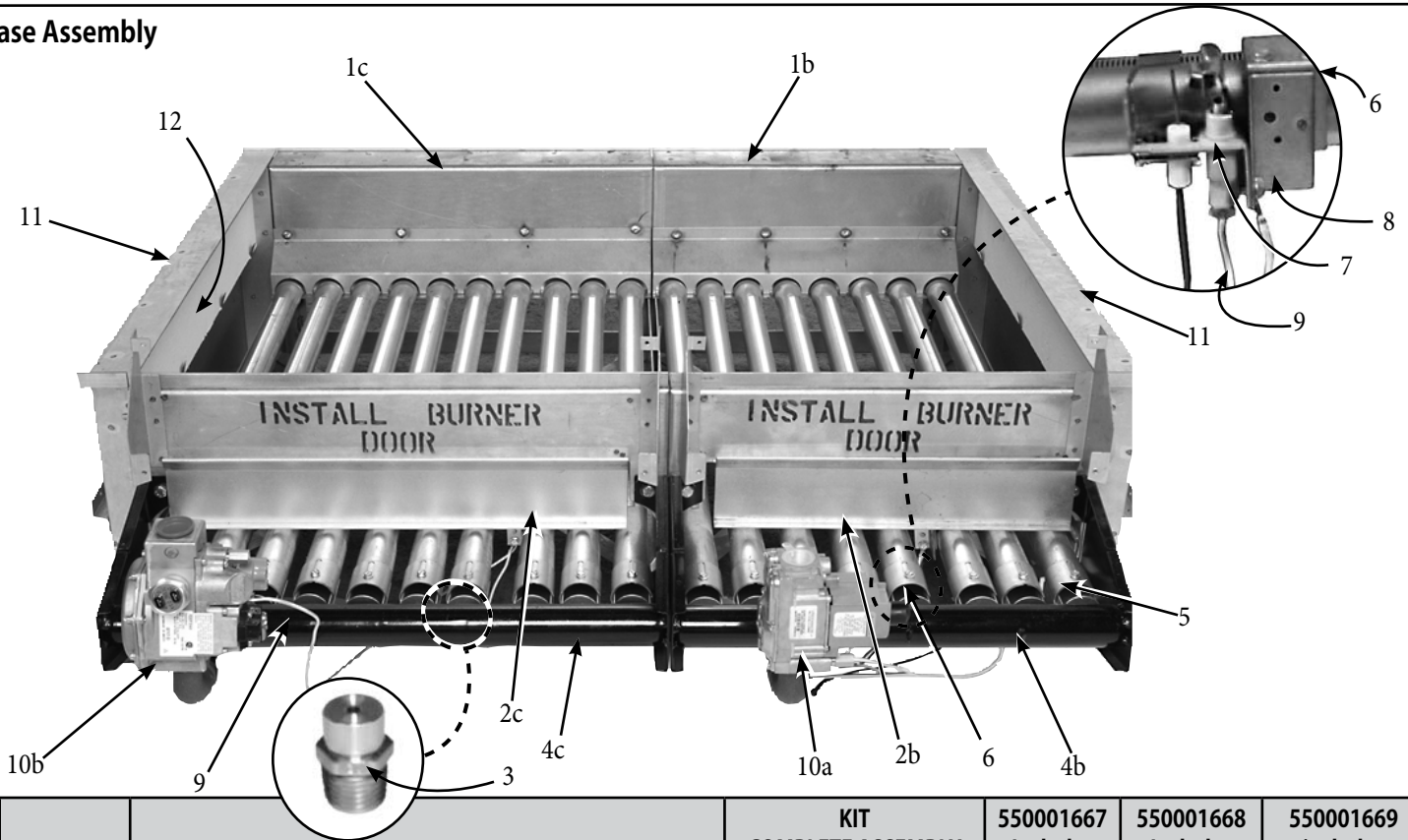

No.	PARTS DESCRIPTION	KIT COMPLETE ASSEMBLY	550001667 Includes	550001668 Includes	550001669 includes
		MODEL	300	400	500
		PART NO.	QTY.	QTY.	QTY.
1a	300 Base (Not Shown)	42557123	1	-	-
1b	400 Base	42557124	-	1	-
1c	500 Base	42557125	-	-	1
2a	300 Fire Door (Not Shown)	42557133	1	-	-
2b	400 Fire Door	42557134	-	1	-
2c	500 Fire Door	42557135	-	-	1
3	Orifice #30 (In Manifold)	14615310	6	8	10
4a	300 Manifold (Not Shown)	240006633	1	-	-
4b	400 Manifold	240006634	-	1	-
4c	500 Manifold	240006635	-	-	1
5	Main Burner	14615302	5	7	9
6	Main Burner with Pilot Bracket	14615301	1	1	1
7	Pilot with Ignition Wire	14662099	1	1	1
8	Pilot Mounting Bracket	42557029	1	1	1
9	Pilot Tubing	14615005	1	1	1
10a	VR8304M Gas Valve (300 & 400 Base)	14662315	1	1	-
10b	7000 DERHC Gas Valve (500 Base)	14663001	-	-	1
11	Base End Panels (Left & Right) - Not available individually	42557119	1		
12	Base Side Insulation, Right & Left	13702230	2		
13	Front Base Insulation- 1x3x12.25" (not shown)	420001043	1		
14	Front Base Insulation- 1x3x16.50" (not shown)	420001044		1	
15	Front Base Insulation- 1x3x20.75" (not shown)	420001045			1

MATERIAL LISTS

Control Assembly

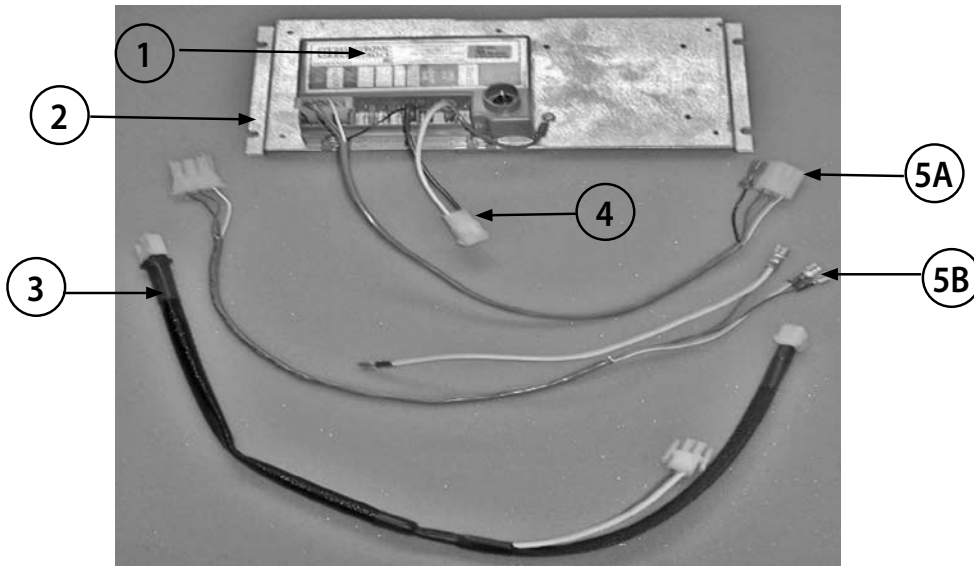

CONTROL ASSEMBLY

		Control Panel Assembly 300 & 400 Base	Control Panel Assembly 500 Base	
COMPLETE CONTROL PANEL ASSEMBLY		550001801	550001802	
NO.	PARTS DESCRIPTION	PART NO.	PART NO.	QUANTITY
1	Intermittent Pilot Module	14662070	14662070	1
2	Control Mounting Panel	109006832	109006832	1
3	Base Power Harness	240006732	240006732	1
4	Spark Control Harness	240006625	240006625	1
5A	Harness Gas Valve	240006624		1
5B	Harness Gas Valve		240006841	1

250VA Transformer Assembly

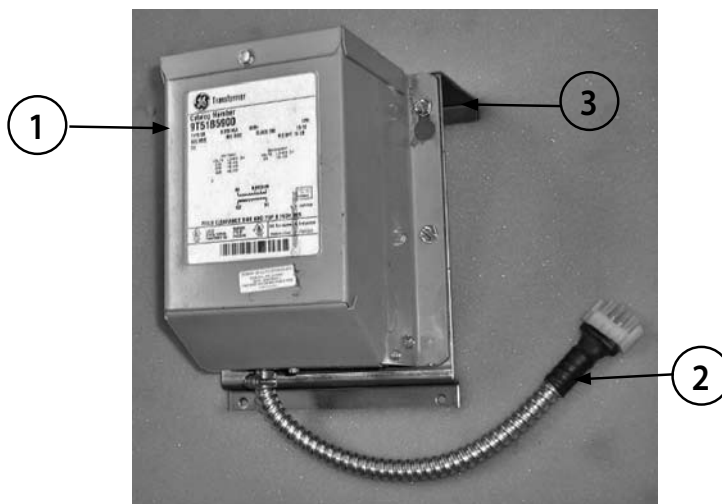

250VA TRANSFORMER ASSEMBLY

COMPLETE TRANSFORMER ASSEMBLY			MODELS 1600-3000
550001803			
NO.	PARTS DESCRIPTION	PART NO.	Quantity
1	Transformer	1551005	1
2	Harness	240006696	1
3	Mounting Bracket	109006825	1

MATERIAL LISTS

JUNCTION BOX ASSEMBLY 550001804

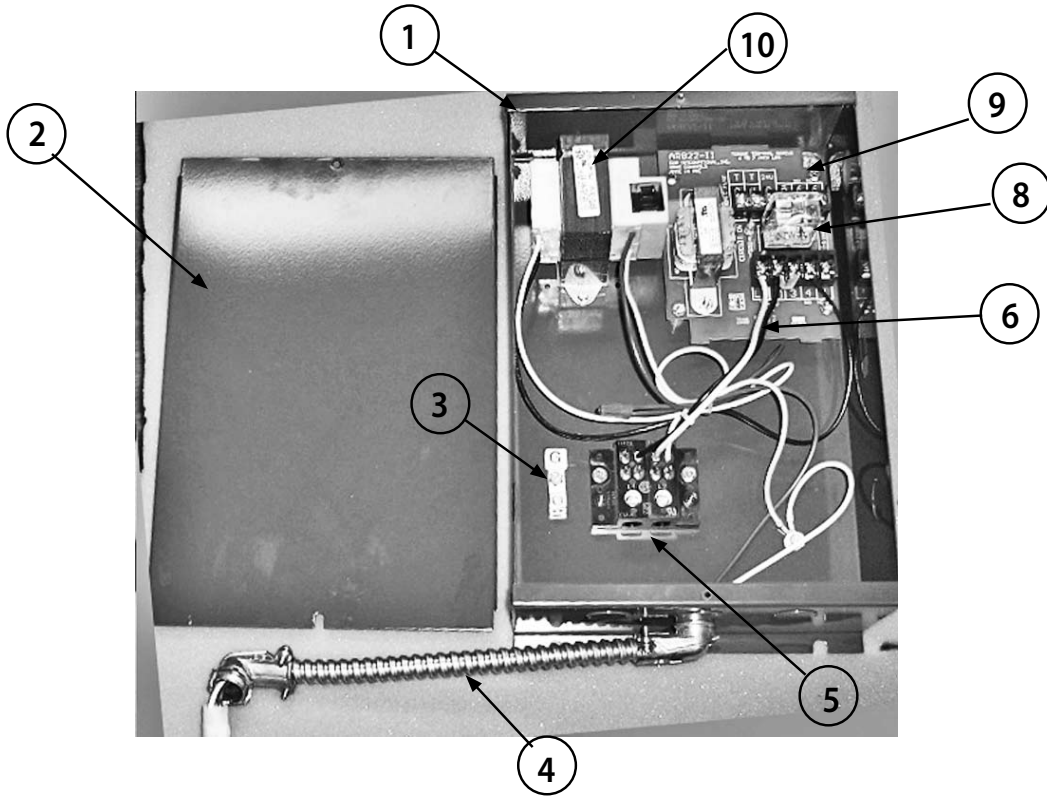

JUNCTION BOX ASSEMBLY 550001806

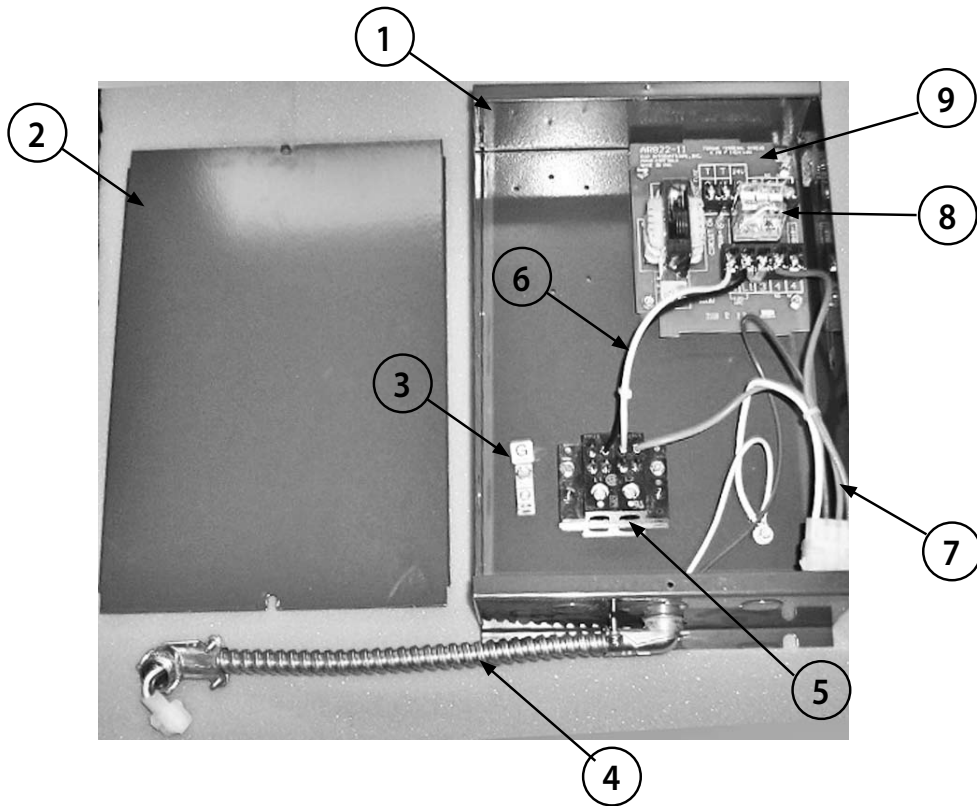

MATERIAL LISTS

JUNCTION BOX ASSEMBLY				
			MODELS 300-1500	MODELS 1600-3000
COMPLETE JUNCTION BOX ASSEMBLY 1-3 BASE - 550001804			1	-
COMPLETE JUNCTION BOX ASSEMBLY 4-6 BASE - 550001806			-	1
NO.	PARTS DESCRIPTION	PART NO.	QTY.	QTY.
1	Junction Box	109006843	1	1
2	Box Cover	109006844	1	1
3	Ground Lug	212000015	1	1
4	Harness, Main Burner	240006699	1	1
5	Terminal Block	212000014	1	1
6	Harness, Relay Power	240006697	1	1
7	Harness, Transformer	240006698	-	1
8	AR822II Control Board	240006685	1	1
9	Relay on AR822II	R35C	1	1
10	Transformer 75VA	240006995	1	-

MATERIAL LISTS

WATER TRIM CARTON MATERIAL LIST							
PARTS DESCRIPTION	PART NO.	UNIT	QUANTITY PER CARTON				
			WA-1	WA-2	WA-3	WA-4	WA-5
			41200071	41200072	41200073	41200074	41200075
L4006A Aquastat	240006706	Ea.	1	1	1	1	1
Well for Aquastat	14662804	Ea.	1	1	1	1	1
Water Temperature/Pressure Gauge	1260006	Ea.	1	1	1	1	1
1/2" x 1/4" Bushing	1060001	Ea.	1	1	1	1	1
3/4" x 3/4" Relief Valve	14622011	Ea.	1	-	-	-	-
3/4" x 1" Relief Valve	14622311	Ea.	-	1	-	-	-
1" x 1.1/4" Relief Valve	14622312	Ea.	-	-	1	-	-
1.1/4" x 1.1/2" Relief Valve	14622313	Ea.	-	-	-	1	-
1.1/2" x 2" Relief Valve	1570028	Ea.	-	-	-	-	1

STEAM TRIM CARTON							
PARTS DESCRIPTION	PART NO.	UNIT	QUANTITY PER CARTON				
			SA-1	SA-2	SA-3	SA-4	SA-5
			41200061	41200062	41200063	41200064	41200065
67D-1 McDonnell & Miller LWCO	14626042	Ea.	1	1	1	1	1
PA404A Pressuretrol	14662015	Ea.	1	1	1	1	1
Gauge-water level 22-182-10 8.1/16" Tube	GA-004.00	Ea.	1	1	1	1	1
2.1/2" Round Steam Gage	14623006	Ea.	1	1	1	1	1
3/4" x 3/4" Pop Safety Valve	1570001	Ea.	1	-	-	-	-
1" x 1" Pop Safety Valve	1570002	Ea.	-	1	-	-	-
1.1/4" x 1.1/2" Pop Safety Valve	1570003	Ea.	-	-	1	-	-
1.1/2" x 2" Pop Safety Valve	1570004	Ea.	-	-	-	1	-
2" x 2" Pop Safety Valve	1570005	Ea.	-	-	-	-	1
1/4" Brass Syphon Loop	14643005	Ea.	1	1	1	1	1
1/4" Brass Tee	14693057	Ea.	1	1	1	1	1
1/4" x 2" Brass TBE Nipple	14607054	Ea.	1	1	1	1	1

MATERIAL LISTS

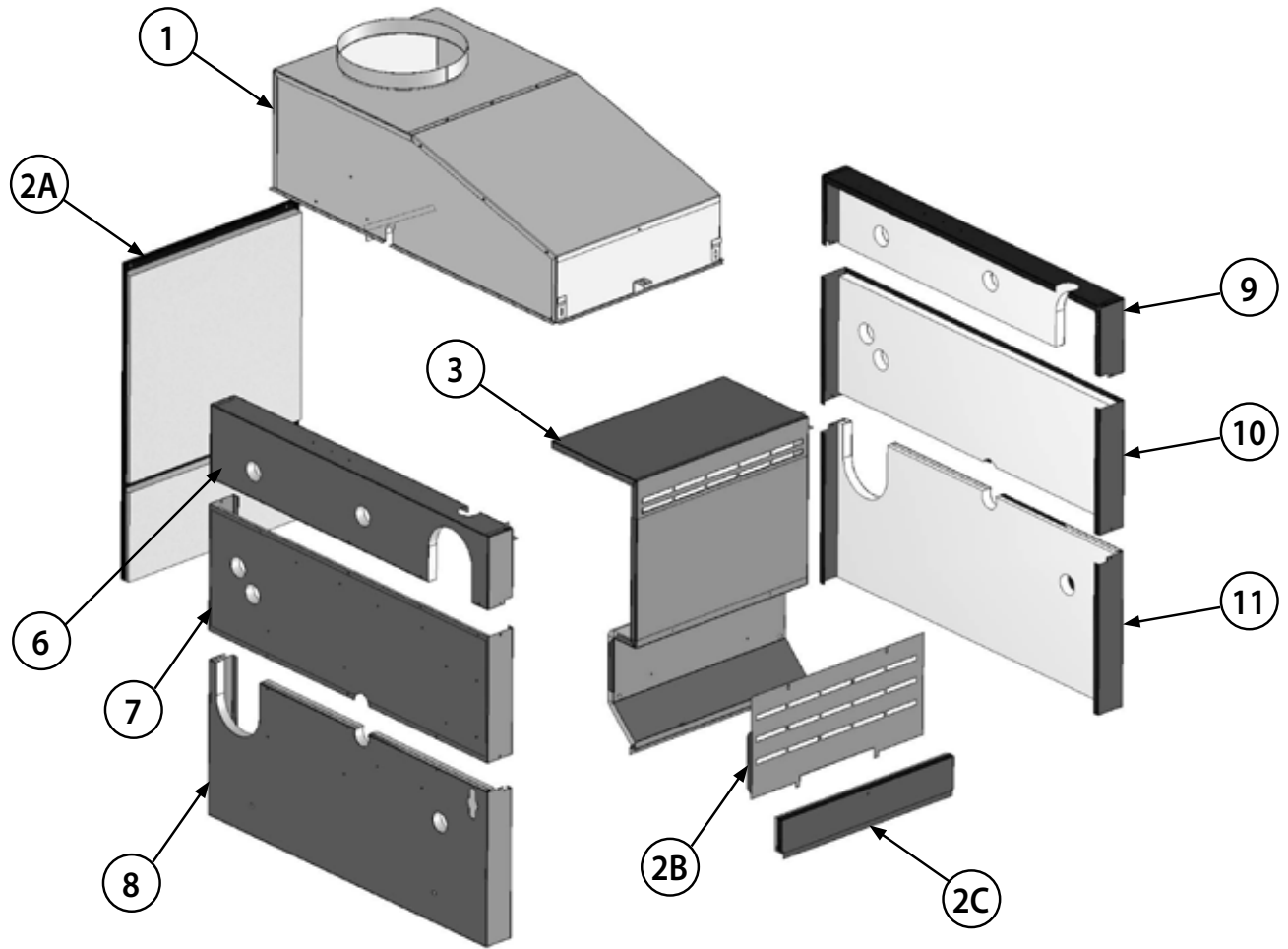

COMPONENT CARTON MATERIAL LIST				
ITEM	PARTS DESCRIPTION	Model 300 550001661	Model 400 550001662	Model 500 550001663
1	Draft Hood	42557113	42557114	42557115
2	Intermediate Jacket Carton	550001673	550001674	550001675
2A	Rear Panel	42557039AC	42557040AC	42557041AC
2B	Control Panel Access Door	109006756AC	109006757AC	109006758AC
2C	Lower Access Door	109006759AC	109006760AC	109006761AC
3	Top Front Panel Assembly	109006881	109006882	109006883
4	Base Assembly (see pg 3)	550001667	550001668	550001669
5	Control Panel Assembly (not shown)	550001801	550001801	550001802
JACKET END PANEL CARTON (550001876) MATERIAL LIST				
6	Panel End Left Upper	109007170		
7	Panel End Left Middle	109007171		
8	Panel End Left Lower	109007172		
9	Panel End Right Upper	109007173		
10	Panel End Right Middle	109007174		
11	Panel End Right Lower	109007175		

MATERIAL LISTS

FITTING BAGS MATERIAL LIST							
PARTS DESCRIPTION	PART NO.	FB-1	FB-2	FB-3	FB-4	FB-5	FB-6
		41200051	41200052	41200053	41200054	41200055	41200056
#10 x 1/2" Self Tap Screws	14695074	60	70	80	90	100	120
#8 x 3/4" Self Tap Screws	14695003	2	2	2	2	2	2
5/16" - 18NC 3/4" Hex Head Bolts	1040001	8	12	16	20	24	28
5/16" - 18NC Hex Nuts	1330007	8	12	16	20	24	28
1/4" - 20NC x 1.1/2" J Bolts	14695303	1	2	3	4	5	6
1/4" - 20NC Hex Bolts	HW-003.02	1	2	3	4	5	6
Jacket Door Knobs	13702153	1	2	3	4	5	6
Knob Screws	14695004	1	2	3	4	5	6

ALTERNATE COMPONENT LIST		
NO.	PARTS DESCRIPTION	PART NO.
1	Steam Manual Reset Pressure Control (L404C-1147)	14662311
2	LWCO and Feeder #47-2 (Models 300-1500)	1280001
3	Water High Limit Control with Manual Reset - (L4006E-1109 and well)	43300520
4	Strap-on Operating Control (L6006C-1034)	14662313
5	LWCO with Manual Reset (PS852M-24) - to eliminate the 67D LWCO	14626305
6	50 PSI Relief Valve (in place of 30 PSI)	14622315
7	ARGO AMB-4 Modular Boiler Control Kit - To allow stage firing of up to 4 bases (Water Boilers Only). Includes outdoor reset, priority override and lead boiler rotation. (Refer to AMB manual for parts list)	550001730X*
8	ARGO AMB-8 Modular Boiler Control Kit - To allow stage firing of up to 8 bases (Water Boilers Only). Includes outdoor reset, priority override and lead boiler rotation. (Refer to AMB manual for parts list)	550001731X*
9	CSD-1 Gas Train (Refer to CSD-1 manual for parts list)	---

* X = U For JD Series
D For D248 Series
P For 41J Series