

Q90 125-200 GAS-FIRED DIRECT VENT CONDENSING HOT WATER BOILER



DUNKIRK BOILERS
85 Middle Rd.
Dunkirk, NY 14048
www.dunkirk.com
MEMBER: Hydronics Institute



INSTALLATION MANUAL AND OPERATING INSTRUCTIONS

TABLE OF CONTENTS

I. Introduction..... 2
 II. Safety Symbols..... 2
 III. Rules For Safe Installation and Operation..... 3
 IV. Boiler Ratings and Capacities 4
 V. Before Installing The Boiler 5
 VI. Placing The Boiler 9
 VII. Near Boiler Piping 10
 VIII. Combustion Air and Vent Pipe 13
 IX. Gas Supply Piping..... 15
 X. Electrical Wiring 16
 XI. Controls and Accessories..... 20
 XII. Startup..... 22
 XIII. Checkout Procedures and Adjustments 26
 XIV. Maintenance and Cleaning 29
 XV. Detailed Sequence of Operation 31
 XVI. Troubleshooting 34
 XVII. Installation and Checkout Certificate 43

**KEEP THIS MANUAL NEAR BOILER AND
 RETAIN FOR FUTURE REFERENCE.**

I. INTRODUCTION

This appliance is a gas-fired direct vent cast aluminum hot water boiler. A revolutionary cast aluminum heat exchanger means better heat transfer and thermal storage than similarly sized cast iron boilers, which results in higher efficiency. The heating system water absorbs large amounts of heat from the cast aluminum heat exchanger, cooling the flue gases and causing condensation. Sealed combustion, premix gas burner, and low flame temperature means drastically reduced CO and NOx emissions, which contribute to a cleaner and healthier environment.

This appliance, unlike normal residential atmospheric and induced draft units, takes its combustion air directly from the outdoors (sealed combustion) and does not compete with building occupants for fresh air. Sealed combustion (also known as “direct vent”) is the safest and best way to obtain plenty of clean combustion air.

The forced draft fan draws in the outside combustion air to mix with gas, which flows into the pre-mix burner and combusts. The fan then forces the resulting flue gases from the boiler unit and provides a positive removal of the flue gases from the building through inexpensive and readily available PVC and CPVC vent pipes.

II. SAFETY SYMBOLS

The following defined symbols are used throughout this manual to notify the reader of potential hazards of varying risk levels.



DANGER

Indicates an *imminently* hazardous situation which, if not avoided, *will* result in death, serious injury or substantial property damage.



WARNING

Indicates a *potentially* hazardous situation which, if not avoided, *could* result in death, serious injury or substantial property damage.



CAUTION

Indicates a *potentially* hazardous situation which, if not avoided, could result in minor or moderate injury or property damage.

IMPORTANT: Read the following instructions **COMPLETELY** before installing!



III. RULES FOR SAFE INSTALLATION AND OPERATION

⚠ WARNING

This appliance has been equipped for residential installations. If used for commercial applications, any and all additional code requirements must be adhered to for installation. This may require additional controls, including but not limited to a manual reset low water cut off, a manual reset high temperature limit, and wiring and/or piping modifications.

The manufacturer is not responsible for any field installation changes made to a boiler installation WHICH ARE NOT DESCRIBED OR ACKNOWLEDGED IN THIS MANUAL.

Figure #1

BOILER JACKETS

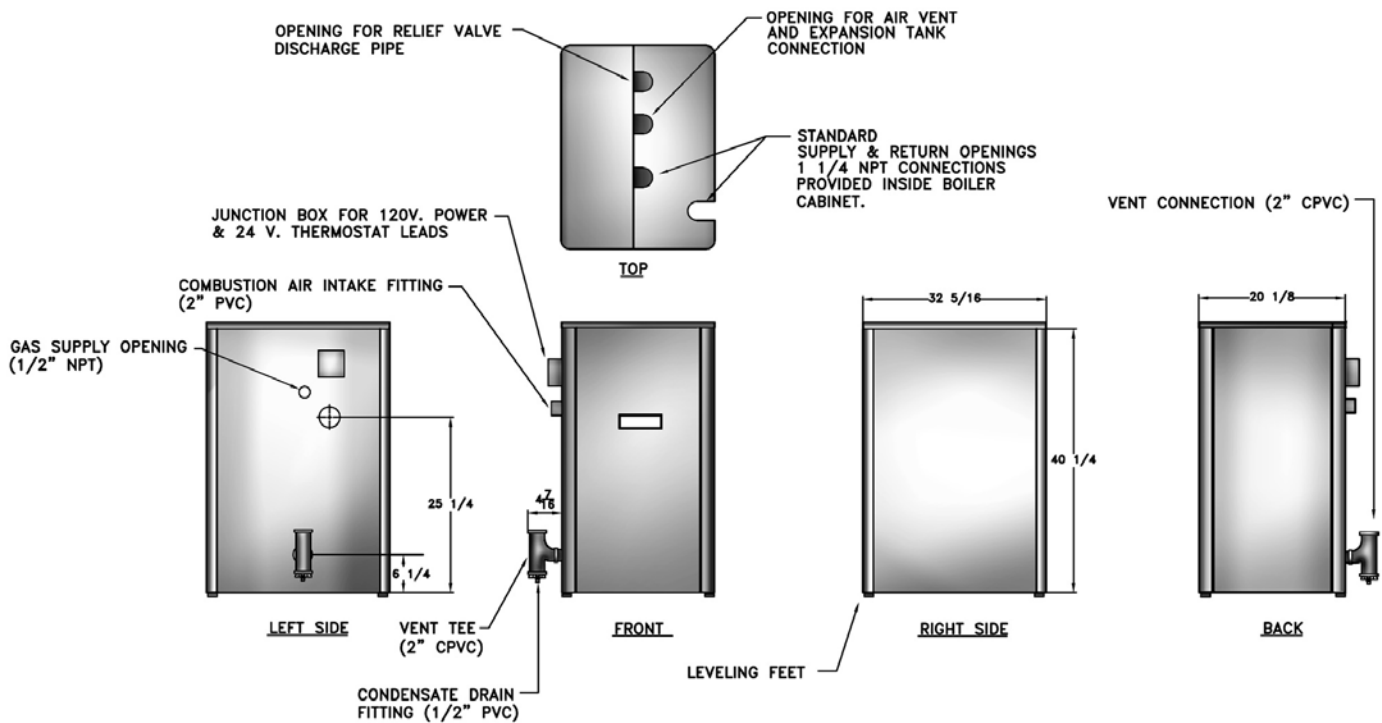

IMPORTANT:

Failure to follow these instructions could cause a malfunction of the boiler and result in death, serious bodily injury, and/or property damage.

For assistance or additional information, consult a qualified installer, service agency, or the gas supplier.

1. Check all applicable state and local building codes and utility company requirements before installation. This installation must conform with these requirements in their entirety. In the absence of these codes, use NFPA installation codes and good industry practice.
2. Before servicing the boiler, allow it to cool. Always shut off any electricity and gas supply connected to the boiler prior to servicing.
3. Inspect gas line for leaks.
4. Be certain gas input rate is correct. Overfiring may result in early failure of the boiler components. This may cause dangerous operation. Underfiring may result in too much air for the pre-mix burner causing poor or loss of combustion.
5. Never vent the products of combustion from this boiler to an enclosed space. Always vent to the outdoors. Never vent to another room or to inside a building.
6. Be sure there is adequate outdoor air supply to boiler for complete combustion.

III. RULES FOR SAFE INSTALLATION AND OPERATION

7. Follow a regular service and maintenance schedule for efficient and safe operation.
8. Keep boiler area clean of debris and free of combustible and flammable materials.
9. Proper through-the-wall or through-the-roof combustion venting shall be in accordance with the materials and methods described in this manual. Installation must comply with local codes.
10. This boiler and related hot water heating systems are not do-it-yourself items. They must be installed and serviced by qualified professionals.

IV. BOILER RATINGS & CAPACITIES

TABLE #1 - SEA LEVEL RATINGS (NATURAL AND PROPANE GASES)

Model	Input (MBH) ⁽¹⁾	Heating Capacity (MBH) ⁽¹⁾⁽²⁾	Net I=B=R Rating (MBH) ⁽¹⁾	Shipping Weight (lbs.)	AFUE ⁽²⁾	Flue Diameter
125	125	112.5	98	284	90	2" CPVC & 3" PVC
150	150	135	117	284	90	2" CPVC & 3" PVC
175	175	157.5	137	284	90	2" CPVC & 3" PVC
200	200	180	157	284	90	2" CPVC & 3" PVC

⁽¹⁾ 1 MBH = 1,000 Btuh (British Thermal Units Per Hour)

⁽²⁾ AFUE (Annual Fuel Utilization Efficiency) and Heating Capacity is based on Department of Energy test procedure.

Ratings shown are for sea level applications. The boiler automatically derates input as altitude increases. No alterations to boiler are required for altitudes above sea level.

TABLE #2 - NATURAL GAS

Nominal Input	200,000		175,000		150,000		125,000	
	Vent Lengths		Vent Lengths		Vent Lengths		Vent Lengths	
Altitude	Min	Max	Min.	Max	Min.	Max	Min.	Max
0	200,000	200,000	175,000	175,000	150,000	150,000	125,000	125,000
1,000	197,000	196,500	172,400	172,200	147,800	147,400	123,500	123,000
2,000	194,000	193,000	169,800	169,400	145,600	144,800	122,000	121,000
3,000	191,000	189,500	167,200	166,600	143,400	142,200	120,500	119,000
4,000	188,000	186,000	164,600	163,800	141,200	139,600	119,000	117,000
5,000	185,000	182,500	162,000	161,000	139,000	137,000	117,500	115,000
6,000	182,000	179,000	159,400	158,200	136,800	134,400	116,000	113,000
7,000	179,000	175,500	156,800	155,400	134,600	131,800	114,500	111,000
8,000	176,000	172,000	154,200	152,600	132,400	129,200	113,000	109,000
9,000	173,000	168,500	151,600	149,800	130,200	126,600	111,500	107,000
10,000	170,000	165,000	149,000	147,000	128,000	124,000	110,000	105,000

IV. BOILER RATINGS & CAPACITIES

TABLE #3 - LP GAS

Nominal Input	200,000		175,000		150,000		125,000	
	Vent Lengths		Vent Lengths		Vent Lengths		Vent Lengths	
Altitude	Min.	Max	Min.	Max	Min.	Max	Min.	Max
0	200,000	200,000	175,000	175,000	150,000	150,000	125,000	125,000
1,000	195,900	195,750	171,900	171,200	146,900	146,700	123,050	122,250
2,000	191,800	191,500	168,800	167,400	143,800	143,400	121,100	119,500
3,000	187,700	187,250	165,700	163,600	140,700	140,100	119,150	116,750
4,000	183,600	183,000	162,600	159,800	137,600	136,800	117,200	114,000
5,000	179,500	178,750	159,500	156,000	134,500	133,500	115,250	111,250
6,000	175,400	174,500	156,400	152,200	131,400	130,200	113,300	108,500
7,000	171,300	170,250	153,300	148,400	128,300	126,900	111,350	105,750
8,000	167,200	166,000	150,200	144,600	125,200	123,600	109,400	103,000
9,000	163,100	161,750	147,100	140,800	122,100	120,300	107,450	100,250
10,000	159,000	157,500	144,000	137,000	119,000	117,000	105,500	97,500

These low pressure gas-fired hot water boilers are design certified by CSA International, for use with natural and propane gases. The boilers are constructed and hydrostatically tested for a maximum working pressure of 50 psig (pounds per square inch gauge) in accordance with A.S.M.E. (American Society of Mechanical Engineers) Boiler and Pressure Vessel Code, Section IV Standards for heating boilers.

The Boilers are certified in accordance with ANSI (American National Standards Institute) Z21.13 standards as gas-fired, direct vent, condensing, hot water boilers.

The **Heating Capacity** indicates the amount of heat available after subtracting the losses up the stack. Most of this heat is available to heat water. A small portion is heat loss from the jacket and surfaces of the boiler, and it is assumed that this heat stays in

the structure. The **Net I=B=R Rating** represents the portion of the remaining heat that can be applied to heat the radiation or terminal units (i.e. Finned tube baseboard, cast iron radiators, radiant floor, etc.). The difference between the Heating Capacity and the Net I=B=R Rating, called the piping and pickup allowance, establishes a reserve for heating the volume of water in the system and offsetting heat losses from the piping. The Net I=B=R Ratings shown are based on a piping and pickup factor of 1.15 in accordance with the I=B=R Standard as published by the Hydronics Institute. The Net I=B=R Rating of the boiler selected should be greater than or equal to the calculated peak heating load (heat loss) for the building or area(s) served by the boiler and associated hot water heating systems. The manufacturer should be consulted before selecting a boiler for installations having unusual piping and pickup requirements.

V. BEFORE INSTALLING THE BOILER

Complete all of the following prior to installing the boiler.

CODES

This boiler product is a gas-fired, direct vent, condensing boiler and must be installed in accordance with all applicable federal, state and local building codes including, but not limited to the following:

United States - Installation shall conform with National Fuel Gas Code (NFPA-54/ANSI Z223.1 - latest revision)

Canada - Installation shall be in accordance with CSA-B149.1 and .2 installation codes.

Where required by the authority having jurisdiction, the installation must conform to the American Society of Mechanical Engineers Safety Code for Controls and Safety Devices for Automatically Fired Boilers, No.CSD-1.

V. BEFORE INSTALLING THE BOILER

The installation must conform to the requirements of the authority having jurisdiction or, in the absence of such requirements, to the National Fuel Gas Code, ANSI Z223.1 - latest revision.

In the State of Massachusetts:

- This product must be installed by a licensed plumber or gas fitter.
- When flexible connectors are used, the maximum length shall not exceed 36 inches.
- When lever type gas shut-offs are used, they shall be T-handle type.

Installers - Follow local regulations with respect to installation of CO (Carbon Monoxide) Detectors. Follow maintenance recommendations in this manual.

BOILER SIZING

- Check to be sure you have selected the boiler with the proper capacity before continuing the installation. The I=B=R Rating of the boiler selected should be greater than or equal to the calculated peak heating load (heat loss) for the building or area(s) served by the boiler and associated hot water heating systems. See Section IV, "Boiler Ratings and Capacities," for more information.
- Heat loss calculations should be based on approved industry methods.

CONSIDERATIONS FOR BOILER LOCATION

Before selecting a location for the boiler, the following should be considered. Each boiler considered for installation must be:

- Supplied with the correct type of gas (*natural gas or propane*).
- Connected to a suitable combustion air intake piping system to supply the correct amounts of fresh (*outdoor*) air for combustion (*max. length 60'*).
- Connected to a suitable venting system to remove the hazardous products of gas combustion (*max. length 60'*).
- Connected to a suitable hot water heating system.
- Supplied with a suitable electrical supply for all boiler motors and controls.
- Connected to a properly located thermostat or operating control. (Not included with boiler)
- Placed on level surface (must **NOT** be installed on carpeting)
- Condensate drain line must be pitched down to floor drain or external condensate pump with reservoir at 1/4" per foot (wood frame or blocks may be used to raise boiler).

LOCATING THE BOILER

1. Select a location which is level, central to the piping systems served and as close to the vent and air intake terminals as possible.
2. Accessibility clearances, if more stringent (i.e. larger clearances) than required fire protection clearances, must be used for the boiler installation. Accessibility clearances may be achieved with the use of removable walls or partitions.
3. The boiler is approved for installation in closets and on combustible floors. This boiler shall **NOT** be installed on carpeting.

TABLE #4 - BOILER CLEARANCES

Unit	Combustible Clearance	Accessibility, Cleaning, and Servicing
Top	1"	8"
Left Side	8"	24"
Right Side	1"	-
Base	1"	-
Front	0"	24"
Back	1"	-
Intake/Vent Piping	0"	-
Near Boiler Hot Water Piping	1"	-

All distances measured from the cabinet of the boiler.

4. The clearances shown in Table 4 indicate required clearances per CSA listing. A min.. 1" clearance must be maintained between combustible construction and each of the right, top and back surfaces of the boiler. A min.. 8" clearance is required on the left side, to allow room for the inlet air pipe. An 18" clearance must be maintained at the front where passage is required for cleaning or servicing, inspection or replacement of any parts that normally may require such attention. Allow at least 24" at the front and left side and 8" at the top for servicing. No combustible clearances are required to venting or combustion air intake piping.

CAUTION

Keep boiler area clean of debris and free of flammable and combustible materials, liquids and vapors.

V. BEFORE INSTALLING THE BOILER

- Equipment shall be installed in a location which facilitates the operation of venting and combustion air intake piping systems as described in this manual.
- Advise owner of boiler to keep venting and combustion air intake passages free of obstructions. Both the venting and combustion air intake piping systems connected to the outdoors must permit flow through the piping systems without restrictions for the boiler to operate.
- The boiler shall be installed such that the automatic gas ignition system components are protected from water (dripping, spraying, rain, etc.) during operation and service (circulator replacement, control replacement, etc.).
- The boiler must be located where ambient temperatures (minimum possible room temperatures where boiler is installed assuming boiler is not in operation and therefore contributes no heat to the space) are always at or above 32°F to prevent freezing of liquid condensate.

COMBUSTION AIR/VENT PIPE REQUIREMENTS

This boiler requires a dedicated direct vent system. In a direct vent system, all air for combustion is taken directly from outside atmosphere, and all flue products are discharged to outside atmosphere.

Figure #1

ROOF VENT / INTAKE TERMINATIONS

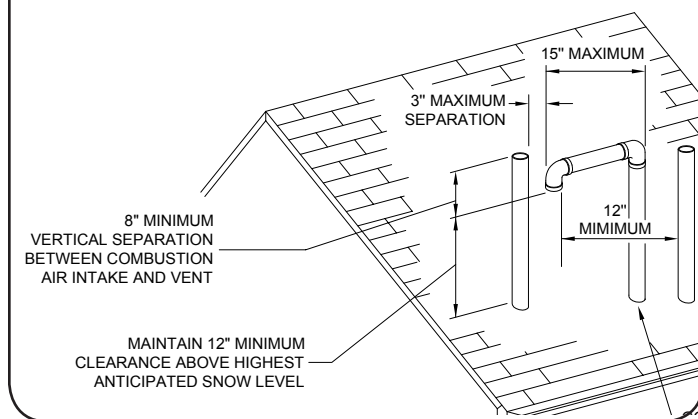

Combustion air and vent pipe connections must terminate together in the same atmospheric pressure zone, either through the roof or sidewall (roof termination preferred). See **Figures #1** and **#2** for required clearances.

Figure #2

SIDEWALL VENT/INTAKE TERMINATIONS

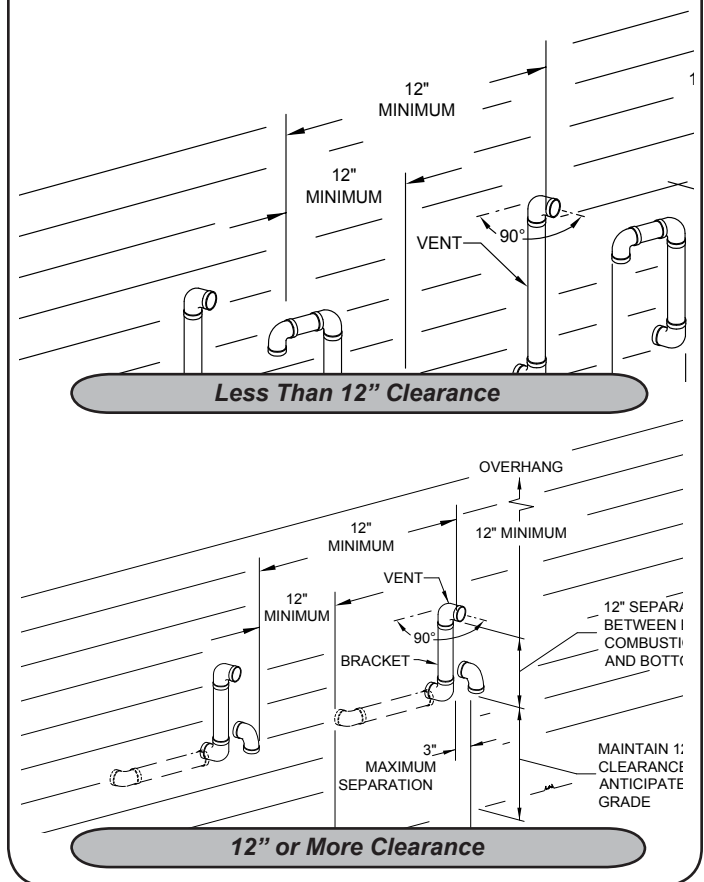

If the concentric vent termination is being used, refer to **Figure #3** for proper setup.

Figure #3

CONCENTRIC VENT TERMINATIONS

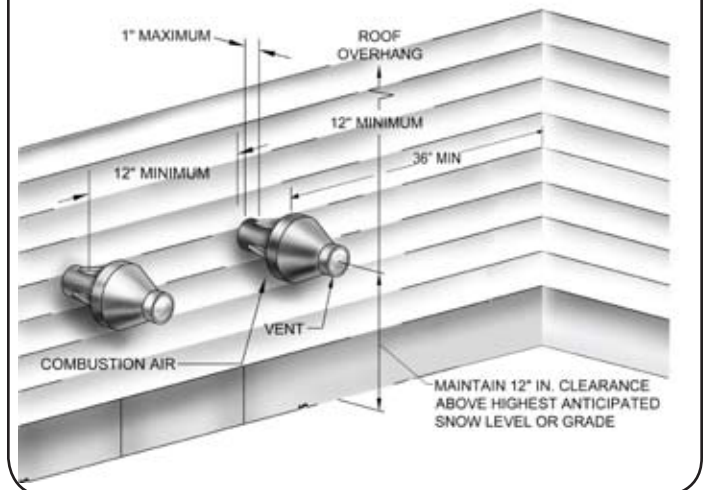

V. BEFORE INSTALLING THE BOILER

COMBUSTION AIR/VENT PIPE REQUIREMENTS *Continued*

WARNING

FAILURE TO FOLLOW THESE WARNINGS COULD RESULT IN FIRE, PROPERTY DAMAGE, PERSONAL INJURY, OR DEATH.

When vent pipe is exposed to temperatures below freezing, such as when it passes through an unheated space or when a chimney is used as a chaseway, vent pipe must be insulated with 1/2" Armaflex or equivalent. In extremely cold climate areas, use 3/4" Armaflex or equivalent.

Combustion air must be clean outdoor air. Combustion air must not be taken from inside the structure because that air is frequently contaminated by halogens, which include fluorides, chlorides, phosphates, bromides and iodides. These elements are found in aerosols, detergents, bleaches, cleaning solvents, salts, air fresheners, paints, adhesives, and other household products.

Locate combustion air inlet as far away as possible from swimming pool and swimming pool pump house. All combustion air and vent pipes must be airtight and watertight. Combustion air and vent piping must also terminate exactly as shown in **Figures #1 – #2**. If a concentric vent termination is being used, refer to **Figures #3 – #5** for proper setup.

Vent connections serving appliances vented by natural draft shall not be connected into any portion of mechanical draft systems operating under positive pressure.

Solvent cements are combustible. Keep away from heat, sparks, or open flame. Use only in well ventilated areas. Avoid breathing in vapor or allowing contact with skin or eyes.

Figure #4

CONCENTRIC VENT

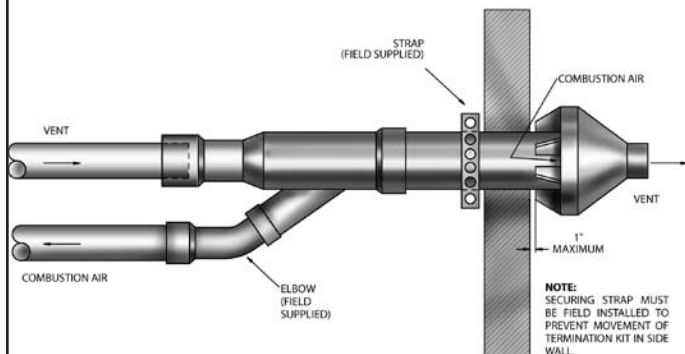
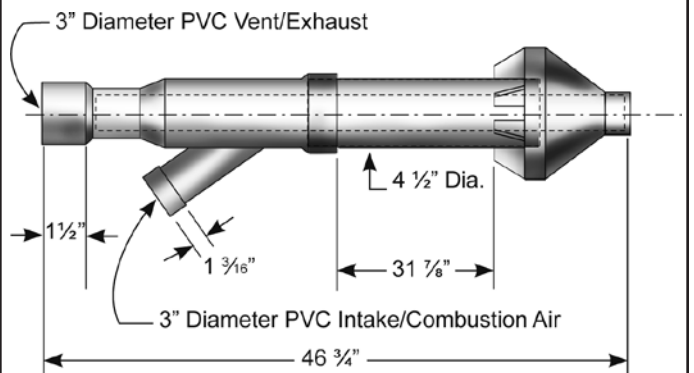
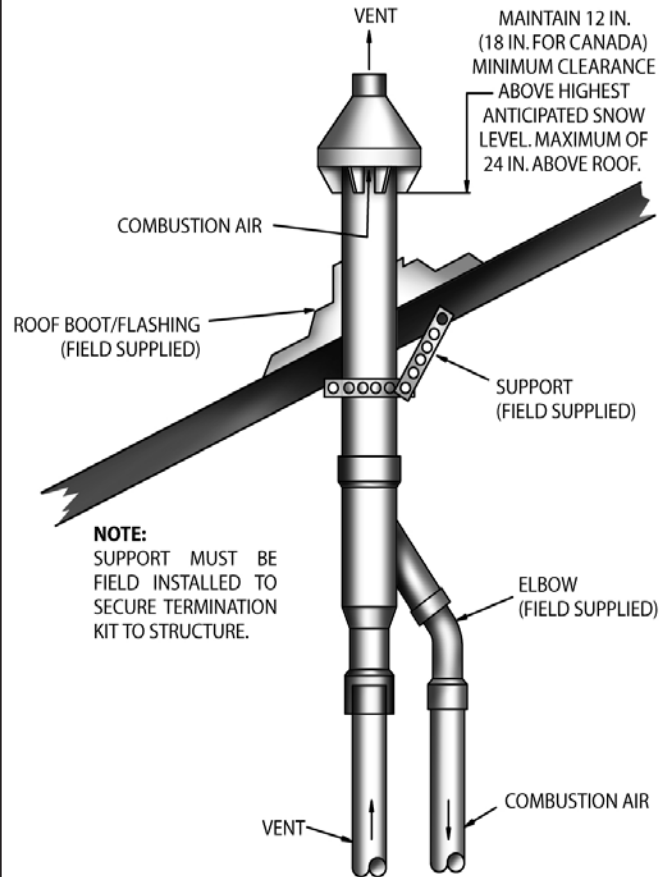

Figure #5

CONCENTRIC VENT ROOF INSTALLATION



V. BEFORE INSTALLING THE BOILER

FOUNDATION REQUIREMENTS

Boiler must be placed on level surface. Boiler is NOT to be installed on carpeting.

NOTES:

1. If boiler is not level condensate drain lines will not function properly. Adjustable feet are located on the boiler to make up for minor surface irregularities or tilt.
2. Wood frame or blocks may be used to raise boiler to maintain drain pitch or to be above external condensate pump reservoir.

REMOVAL OF EXISTING BOILER FROM COMMON VENT SYSTEM

When an existing boiler is removed from a common venting system, the common venting system is likely to be too large for proper venting of the appliances remaining connected to it. At the time of removal of an existing boiler, the following steps shall be followed with each appliance remaining connected to the common venting system placed in operation, while the other appliances remaining connected to the common venting system are not in operation.

1. Seal any unused openings in the common venting system.
2. Visually inspect the venting system for proper size and horizontal pitch and determine there is no blockage or restriction, leakage, corrosion or other deficiencies which could cause an unsafe condition.
3. When it is practical, close all building doors and windows and all doors between the space in which

the appliances remaining connected to the common venting system are located and other spaces of the building. Turn on clothes dryer and any appliance not connected to the common venting system. Turn on any exhaust fans, such as range hoods and bathroom exhaust, so they will operate at maximum speed. Do not operate a summer exhaust fan. Close fire dampers.

4. Place in operation the appliance being inspected. Follow the lighting instructions. Adjust thermostat so appliances will operate continuously.
5. Test for spillage at the draft hood relief opening after 5 minutes of main burner operation. Use the flame of a match or candle, or the smoke from a cigarette, cigar or pipe.
6. After it has been determined that each appliance remaining connected to the common venting system properly vents when tested as outlined above, return doors, windows, exhaust fans and any other gas-burning appliance to their previous condition of use.
7. Any improper operation of the common venting system should be corrected so the installation conforms with the National Fuel Code, NFPA-54/ANSI -Z223.1-latest revision, or section 5 of CSA-B149 for Canadian standards. When resizing any portion of the common venting system, the common venting system should be resized to approach the minimum size as determined using the appropriate tables in part 11 in the National Fuel Gas Code, NFPA-54/ANSI- Z223.1-latest revision, or section 5 of CSA-B149 for Canadian standards.

VI. PLACING THE BOILER

The boiler should be placed to provide the most direct connections to the combustion air, vent and system piping as possible.

Place crated boiler as close to selected location as possible and uncrate boiler. The uncrated boiler may be moved into position with an appliance dolly or 2-wheel hand truck. The dolly or hand truck should

be inserted under the **right hand side** of the boiler. It is possible to slide the boiler for a short distance on a smooth floor or surface.

NOTE: Refer to “*Locating The Boiler*” in Section V for required clearances for servicing and maintenance.

VII. NEAR BOILER PIPING

CAUTION

Copper supply and return piping must *NOT* be installed directly into aluminum boiler section castings due to galvanic corrosion between dissimilar metals. Iron or steel bushings or pipe nipples should be used between copper system piping and boiler to make final connection to boiler. Also, the use of dielectric unions is acceptable. The packaged boiler is furnished with iron piping in the front boiler section for the supply and return connections.

When the installation of the boiler is for a new heating system, first install all of the radiation units (panels, radiators, baseboard, or tubing) and the supply and return mains. After all heating system piping and components have been installed, make final connection of the system piping to the boiler.

A hot water boiler installed above radiation level must be equipped with a low water cut off device (included with boiler). A periodic inspection is necessary, as is flushing of float type devices, per low water cut off manufacturers specific instructions.

EXPANSION TANK AND MAKE-UP WATER

Determine required system fill pressure, system design temperature, and system water content. Boiler

contains 2.6 gallons (U.S.). Size expansion tank accordingly. Consult expansion tank manufacturer for proper sizing information. Connect properly sized expansion tank (not furnished) as shown in **Figure #6** for diaphragm type expansion tank. For diaphragm type expansion tanks, adjust the tank air pressure to match the system fill pressure. Install air vent (furnished) as shown for diaphragm type expansion tank system only. Install make-up water connections as shown and per local codes. If a pressure reducing valve is used, adjust to match the system fill pressure. In connecting the cold make-up water supply to the boiler, make sure that clean water supply is available. When the water supply is from a well or pump, a sand strainer should be installed at the pump.

PRESSURE RELIEF VALVE / TEMPERATURE PRESSURE GAUGE

The boiler is furnished with a relief valve and temperature pressure gauge in the boiler parts bag. Install vent relief valve as shown in **Figure #7**. Provide $\frac{3}{4}$ " piping from the relief valve to a local floor drain, but leave an air gap between piping and drain. No shut-off of any description shall be placed between safety relief valve and the boiler, or on the discharge pipes between such safety valve and the atmosphere. Installation of the safety relief valve shall conform to ANSI/ASME Boiler and Pressure Vessel Code, Section IV. The manufacturer is not responsible for any water damage.

Figure #6

DIAPHRAGM TYPE EXPANSION TANK PIPING

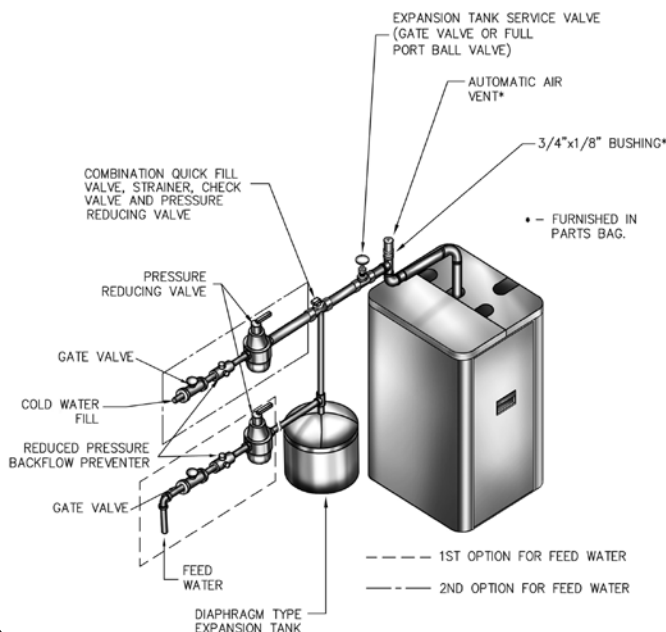
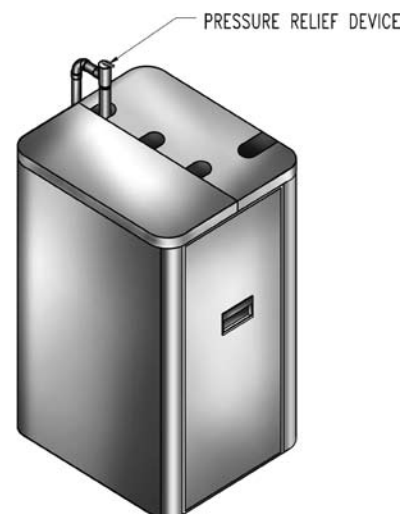

Figure #7

RELIEF VALVE DISCHARGE PIPING



VII. NEAR BOILER PIPING

Figure #8

SINGLE ZONE BOILER PIPING

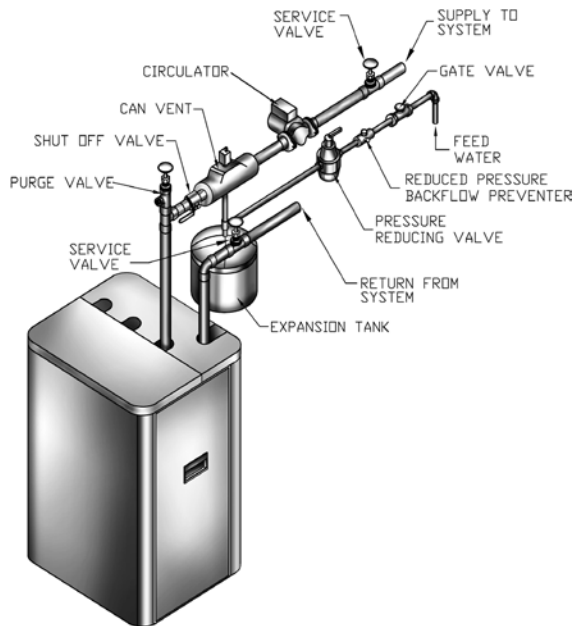

Figure #9b

MULTI ZONE BOILER PIPING WITH ZONE VALVES

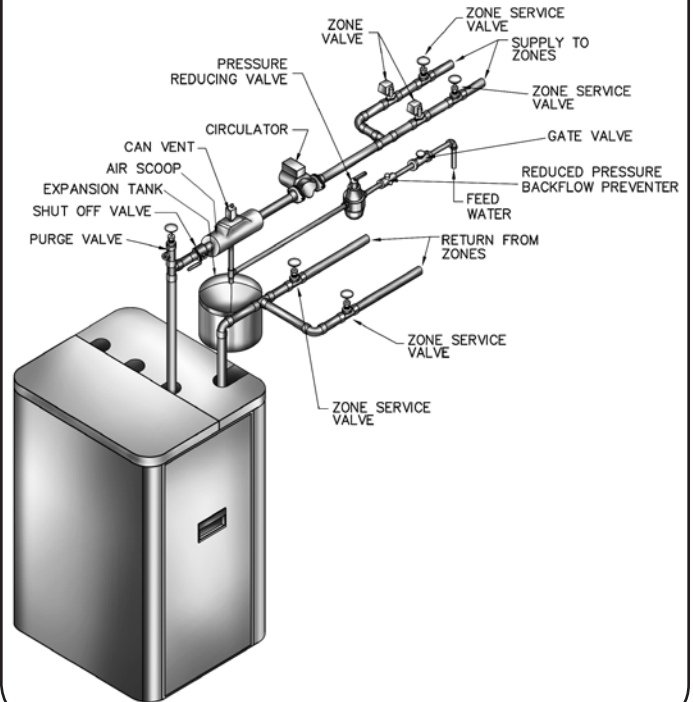
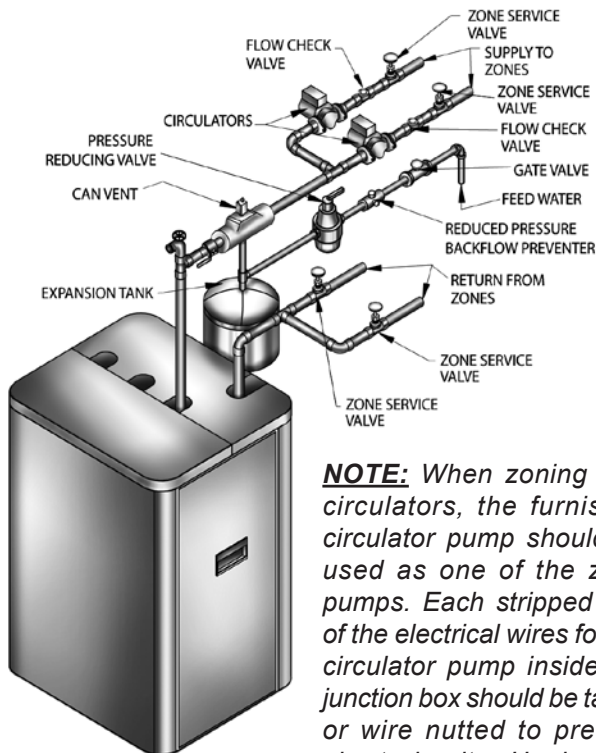

Figure #9a

MULTIZONE BOILER PIPING WITH CIRCULATORS



NOTE: When zoning with circulators, the furnished circulator pump should be used as one of the zone pumps. Each stripped end of the electrical wires for the circulator pump inside the junction box should be taped or wire nutted to prevent short circuits. Unplug the circulator pump wiring at the integrated boiler control.

SUPPLY AND RETURN LINES

The packaged boiler unit is set up to receive 1 $\frac{1}{4}$ " NPT supply and return piping from top access.

NOTE: The circulator pump and isolation valves are furnished within a carton inside the boiler cabinet and can be installed at the installer preferred location.

VII. NEAR BOILER PIPING

CONDENSATE DRAIN REQUIREMENTS

Condensate drain line to be pitched down to floor drain at a minimum of $\frac{1}{4}$ " per foot. An external condensate pump (not furnished) may be used if floor drain is not available. The condensate pump must be designed for flue gas condensate application.

Figure #10

CONDENSATE DRAIN PIPING

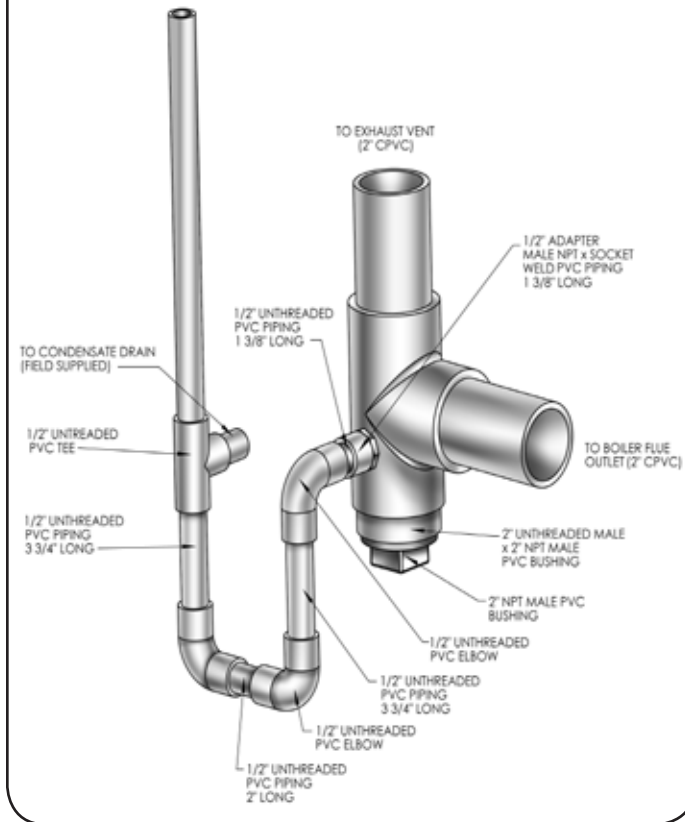

NOTES:

1. Condensate trap is to be built in the field per **Figure #10**
2. Wood frame or blocks may be used to raise the boiler to maintain drain pitch or to be above external condensate pump reservoir.
3. There is a 115 volt AC receptacle provided on the service switch junction box which is located at the boiler right side, to provide power for an external condensate pump (if needed).

CONDENSATE DRAIN PIPING

The condensate trap is to be field installed as previously shown in **Figure #10**. Provided are $\frac{1}{2}$ " PVC fittings for the condensate drain trap (assembled in the field). The condensate drain is to be pitched down to the floor drain at a minimum of $\frac{1}{4}$ " per foot.

The $\frac{1}{2}$ " diameter schedule 40 PVC condensate drain piping and pipe fittings must conform to ANSI standards and ASTM D1785 or D2846. Schedule 40 PVC cement and primer must conform to ASTM D2564 or F493. In Canada, use CSA or ULC certified schedule 40 PVC drain pipe and cement.

A condensate pump with a reservoir (not furnished) may be used to remove condensate to a drain line (sanitary line) above boiler if a floor drain is not available or is inaccessible.

FILLING CONDENSATE TRAP WITH WATER

ON INITIAL START UP THE CONDENSATE TRAP MUST BE MANUALLY FILLED WITH WATER.

The following are the steps required to initially fill the condensate trap for start up, these steps are only required at the initial start up or if maintenance requires draining of the condensate trap:

1. Pour about 1 cup of cold tap water into the condensate trap vent.
2. Excess water should go through the condensate drain line. Verify proper operation of the drain line (and external condensate pump if used).

CHILLED WATER PIPING

The boiler, when used in connection with a refrigeration system, must be installed so the chiller medium is piped in parallel with the boiler with appropriate valves to prevent the chilled medium from entering the boiler.

The boiler piping system of a hot water boiler connected to heating coils located in air handling units where they may be exposed to refrigerated air circulation must be equipped with flow control valves or other automatic means to prevent gravity circulation of the boiler water during the cooling cycle.

VIII. COMBUSTION AIR AND VENT PIPE

CONNECTIONS AND TERMINATION

IMPORTANT: To prevent damage to the gas burner and ensure proper operation of the unit, installer must clean and remove all shavings from the interior of all PVC pipe used on the air intake.

For boilers connected to gas vents or chimneys, vent installations shall be in accordance with part 7, Venting of Equipment, of the National Fuel Gas Code, ANSI Z223.1-latest revision, CSA-B149.1 and B149.2, and applicable provisions of the local building codes.

Provisions for combustion and ventilation air must be in accordance with section 5.3, Air For Combustion and Ventilation, of the National Fuel Gas Code, ANSI Z223.1-latest revision, CSA-B149.1 and B149.2, or applicable provisions of the local building code.

These boilers require a dedicated direct vent system. All air for combustion is taken directly from outdoors through the combustion air intake pipe. All flue products are discharged to the outdoors through the vent pipe.

1. See **Figures #1 – #2** in Section V, “Combustion Air and Vent Pipe Requirements,” for standard two-pipe roof and sidewall terminations and **Figures #3 – #5** (same section) for concentric vent terminations (roof termination is preferred). Combustion air and vent pipes must terminate together in same atmospheric pressure zone as shown. Construction through which vent and air intake pipes may be installed is a minimum ¼” and maximum 24” thickness.

2. Combustion air and vent pipe fittings must conform to one of the following American National Standards Institute (ANSI) and American Society for Testing and Materials (ASTM) standards:

- D1784 (schedule-40 CPVC)
- D1785 (schedule-40 PVC)
- D2665 (PVC-DWV)
- D2241 (SDR-21 and SDR-26 PVC)
- D2661 (ABS-DWV)
- F628 (schedule-40 ABS).

Pipe cement and primer must conform to ASTM standards D2564 (PVC) or D2235 (ABS).

In Canada construct all combustion air and vent pipes for this unit of CSA or ULC certified schedule-40 CPVC, schedule-40 PVC, PVC-DWV or ABS-DWV

pipe and pipe cement. SDR pipe is NOT approved in Canada.

For Canadian installations all plastic venting material must be listed to ULC S636.

3. Combustion air and vent piping connections on boiler are 2”, but must increase to 3”. Due to potential for flue gas temperatures over 155°F, the first 5 feet of vent pipe must be CPVC (furnished), the remaining vent pipe can be PVC. If any elbows are employed within the first 2 ½’ of vent, they must be CPVC. Two 30” pieces of 2” CPVC pipe and one 2” CPVC coupling are furnished with the boiler. (**Figure #11**)

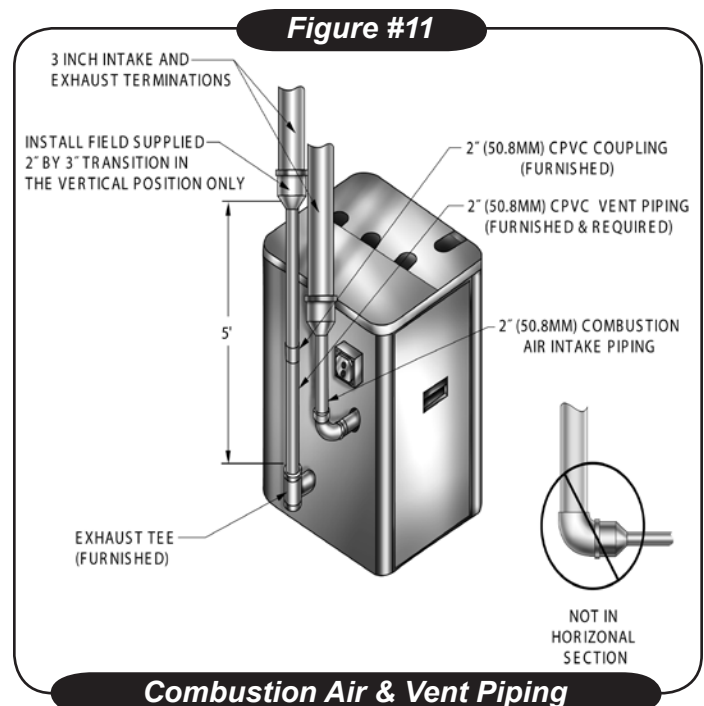

NOTE: The exhaust transition from 2” pipe must be made in a vertical run. (Transition pieces not included.)

3 in. Pipe Minimum Venting	3 in. Pipe Maximum Venting
6 ft. in length plus four (4) 90° elbows	60 ft. in length and up to four (4) 90° elbows

The length of pipe is counted from the boiler jacket (air intake pipe) or from vent tee (vent pipe). The first five feet of “Total Equivalent Length” of vent pipe must be CPVC.

Reduce the maximum vent length 5 feet per each additional elbow.

VIII. COMBUSTION AIR AND VENT PIPE

4. Combustion air and vent piping to be pitched back to boiler at minimum $\frac{1}{4}$ " per foot from intake and vent terminals so that all moisture in combustion air and vent piping drains to boiler. Pipes must be pitched continuously with no sags or low spots where moisture can accumulate and block the flow of air or flue gas. Combustion air and vent pipes must be airtight and watertight.
5. Consideration for the following should be used when determining an appropriate location for termination of combustion air and vent piping:
 - Comply with all clearances required as stated in paragraph 6 (below)
 - Termination should be positioned where vent vapors will not damage plants/shrubs, air conditioning equipment, or siding on the house.
 - Termination should be positioned so that it will not be effected by wind eddy, air born leaves, snow, or recirculated flue gases.
 - Termination should be positioned where it will not be subjected to potential damage by foreign objects, such as stones, balls, etc.
 - Termination should be positioned where vent vapors are not objectionable.
 - Put vent on a wall away from the prevailing winter wind. Locate or guard the vent to prevent accidental contact with people or pets.
 - Terminate the vent above normal snowline. Avoid locations where snow may drift and block the vent. Ice or snow may cause the boiler to shut down if the vent becomes obstructed.
 - Under certain conditions, flue gas will condense, forming moisture, and may be corrosive. In such cases, steps should be taken to prevent building materials at the vent from being damaged by exhaust of flue gas.
6. The venting system shall terminate at least 3 feet above any forced air inlet (except the boiler's combustion air inlet) within 10 feet. The venting system shall terminate at least 12 inches from any air opening into any building. The bottom of the vent shall be located at least 12 inches above grade. Termination of the vent shall be not less than 7 feet above an adjacent public walkway. The vent terminal shall not be installed closer than 3 feet from the inside corner of an L shaped structure. Termination of the vent should be kept at least 3 feet away from

vegetation. The venting system shall terminate at least 4 feet horizontally from, and in no case above or below electric meters, gas meters, regulators, and relief equipment.

If multiple terminations are used, there must be a minimum of 12 inches between the exhaust of one termination and the air intake of the next termination. See **Figures #1 – #3** in Section E5 for illustrations.

NOTE: All field installed vent pipe must be 3".

INSTALLATION

1. Attach combustion air intake piping to supplied Fernco 2" coupling on CVI gas valve. Attach vent piping to furnished 2" CPVC vent tee on draft inducer outlet.

NOTE: All pipe joints are to be water tight.

2. Working from the boiler to the outside, cut pipe to required length(s).
3. Deburr inside and outside of pipe. Remove all chips and shavings.
4. Chamfer outside edge of pipe for better distribution of primer and cement.
5. Clean and dry all surfaces to be joined.
6. Check dry fit of pipe and mark insertion depth on pipe.

NOTE: It is recommended that all pipes be cut, prepared, and pre-assembled before permanently cementing any joint.

7. After pipes have been cut and pre-assembled, apply cement primer to pipe fitting socket and end of pipe to insertion mark. Quickly apply approved cement to end of pipe and fitting socket (over primer). Apply cement in light, uniform coat on the inside of socket to prevent buildup of excess cement. Apply second coat.
8. While cement is still wet, insert pipe into socket with a $\frac{1}{4}$ turn twist. Be sure pipe is fully inserted into fitting socket.
9. Wipe excess cement from joint. A continuous bead of cement will be visible around perimeter of a properly made joint.

VIII. COMBUSTION AIR AND VENT PIPE

- Handle pipe joint carefully until cement sets.
- Support combustion air and vent piping a minimum of every 5 feet using pre-formed metal hanging straps. Do not rigidly support pipes. Allow for movement due to expansion and contraction.
- Slope combustion air and vent pipes toward boiler a minimum of $\frac{1}{4}$ " per linear foot with no sags between hangers.
- Use appropriate methods to seal openings where vent and combustion air pipes pass through roof or side wall.

NOTE: Rigid supports will cause excess noise in vent piping.

IX. GAS SUPPLY PIPING

CHECK GAS SUPPLY

TABLE #5 - GAS SUPPLY PRESSURE

Pressure	Natural Gas	Propane Gas
Minimum	4" w.c.	10" w.c.
Maximum	10" w.c.	14" w.c.

Please check line pressure while unit is running.

The gas pipe to your boiler must be the correct size for the length of run and for the total BTU per hour input of all gas utilization equipment connected to it. See **Tables #6A & #6B** for proper size. Be sure your gas line complies with local codes and gas company requirements.

TABLE #6A - NATURAL GAS PIPING SIZES

Pipe Length	Pipe Capacity - BTU/Hr. Input ⁽¹⁾			
	$\frac{1}{2}$ "	$\frac{3}{4}$ "	1"	1 $\frac{1}{4}$ "
20'	92,000	190,000	350,000	625,000
40'	63,000	130,000	245,000	445,000
60'	50,000	105,000	195,000	365,000

TABLE #6B - PROPANE GAS PIPING SIZES

Pipe Length	Pipe Capacity - BTU/Hr. Input ⁽¹⁾			
	Copper Tubing ⁽²⁾		Iron Pipe	
	$\frac{5}{8}$ "	$\frac{3}{4}$ "	$\frac{1}{2}$ "	$\frac{3}{4}$ "
20'	131,000	216,000	189,000	393,000
40'	90,000	145,000	129,000	267,000
60'	72,000	121,000	103,000	217,000

⁽¹⁾Includes Fittings

⁽²⁾Outside Diameter

The boiler and its individual shutoff valve must be disconnected from the gas supply piping system during any pressure testing of that system at test pressures in excess of $\frac{1}{2}$ psig (3.5kPa).

IMPORTANT: The length of pipe or tubing should be measured from the gas meter or propane second stage regulator.

CONNECTING THE GAS PIPING

Refer to **Figure #12** for the general layout at the boiler. The gas line enters the boiler through the left side panel.

Figure #12

GAS PIPING

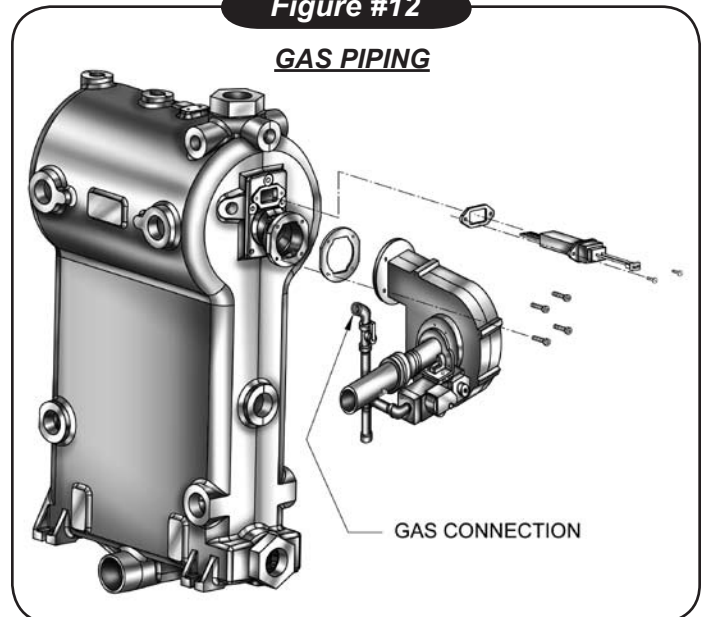

The boiler is equipped with a $\frac{1}{2}$ " NPT connection on the gas valve for supply piping and $\frac{1}{2}$ " NPT ball cock for manual shut off. The following rules apply:

- Use only those piping materials and joining methods listed as acceptable by the authority having jurisdiction, or in the absence of such requirements, by the National Fuel Gas Code, ANSI Z223.1-latest revision. In Canada, follow the CAN/CGA B149.1 and .2 Installation Codes for Gas Burning Appliances and Equipment.

IX. GAS SUPPLY PIPING

CONNECTING THE GAS PIPING *Continued*

2. Use pipe joint compound suitable for liquefied petroleum gas on male threads only.
3. Use ground joint unions.
4. Install a sediment trap upstream of gas controls.
5. Use two pipe wrenches when making the connection to the gas valve to keep it from turning.
6. Install a manual shutoff valve in the vertical pipe about 5 feet above floor outside the boiler jacket.
7. Tighten all joints securely.
8. Propane gas connections should only be made by a licensed propane installer.
9. Two stage regulation should be used by the propane installer.

10. Propane gas piping should be checked out by the propane installer.

11. It is recommended to use a ½" union suitable for natural and propane gas after the ball cock to facilitate service on the unit.

CHECKING THE GAS PIPING

After all connection have been made, check immediately for leaks. Open the manual shutoff valve. Test for leaks by applying soap suds (or a liquid detergent) to each joint. Bubbles forming indicate leak. **CORRECT EVEN THE SMALLEST LEAK AT ONCE.**

! WARNING

Never use a match or open flame to test for leaks.

X. ELECTRICAL WIRING

! WARNING

Turn off electrical power at fuse box before making any line voltage connections. Follow local electrical codes.

All electrical work must conform to local codes as well as the National Electrical Code, ANSI/NFPA-70, latest revision. In Canada, electrical wiring shall comply with the Canadian Electrical Codes, CSA-C22.1 and .2.

ELECTRIC POWER SUPPLY

Prior to making any line voltage connections, service switch at boiler should be in the off position and the power turned off at the fuse box.

Run a 120 volt circuit from a separate over current protection device in the electrical service entrance panel.

NOTE: Use copper conductors only.

This should be a 15 ampere circuit. A service switch has been pre-wired and located on the exterior boiler jacket. See **Figure #13** for diagram showing location of service switch junction box and power supply connection points. Connect black (hot) lead from the power supply to either of the unused brass screws on the service switch. Connect the white (neutral) lead from the power supply to the white screw on the service switch. Connect the green (ground) lead from the

Figure #13

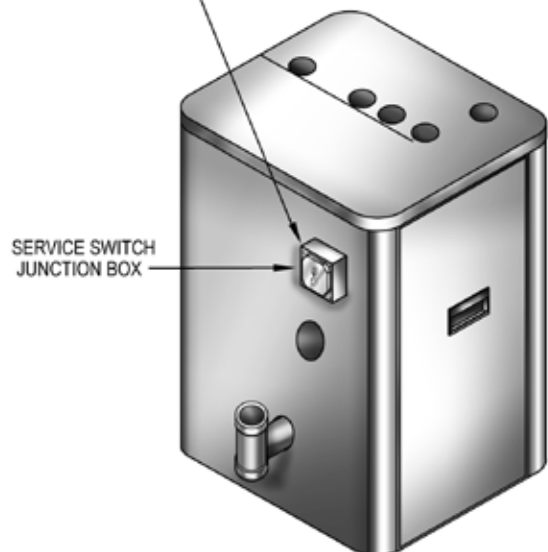
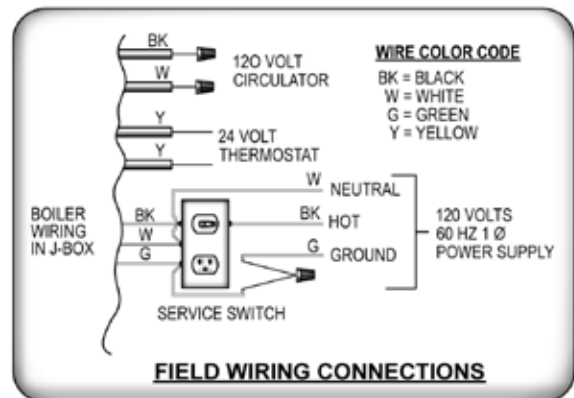

X. ELECTRICAL WIRING

power supply to the ground (green) screw on the service switch. The receptacle on the service switch is always powered regardless of whether the switch is on or off, and could be used as a power supply for an external condensate pump if one is used.

The boiler, when installed, must be electrically grounded in accordance with the requirements of the authority having jurisdiction or, in the absence of such requirements, with the National Electrical Code, ANSI/NFPA-70, latest revision. In Canada, electrical wiring shall comply with the Canadian Electrical Codes, CSA-C22.1 and .2.

Run a 14 gauge or heavier copper wire from the boiler to a grounded connection in the service panel or a properly driven and electrically grounded ground rod.

INSTALLING THE THERMOSTAT

The thermostat location has an important effect on the operation of your boiler system. **BE SURE TO FOLLOW THE INSTRUCTIONS INCLUDED WITH YOUR THERMOSTAT.**

AVOID THE FOLLOWING	
Dead Spots	Corners Alcoves Behind doors
Cold Spots	Concealed pipes or ducts Stairwells - drafts Unheated rooms on the other side of the wall
Hot Spots	Concealed pipes Fireplaces TVs or radios Lamps Direct sunlight Kitchens

Locate the thermostat about five feet above the floor on an inside wall. It may be mounted directly on the wall or on a vertical mounted outlet box. It should be sensing average room temperature.

Set heat anticipator at 0.7 amps. Connect 24 volt thermostat leads to the two (2) yellow wires located in service switch junction box, located on outer jacket of boiler. See **Figure #13** for service switch junction box and thermostat field wiring connections.

CONNECT CIRCULATOR PUMP WIRING

See **Figures #14A & #14B** (following page) for service switch junction box and circulator pump field wiring connections. If the two 120 volt circulator wire terminals inside the junction box are not used, please leave the two wire nuts to prevent the short circuit.



Label all wires prior to disconnection when servicing controls. Wiring errors can cause improper and dangerous operation. **VERIFY PROPER OPERATION AFTER SERVICING.**

X. ELECTRICAL WIRING

Figure #14A

SCHEMATIC WIRING CONNECTIONS

NOTE: If any of the original wire as supplied with this appliance must be replaced, it must be replaced with type 150°C Thermoplastic wire or its equivalent.

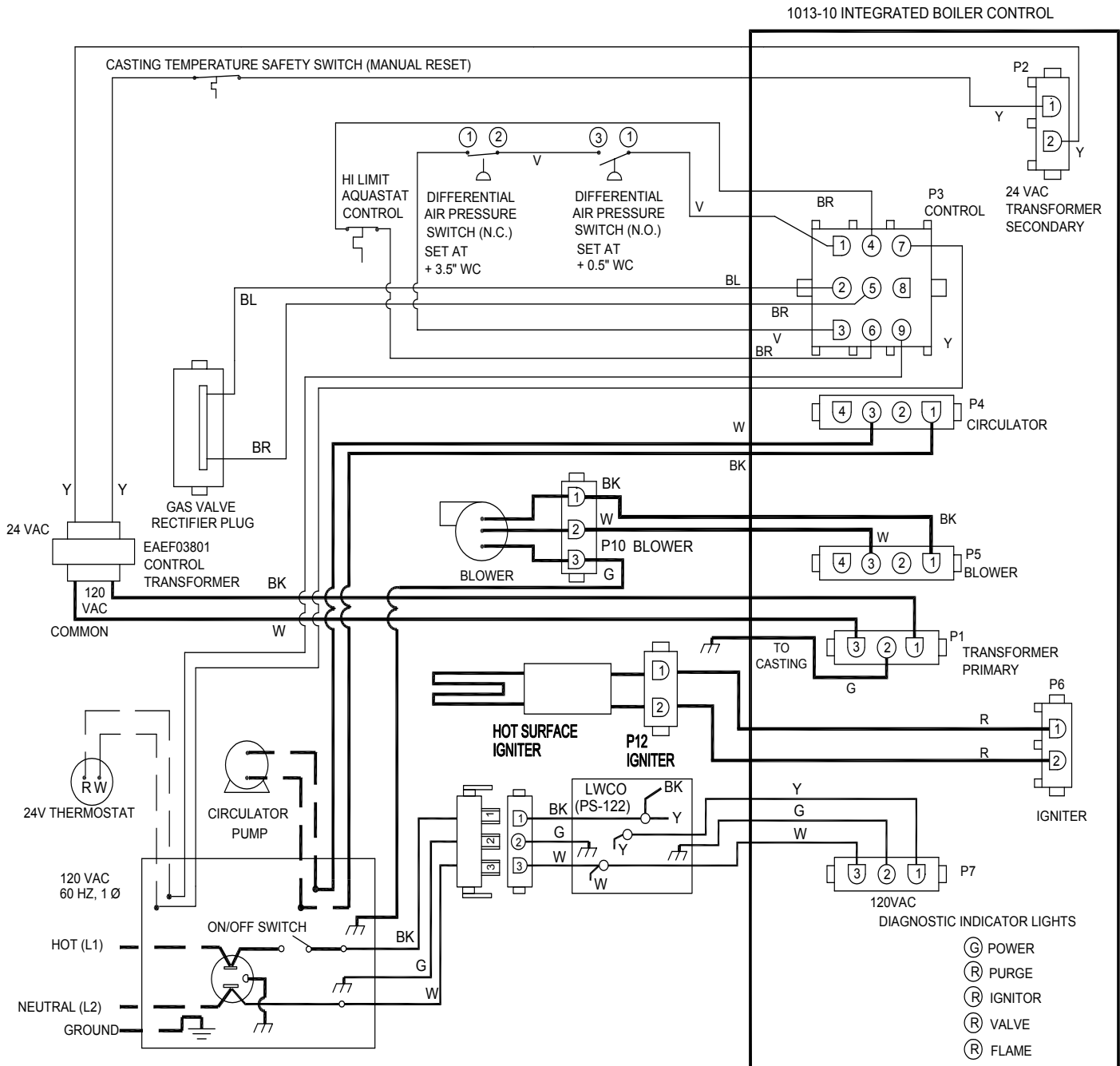

(NOTE: USE COPPER CONDUCTORS ONLY)

X. ELECTRICAL WIRING

Figure #14B

LADDER WIRING DIAGRAM

NOTE: If any of the original wire as supplied with this appliance must be replaced, it must be replaced with type 150°C Thermoplastic wire or its equivalent.

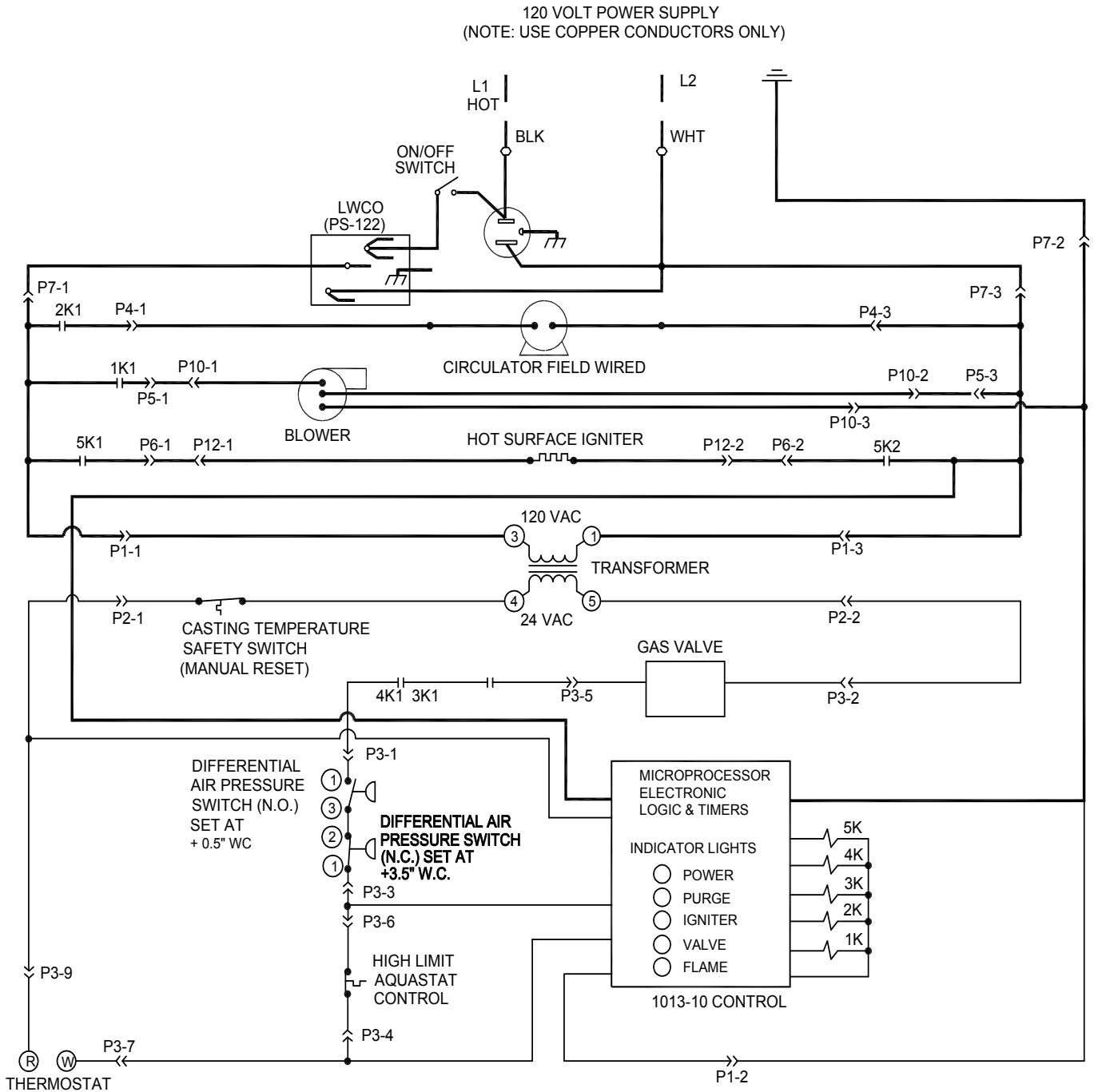

XI. CONTROLS AND ACCESSORIES

This section provides a brief description of the key controls and accessories found in this boiler.

See Section XVII, "Troubleshooting," in this installation manual for detailed sequences of operation and troubleshooting procedures. See the separately provided "Repair Parts Manual" for locations of all control components and accessories described.

INTEGRATED BOILER CONTROL (IBC)

The Integrated Boiler Control (IBC) is a microprocessor based controller for high efficiency gas boilers that monitors all safety controls and which controls the operation of the combustion air blower, circulator pump, burner, and a combination hot surface igniter/flame sensor. This controller is not intended for use with a vent damper. This controller is mounted on the control panel inside the boiler and contains five diagnostic indicator lights.

GAS CONTROL VALVE

The electronic 24 volt gas control valve contains a 1:1 gas/air pressure regulator to control gas flow to the main burner of the appliance, is suited for both natural and LP gas, and is rated in accordance with ANSI Z21.21 - latest revision and CGA-6.5-M95.

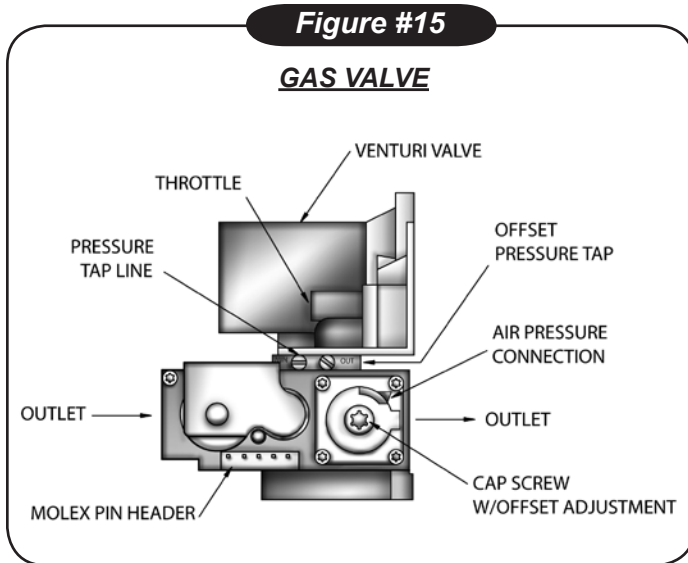

HOT SURFACE IGNITER

The 120 volt hot surface igniter heats up to 1800°F to initiate combustion of the gas in the burner. The igniter is mounted next to the burner through the gas/air mixer. The igniter also serves as a means for proving the main burner flame by flame rectification. In the event of

a lack of flame signal on three consecutive trials for ignition, the IBC will lock out. The "Valve" and "Flame" diagnostic indicator lamps (see **Figure #16**) will blink indicating the failure mode as a lack of flame signal. The IBC is manually reset from lockout by either removing and reestablishing the thermostat's call for heat, or by turning the service switch off, then back on.

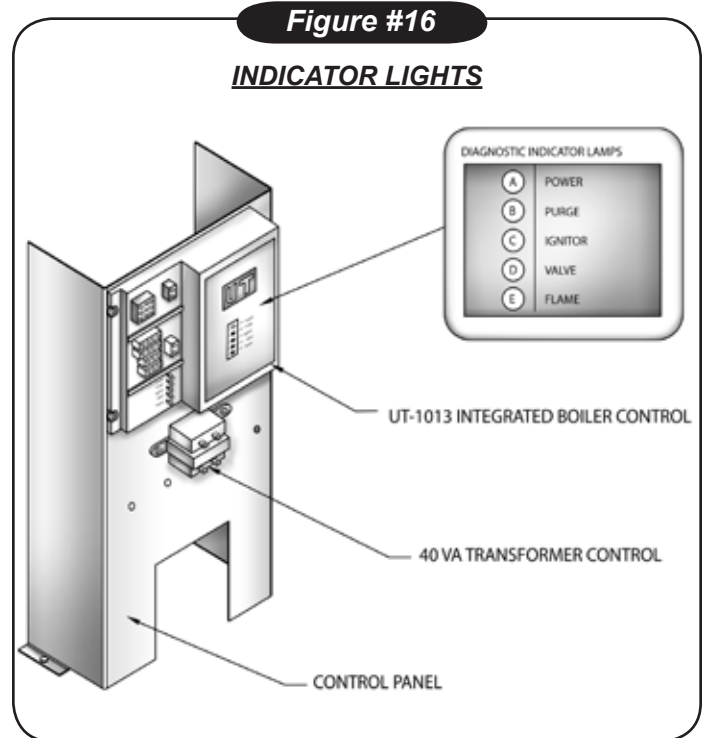

HIGH LIMIT AQUASTAT CONTROL

The high limit aquastat control determines the maximum boiler water temperature and also provides a means for protecting the boiler and heating system from unsafe operating conditions which could damage the boiler. The aquastat is mounted in the 1/2" NPT control well and 3/4" x 1/2" bushing on the top of the front boiler section at the hot water outlet. The aquastat is tied in with the IBC and is factory set at 180°F water temperature. The high limit setpoint is field adjustable and may be set anywhere between 100°F and 200°F. The field setpoint adjustment for each installation depends on heating system requirements. The aquastat automatically resets when the boiler water temperature drops 20°F below the setpoint value. This reset value can be field adjusted within a range of 5-30°F.

NOTE: The maximum setpoint of the aquastat must not exceed 200°F.

XI. CONTROLS AND ACCESSORIES

CASTING TEMPERATURE SAFETY SWITCH

In the event of lack of or loss of water in the boiler, the casting temperature safety switch (230°F setpoint) installed on the top of the aluminum boiler section behind the supply piping shuts off the boiler by shutting off power to the IBC and causes the power indicator light to go out. This fault requires manual reset of the casting temperature safety switch to restart the boiler. Verify that the boiler is properly filled with water before resetting this switch.



WARNING

Never run cold water into a hot, empty boiler.

DIFFERENTIAL PRESSURE SWITCHES

The diaphragm type differential pressure switches are connected by vinyl tubing to the gas valve and the air inlet connection on the negative side and the sight glass adapter on the positive side. The pressure switches monitor air flow by sensing the differential pressure measured in inches of water (" w.c.). The factory settings on these switches are 0.5" w.c. on the normally open switch and 3.5" w.c. for the normally closed switch. See Section XVI, "Detailed Sequence of Operation," for details on the operation of the differential pressure switches.

BLOWER

The blower provides a means for pushing combustion air into and through the mixer, the burner, the flue ways of the cast aluminum boiler section before being discharged through the vent piping to the outdoors.

CIRCULATOR PUMP

Every forced hot water system requires at least one circulating pump. The circulating pump imparts the necessary energy to move the water through the closed loop supply and return piping systems, terminal heating equipment (finned tube radiators, etc.) and back through the boiler for reheating. To provide the required hot water flow rates, the circulator pump must be properly sized to overcome frictional losses (usually measured in feet of water, also referred to as "pump head loss") of the supply and return piping systems and boiler. The circulator pump is furnished in a carton within the boiler cabinet. The circulator(s) should always be located on the downstream (i.e., "pumping away") side of the expansion tank.

DRAIN VALVE

The manual drain valve provides a means of draining the water in the heating system, including the boiler and hot water supply and return piping systems installed above the drain valve. This drain valve is installed in the ¾" tapping at the bottom of the boiler. Any piping installed below the elevation of this drain valve will require additional drain valves to be installed at low points in the piping systems in order to drain the entire system.

A.S.M.E. RATED PRESSURE RELIEF VALVE

Each boiler must have a properly sized and installed A.S.M.E. rated pressure relief valve. Water expands as it is heated by the burner/boiler sections. If there is no place for the water to expand its volume, (i.e., a properly sized and functioning expansion tank) pressure on the inside of the boiler and heating system will increase. The furnished relief valve will automatically open at 30 psig pressure to relieve the strain on the boiler and heating system from the increasing pressure. The pressure relief valve discharge must be piped with the same size as the valve discharge opening to an open drain, tub or sink, or other suitable drainage point not subject to freezing, in accordance with A.S.M.E. specifications. Failure to provide the pressure relief valve with piping as herein described may cause water damage and/or serious bodily injury. The boiler manufacturer is not responsible for any water damage or personal injury.

BLOCKED VENT SAFETY SHUTOFF

The boiler is equipped with a blocked vent safety shutoff which shuts off the main burner gas in the event that the airflow of combustion products through the flue-way is reduced. In the event of a blocked flue-way, enough air will not be available to support combustion and the IBC will lock out due to loss of adequate air flow.

Pressure switches monitor air flow by sensing differential pressure. The contacts are normally open and close when the draft inducer is running and causing the differential pressure at the switch to exceed its setting. The closed switch proves there is adequate air flow for combustion.

The pressure switch shuts off the main burner if the differential pressure is inadequate due to a blocked vent pipe, a blocked air intake, a blocked boiler section, or a blocked air inducer. After 5 minutes of inadequate differential pressure, the IBC will lock out.

XI. CONTROLS AND ACCESSORIES

The “Purge” indicator lamp (see **Figure #16**) will blink, indicating a failure to prove adequate combustion air flow or flue gas flow. The IBC will automatically reset after 15 minutes or can be manually reset as noted in the section titled “*Hot Surface Igniter.*” If the boiler cannot be restored to normal operating condition by resetting the control, contact a qualified service agency to check the heat exchanger flue-ways for blockage.

LOW WATER CUT OFF

This unit is equipped with a low water cut off control that protects against dry firing. This control provides burner cut off if there is an unsafe water loss, which can result from a broken or leaking radiator, pipe, or boiler. A water/glycol mixture up to 50% concentration may be used with the low water cut off.

EXTERNAL CONDENSATE PUMP (Optional)

For installations where there is no floor drain or other appropriate drainage available to receive condensate from the boiler, an external float activated condensate pump with integral sump (supplied by others) is required.

The condensate pump can be piped to a remote tie in point to a sanitary sewer system. For this application, the boiler must be installed so that proper pitch of piping to the external condensate reservoir (sump) can be accomplished. Use wood frame or blocks (not factory supplied) to raise boiler as required for proper installation.

XII. STARTUP

WATER TREATMENT AND FREEZE PROTECTION

1. Consult local water treatment specialist for recommendations if your water pH levels are below of 7.0 or hardness is above 7 grains hardness.

- a. This boiler is designed for use in a closed hydronic heating system ONLY!
- b. Excessive feeding of fresh make-up water to the boiler may lead to premature failure of the boiler sections.

2. Use clean fresh tap water for initial fill and periodic make-up of boiler.

- a. A sand filter must be used if fill and make-up water from a well is to be used.
- b. Consideration should be given to cleaning the heating system, particularly in retrofit situations where a new boiler is being installed in an older piping system.
- c. In older systems, obviously discolored, murky, or dirty water, or a pH reading below 7, are indications that the system should be cleaned.
- d. A pH reading between 7 and 8 is preferred when antifreeze is not used in the system.

3. Antifreeze, if needed, must be of a type specifically designed for use in closed hydronic heating systems and be compatible with type 356 T6 alumi-

num at operating temperatures between 20°F and 250°F.

- a. Use of antifreeze must be in accordance with local plumbing codes.
- b. Pure glycol solutions are very corrosive, therefore hydronic system antifreeze typically contains corrosion inhibitors. Different brands of hydronic system antifreeze contain different types of corrosion inhibitors. Some brands have corrosion inhibitors that break down more rapidly or become ineffective at higher temperatures when used with aluminum. This could lead to premature failure of the aluminum boiler. Consult the antifreeze manufacturer on the compatibility of their product with aluminum.
- c. Follow the antifreeze manufacturer’s instructions on determining proper ratio of antifreeze to water for the expected low temperature conditions, and for maintaining the quality of the antifreeze solution from year to year. Improperly maintained antifreeze solutions will gradually lose their ability to protect the aluminum boiler from corrosion.
- d. **The recommended premixed antifreeze solution is INTERCOOL NFP-50.** This product is sold direct to distributors by the manufacturer. Please contact Interstate Chemical

XII. STARTUP

Company at 1-800-422-2436 or your distributor for more information.

Use of an alternate manufacturer's premix antifreeze is acceptable if the product specifications are comparable with those of the recommended premix antifreeze and the antifreeze is compatible with type 356 T6 aluminum. Use of incompatible antifreeze could damage the heat exchanger and will void the product warranty.

The antifreeze must be maintained per the specifications of the manufacturer. Failure to do so will result in the warranty being voided. Follow the antifreeze manufacturer's instructions on determining the proper ratio of antifreeze to water for the expected low temperature conditions and for maintaining the antifreeze solution from year to year.

- e. **DO NOT USE AUTOMOTIVE ANTIFREEZE**, as the type of corrosion inhibitors used will coat the boiler's heat transfer surfaces and greatly reduce capacity and efficiency.
- f. Use of antifreeze in any boiler will reduce heating capacity by as much as 10-20% due to differing heat transfer and pumping characteristics. This must be taken into consideration when sizing the heating system, pump(s) and expansion tank. Consult antifreeze manufacturer's literature for specific information on reduced capacity.
- g. Water content of the boiler is 2.6 gallons (10 liters).
- h. Antifreeze will raise the pH of the water in a heating system to between 8.0 and 10.0. This is due to the corrosion inhibitors in the antifreeze.

FILLING BOILER WITH WATER AND PURGING AIR FOR SYSTEMS WITH DIAPHRAGM TYPE EXPANSION TANKS

Refer to the appropriate diagrams in Section VII, "Near Boiler Piping," for more information.

1. Close all zone service valves on the supply and return piping. Open the feed valve and fill boiler with water. Make sure air vent is open. Hold relief valve open until water runs air free for five seconds

to rapidly bleed air from boiler, then let the relief valve snap shut.

2. Open the zone service valve on the supply pipe for the first zone. Open the purge valve on the first zone. Feed water will fill the zone, pushing air out the purge valve. Close the purge valve when the water runs air free. Close the zone service valve.
3. Repeat step 2 for all remaining zones.
4. Open all service valves. Any air remaining trapped in the return lines between the service valves and the boiler will be pushed towards the air vent when the boiler is placed in operation.
5. Inspect piping system. Repair any leaks immediately.

FILLING BOILER WITH WATER AND PURGING AIR FOR SYSTEMS WITH CONVENTIONAL CLOSED TYPE EXPANSION TANKS

Refer to the appropriate diagrams in Section VII, "Near Boiler Piping," for more information.

1. Close all zone service valves on the supply and return piping and close the expansion tank service valve. Drain expansion tank. Open the feed valve and fill boiler with water. Hold relief valve open until water runs air free for five seconds to rapidly bleed air from boiler, then let the relief valve snap shut.
2. Open the zone service valve on the supply pipe for the first zone. Open the purge valve on the first zone. Feed water will fill the zone, pushing air out the purge valve. Close the purge valve when the water runs air free. Close the zone service valve.
3. Repeat step 2 for all remaining zones.
4. Open the expansion tank service valve and the tank vent. Fill the tank to the proper level and close the tank vent. Remove the handle from the expansion tank service valve so the homeowner doesn't accidentally close it.
5. Open all service valves. Any air remaining trapped in the return lines between the service valves and the boiler will be pushed towards the expansion tank when the boiler is placed in operation.
6. Inspect piping system. Repair any leaks immediately.

XII. STARTUP

NOTE: DO NOT use stop leak compounds. Leaks in threaded connections in the aluminum boiler sections must be repaired immediately. Aluminum threads will not seal themselves.

PLACING BOILER IN OPERATION

READ BEFORE OPERATING APPLIANCE

1. This appliance does not have a pilot. It is equipped with an ignition device which automatically lights the burner. Do NOT try to light this burner by hand.
2. Before operating smell all around the appliance area for gas. Be sure to smell next to the floor because some gas is heavier than air and will settle to the floor.

WHAT TO DO IF YOU SMELL GAS

- Do not try to light any appliance.
 - Do not touch any electric switch or use any phone in the building.
 - Immediately call your gas supplier from a neighbor's phone. Follow the gas supplier's instructions.
 - If you can not contact your gas supplier, call the fire department.
3. Use only your hand to turn the gas shut off valve. Never use tools. If the valve will not turn by hand, do not try to repair it, call a qualified service technician. Force or attempted repair may cause fire or explosion.
 4. Do not use this appliance if any part has been under water. Immediately call a qualified service technician to inspect the appliance and to replace any part of the control system and any gas control which has been under water.

OPERATING INSTRUCTIONS

1. **STOP!** Read the safety information above before operating this appliance.
2. Set the thermostat to the lowest setting.
3. Turn off all electrical power to the appliance.

4. This appliance does not have a pilot. It is equipped with an ignition device which automatically lights the burner. Do NOT try to light this burner by hand.
5. Remove the front jacket panel.
6. Turn off the gas shut off valve. Valve handle should be perpendicular to the gas pipe.
7. Wait five minutes for any gas to clear. Then smell for gas, including near the floor. If you smell gas, **STOP!** Follow instructions at left under "*What To Do If You Smell Gas.*" If you do not smell gas, go to the next step.
8. Turn the gas shut off valve to the "On" position. The handle on the valve should be parallel to the gas pipe.
9. Replace the front jacket panel.
10. Turn on all electrical power to the appliance.
11. Set thermostat to desired setting.
12. If the appliance will not operate, follow the instructions in "*To Turn Off Gas To Appliance*" (below) and call your service technician or gas supplier.

TO TURN OFF GAS TO APPLIANCE

1. Set the thermostat to the lowest setting.
2. Turn off all electric power to the appliance if service is to be performed.
3. Remove the front jacket panel.
4. Turn gas shut off valve off. Handle should be perpendicular to the gas pipe.
5. Replace the front jacket panel.

Safe lighting and other performance criteria were met with the gas manifold and control assembly provided on the boiler when the boiler underwent tests specified in ANSI Z21.13-latest revision.

IF BURNER APPEARS TO PULSATE DURING IGNITION:

1. Turn off boiler power and shut off gas supply to the boiler.
2. Take the burner assembly apart by removing the combustion air blower and gas valve/venturi assembly from the boiler and visually inspect the inside of the burner. Look for any debris (PVC shavings, etc.) and if anything is present, remove it.
3. Reassemble burner assembly, turn gas supply and boiler power back on, and relight boiler.

IF BURNER STILL PULSATES OR FAILS TO LIGHT:

1. Check for proper vent and intake pipe sizing and for proper vent lengths and vent configuration by referring to, *"Before Installing The Boiler,"* and *"Combustion Air and Vent Pipe,"* sections in this manual.
2. Check for proper gas supply pressure and proper gas line sizing to the boiler by referring to, *"Gas Supply Piping,"* section in this manual.
3. Check for orifice in negative pressure hose at gas valve and 2" air intake pipe upstream of gas valve.
4. Relight boiler.
5. If boiler still does not light, the air inlet pipe may need to be disconnected to allow the boiler to start in order to verify the boiler firing rate and combustion properties. The inlet air pipe can be disconnected by removing the PVC inlet air piping from the Fernco fitting located on the air inlet of the gas valve/venturi assembly. Relight boiler.
6. When the boiler lights, the firing rate and combustion should be checked per the *"Adjustments and Checkout"* procedure Section of this manual. If the air inlet piping was disconnected in step 4 (above), leave it disconnected and make first adjustment. Then reconnect air inlet piping, recheck combustion CO₂, and adjust again if necessary.
7. If burner pulsation continues or boiler fails to light after performing the above procedures, please contact Technical Service at 1-800-325-5479 for further assistance.

XIII. CHECKOUT PROCEDURE & ADJUSTMENTS

VERIFY PROPER SEQUENCE OF OPERATION

The sequence can be followed via the diagnostic indicator lamps on the Integrated Boiler Control in **Figure #16** (Section XI). This is the normal sequence of operation. A more detailed sequence of operation containing potential faults can be found in the service hints section.

SEQUENCE OF OPERATION	DIAGNOSTIC INDICATOR LAMPS	
(1) Lamp A is illuminated, indicating that the integrated control is receiving 24 volts and is in standby waiting for the thermostat to call for heat.	A.	●
(2) Thermostat calls for heat, energizing the system circulator.	B.	○
(3) Integrated boiler control performs self check of internal circuitry, lasting approximately two seconds, and energizes the draft inducer.	C.	○
	D.	○
	E.	○
(4) The draft inducer comes up to speed and establishes combustion airflow, causing the normally open differential pressure air proving switch contacts to close. When combustion airflow is proved, Lamp B is illuminated indicating that the 15 second pre-purge cycle has begun.	A.	●
	B.	●
	C.	○
	D.	○
	E.	○
(5) After the pre-purge has completed, Lamp B is extinguished and Lamp C is illuminated, indicating power is being delivered to the hot surface igniter for the 20 second igniter warm-up period. The bright yellow-orange glow of the hot surface igniter can be observed through the observation port on the boiler.	A.	●
	B.	○
	C.	●
	D.	○
	E.	○
(6) After the igniter warm-up period the integrated boiler control energizes the gas valve, initiating a 6 second trial for ignition mode which is indicated by the illumination of Lamp D. Two seconds later, Lamp C will extinguish when the integrated boiler control stops sending power to the hot surface igniter.	A.	●
	B.	○
	C.	●
	D.	●
	E.	○
(7) A low level illumination of Lamp E indicates the initiation of flame proving. During the last 2 seconds of the trial for ignition mode, main burner flame is proven by flame rectification through the hot surface igniter, providing a flame signal that is relayed to the integrated boiler control, fully illuminating Lamp E.	A.	●
	B.	○
	C.	○
	D.	●
	E.	●
(8) The thermostat ends its call for heat, causing the integrated boiler control to de-energize the gas valve and system circulator. Lamp D is extinguished while the unit enters the 30 second post purge mode, indicated by the illumination of Lamp B. Lamp E will remain illuminated as the remainder of the gas in the blower is burned off (approximately 2 seconds). During post purge the blower remains powered and clears out any residual products of combustion.	A.	●
	B.	●
	C.	○
	D.	○
	E.	○
(9) After the post purge mode the draft inducer is de-energized and the unit goes into standby mode until the next call for heat from the thermostat.	A.	●
	B.	○
	C.	○
	D.	○
	E.	○

NOTE: The first one or two cold starts may be rough due to the gas line not being completely purged of air, causing low firing rate and high excess air levels.

XIII. CHECKOUT PROCEDURE & ADJUSTMENTS

INSPECT VENTING & AIR INTAKE SYSTEM

Operate the boiler and verify that all vent/air intake connections are gastight and watertight. Repair any leaks immediately.

INSPECT CONDENSATE DRAIN

Verify that all connections are watertight, and that condensate flows freely. Repair any leaks immediately.

INSPECT SYSTEM PIPING

Verify that all connections are watertight. Repair any leaks immediately.

TEST IGNITION SYSTEM SAFETY SHUTOFF

1. Turn off manual gas shut off valve.
2. Set thermostat to call for heat.
3. Boiler begins normal sequence of operation.
4. After approximately 30 seconds (pre purge and igniter warm-up period), lamp D illuminates, indicating gas valve is powered.
5. After 4 seconds, gas valve closes, lamp D goes out as integrated boiler control senses that flame is not present.
6. To restart system, follow operating instructions in Section XII, "Start Up."

TEST AND ADJUST HIGH LIMIT CONTROL

Set high limit differential to minimum setting. While burner is operating, adjust setting on high limit control below actual boiler water temperature. Burner should go off while circulator continues to operate. Raise limit setting above boiler water temperature and burner should reignite after pre purge and igniter warm-up period. Set the high limit control to the design temperature requirements of the system. Maximum high limit setting is 200°F. Minimum high limit setting is 100°F. Return high limit differential to original setting (20°F)

TEST OTHER SAFETY CONTROLS

If the boiler is equipped with a low water cut off, a manual reset high limit, or additional safety controls, test for operation as outlined by the control manufacturer. Burner should be operating and should go off when controls are tested. When safety controls are restored, burner should reignite.

SET THERMOSTAT HEAT ANTICIPATOR (if used) AND VERIFY THERMOSTAT OPERATION

For a single thermostat connected to the yellow thermostat lead wires in the furnished field wiring junction box, the heat anticipator should be set at 0.7 amps. For other wiring configurations, refer to the instructions provided by the thermostat manufacturer regarding adjustment of heat anticipator. Cycle boiler with thermostat. Raise the thermostat to the highest setting and verify boiler goes through normal start up cycle. Lower thermostat to lowest setting and verify boiler goes off.

MEASURE NATURAL GAS INPUT RATE

Correct input rate is essential for proper and efficient operation of the burner and boiler.

1. Determine the elevation at the installation site.
2. See Table 2 in Section IV of this manual to determine the correct approximate input rate for the local elevation.
3. Obtain the yearly average heating value of the local gas utility. At sea level elevation, it should be approximately 1000 BTU per standard cubic foot.
4. Operate boiler for 5 minutes.
5. Turn off all other gas appliances, extinguishing standing pilots where applicable.
6. At the gas meter, measure the time in seconds required to use one cubic foot of gas.
7. Calculate the "input rate" according to the following formula:

$$\text{Btuh Input Rate} = \frac{3600 \times \text{Heating Value From Step 3}}{\text{Time In Seconds From Step 6}}$$

8. The measured input rate should be within +0/-2% of the input rating found in step 2. If not, see "Adjustments and Checkout" on next page.

XIII. CHECKOUT PROCEDURE & ADJUSTMENTS

ADJUSTMENTS AND CHECKOUT

It is important that this appliance operate between 8.5 and 10% CO₂. To verify that the appliance is operating in this range, follow the steps below.

Important: Under all conditions CO levels should not exceed 100ppm.

1. Check incoming gas pressure to the appliance using a pressure gauge with a resolution of 0.1" w.c. or better and a range from 0" to at least 14" w.c. Close the gas shut-off inside the boiler jacket. Locate the inlet pressure tap on the gas valve (see **Figure #15** in Section XI). Open the inlet pressure tap screw ½ turn and connect the positive side of the pressure gauge to the inlet pressure tap. Open the gas shut-off. The gas pressure should read between 4" and 10" w.c. for natural gas and between 10" and 14" w.c. for propane gas.
2. Drill a hole in the plastic CPVC vent pipe or exhaust tee, just large enough to allow access for the sample probe of your combustion analyzer.
3. Turn the thermostat to the closed position so the appliance is activated.
4. Allow the appliance to run for approximately 5 minutes.
5. Insert the sample probe of your combustion analyzer into the hole you drilled in step 2 above, about halfway into the exhaust gas stream. Take a flue gas reading and observe the CO₂ value. Adjust the throttle screw until the CO₂ value is between 8.5 and 10%. (O₂ between 5.5% and 2%) Turning the throttle screw counterclockwise increases the rate and the CO₂ value. Turning the throttle screw clockwise decreases the rate and the CO₂ value. Allow the appliance to stabilize for approximately 1 minute after adjusting the throttle screw before you take a reading with your combustion analyzer.
6. After adjustments are made stop the appliance, disconnect the pressure gauge, tighten the inlet pressure tap on the gas valve, remove the CO₂ meter from the CPVC pipe, and seal the hole with an appropriate material.
7. Return the thermostat switch to its original position.

FINAL CHECKOUT OF THE INSTALLATION

After any adjustment to the appliance, observe several complete cycles to ensure that all components function correctly.

SET THERMOSTAT TO DESIRED TEMPERATURE

Set thermostat to desired room temperature and observe several complete cycles to verify proper operation.

FINAL REVIEW AND SIGN-OFF

Review all instructions shipped with this boiler with owner or maintenance person. Instructions must be affixed on or adjacent to the boiler. Then complete and sign the "Installation and Checkout Certificate" at the end of this manual.

XIV. MAINTENANCE AND CLEANING

Maintenance as outlined below can be performed by the owner unless otherwise noted.

The acidic nature of flue gasses condensing on the aluminum boiler sections will cause the formation of aluminum oxide. This oxide formation is normal, is generally uniform throughout the boiler sections, and represents a negligible mass of aluminum that is consumed by oxidation during the life of the boiler. If left unchecked, this buildup may eventually cause blockage of the flue gas passages in the boiler sections, reducing efficiency, and ultimately shutting down the boiler due to lack of combustion air flow. ***Regular service and maintenance by a qualified service agency must be performed to assure safe trouble free operation and maximum efficiency. It is recommended to service the appliance at least once every 12 months.***

BEGINNING OF EACH HEATING SEASON

1. Schedule an annual service call by a qualified service agency, which includes:
 - a. Examine flue passages between boiler sections, burner, and condensate lines, and clean if necessary following the annual examination and cleaning instructions in paragraph F (below).
 - b. Visually inspect venting and air intake system for proper operation. If the vent or air intake show any signs of deterioration or leakage, repair or replace them immediately. Insure proper reassembly and resealing of the vent and air intake system.
 - c. Check for and remove any obstruction to the flow of combustion air or venting of flue gases.
 - d. Follow instructions for “*Placing Boiler In Operation*” in Section XII of this manual.
 - e. Follow “*Checkout Procedures and Adjustments*” on previous page.
 - f. Visually inspect condensate drain line for proper operation. Check for deteriorated or plugged condensate drain line.
 - g. Check all gasketed joints for leakage, and tighten bolts or replace gaskets if necessary.
 - h. Remove jacket front and top panels and check for piping leaks around relief valve and other fittings. Repair, if found. DO NOT use stop leak compounds.

2. Check that boiler area is free from combustible materials, gasoline, and other flammable vapors and liquids.
3. Circulator pump and blower motor furnished with boiler are permanently lubricated from the factory and require no further lubrication. Additional or non-factory supplied pumps and/or motors should be lubricated according to the pump and/or motor manufacturer’s instruction.

DAILY DURING HEATING SEASON

1. Check for and remove any obstruction to the flow of combustion air or venting of flue gases.
2. Check that boiler area is free from combustible materials, gasoline, and other flammable vapors and liquids.

MONTHLY DURING HEATING SEASON

1. Remove jacket front and top panels and check for piping leaks around relief valve and other fittings. If found, contact a qualified service agency to repair. DO NOT use stop leak compounds.
2. Test relief valve. Refer to valve manufacturer’s instructions packaged with relief valve.
3. Visually inspect venting and air intake system for proper function. If the vent or air intake show any signs of deterioration or leakage, contact a qualified service agency to repair or replace them immediately and to insure proper reassembly and resealing of the vent and air intake system.
4. Visually inspect the PVC condensate drain pipe for proper operation. If the drain pipe shows any signs of blockage, leakage, or deterioration contact a qualified service agency to clean, repair, or replace it immediately.
5. Check air vent(s) for leakage.

PERIODICALLY DURING HEATING SEASON

Where low water cut offs are used, a periodic inspection of the low water cut off is necessary, including flushing of float type devices. Refer to low water cut off manufacturer’s specific instructions.

XIV. MAINTENANCE AND CLEANING

ANNUAL SHUT DOWN PROCEDURE (End Of each heating season)

1. Follow the instructions in “To Turn Off Gas To Appliance” in Section XII.
2. If heating system is to remain out of service during freezing weather, and does not contain antifreeze, drain system completely. If boiler will be exposed to freezing temperatures, drain condensate lines. Otherwise, do not drain system or boiler.

ANNUAL EXAMINATION AND CLEANING OF BOILER COMPONENTS

The following service procedures must be performed only by a qualified service agency. Boiler owner should not attempt these procedures.

1. Before servicing, turn off electrical power to boiler at service switch. Close manual gas valve to turn off gas supply to boiler.
2. Examine flue passages by removing blower assembly from casting as shown in the separately provided “Repair Parts Manual.” The procedure for examining and cleaning the burner is described below.

Any buildup of sediment or aluminum oxide (white powdery or flaky substance) in the flue passages must be cleaned as follows:

- a. Remove jacket front and top panels.
- b. Confirm that manual gas valve is closed and disconnect gas line to gas valve at union.
- c. Disconnect wires to gas valve and igniter.
- d. Remove air inlet assembly from gas valve.
- e. Loosen but do not remove five nuts attaching blower adapter assembly to boiler.
- f. Remove two igniter screws and very carefully remove the igniter. **The igniter element is very sensitive. Do not touch the igniter element with your fingers or hands as oils or debris will cause premature failure.**
- g. Remove five nuts and blower adapter assembly. Remove burner and gaskets.
- h. Aluminum oxide deposits are water soluble and may be rinsed away with spraying or running water.
- i. Use a flexible handle nylon brush to loosen sediment and aluminum oxide on all exposed

heating surfaces of boiler (see “Repair Parts Manual” for diagram). **Be sure that brush does not get stuck in heat exchanger!**

- j. After brushing and rinsing, remove any remaining loosened sediment using a shop vacuum with a snorkel attachment.
 - k. Inspect burner for any foreign matter in the flame ports or inside the burner. Any foreign matter should be removed by blowing with compressed air or vacuuming.
 - l. Reinstall burner and gaskets and position blower adapter assembly over studs. Install five nuts but do not tighten. Reinstall igniter and igniter gasket and fasten with two screws. **The igniter element is very sensitive. Do not touch the igniter element with your fingers or hands as oils or debris will cause premature failure** Tighten five nuts holding blower adapter assembly.
 - m. Connect gas line to gas valve; air inlet assembly to gas valve (using 2” x 1½” flexible coupling); pressure switch hose to gas valve and air inlet assembly; 2” flexible coupling to boiler exhaust port; igniter wires; and gas valve wires.
3. Visually inspect the condensate trap. Refer to repair parts diagrams. Any foreign material or debris that is visible in the condensate lines needs to be cleaned out as described below.
 - a. Inspect for sediment or blockage.
 - b. Flush out with water or vacuum.
 - c. Follow the instructions under “Near Boiler Piping” in Section XII for filling condensate trap with water.
 4. Inspection of the flue connector requires the following steps. Refer to the “Repair Parts Manual” for diagram.
 - a. Loosen clamp on draft inducer end of 2” flexible coupling that connects vent tee to exhaust port.
 - b. Inspect interior of vent tee. Any buildup of sediment on the inside surface must be cleaned.
 - c. Reconnect the 2” flexible coupling to the draft inducer outlet.

DETAILED SEQUENCE OF OPERATION

SERVICE HINTS

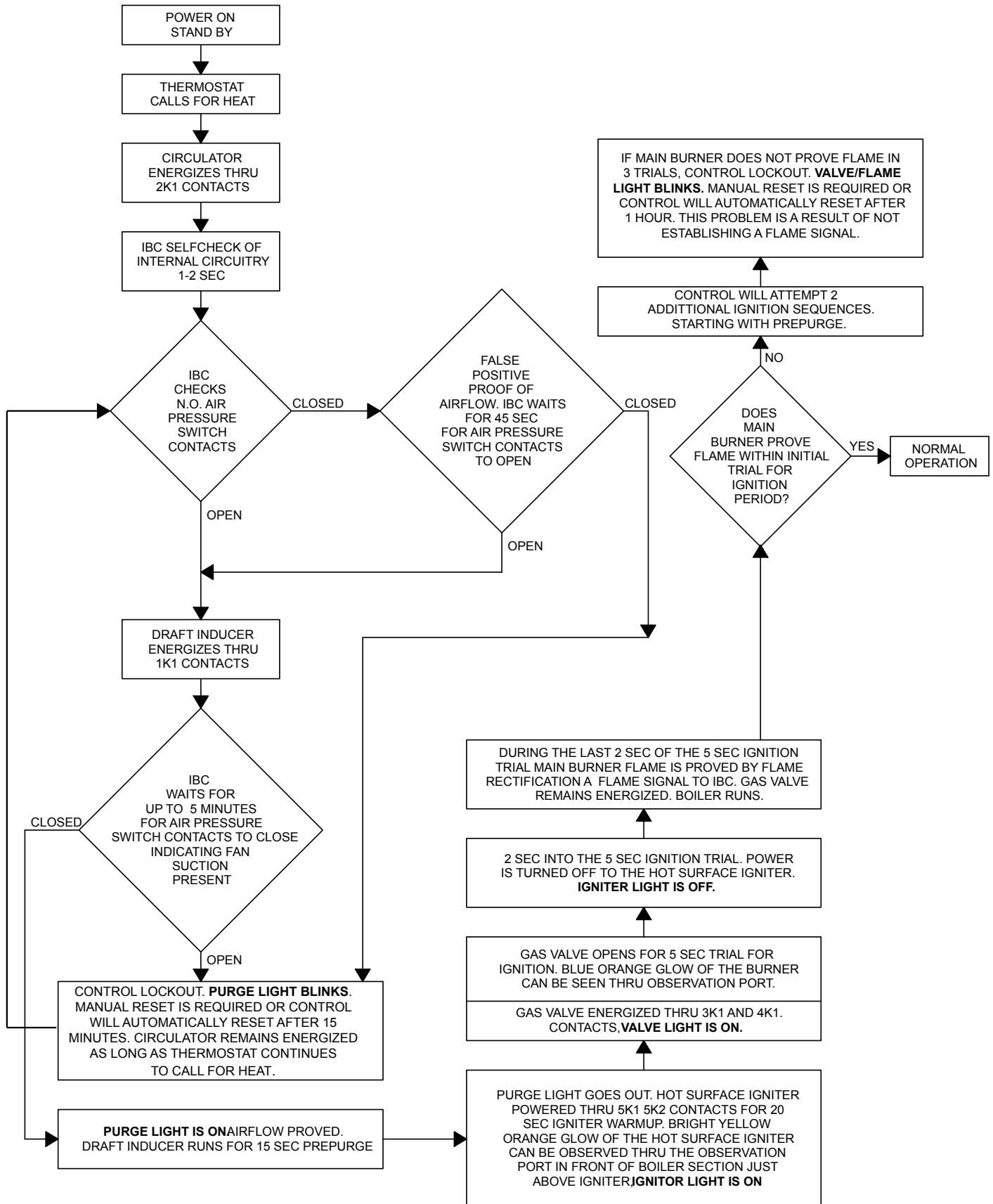

DETAILED SEQUENCE OF OPERATION

SAFETY SEQUENCES DURING OPERATION

DRAFT INDUCER TEMPERATURE SAFETY SWITCH

If draft inducer temperature reaches temperature safety switch setpoint, safety switch contacts open immediately, closing gas valve (*light goes out*).

Draft inducer runs through 30 second post purge and switches off.

Circulator runs with thermostat on call for heat.

When temperature safety switch contacts remake before end of call for heat, control goes into normal light-off sequence.

CASTING TEMPERATURE SAFETY SWITCH

If burner operates when boiler has no water, aluminum boiler sections heat up rapidly.

Casting temperature safety switch contacts will open, breaking 24 volt power to ibc. power indicator light goes out. Requires manual reset to re-close contacts. **Power light goes out.**

LOSS OF FLAME SIGNAL

If an established flame signal is lost while control expects that the burner is operating, control will immediately de-energize gas valve. **Valve and flame lights go out.**

Draft inducer runs through 30 second post purge.

Control will attempt to relight boiler 3 times. If flame is not proven, control lockout - problem establishing a flame signal. **Valve light is blinking.** Control will automatically reset after 1 hour.

HIGH LIMIT CONTROL

If boiler water temperature reaches high limit (aquastat) setpoint, high limit n.c. contacts open immediately, closing gas valve. **Valve and flame lights go out.**

Draft inducer continues to run for 30 second post purge and switch off.

Circulator runs as long as thermostat calls for heat.

When high limit contacts remake before end of call for heat - control goes into a normal light-off sequence.

LOSS OF COMBUSTION AIRFLOW

If combustion airflow is lost while burner is firing (Differential air pressure switch contacts open) gas valve will be de-energized. **Valve and flame lights go out.**

Draft inducer runs through 30 second post purge.

If call for heat remains, ibc waits 5 minutes for airflow to be re-established.

If airflow does not re-establish control lockout - problem with combustion airflow. **Purge light blinks.** Control will automatically reset after 15 minutes.

CIRCULATOR PUMP

Circulator will be energized as long as thermostat calls for heat during lockout.

Recovery from any lockout requires reset, which can be accomplished by:

- (a) Removing and reestablishing the thermostat's call for heat or turning the service switch off and back on; or
- (b) Waiting for the control to automatically reset after 15 minutes for loss of combustion airflow or one hour for loss of flame.

DETAILED SEQUENCE OF OPERATION

END OF NORMAL SEQUENCE OF OPERATION

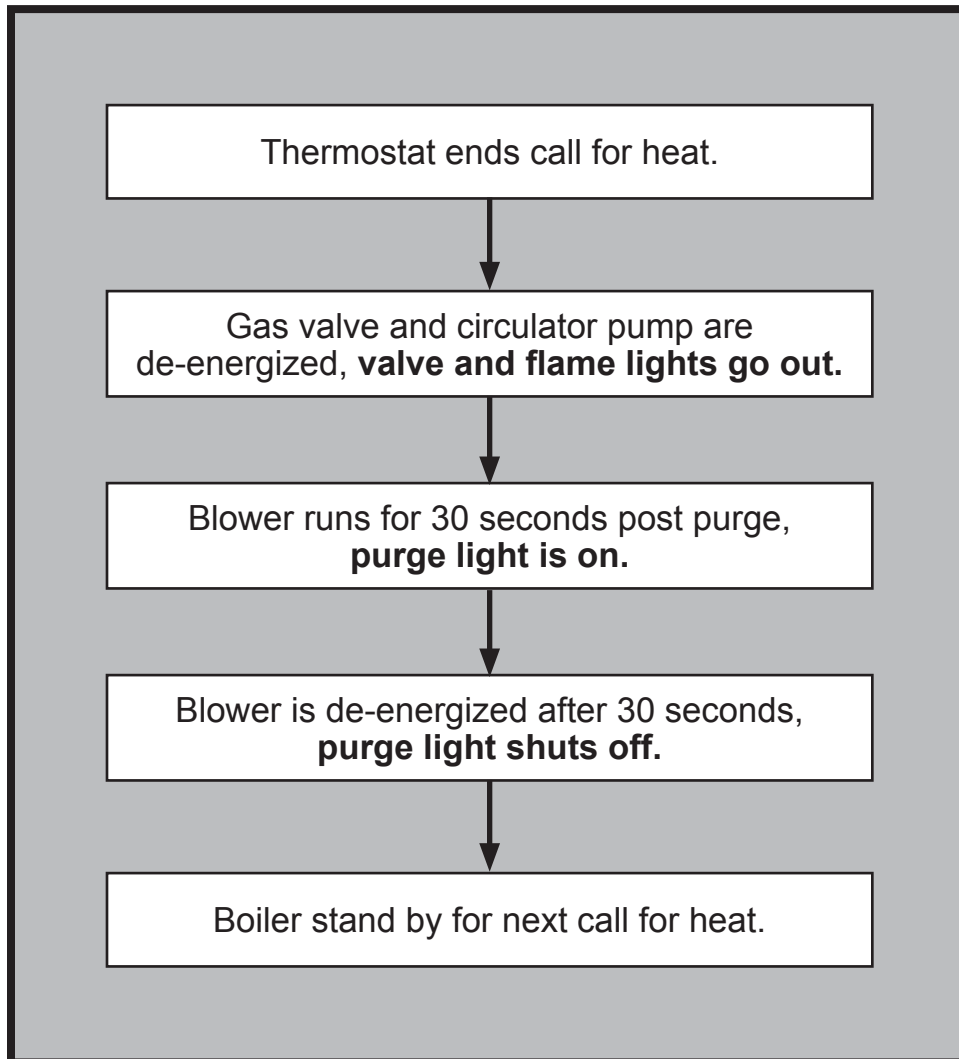

TROUBLESHOOTING

DANGER

Fire, Explosion or Shock Hazard may cause Property Damage, Sever Injury or Death. DO NOT ATTEMPT TO MODIFY THE PHYSICAL OR ELECTRICAL CHARACTERISTICS OF THIS BOILER IN ANY WAY.

IMPORTANT

1. In a reset from lockout condition, all electrical meter readings at the gas control valve (24 VAC) **must** be taken within the trial for ignition period.
2. If any component dose not function properly, make sure it is correctly installed and wired before replacing it.
3. Static electricity discharge can damage the integrated boiler control (IBC). Touch metal surface to discharge static electricity before touching IBC.
4. **THE IBC CANNOT BE REPAIRED.** If it malfunctions it must be replaced.
5. Only trained, experienced service technicians should service the IBC systems, by following the *Troubleshooting, Check Out The System and the Sequence Of Operation* section of this chapter for the normal Light Off Sequence.
6. All controls are factory tested in the assembly process. A defective control is generally the least likely cause of malfunction. If you suspect the unit has a defective control, read through the troubleshooting chart before replacing it.
7. It is extremely unlikely that two consecutive controls are defective. If this seems to be the case chances are that the controls are not the cause but rather the malfunction is due to some other problem such as an electrical short burning out a transformer.

INITIAL SERVICE CHECKS

1. **Before Troubleshooting:**
 - A. Make sure that the circuit breaker is on or fuse is OK at the electrical panel.
 - B. Make sure that the service switch is ON.
 - C. Make sure that the Gas is ON at the:
 - Gas meter
 - All appropriate manual shutoff valves
 - Gas control valve
 - D. Make sure that the thermostat is calling for heat.
 - E. Make sure that the wire connections at the integrated boiler control and at the originating control are securely plugged in or connected.
 - F. Check that the hoses are securely connected and are not plugged or damaged.
2. **Troubleshooting Tools:**
 - A. Voltmeter to check 120 VAC and 24 VAC
 - B. Continuity Tester
 - C. Inclined Manometer or Pressure Gauge with 0-2.0" range (0.01" scale) for measuring suction pressures at the pressure switch.
 - D. U-Tube Manometer or Differential Pressure Gauge with 0-14" range (0.1" scale) for measuring inlet and manifold gas pressures.
3. **What Is The System Status?**
 - A. Consult the chart on the following page.
 - B. **Figure #15** shows the location of the Diagnostic Indicator Lamps on the boiler.

TROUBLESHOOTING

SYSTEM STATUS

The indicator lights track the operating sequence. If the system locks out, the lights indicate the point in the sequence of operation where lockout occurs. If this table does not readily provide the reason for boiler malfunction or non-operation, refer to the following pages for more detailed troubleshooting procedures.

LIGHT	STATUS	INDICATES
POWER	ON	IBC is energized through 24 volt transformer.
	OFF	IBC is not energized.
	Blinking	IBC receives more than 40 VAC.
PURGE	ON	IBC is energizing the draft inducer and air flow is proven.
	OFF	Off during purge cycle - draft inducer is not powered on or air flow is not proven.
		Off during igniter and run cycle - normal operation, purge cycle complete.
Blinking	IBC is locked out. Problem could indicate false positive proof of air flow. Blocked vent, intake air pipe, flue way, or orifice in negative pressure hose.	
IGNITER	ON	IBC is energizing igniter.
	OFF	Igniter is not energized.
VALVE	ON	IBC is energizing gas control valve to open.
	OFF	Gas control valve is closed.
	Blinking	IBC is locked out. Problem is flame has not been proven in three (3) ignition attempts. May be due to broken igniter or lack of/low flame signal, or no gas.
FLAME	On Bright	Flame proven.
	On Dim	Checking for flame signal (during trial for ignition)
	OFF	Flame unproven.

TROUBLESHOOTING CHART 1

! WARNING

***ELECTRICAL SHOCK HAZARD
MAY CAUSE SERIOUS INJURY OR DEATH***

The following procedures may expose you to dangerous line voltage. Use caution to avoid touching live electrical contacts. Service must be performed by a trained, experienced service technician.

WHAT TO DO IF YOU SMELL GAS

- Do not try to light any appliance.
- Do not touch any electric switch or use any phone in the building.
- Immediately call your gas supplier from a neighbor's phone. Follow the gas supplier's instructions.
- If you can not contact your gas supplier, call the fire department.

Should overheating occur or the gas supply fail to shut off, do not turn off or disconnect the electrical supply to the pump. Instead, shut off the gas at a location external to the appliance.

Do not use the boiler if any part of the gas control system has been under water. A qualified service technician should inspect the boiler and replace any part of the control system and any gas control which has been under water.

Use only your hand to turn the gas control knob. Never use tools. If the knob will not turn by hand, don't try to repair it. Force or attempted repair may result in a fire or explosion.

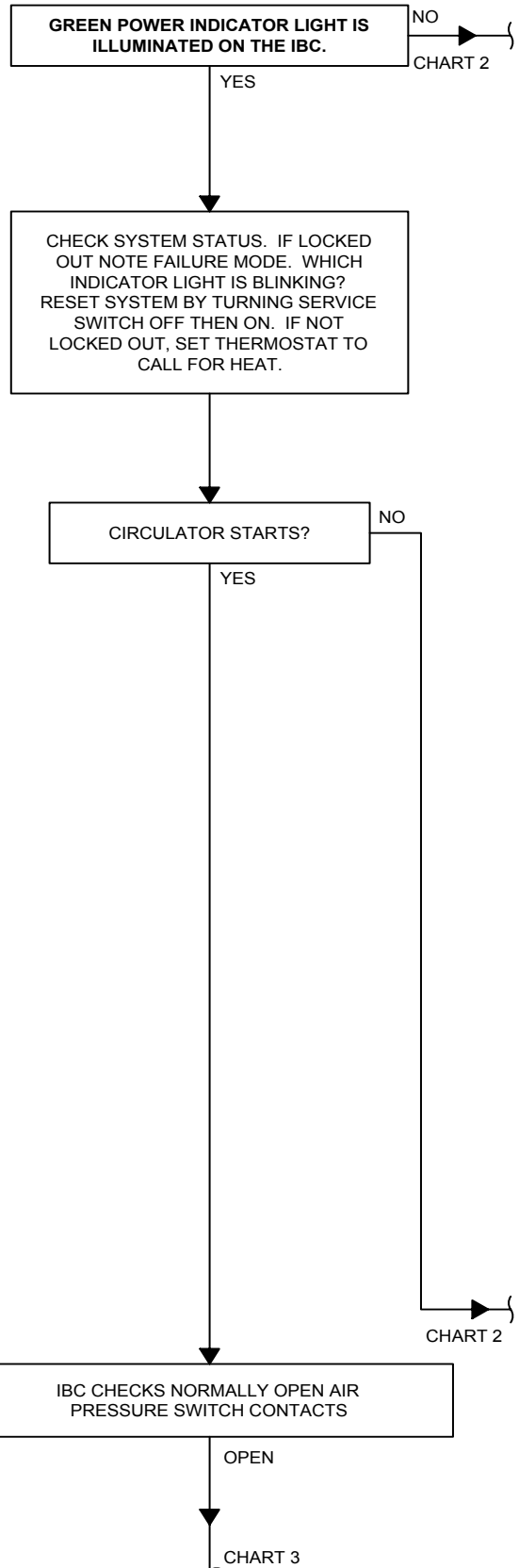

FALSE POSITIVE PROOF OF AIRFLOW. CHECK AIR PRESSURE SWITCH CONTACTS. IF CONTACTS ARE CLOSED WITH NO AIRFLOW, REPLACE PRESSURE SWITCH.

CLOSED

IBC CHECKS NORMALLY OPEN AIR PRESSURE SWITCH CONTACTS

OPEN

CHART 3

TROUBLESHOOTING

TROUBLESHOOTING CHART 2

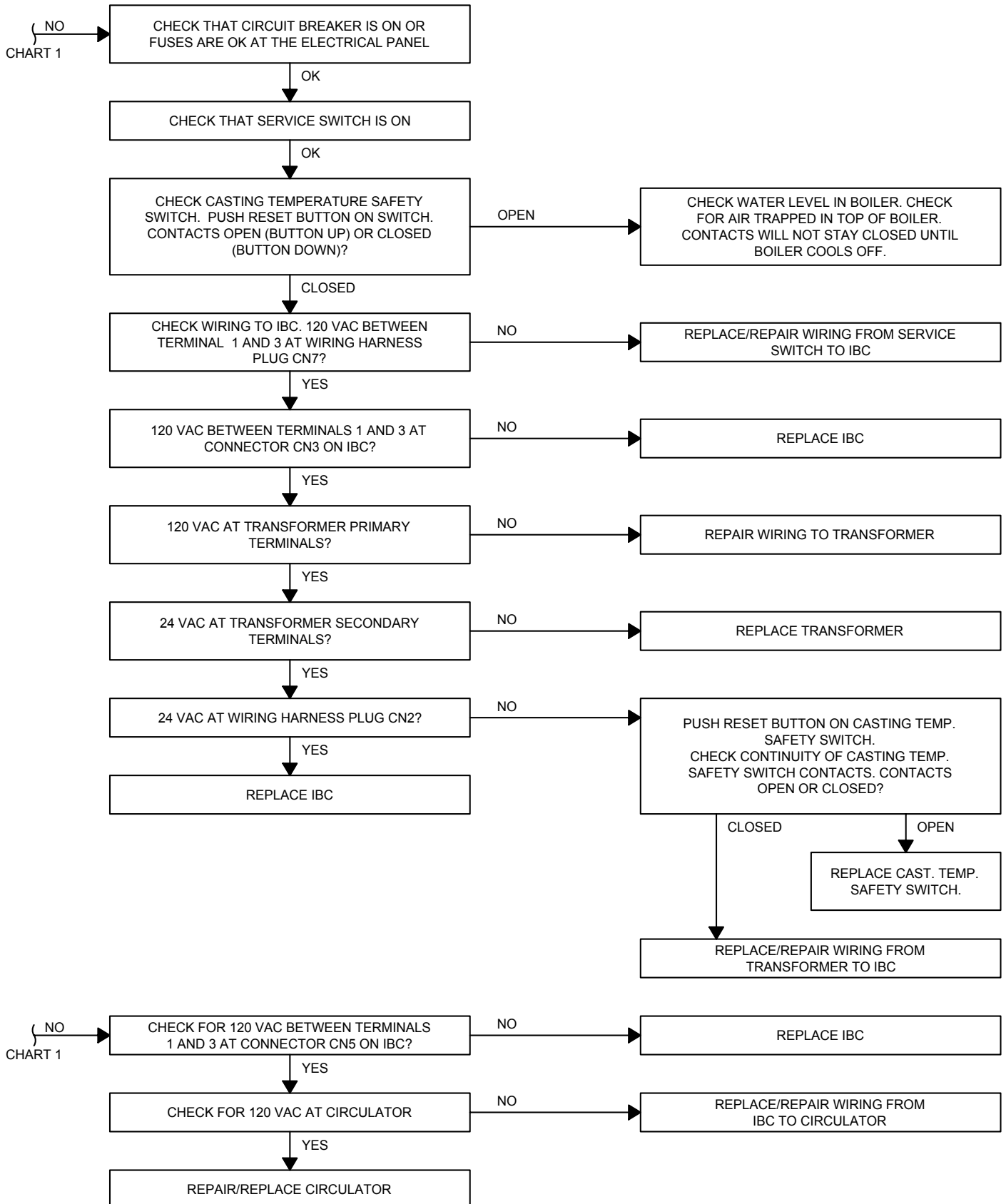

TROUBLESHOOTING

TROUBLESHOOTING CHART 3

CHART 1
OPEN

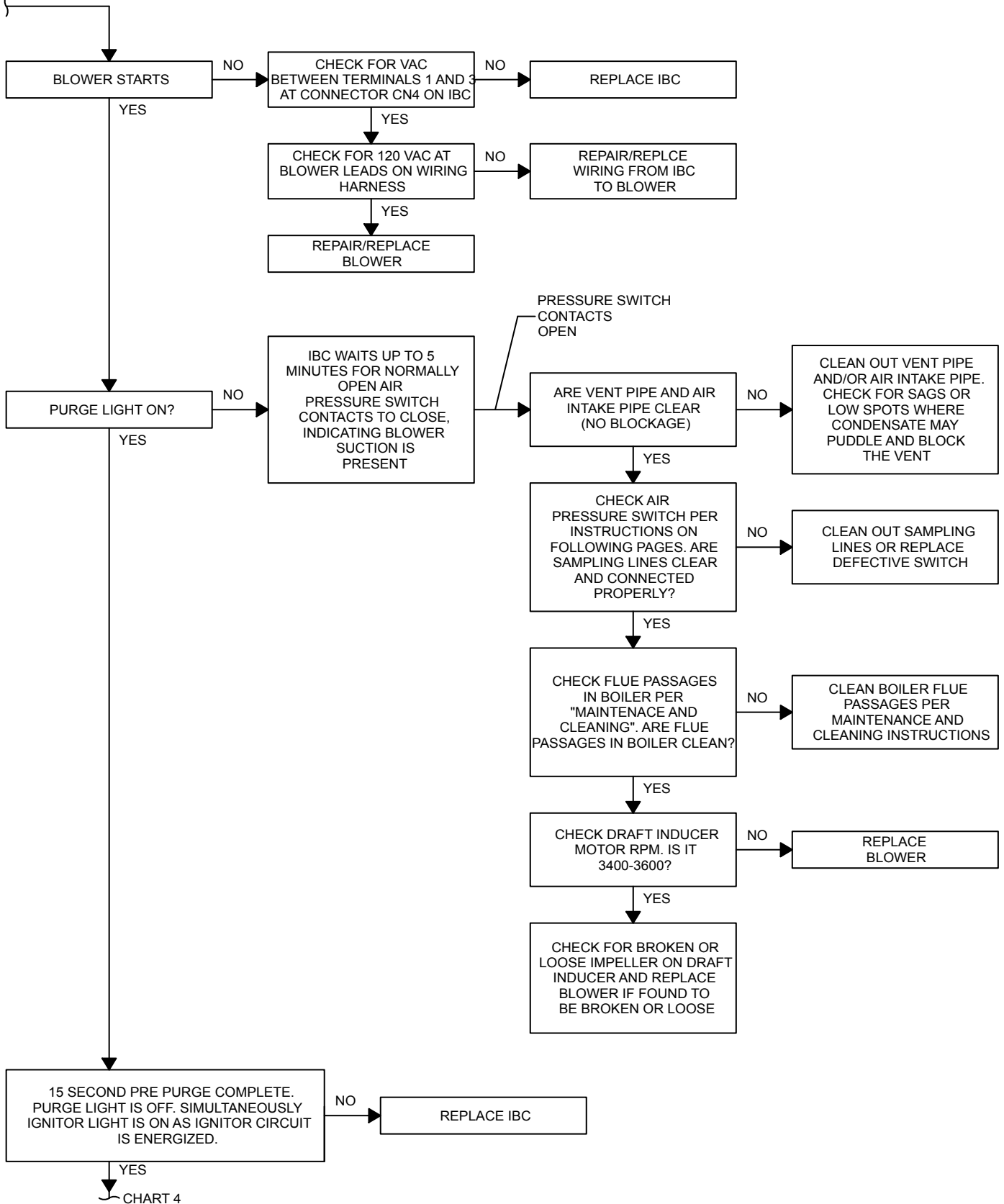

TROUBLESHOOTING

TROUBLESHOOTING CHART 4

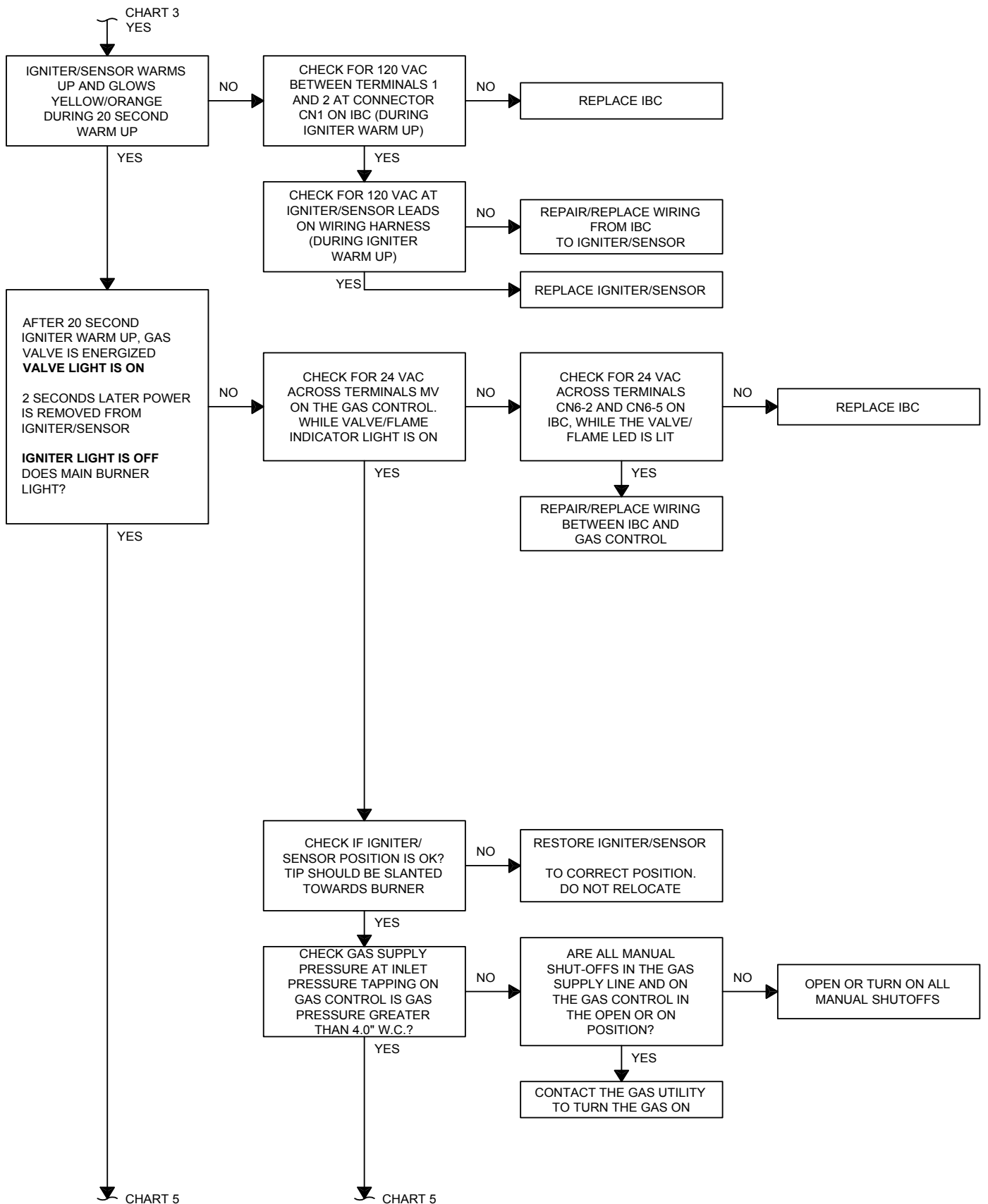

TROUBLESHOOTING

TROUBLESHOOTING CHART 5

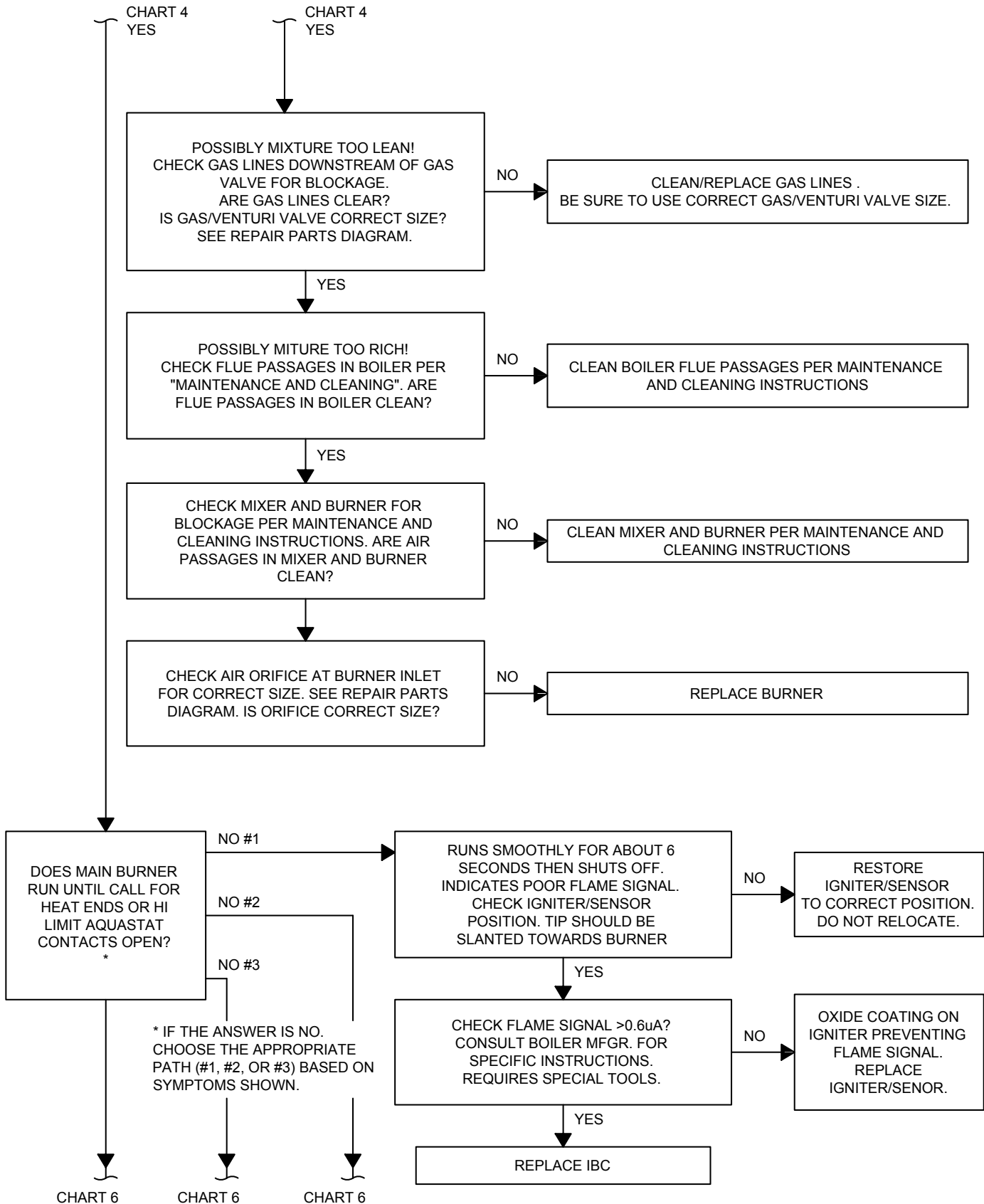

TROUBLESHOOTING

TROUBLESHOOTING CHART 6

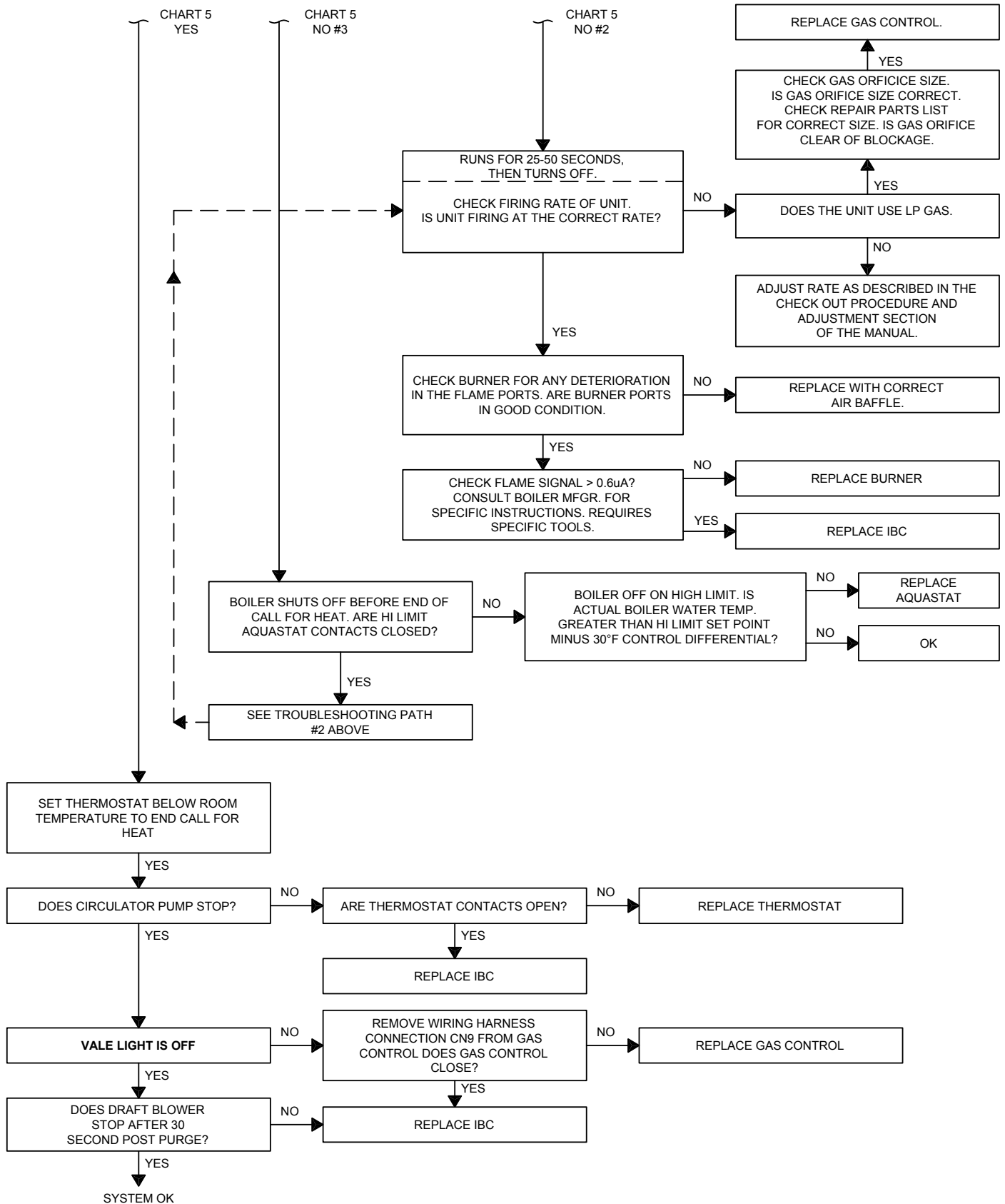

TROUBLESHOOTING

DIFFERENTIAL AIR PRESSURE SWITCH CHECK

The differential air pressure switch is a safety device which will prevent the boiler from firing if there is an air intake, boiler heat exchanger or vent blockage.

The following steps and diagram indicate the location of the connection points required to measure the offset pressure using an Inclined Manometer or a Differential Pressure Gauge. *Only one device is required to measure the offset pressure.*

1. Turn off service switch, or lower thermostat setting.
2. Remove vinyl caps from Tee.
3. Install testing lines as shown to Inclined Manometer or Differential Pressure Gauge with the ability to read 0.01" to at least 6.0" w.c.
4. Turn on service switch and set thermostat to call for heat.
5. If manometer readings do not correspond to the chart at right, check for possible causes:
 - Blockage or moisture in suction lines to switch.
 - Blockage or moisture in orifice installed in suction lines to switch.
 - Blockage in air intake or vent pipes.
 - Undersized air intake or vent pipes.
 - Loose blower wheel on motor shaft.
 - Incorrect pressure switch or pressure switch setpoint.
 - Gas valve out of adjustment.
6. When the pressure reading corresponds to the chart at right and the pressure switch is operating properly, remove the testing lines and reinstall the vinyl caps to the Tee and 3-way connector.

Locations of the connection points required to check the differential air pressure.

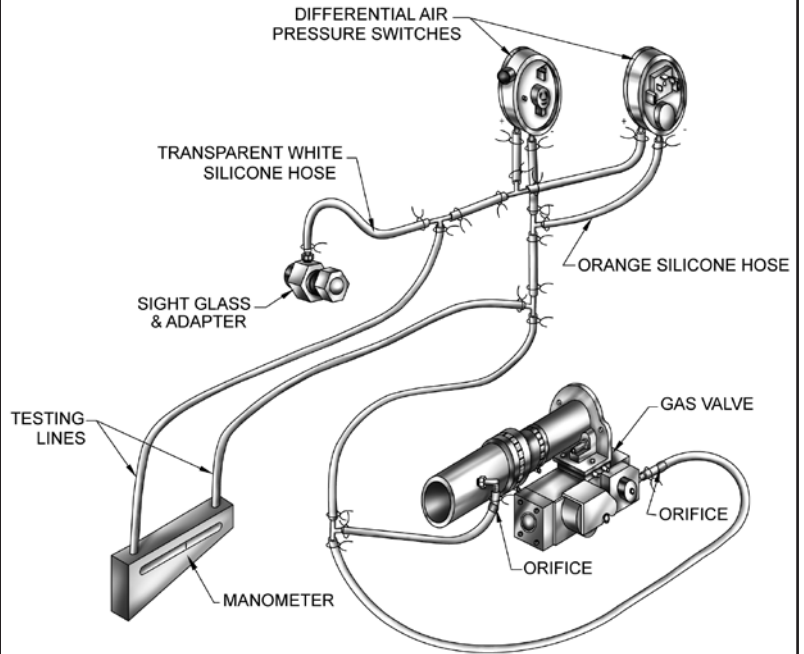

Boiler Status	Differential Pressure	Switch	Contacts
Not Running	0"	3.5" 0.5"	Closed Open
Running Without Blockage (Approximate minimum vent lengths)	1.00" for Model 125	3.5"	Closed
	1.50" for Model 150 1.50" for Model 175 2.00" for Model 200	0.5"	Closed
Running With Blockage	Greater Than or Equal To Setpoints	3.5"	Open
		0.5"	Closed

INSTALLATION AND CHECK-OUT CERTIFICATE

Boiler Model _____ Serial # _____ Date Installed _____

Measured BTU/HR input _____

- Installation instructions have been followed
- Checkout procedure and adjustments performed
- Maintenance and Service issues reviewed with owner/ maintenance person
- Installation booklet affixed on or adjacent to boiler

Installer (Company) _____

Address _____

Phone _____

Installer's Name _____

Signature _____

