

QUANTUM 90

NATURAL OR PROPANE
GAS-FIRED BOILERS



Dunkirk[®] 
America's Hottest Boiler Value!

An ISO 9001-2000 Certified Company



QUANTUM 90

NATURAL OR PROPANE GAS-FIRED BOILERS

The Quantum 90 Hot Water Boiler by Dunkirk achieves an optimum combination of high efficiency, innovative technology, and simplicity of design, making it the ideal choice for today's heating customer.

Remarkable 90% AFUE Efficiency

The Q90 dramatically reduces fuel consumption and *pays for itself* with substantial annual fuel savings. Its efficiency is increased beyond 90% when used in low temperature systems, such as radiant systems.

Revolutionary Cast Aluminum Heat Exchanger

Transfers heat *three times faster* with greater thermal conductivity than conventional cast iron. It produces enormous gains in heat-up speed and operating efficiency. Also, the packaged boiler weighs **only 256 pounds** for easier installation.

Safe, Economical CPVC and PVC Vent Pipe

Cooled flue gas can be safely vented through inexpensive readily available and easy to install PVC, after 5' of CPVC provided with the unit. The air intake also utilizes PVC pipe.

Sealed Combustion, Direct-Vent System

Unlike conventional residential atmospheric and induced draft boilers, the Q90 draws fresh air from outdoors for combustion, instead of air from inside the home. Therefore it does not compete with building occupants for its air supply. With this design the Q90 runs quieter than a traditional boiler.

Simplified Controls

The Quantum 90's simple design is engineered to maximize reliability. The Q90 incorporates an integrated boiler control for operation, safety and diagnostics. A High Temperature Limit Control is included for additional safety. Ignition is provided by a hot surface ignitor and a single stage gas valve. A single pressure switch ensures air intake and exhaust vents are clear. All components are easily accessible through the removable door.

Environmentally Friendly

The Q90's direct-vent system, premix gas burner and low flame temperature substantially reduce CO and NOx emissions (acid rain and smog components).



Ideal for Use with Radiant Systems

When used in combination with radiant systems, which use low supply and return water temperatures, the Q90's efficiency is increased beyond 90%. Unlike cast iron boilers, the Q90 does not require a return bypass or injection pumping system to preheat return water prior to entering the heat exchanger. This saves on material and labor costs since the cast aluminum heat exchanger works best at low water temperatures.

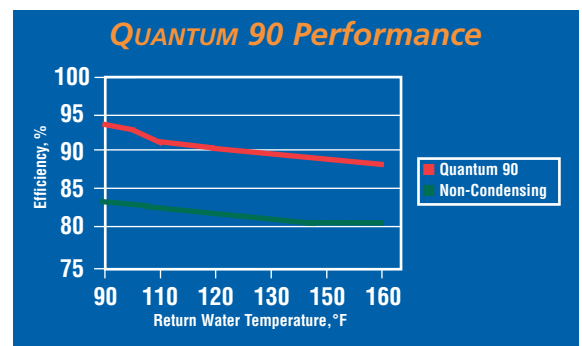

FEATURES & BENEFITS

Easy Maintenance

A compact and lightweight baked enamel steel jacket with removable door, allows easy access to controls.

Cast Aluminum Heat Exchanger

Revolutionary heat exchanger transfers heat **Three Times Faster** than cast iron. Also receives low return water without the need for bypass or injection pumping.

CPVC/PVC Pipe

Cooled flue gas is expelled through 5' of CPVC (provided) and then transitions to PVC.

Pressure Switch

A single switch ensures combustion air intake and exhaust vents are clear.

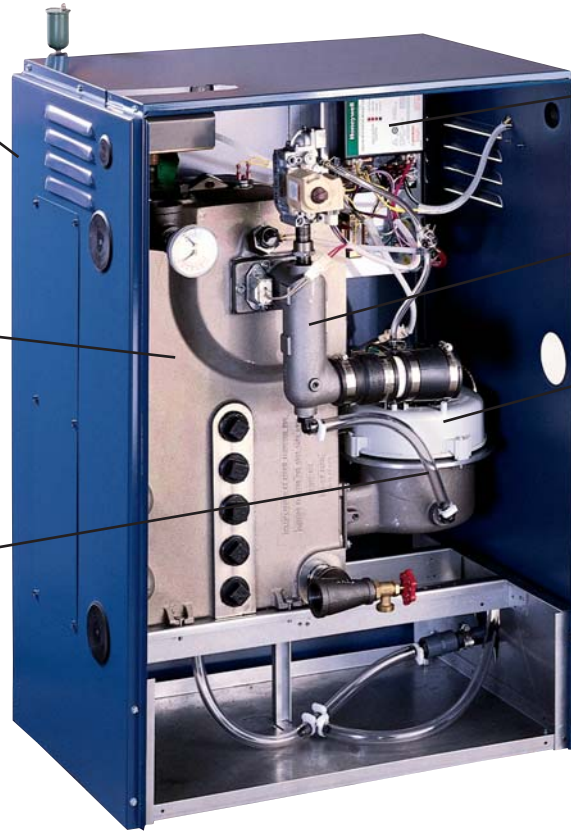

Integrated Boiler Control

The operating sequence is checked by a self diagnostic control system to ensure safe operation of the boiler.

Air/Fuel Mixer

Optimizes combustion for greater efficiency.

Induced Draft Fan

Draws fresh air from outside, in addition to expelling flue gas.

Supply-Side Pumping

The Pump is shipped prepared to be mounted for supply-side pumping. The circulator is pre-wired and comes with a 5' BX cable connector.

Electronic Low Water Cut Off now available to meet the latest codes requirements.

FULL PORT ISOLATION VALVE



Full Port Isolation Ball Valves offer a full 1-1/4" passage to maximize boiler water flows. An exterior handle clearly indicates the valve position. The ball valves allow the boiler piping to be switched from threaded pipe to copper piping, without the need for additional fittings, saving the installer valuable time!

PAYBACK

Quantum 90..... 90% AFUE

Typical 20-year old Boiler.....70% AFUE

Difference in AFUE.....20%

Increased Efficiency over 70% Model....28.57%
(20% ÷ 70%)

The increased efficiency of the Q90 could save you approximately 28% on your heating bill each year... which means, if you pay \$1500 annually in fuel bills to space heat your home, you could save as much as **\$428 per year!**

Now that's payback!

ULTRA EFFICIENT ALUMINUM HEAT EXCHANGER

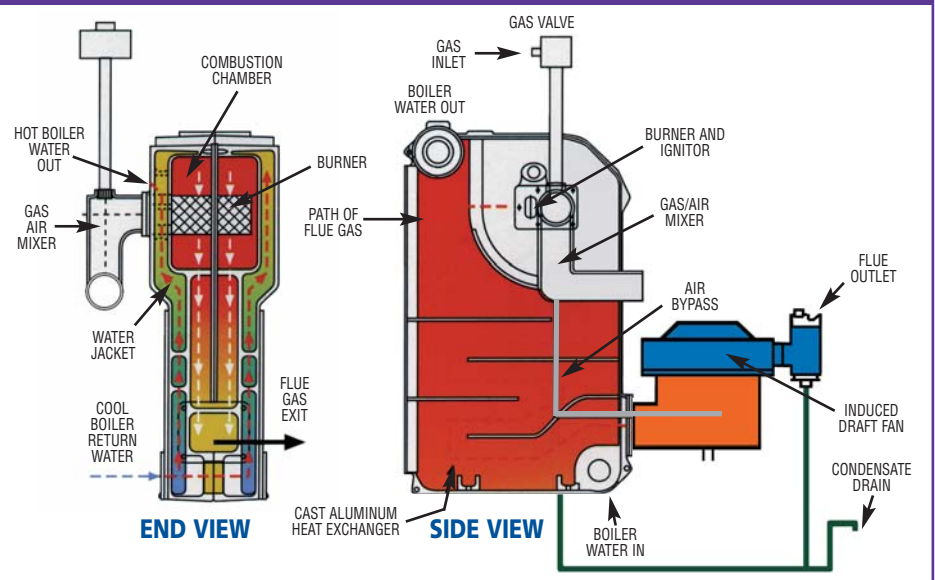

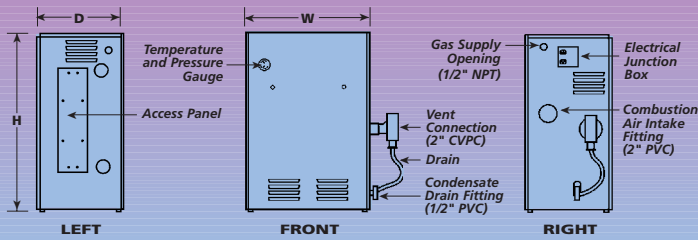

QUANTUM 90 RATINGS NATURAL & PROPANE GAS FIRED BOILERS. Ratings & Specifications for Q90 Condensing Boilers.

MODEL	INPUT (MBH)	HEATING CAPACITY (MBH)	I=B=R NET RATING (MBH)	AFUE (%)	H	DIMENSIONS - INCHES			SHIPPING WEIGHT (POUNDS)
						W	D		
Q90 - 50	50	45	39	90.0	39.5	28	19.75		256
Q90 - 75	75	68	59	90.0	39.5	28	19.75		256
Q90 - 100	100	90	78	90.0	39.5	28	19.75		256

The ratings marked "NET I=B=R RATINGS" indicate the amount of energy that can be applied to heat the radiation or terminal units. The Net I=B=R ratings shown are based on an allowance of 1.15 in accordance with the factors shown on the I=B=R Code as published by the Hydronics Institute.

Selection of boiler size should be based upon "NET I=B=R RATING" being equal or greater than the calculated heat loss of the building. Consult manufacturer before selecting a boiler for installations having unusual piping and pick-up requirements. Q90 boilers may be installed on combustible flooring.

These gas-fired boilers are design certified by C.S.A. in the United States and Canada for use with natural and propane gas. They are constructed and hydrostatically tested for a maximum working pressure of 50 psi in accordance with A.S.M.E. (American Society of Mechanical Engineers) Boiler and Pressure Vessel Code Section IV standards for heating boilers. They are capacity rated in accordance with the code of the Hydronics Institute.

SPECIFICATIONS

- GAS-FIRED, DIRECT-VENT CONDENSING HOT WATER BOILER
- May be installed on combustible flooring
- 1" clearance on all sides and top to combustible construction
- 8" clearance right side for vent/air intake pipe installation
- 24" clearance front and left side, 8" top clearance for servicing
- 0" clearance for Vent and Air Intake Pipes to combustible construction

CONNECTIONS

- 120 Volts AC, 60 Hertz, 1 Phase, Less than 12 Amps
- VENT PIPE & AIR INTAKE PIPE
 - Vent pipe - first 5' is schedule 80 2" CPVC (provided), then schedule 40 2" or 3" PVC
 - Air intake - schedule 40 2" or 3" PVC
- Water In/Out 1-1/4" NPT
- Gas In 1/2" NPT
- Condensate Drain 1/2" PVC

MEA # 218-98-E

QUANTUM 90 STANDARD EQUIPMENT

<ul style="list-style-type: none"> ■ Assembled Boiler with baked enamel finish jacket. ■ High limit aquastat. ■ Transformer. ■ 1 1/4" Taco (or Grundfos) circulator with isolation (ball) valves. ■ Temperature/pressure gauge. ■ 30 psi ASME relief valve. ■ Air vent. ■ Service Switch. 	<p><i>Completely installed and wired safety control system with burner consisting of:</i></p> <ul style="list-style-type: none"> ■ Microprocessor based Integrated Boiler Control. ■ Stainless steel premix burner. ■ Automatic gas valve. ■ Hot surface ignitor. ■ Casting and vent temperature safety switches. ■ Air flow proving switch.
---	--

15-YEAR LIMITED HEAT EXCHANGER WARRANTY.
All of our boilers are backed by Dunkirk's reputation for quality and service to customers, based on over 70 years of successful hydronic experience.

DUNKIRK QUALITY HEATING. AMERICA'S HOTTEST BOILER VALUE!
Dunkirk hydronic boilers lead the industry in value, with premium quality design and componentry. In fact, some of the most respected "brand name" boilers are produced by Dunkirk. These major manufacturers selected Dunkirk hydronic boilers for the same basic reasons you should: *superb quality* and *unmatched value*. Just compare our quality to cost ratio, and your boiler choice will become perfectly clear. Dunkirk, since 1928. America's Hottest Boiler *Value*.



Specifications and dimensions are subject to change without notice.
Made in America-by American Craftsmen

85 MIDDLE RD DUNKIRK, NY 14048
716-366-5500 FAX 866-432-7329
e-mail: heating@dunkirk.com
web site: www.dunkirk.com

USA Contractor Assistance: 800-325-5479