

INSTALLATION, OPERATION AND MAINTENANCE MANUAL

EXCELSIOR

High Efficiency
Oil Fired Hot Water Boiler



DUNKIRK BOILERS
85 Middle Road
Dunkirk, NY 14048
www.dunkirk.com

MEMBER: The Hydronics Institute

 An **ECR International Brand**
An ISO 9001-2000 Certified Company



P/N# 240007135, Rev. A [04/08]

EXCELSIOR OIL-FIRED CAST IRON HOT WATER BOILER

Model No.

DK4EXA075
DK5EXA100
DK6EXA130
DK7EXA165



**These instructions must
be affixed on or adjacent
to the boiler.**

OIL FIRED BOILERS

These boilers are low pressure, sectional cast iron boilers constructed and hydrostatically tested for a maximum working pressure of 65 psi in accordance with A.S.M.E. (American Society of Mechanical Engineers) Section IV Standards for cast iron heating boilers. They are capacity rated in accordance with the code of the I=B=R (Hydronics Institute).

! WARNING

Read all instructions carefully before starting the installation. Failure to follow these instructions exactly, may result in causing a fire or explosion, property damage, personal injury or loss of life.

PLEASE READ THIS MANUAL CAREFULLY AND KEEP IN A SAFE PLACE FOR FUTURE REFERENCE BY A SERVICE TECHNICIAN.

INTRODUCTION

The boiler is a natural draft oil fired hot water boiler comprised of cast iron sections. The boiler is available with 4, 5, 6 or 7 cast iron sections. These sections are held together by push nipples and threaded rods.

The boiler family is capable of firing #2 fuel oil from 0.75 gph up to 1.65 gph. All packaged boilers include a Honeywell aquastat, temperature and pressure gauge, 30 psi relief valve and drain valve.

IMPORTANT SAFETY WARNING FOR FIBERGLASS & CERAMIC FIBERS

WARNING

This product contains refractory ceramic fibers (RCF). RCF has been classified as a possible human carcinogen. After this product is fired, RCF may, when exposed temperature greater than 1800°F, change into a known human carcinogen. When disturbed as a result of servicing or repair, RCF becomes airborne and, if inhaled, may be hazardous to your health.

WARNING

This product contains fiberglass wool. Fiberglass has been classified as a possible human carcinogen. When disturbed as a result of servicing or repair, fiberglass becomes airborne and, if inhaled, may be hazardous to your health. May cause irritation to skin, eyes and respiratory tract. Adhere to the following precautions and procedures.

AVOID INHALING FIBER PARTICULATES AND DUST.

PRECAUTIONARY MEASURES:

Do not remove or replace fiberglass or previously fired RCF (combustion chamber insulation, target walls, breech gasket, flue cover gasket, etc.) or attempt any service or repair work involving RCF or fiberglass without wearing the following protective gear:

1. A national Institute for Occupational Safety and Health (NIOSH) approved respirator.
 2. Long sleeved, loose fitting clothing
 3. Gloves
 4. Eye protection
- Take steps to assure adequate ventilation.
 - Wash all exposed body areas gently with soap and water after contact.
 - Wash work clothes separately from other laundry and rinse washing machine after use to avoid contaminating other clothes.
 - Discard used RCF components by sealing in air tight plastic bag.



FIRST AID PROCEDURES:

- **If Contact with eyes:** Flush with water for at least 15 minutes. Seek immediate medical attention if irritation persists.
- **If contact with skin:** Wash affected area gently with soap and water. Seek immediate medical attention if irritation persists.
- **If breathing difficulty develops:** Leave the area and move to a location with clean fresh air. Seek immediate medical attention if breathing difficulties persists.
- **If Ingestion occurs:** Do not induce vomiting. Drink plenty of water. Seek immediate medical attention.

TABLE OF CONTENTS

SECTIONS

RULES FOR SAFE INSTALLATION AND OPERATION	5
BEFORE YOU START	7
BOILER RATINGS & CAPACITIES	8
LOCATING THE BOILER	9
ASSEMBLING THE BOILER	13
BOILER SYSTEM PIPING	21
PIPING DIAGRAMS	23
FUEL OIL PIPING	35
ELECTRICAL CONNECTIONS	37
CHIMNEY AND CHIMNEY CONNECTIONS	39
OPERATING THE BOILER - SYSTEM START-UP	43
OIL BURNER, NOZZLE, & AIR SETTINGS	50
MAINTENANCE	52
OIL BOILER / BURNER CLEANING INSTRUCTIONS	54
TROUBLESHOOTING	57
NOTES	59
SERVICE RECORD	60

RULES FOR SAFE INSTALLATION AND OPERATION

The following terms are used throughout this manual to bring attention to the presence of hazards at various risk levels, or to important information concerning product life. These symbols are based on ANSI Z535.6 standard for product literature.

DANGER

Indicates an *imminently* hazardous situation which, if not avoided, *will* result in death, serious injury or substantial property damage.

WARNING

Indicates a potentially hazardous situation which, if not avoided, could result in death, serious injury or substantial property damage.

CAUTION

Indicates a potentially hazardous situation which, if not avoided, could result in minor or moderate injury or property damage.

NOTICE

Indicates special instructions on installation, operation or maintenance which are important but not related to personal injury hazards.

All boilers must be installed in accordance with National, State or Provincial and Local plumbing, heating and electrical codes and the regulations of the serving utilities. These codes and regulations may differ from this instruction manual. Authorities having jurisdiction should be consulted before installations are made. In all cases, reference should be made to the following standards:

USA BOILERS

1. Current Edition of American National Standard ANSI/NFPA 31, "Installation of Oil Burning Equipment", for recommended installation practices.
2. Current Edition of American National Standard ANSI/NFPA 211 "Chimneys, Fireplaces, Vents and Solid Fuel Burning Appliances" for venting requirements.
3. Current Edition of American Society of Mechanical Engineers ASME CSD-1, "Controls and Safety Devices for Automatically Fired Boilers" for assembly and operations of controls and safety devices.
4. All wiring on boilers installed in the USA shall be made in accordance with the National Electrical Code and/or local regulations.

CANADIAN BOILERS

1. Current Edition of Canadian Standards Association CSA B139, Installation Code for Oil Burning Equipment" for recommended installation practices.
2. All wiring on boilers installed in Canada shall be made in accordance with the Canadian Electrical Code C22.2 and/or local regulations.

WARNING

This boiler has been designed for residential installations. If used for commercial applications, all jurisdictional requirements must be met. This may require wiring and/or piping modifications. The manufacturer is not responsible for any changes to the original design.

DANGER

DO NOT store or use gasoline or other flammable vapors or liquids in the vicinity of this or any other appliance. DO NOT use gasoline crankcase drainings or any oil containing gasoline.

RULES FOR SAFE INSTALLATION AND OPERATION

WARNING

- Improper installation, adjustment, alteration, service or maintenance can cause property damage, personal injury or loss of life. Failure to follow all instructions in the proper order can cause personal injury or death. Read and understand all instructions, including all those contained in component manufacturers' manuals which are provided with the appliance before installing, starting-up, operating, maintaining or servicing this appliance. Keep this manual and literature in legible condition and posted near appliance for reference by owner and service technician.
- This boiler requires regular maintenance and service to operate safely. Follow the instructions contained in this manual.
- Installation, maintenance and service must be performed only by an experienced, skilled and knowledgeable installer or service agency.
- All heating systems should be designed by competent contractors and only persons knowledgeable in the layout and installation of hydronic heating systems should attempt installation of any boiler.
- Installation is not complete unless a pressure relief valve is installed into the 3/4" tapping located on supply manifold. (See ASSEMBLING THE BOILER - Trim & Controls and Water Boiler Piping Sections of this manual for details.)
- It is the responsibility of the installing contractor to see that all controls are correctly installed and are operating properly when the installation is complete.
- The boiler is suitable for installation on combustible flooring. Do not install boiler on carpeting.
- Do not tamper with or alter the boiler or controls.
- Inspect flue ways at least once a year- Preferably at the start of the heating season. The inside of the combustion chamber, the vent system and boiler flue ways should be cleaned if soot or scale has accumulated. When cleaning this boiler, take precaution to avoid damage to burner swing door insulation. If damaged, or if there is evidence of previous damage, burner swing door insulation must be replaced immediately.
- Oil Burner and controls must be checked at least once a year or as may be necessary.
- Do not operate unit with controls using jumpers or absent controls or safety devices.
- Do not operate unit if any control, switch, component or device has been subject to water.
- Appliance materials of construction, products of combustion and the fuel contain alumina, silica, heavy metals, carbon monoxide, nitrogen oxides, aldehydes and /or other toxic or harmful substances which can cause death or serious injury and which are known to the State of California to cause cancer, birth defects and other reproductive harm. Always use proper safety clothing, respirators and equipment when servicing or working nearby the appliance.
- This product contains fiberglass wool and ceramic fibers. Possible cancer hazard. May cause irritation to skin, eyes and respiratory tract. To avoid this hazard, wear a dust mask and gloves when handling fiberglass and ceramic fibers.

NOTICE

Surface rust on cast iron sections may be attributed to the manufacturing process as well as condensation during storage. Surface rust is normal and does not affect the performance or longevity of a boiler.

SAFE INSTALLATION AND OPERATION

1. Read the Owner's Manual for Safe Operation carefully. Failure to follow the rules for safe operation and the instructions can cause a malfunction of the boiler and result in death, serious bodily injury, and/or property damage.
2. Before servicing, allow boiler to cool. Always shut off any electricity and oil supply to the boiler when working on it.
3. Inspect oil line and connections for leaks.
4. Verify oil burner nozzle is the proper size. Over-firing will result in early failure of the boiler sections, and result in a potentially dangerous situation.
5. Never vent this boiler into an enclosed space. Always vent to the outside. Never vent to another room or inside a building.
6. Be sure there is adequate air supply for complete combustion.
7. Follow a regular service and maintenance schedule for efficient, safe and reliable operation.
8. Be aware when piping the relief valve that if the system pressure exceeds the safe limit of 30 pounds per square inch, the relief valve will automatically lift open. Lifting of the relief valve can discharge large quantities of steam and hot water, which may damage the surroundings. Before installing the relief valve read the manufacturer's instructions and maintenance section of the manual on relief valves. The safety relief valve must be piped to a safe location. Check with authorities having jurisdiction.
9. Installation and sizing of the expansion tank must consider the heating systems total water volume, temperature, boiler initial fill pressure, and system arrangement. An improperly installed and sized expansion tank may result in frequent lifting of the relief valve or other heating system problems. For proper installation, sizing, and maintenance of the expansion tank follow the guidelines established by the boiler manufacturer and the expansion tank manufacturer.
10. Expansion tank performance and life expectancy can be hindered by overfilling the boiler. The boiler manufacturer recommends an initial fill pressure of 10-12 PSIG. For higher fill pressures the expansion tank's air charge will need to be increased to match the fill pressure. Consult the expansion tank manufacturer's guidelines for sizing and selection.
11. Purging the heating system of air and gases when first putting the boiler into service is critical for proper circulation and quiet performance. Once the air is purged, for boiler installations using float type vents, the air vents should be closed for normal operation. If air is heard or noticed by a loss of heat, purge the system and open the vents for a short period of time.

BEFORE YOU START

Inspect the shipment carefully for any signs of damage. All equipment is carefully manufactured, inspected and packaged. Our responsibility ceases upon delivery of crated boiler to the carrier in good condition. Any claims for damage or shortage in shipment must be filed immediately against the carrier by the consignee. No claims for variances form, or shortage in orders, will be allowed by the manufacturer unless presented within sixty (60) days after receipt of goods.

Complete all of the following prior to installing the boiler:

- A. Check to be sure you have selected the right size boiler with the proper capacity. The I=B=R rating of the boiler selected should be greater than or equal to the calculated peak heating load (heat loss) for the building or area(s) served by the boiler and associated hot water heating systems. See boiler rating and capacity table previously listed in this manual. Any heat loss calculations used should be based on approved methods.
- B. Boiler must be supplied with the proper oil supply and oil piping, sufficient fresh combustion air, and a suitable electrical supply.
- C. Boiler must be connected to a suitable venting system and a piping system adequate to distribute the heating load.
- D. A thermostat must be properly located and installed for control of the heating system.

NOTICE

If you cannot confidently address the requirements in this manual, check with local authorities and obtain professional help where needed. The **OPERATING INSTRUCTIONS** and **MAINTENANCE** sections in this manual are vital to the proper and safe operation of the heating system. Take the time to be sure they are all done.

BOILER RATINGS & CAPACITIES

This low pressure oil fired hot water boiler is constructed and hydrostatically tested for a maximum working pressure of 65 PSIG (pounds per square inch gauge) in accordance with the latest revision of the A.S.M.E. (American Society of Mechanical Engineers) Boiler and Pressure Vessel Code Section IV Standards for heating boilers.

The **Heating Capacity** indicates the amount of heat available after subtracting the losses up the stack. Most of this remaining heat is available to heat water. A small portion is heat from the jacket and surfaces of the boiler and it is assumed that this heat stays in the structure. The Net I=B=R Rating represents the portion of the remaining heat that can be applied to heat the radiation or terminal units (i.e. finned tube baseboard, cast iron radiators, radiant floor, etc.). The difference between the Heating Capacity and the Net I=B=R Rating, called the piping and pickup allowance, establishes a reserve for heating the volume of water in the system and offsetting heat losses from the system piping. The Net I=B=R Ratings shown are based on a piping and pickup factor of 15% in accordance with the I=B=R Standard as published by the Hydronics Institute. The **Net I=B=R Rating** of the boiler selected should be greater than or equal to the calculated peak heating load (heat loss) for the building or area(s) served by the boiler and associated hot water heating systems. The manufacturer should be consulted before selecting a boiler for installations having unusual piping and pickup requirements.

TABLE 1: OIL-FIRED HOT WATER BOILERS - RATINGS & CAPACITIES												
Number of Sections	Firing Rate GPH	Input MBTU	Heating Capacity MBH	Net I=B=R Rating MBH	MAWP Water (PSIG)	Pump PSIG	AFUE	Min. relief Valve Cap	Max. Water Temp	Chimney Size (Round)	Chimney Size (Square)	Flue Size
4	0.75	105	90	79	65*	140	86.0	90	250°F	6"	6 3/4"	5"
5	1.00	140	120	105	65*	140	86.5	120	250°F	6"	6 3/4"	5"
6	1.30	182	157	136	65*	140	86.5	157	250°F	7"	8"	5"
7	1.65	231	198	172	65*	175	85.8	198	250°F	7"	8"	6"

* Standard boiler is supplied with a 30psig relief valve.

Standard boiler Aquastat is 220°F maximum.

For boiler dimensions, see **Table 2A** and **Figure #1**.

For burner settings & nozzle sizes, see **Oil Burner, Nozzle & Air Settings** section.

LOCATING THE BOILER

1. Locate the boiler in front of the final position before removing the crate.
2. Locate the unit so the vent pipe connection to chimney will be short and direct.
3. The Boiler is suitable for installation on combustible floor. Boiler cannot be installed on carpeting.
4. For basement installation, provide a solid elevated base, such as concrete, if floor is not level, or if water may be encountered on floor around boiler.
5. Provide recommended service clearance, if applicable, as follows:
 - **Clearance from Jacket Front Panel**
 - 24" for servicing burner
 - **Clearance from Jacket Side Panels**
 - 24" for burner swing door, if opened fully with burner mounted, otherwise 2" with burner removed.
 - **Clearance From Jacket Rear Panel**
 - 12" minimum for rear smoke box cleaning. (Note: this dimension will also be controlled by horizontal to vertical to horizontal smoke pipe arrangement. See **Figure #1**.)
6. For minimum clearances to combustible materials, see **Figure #1** and **Table 2B**.
7. Fresh air for combustion and ventilation must be available at the boiler. Ventilating and combustion air must enter boiler room without restrictions.
8. Be sure installation is in accordance with the requirements of the local authorities having jurisdiction. Compliance with these regulations is required. In the absence of local codes, in the United States, follow NFPA 31 Installation of Oil Burning Equipment, latest revision. In Canada, use CSA B 139, latest revision.
9. Clearance to venting is for single wall flue pipe. If Type L vent is used, clearance may be reduced to the minimum required by the vent pipe manufacturer.

TABLE 2A: BOILER DIMENSIONS

Section	Height	Depth	Width
4	34 1/4"	17 3/4"	17 3/4"
5	34 1/4"	20 7/8"	17 3/4"
6	34 1/4"	24 1/8"	17 3/4"
7	34 1/4"	27 1/2"	17 3/4"

TABLE 2B: BOILER CLEARANCES

Unit	Combustible Clearance	Accessibility, Cleaning, and Servicing
Top	12"	24"
Right Side	2"	24"
Left Side	2"	24"
Floor	Combustible	No Requirement
Front	17"	24"
Back	See Flue	18"

All distances measured from the boiler jacket or flue.

Figure #1

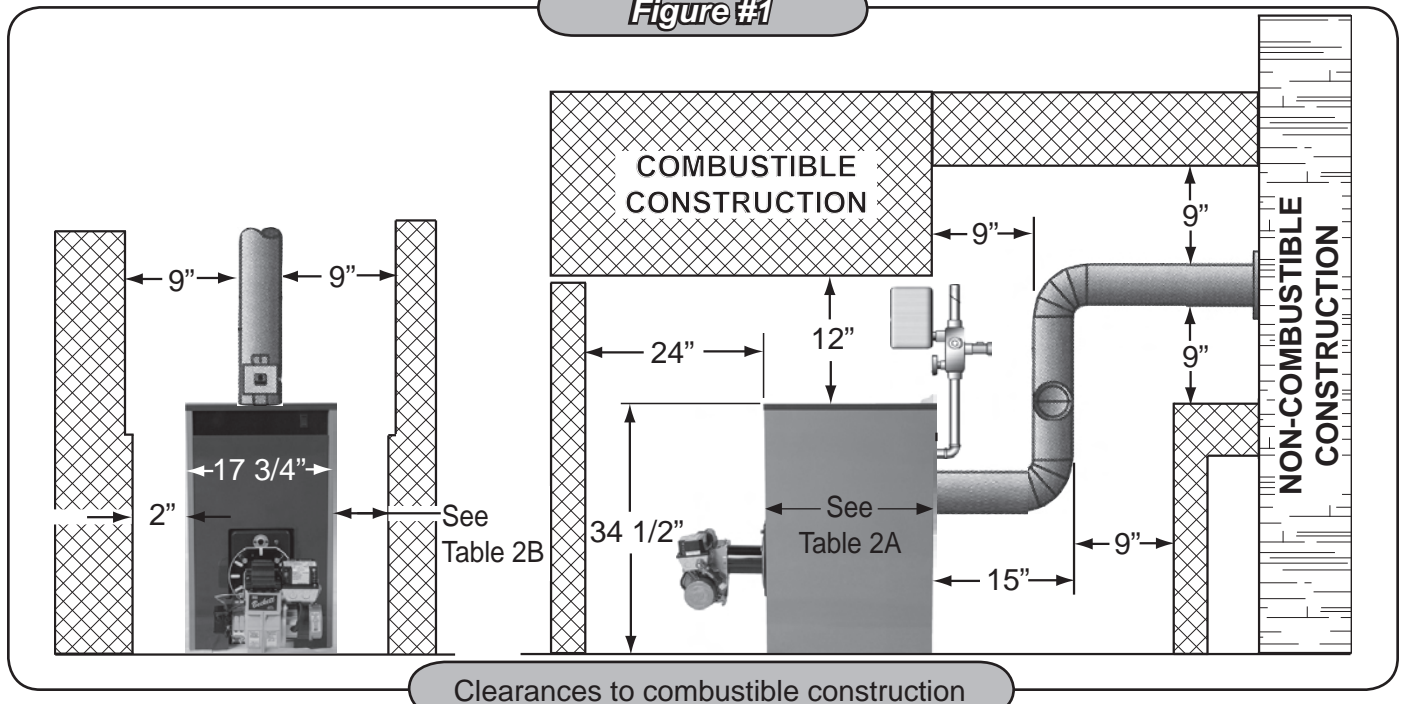

INSTALLATION REQUIREMENTS

NOTE: ALWAYS KEEP THE MANUAL FUEL SUPPLY VALVE SHUT OFF IF THE BURNER IS SHUT DOWN FOR AN EXTENDED PERIOD OF TIME.

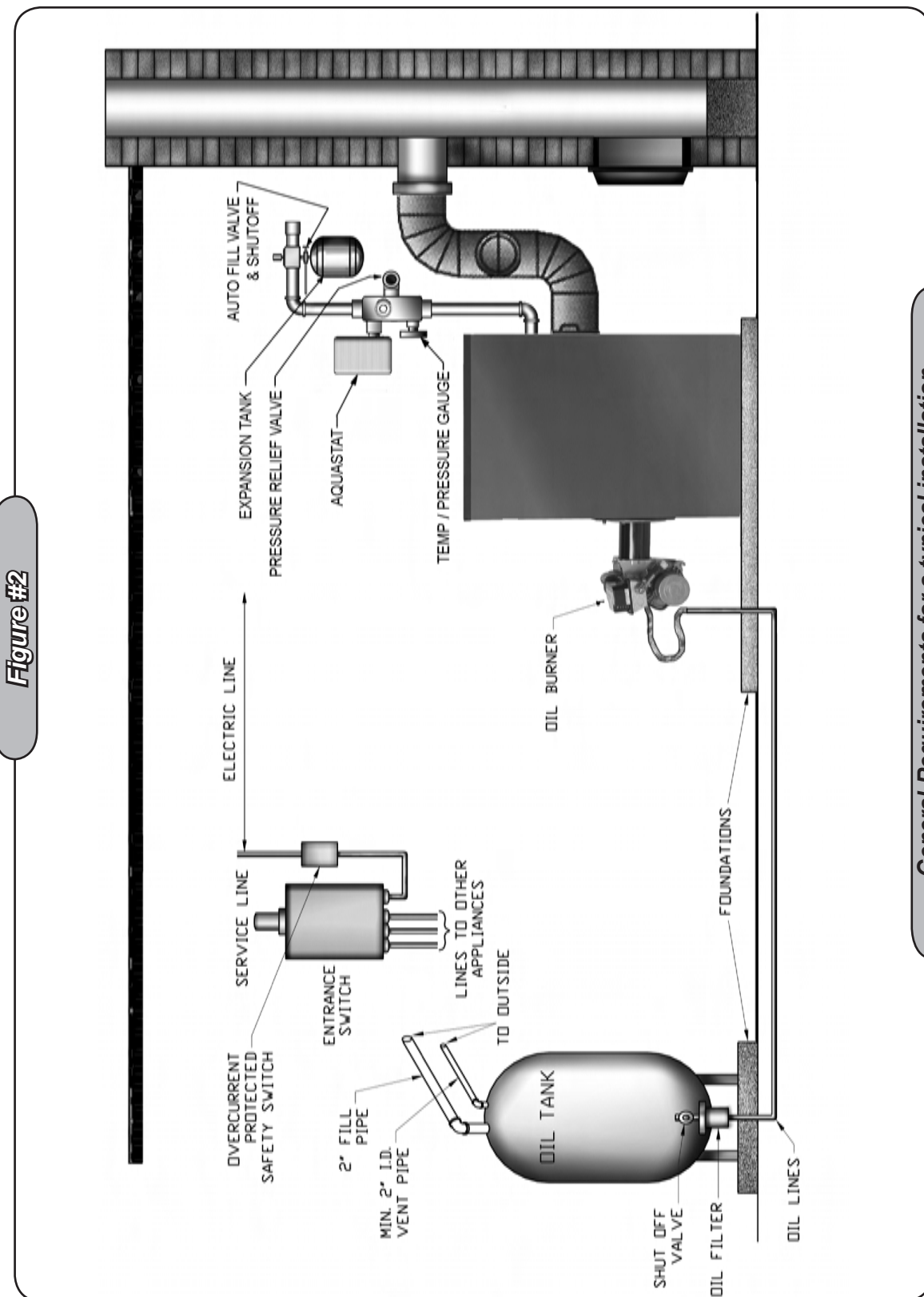

FRESH AIR FOR COMBUSTION

! WARNING

Adequate combustion and ventilation air must be provided to assure proper combustion and to maintain safe ambient air temperatures. Do not install boiler where gasoline or other flammable vapors or liquids, or sources of hydrocarbons, (i.e. Bleaches & fabric softeners) are used or stored.

NOTE: If you use a fireplace or a kitchen or a bathroom exhaust fan, you should install an outside air intake. These devices will rob the boiler and water heater of combustion air.

1. Determine volume of space (boiler room). Rooms communicating directly with the space in which the appliances are installed, through openings not furnished with the doors, are considered a part of the space. $\text{Volume (ft}^3\text{)} = \text{Length (ft)} \times \text{Width (ft)} \times \text{Height (ft)}$
 2. Determine total input of all appliances in the space. Add inputs of all appliances in the space and round the result to the nearest 1000 BTU/hr.
 3. Determine type of space. Divide Volume by total input of all appliances in space. If the result is greater than or equal to 50 ft³/1000 BTU/hr, then it is considered an **unconfined space**. If the result is less than 50 ft³/1000 BTU/hr, then the space is considered a **confined space**.
 4. When a boiler is located in an unconfined space of a conventionally constructed building, the fresh air infiltration through cracks around windows and doors normally provides adequate air for combustion and ventilation.
 5. Provide outdoor air for boiler located in a confined space or an unconfined space in a building of unusually tight construction. Outdoor air may be provided with the use of two permanent openings which communicate directly or by duct with the outdoors or spaces (crawl or attic) freely communicating with the outdoors. Locate one opening within 12 inches of top of space. Locate remaining opening within 12 inches of bottom of space. Size each opening per the following:
 - a. **Direct communication with outdoors:** Minimum free area of 1 square inch per 4,000 BTU per hour input of all equipment in space.
 - b. **Vertical Ducts:** Minimum free area of 1 square inch per 4,000 BTU per hour input of all equipment in space. Duct cross-sectional area shall be same as opening free area.
 - c. **Horizontal Ducts:** Minimum free area of 1 square inch per 2,000 BTU per hour input of all equipment in space. Duct cross-sectional area shall be same as opening free area.
Alternate method for boiler located within confined space: Use indoor air if two permanent openings communicate directly with additional space(s) of sufficient volume such that the combined volume of all spaces meet criteria for unconfined space. Size each opening for minimum free area of 1 square inch per 1,000 BTU per hour input of all equipment in spaces, but not less than 100 square inches.
6. Louvers and Grilles of Ventilation Ducts
 - a. All outside openings should be screened and louvered. Screens used should not be smaller than 1/4 inch mesh. Louvers will prevent the entrance of rain and snow.
 - b. Free area requirements need to consider the blocking effect of louvers, grilles or screens protecting the openings. If the free area of the louver or grille is not known, assume wood louvers have 20-25% free area and metal louvers and grilles have 60-75% free area.
 - c. Louvers and grilles must be fixed in the open position, or interlocked with the equipment to open automatically during equipment operation.

Figure #2A

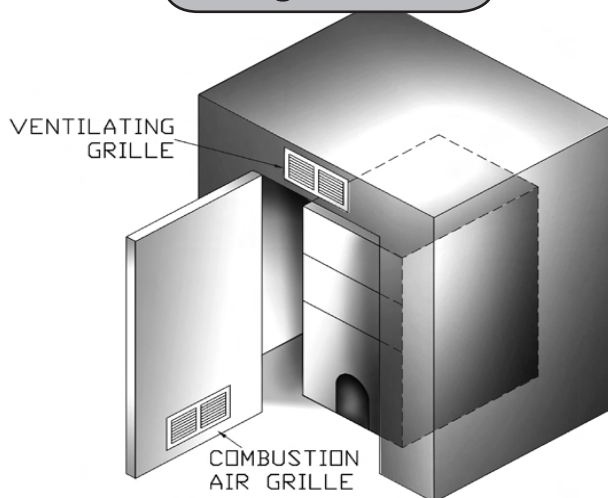

AIR OPENINGS FOR BOILER LOCATED IN CONFINED SPACE (Utility Room)

FRESH AIR FOR COMBUSTION

FRESH AIR DUCT CAPACITIES FOR DUCTS SUPPLYING FRESH AIR TO BOILER IN TIGHTLY CONSTRUCTED HOUSES

TABLE 3: FRESH AIR DUCT CAPACITIES THROUGH LOUVERS			
Fresh Air Duct Size	1/4" Mesh Screen	Wood Louvers	Metal Louvers
	(Btuh)*	(Btuh)*	(Btuh)*
3 1/2" x 12"	144,000	36,000	108,000
8" x 8"	256,000	64,000	192,000
8" x 12"	384,000	96,000	288,000
8" x 16"	512,000	128,000	384,000

**Btuh = British Thermal Units per hour based on opening covered by 1/4" mesh screen, wood louvers, or metal louvers.*

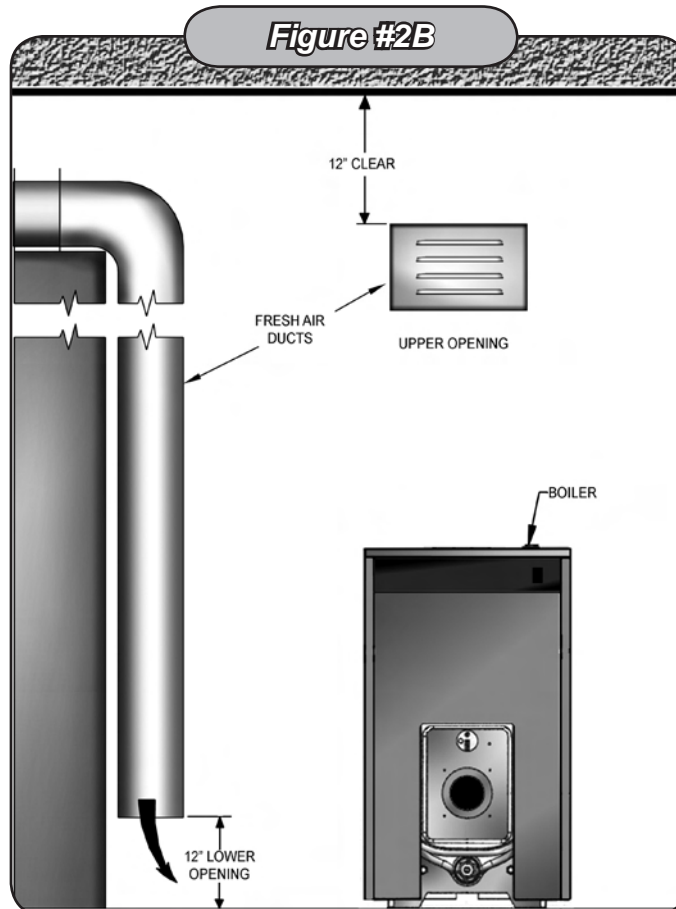

ASSEMBLING THE BOILER

1. Remove Crate

- A. Remove all fasteners at crate skid.
- B. Lift outside container and remove all other inside protective spacers and bracing. Remove burner and miscellaneous parts boxes.

2. Remove Boiler from skid.

Boiler is secured to base with 4 screws. Remove all securing hardware.

3. Move boiler into permanent position by sliding or walking into place.



CAUTION

DO NOT DROP BOILER. DO NOT BUMP BOILER JACKET AGAINST FLOOR.

4. Open the burner swing door.

Throughout this manual, you will be instructed to open and close the burner swing door for various reasons. There is a proper and improper method to closing and securing the burner swing door opened for inspection, cleaning or field service.

- A. Loosen and remove non-hinged side latching hardware.
- B. Remove hinged side latching hardware.
- C. Door can be swung to the fully open position, approximately 90 to 120 degrees, with the burner mounted providing that there is 22" of clearance to the adjacent wall.



CAUTION

If burner door is lifted when opened, it can come off it's hinges.

NOTICE

If reduced clearance prevents the door from opening fully, one of the following can provide full access:

Burner can be removed to allow full rotation of door. Door with burner mounted can be lifted off hinges and set aside during servicing.

The door mounting hardware is reversible from left side hinge (as shipped) to right side hinge. To reverse the hinge arrangement: (See *Figure #2C*)

- Lift door off mounting eye bolts and set aside.
- Remove mounting eye bolts from left side.
- Move door mounting eye bolts to right side.
- Tighten both sets of hardware.
- Lift door and place integral cast hinge pins on door into slotted mounting bracket holes.

NOTICE

It is recommended that hinges should be on same side as flexible oil line in order to swing the door open.

5. Inspect Swing door insulation and rope gasket.

- A. Inspect fiber rope located on the swing door. The rope must be evenly distributed around the perimeter of the door groove and cannot bunch or overhang. There must not be a gap where the two ends of the rope meet. Repair or replace if the rope is damaged or if there is a gap between the ends.
- B. Inspect burner swing door insulation for damage.
- C. By design, the combustion chamber and raised portion between the 2nd and 3rd pass flue ways should make an impression in door insulation.
- D. Do not close and secure door at this time.

Figure #2C

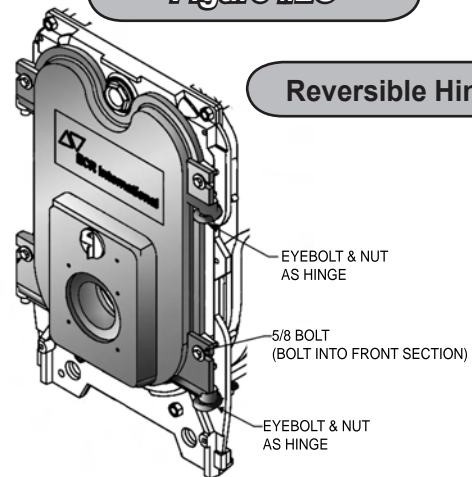

NOTICE

For the purpose of these instructions, all pipe connections shall use pipe dope or Teflon tape to assure water tight connections unless otherwise instructed. For steps **6** thru **16**, refer to *Figure #3*.

6. **Open accessory carton** and remove contents. Identify the components using the illustrations throughout this section as applicable to your installation.
7. **Remove top panel.** Remove sheet metal screws securing the top panel to jacket rear panel. Slightly lift rear of jacket top panel away from side panels. Dunkirk only: Push the top panel toward the rear of the boiler and lift off of side panels to gain access to internal control panel.
8. **Locate the shorter of the two 1 1/4" nipples.** Thread thru the insulation slot into supply port in rear of boiler. Locate the 1 1/4" x 90° elbow and assemble onto nipple. Be sure connections are **tight** and outlet is facing directly up. See *Figure #3*.
9. **Locate the longer of the two 1 1/4" nipples.** Assemble onto elbow. See *Figure #3*.

Figure #3

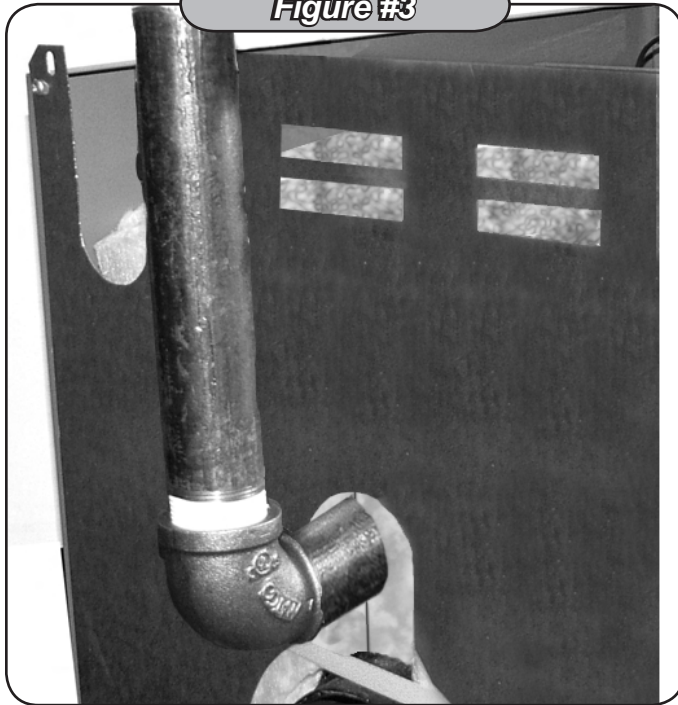

⚠ WARNING

NO VALVE MAY BE INSTALLED BETWEEN BOILER AND CONTROLS MANIFOLD OR SAFETY RELIEF VALVE.

10. Locate the cast iron supply manifold shown in *Figure #3*. Flow arrow must point up. Thread onto the long nipple. Using hex head on top, tighten manifold until NPT bosses for Aquastat well and Temp / Pressure gauge are facing toward front of boiler and joint is water tight.
11. **Install Low Water Cut Off.** (Optional pre-wired kit- If not used, install 3/4" NPT plug provided in parts bag.) See *Figure #6*.
12. **Install High Temp Limit Manual Reset.** (Optional pre-wired kit - If not used, install 1/2" NPT plug provided in parts bag). See *Figure #6*.
13. **Install Temperature / Pressure Gauge.** Install into lower front NPT port. See *Figure #6*.
14. **Install Aquastat Control immersion well.** Install in upper NPT port facing front. See *Figure #6*.
15. **Install Aquastat Control & Harness Assembly.** Loosen mounting screw on bottom of case. Insert sensor into immersion well. Mount control on immersion well and tighten screw to secure control as shown in *Figure #4*. (Shown without LWCO.)

Figure #4

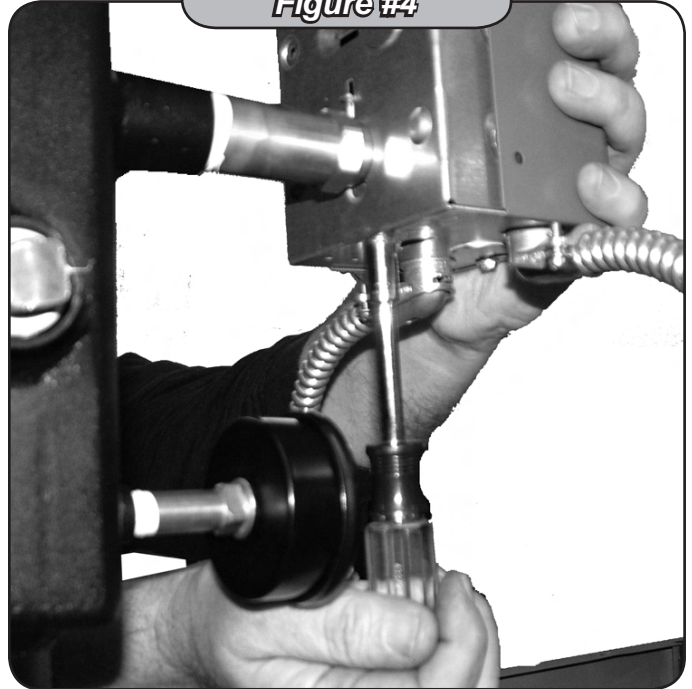

16. Install Relief Valve (Refer to *Figure #5*)

- A. Locate 3/4" NPT x 90° elbow. Install elbow using 3/4" NPT boss on rear of control manifold. Elbow must be installed with outlet facing directly up. Install relief valve with outlet facing either horizontally right or left of boiler.
- B. Pipe discharge of relief valve. Installation of the relief valve must be consistent with ANSI/ASME Boiler and Pressure Vessel Code, Section IV.

⚠ WARNING

Relief valve discharge piping must be piped near floor to eliminate potential of severe burns. DO NOT pipe in any area where freezing can occur. DO NOT install any shut of valves, plugs or caps.

Figure #5

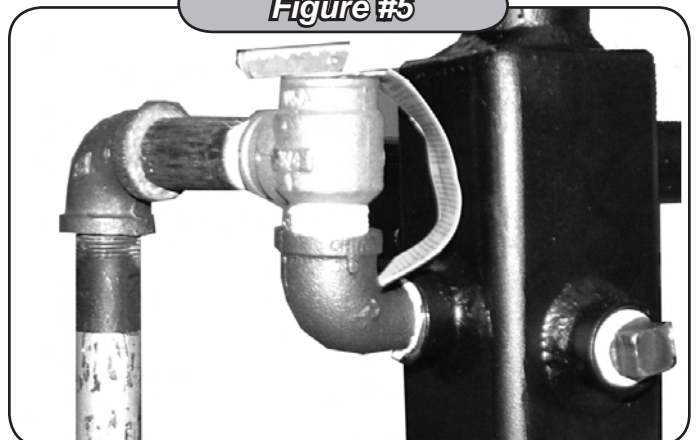

ASSEMBLING THE BOILER

Figure #6 (with optional accessories shown)

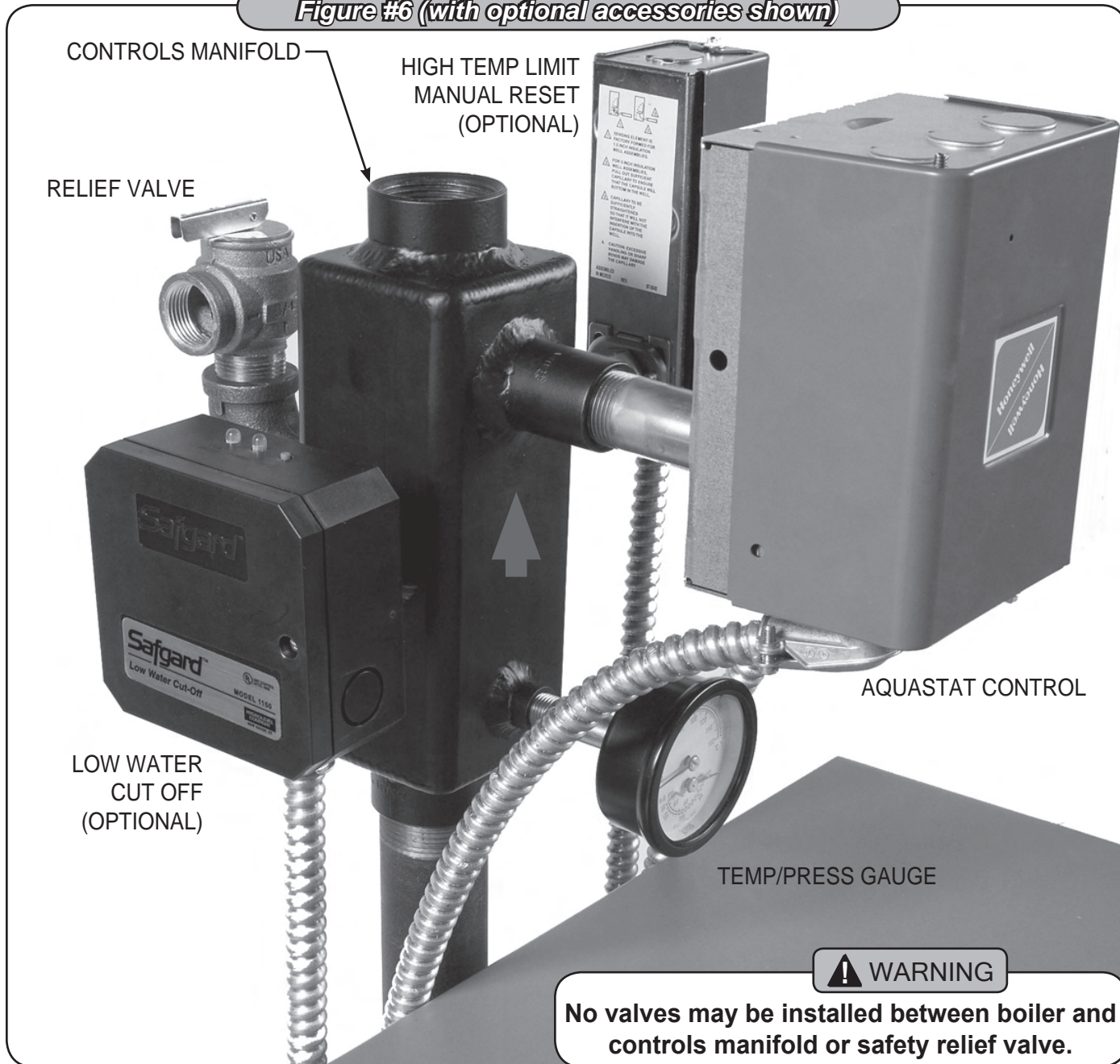

TABLE 4: CONTROLS MANIFOLD PORT SCHEDULE

PORT	PORT SIZE	DESCRIPTION
A	1/4" NPT	TEMPERATURE PRESSURE GAUGE
B	3/4" NPT	LOW WATER CUT OFF (OPTIONAL)
C	1/2" NPT	HIGH TEMPERATURE LIMIT MANUAL RESET (OPTIONAL)
D	3/4" NPT	RELIEF VALVE
E	3/4" NPT	AQUASTAT CONTROL

17. **Check Installation of Liners.** (Not all models)
- A. Check oval or V-shaped liner. See *Figure #7 & #8*. If installing the oval liner, use a rubber mallet to tap it into place. It should be flush with the front edge of the heat exchanger fins.
 - B. To install flue way baffles in 3rd pass, slide baffle in flue way until position tab touches the casting between the 2nd and 3rd Pass flue way. See *Figure #9*.

⚠ CAUTION

These baffles will generate higher efficiencies and lower stack temperatures. Under certain conditions, a lower gross stack temperature entering the chimney has the potential to be cooled below the dew point and create condensate on interior surfaces. Flue gas condensate is corrosive, which requires special consideration and must be addressed immediately. DO NOT install baffles until you have read the section regarding Venting completely.

18. **Connect the Field Wiring.** See Section **Electrical Connections** as well as *Figure #10 & #11*.

- A. Route the wire harnesses from the LWCO (optional), the High Level Manual Reset (optional) and the harness from the Aquastat through the rear jacket panel. (See *Figure #11*) Connect the molex plugs on the end of each wire harness to its respective plug on the control panel.
- B. If the optional Low Water Cut Off and/or optional High Temperature Limit Manual Reset are not used, ensure supplied jumpers are installed. See *Figure #11*.
- C. Connect the wiring harness from the Aquastat to the circulator. See *Figure #10*.
- D. 120 volt power supply field wiring will enter through jacket rear panel.
- E. Wire the power supply as shown in *Figure #11*. Connect the green wire to the grounding lug. When installing the wiring through the hole in the control panel, be sure to use an anti abrasion cable clamp. Connect black "hot" wire to L1 of terminal block, white "N" wire to L2 of terminal block.

19. **Install the Top Panel.** Place on top of side panels and position the top panel overhanging to the front of the control panel. Push top panel toward the back of the boiler. Insert the round tabs into the holes in the top of the side panels. Install rear panel screws.

BAFFLES & LINERS			
SECTIONS	LINER	LINER LENGTH	BAFFLES IN AC CART
4	O TYPE	4"	9"
5	N/R	N/R	12"
6	V TYPE	12"	15"
7	V TYPE	14"	NONE

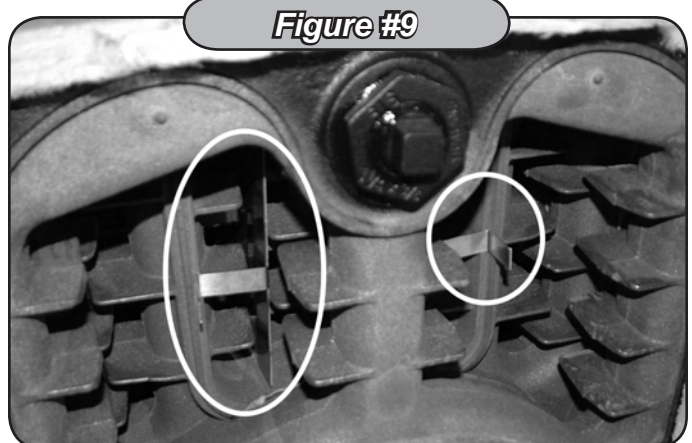
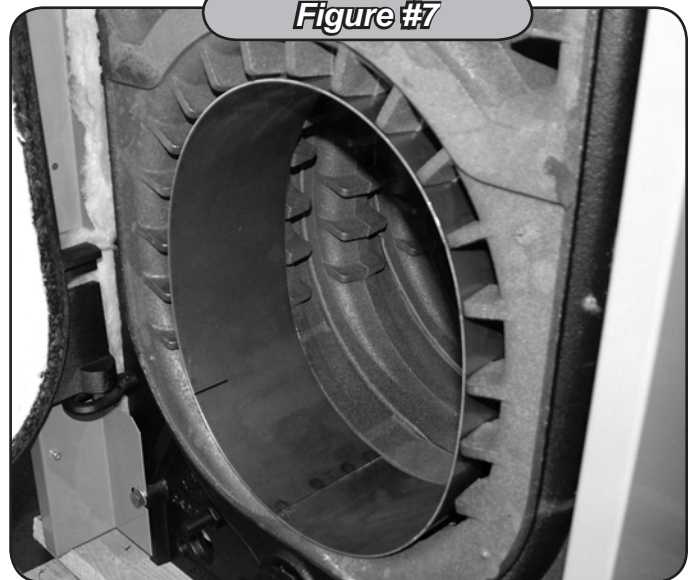

ASSEMBLING THE BOILER

Figure #10

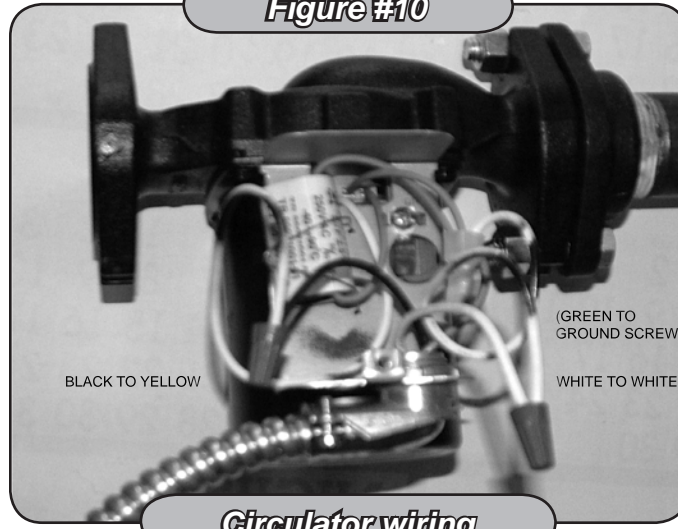

Circulator wiring

Figure #11

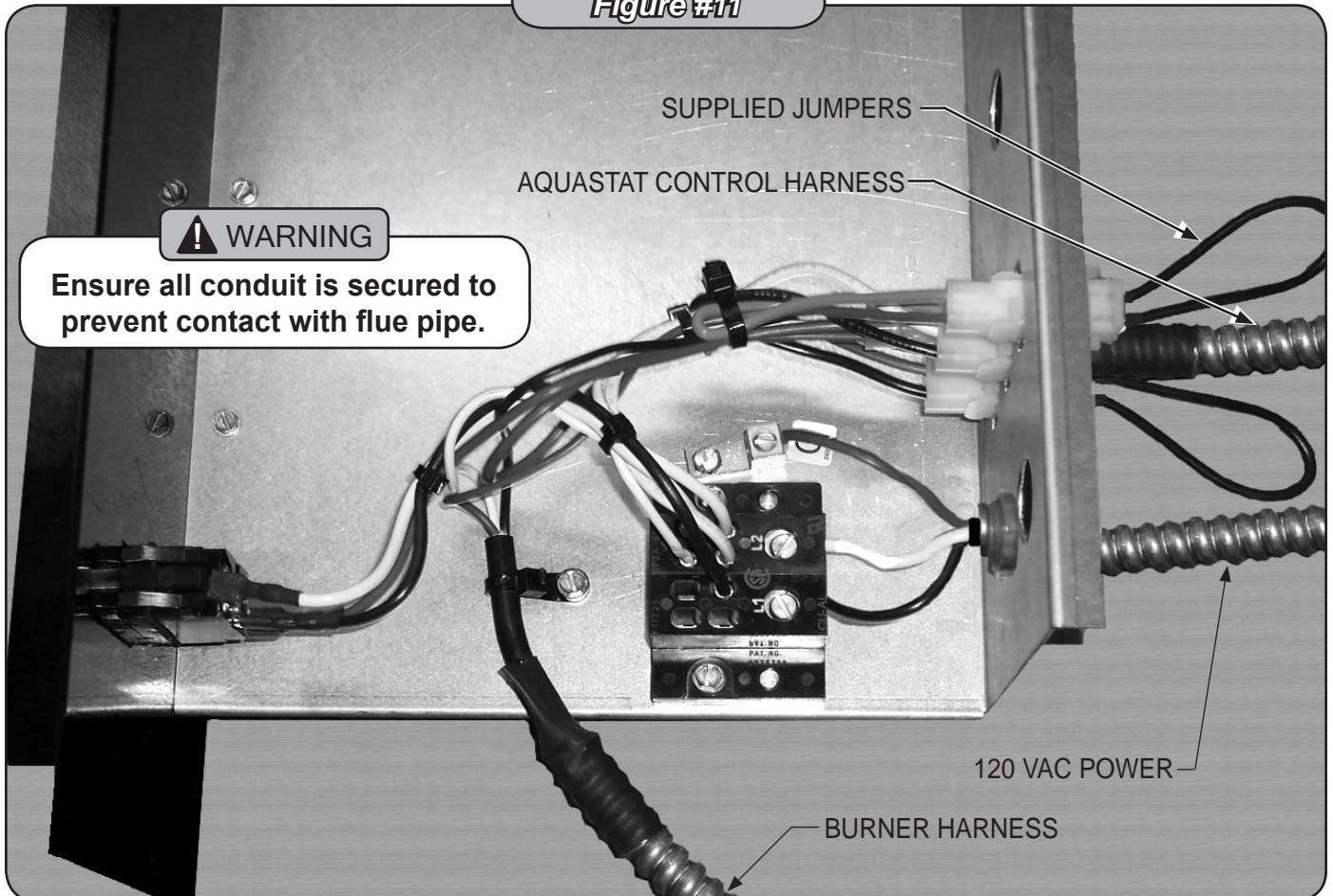

ASSEMBLING THE BOILER

20. Install the Drain Valve. Install drain valve with hose connection facing right or left. This allows clearance for the swing door to open and close with the drain and hose attached. Be sure the connection is water tight. See *Figure #12*.

Figure #12

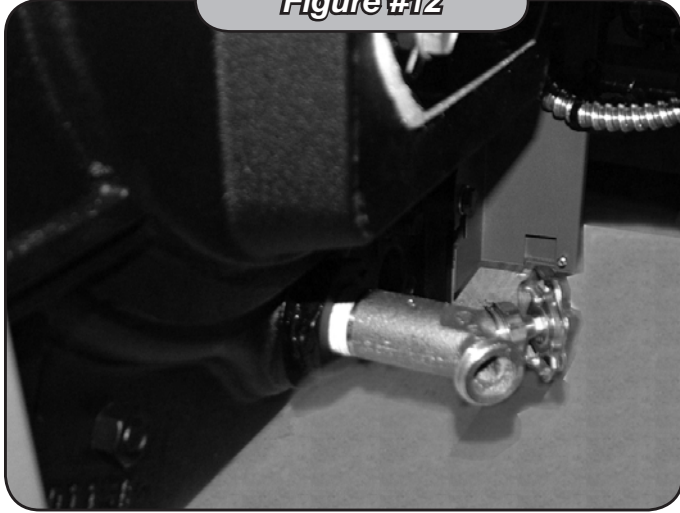

21. Close the burner swing door.

- A. Use one hand to help hold door in position by applying pressure directly to the door while re-installing the securing hardware with your opposite hand. Always install non-hinged side latching hardware first, then install hinged side hardware second. Apply additional pressure while hand tightening the hardware as far as possible, then release the pressure.
- B. Use a hand wrench to tighten door hardware and always start with the non-hinged side first. Use an alternating tightening method from non-hinged side to hinged side to tighten door equally until sealed without applying excessive torque. Never tighten hinged side flange bolt first or tighten either piece of hardware 100% without using the alternating tightening method described above.

NOTICE

When securing burner swing door, make sure door is drawn-in equally on both sides.

- C. Failure to follow the prescribed procedure could cause thread damage to casting or a leak in the door seal. If hinged side is tightened before the unhinged side, the hinged side of door cannot be drawn to provide an air-tight seal. Applying excessive torque will only cause thread damage.

22. Install oil burner.

- A. Open Burner carton and remove contents.
- B. Check oil nozzle in burner for size, angle and type, inspect electrode settings, check head setting, check air band and air shutter settings. (See **Oil Burner Settings** section of this manual.)

⚠ CAUTION

DO NOT INSTALL BURNER WITHOUT GASKET

- C. Place oil burner gasket on face of burner swing door with the 4 burner flange bolts installed part way.
- D. Align round part of key hole slots of burner flange with burner door bolts. Turn burner to lock in place.
- E. Tighten all 4 cap screws using a diagonal sequence.
- F. Plug burner power cord into power harness.
- G. Attach flexible oil hose included in parts box.

CONVENTIONAL EXPANSION TANK *(not provided)*

In a properly assembled system, the expanding water flows into an expansion tank. The expansion tank should be sized correctly because an improperly installed or sized expansion tank may result in frequent lifting of the relief valve or other heating system problems. It is important to install the tank higher than the top of the boiler. The connecting pipe from the boiler to the expansion tank shall rise continuously up to the expansion tank so that air can rise into the expansion tank.

An expansion tank is partially filled with air. The air compresses as water expands, thus forming an air pressure cushion. This “spring-like” cushion serves to maintain correct operating water pressure regardless of water temperature. This assures a “full measure” of water, even in the highest radiation unit of the system. The tank also serves as a trap for excess air in the system. The air can cause noises in the pipes and inefficient circulation in the radiators if left in the piping system.

It is possible for a tank to become “waterlogged” (filled with water). It can also become overfilled with air when filling the system with new water. Fittings on the tank and in the line to the tank are for bleeding off excess air and water.

DIAPHRAGM EXPANSION TANK *(not provided)*

The diaphragm type expansion tank takes the place of the conventional expansion tank. Carefully read the instructions packed with your tank assembly. The expansion tank should be sized and installed correctly. An improperly installed or sized expansion tank may result in frequent lifting of the relief valve or other heating system problems.

The tank typically comes with a 10-12 psig air charge. This is the same as the pressure produced in the system by an automatic fill valve set to fill the boiler to 10-12 psig with fresh water. When the system is first filled, the tank will fill partially with water. As the water is heated, and system pressure increases, the water expands into the tank and compresses the air in the tank. This compressed air cushion permits the water in the system to expand as the temperature changes and assures a “full measure” of water, even in the highest radiation unit of the system. The diaphragm type expansion tank can be mounted on the air purger fitting or at any other convenient place in the

supply or return line. It is recommended to locate the diaphragm type expansion tank in the supply line with the circulator located after the expansion tank. This configuration allows the circulator to “pump away” from the expansion tank for improved air elimination and system performance. The air eliminator fitting or air purger is not provided. The air eliminator fitting or air purger is used to help remove air from the system before it reaches the radiators. It should be installed in the supply line. Air left in the system can cause noises in the pipes and inefficient circulation in the radiators.

MAIN AIR VENT: *(not provided)*

Before a system is filled with water, there is air in the pipes and radiation units. Some of the air will be trapped as the system is filled. It is possible to eliminate most of this air through the air vents on the radiation units. A main air vent will speed and simplify this process. The main air vent should be installed on the highest point in the supply main.

AUTOMATIC FILL VALVE *(not provided)*

For safe, efficient operation, a hot water system must be filled with water. Adding new water, when needed can be done manually (by use of a hand valve in the water supply line). This requires regular attention to the system’s needs. An automatic fill valve or pressure reducing valve accomplishes this without attention. It is installed in the supply line on hot water boilers only. The valve operates through water pressure differentials. It does not require an electrical connection.

AQUASTAT RELAY CONTROL *(provided)*

The water temperature limit control in the aquastat relay is adjustable. See Aquastat instructions for how to set the limit temperature.

DRAIN VALVE *(provided)*

The drain valve is a manually operated valve that provides a means of draining all the water from the boiler and heating system. It is installed in the casting below the burner door.

CIRCULATOR

Every forced hot water system requires a circulator. A separate circulator or zone valve is required for each zone, if there are two or more zones. The circulator must have the capacity to provide the circulation required by the heating system. The circulator should be connected to the supply main and must be wired into the boiler's electrical system. See the **"System Piping"** section for piping configurations with the circulator located on the supply main piping using zone circulators or zone valves. When the piping is arranged with zone circulators and no bypass piping, the circulator provided with the boiler may be used as a zone circulator. Both piping arrangements allow the circulator to pump away from the expansion tank and show how the piping should be arranged to allow the heating system to be easily purged of air. The circulator can be installed on the return side of the boiler, if preferred.

Figure #13A
Grundfos UP 15-42 F Pump Curve

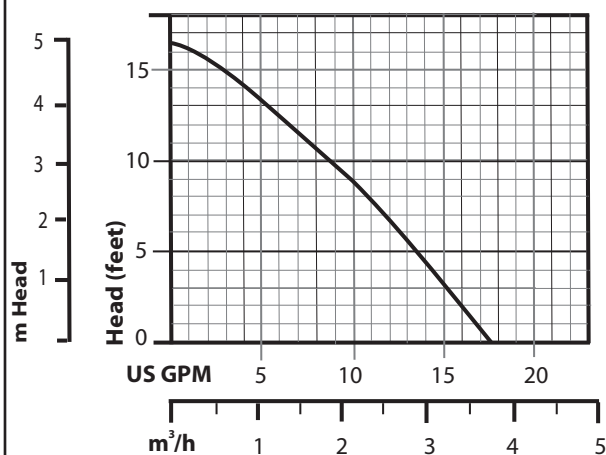

Model	Watts	Volts	Amps	Capacitor
UP 15-42F	85	115	0.74	10µF/180V*

*Supplied with pump

Figure #13B
Taco 007-F5 Pump Curve

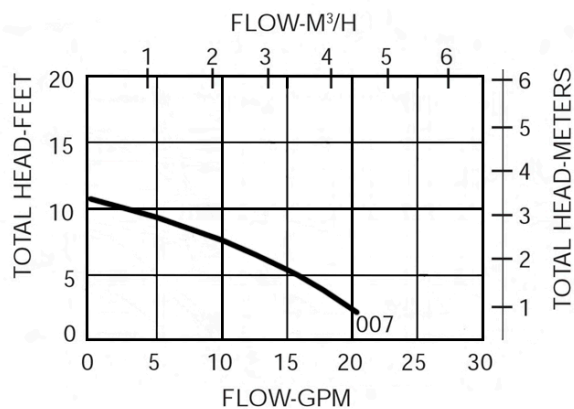

Model	Volts	Amps	Capacitor
007-F5	115	0.70	Supplied w/ pump

BOILER SYSTEM PIPING

NOTICE

Failure to pipe boiler correctly may result in excessive noise and other related problems.

Existing water system evaluation

A good system will prevent oxygen contamination of boiler water.

1. Causes of oxygen contamination may be:
 - a. Addition of excessive make up water as a result of leaks.
 - b. Absorption through open tanks and fittings.
 - c. Oxygen permeable materials in the distribution system.
2. To ensure long product life, oxygen sources must be eliminated. Take the following measures:
 - a. Repairing system leaks.
 - b. Eliminate open tanks from the system.
 - c. Eliminate and/or repair fittings which allow oxygen absorption.
 - d. Use non-permeable materials in the heating system.

WARNING

System supply and return piping must be connected to correct boiler fittings. ECR International recommends sizing the system circulator to supply sufficient flow (GPM) to allow a 20°F temperature differential in the system. When sizing the system circulator, the single most restrictive zone should be used to determine maximum pressure drop.

Connect system supply and return piping to boiler

See PIPING DIAGRAMS. Also, consult I=B=R Installation and Piping Guides.

1. If this boiler is used in connection with refrigeration systems, the boiler must be installed so that the chilled medium is piped in parallel with the heating boiler using appropriate valves to prevent the chilled medium from entering the boiler. See **piping diagram 12**. Also, consult I=B=R installation and Piping Guides.
2. If this boiler is connected to heating coils located in air handling units where they may be exposed to refrigerated air, the boiler piping must be equipped with flow control valves to prevent gravity circulation of boiler water during the operation of the cooling system.

3. If a low water cut-off is required, it must be mounted in the 3/4" supply manifold tapping or in the system piping above the boiler. The minimum safe water level of a hot water boiler is just above the highest water containing cavity of the boiler; that is, a hot water boiler must be full of water to operate safely.

WARNING

The use of a low water cut off device is recommended.

4. When the installation of the boiler is for a new heating system, first install all of the radiation units (panels, radiators, baseboard, or tubing) and the supply and return mains. After all heating system piping and components have been installed, make final connection of the system piping to the boiler. It is recommended to mount the circulating pump on the supply side piping, such that it pumps away from the expansion tank. Refer to the figures on the next pages.
5. A hot water boiler installed above radiation level must be equipped with a low water cut off device. A periodic inspection is necessary, per manufacturers specific instructions.
6. When connecting the cold water supply to the pressure reducing valve, make sure that a clean water supply is available. When the water supply is from a well or pump, a sand strainer should be installed at the pump.

Bypass Piping

For this section, refer to the Piping Diagrams for illustrations. (See table of contents).

NOTICE

Bypass piping may be required for applications listed below. Failure to do so may cause damage due to thermal shock and sustained condensation within the boiler and void the warranty.

This high efficiency cast iron low mass boiler must be protected from sustained operation of return water temperatures lower than 130°F (54C). Occasionally, temperatures as low as 70°F (21C) may return back to the boiler as a zone that has not been activated for some time is opened. However, most residential systems with finned-tube (aluminum-copper) baseboard radiation contain a low volume of water and will not adversely affect the boiler. Systems with finned-tube baseboard radiation typically do not require a bypass.

BOILER SYSTEM PIPING

NOTICE

The bypass piping details shown in the piping diagrams **MUST** be used for any one of the following conditions:

- A. All large water content systems, including cast iron standing radiators, cast iron baseboard, converted two-pipe steam systems, converted gravity circulation systems and other similar systems.
- B. Any system, including finned-tube baseboard, with a priority domestic hot water zone.

A $\frac{3}{4}$ inch bypass line must be installed as shown in the piping diagrams for the systems identified above.

A bypass valve cannot protect the boiler from sustained condensing operation for low temperature applications such as radiant floor heating. These types of system require active controls that prevent the return of cold return water to the boiler.

Consult your local heating specialist. In addition, refer to the Radiant Panel Association (RPA) www.radiantpanelassociation.org for piping recommendations for non-condensing boiler applications.

PIPING DIAGRAMS

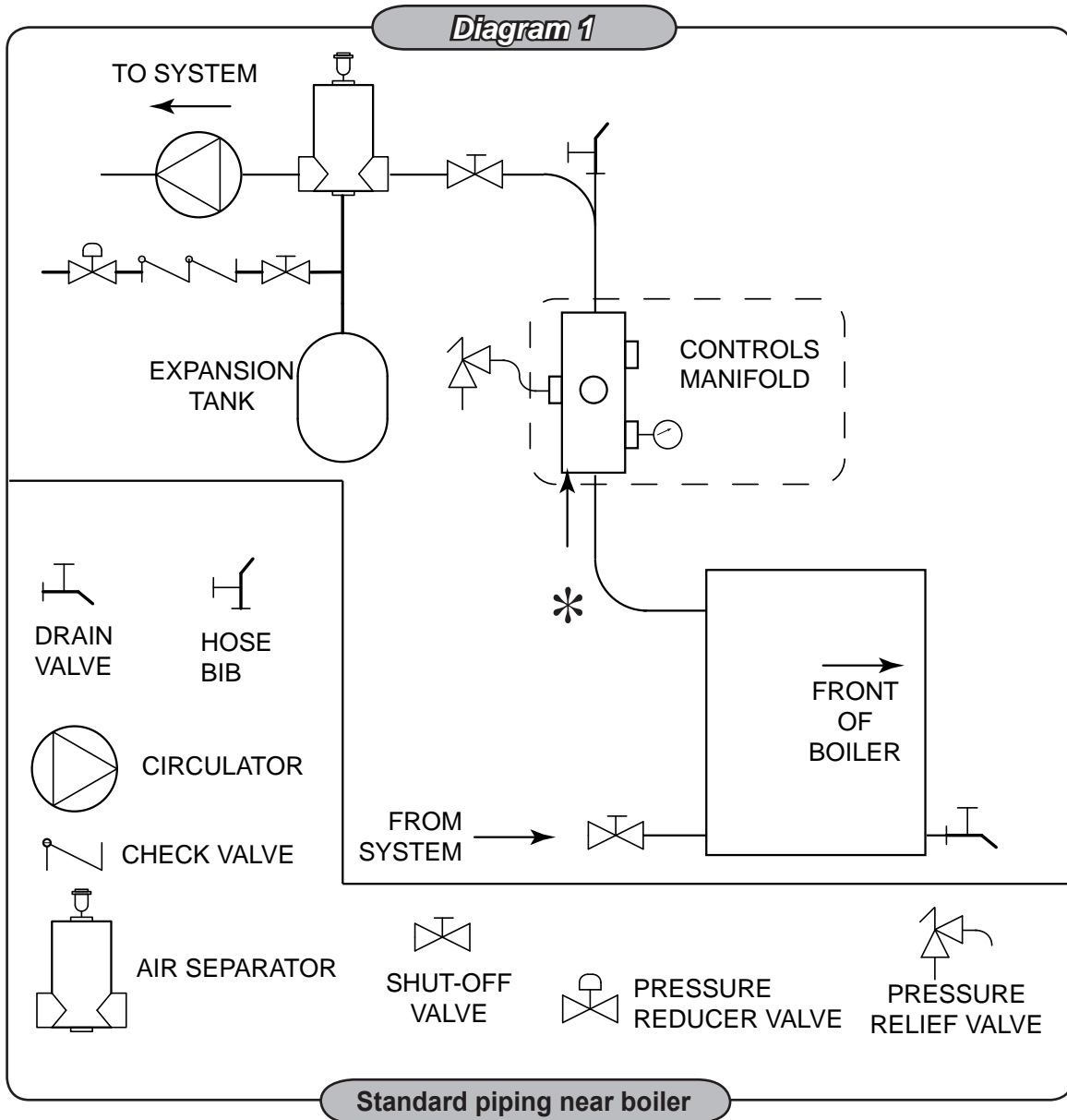

* **WARNING**
**NO VALVE MAY BE INSTALLED BETWEEN
 BOILER AND CONTROLS MANIFOLD OR
 SAFETY RELIEF VALVE.**

PIPING DIAGRAMS

Diagram 2

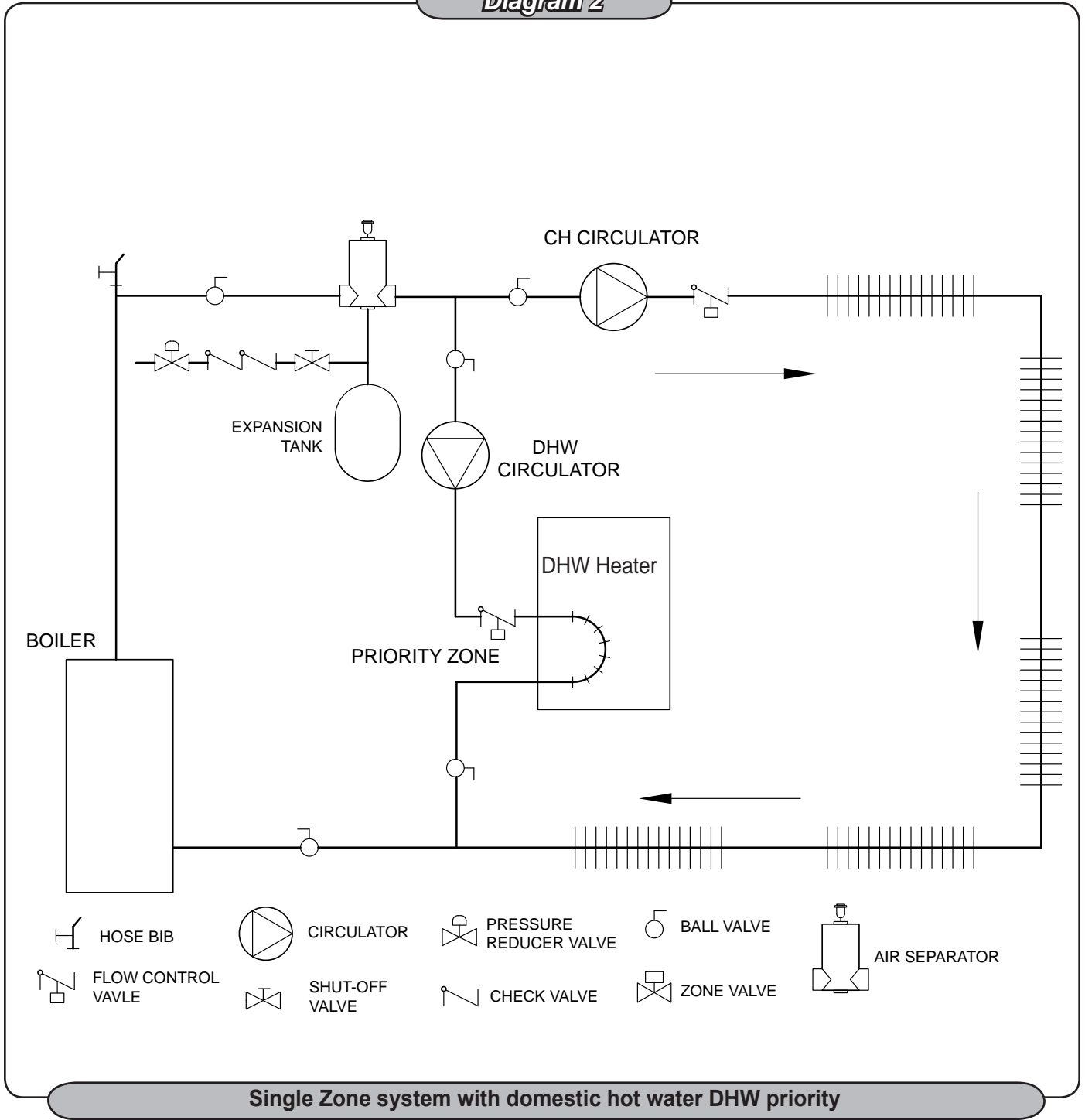

PIPING DIAGRAMS

Diagram 3

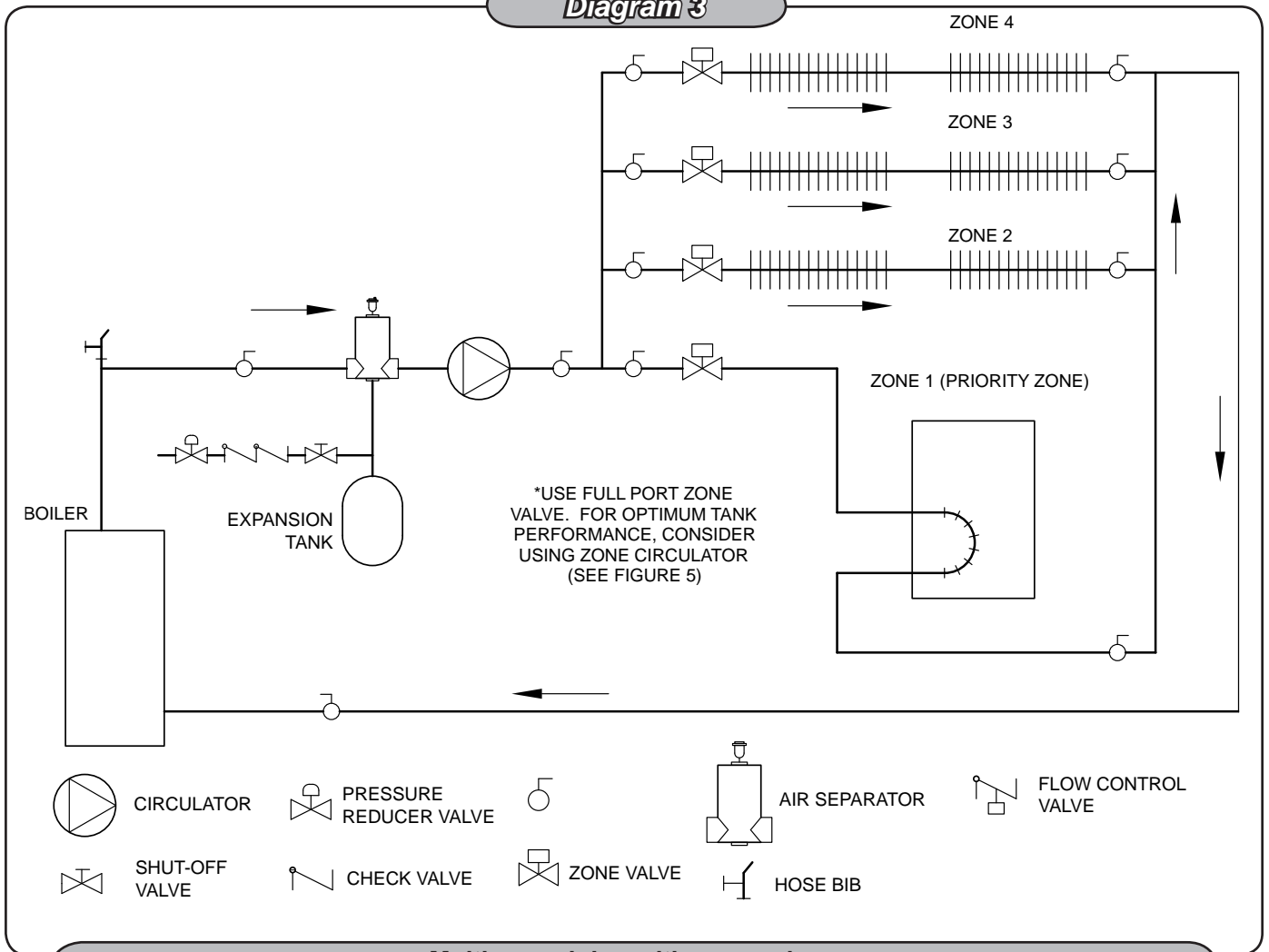

**Multizone piping with zone valves
And domestic hot water priority (with zone valve)**

PIPING DIAGRAMS

Diagram 4

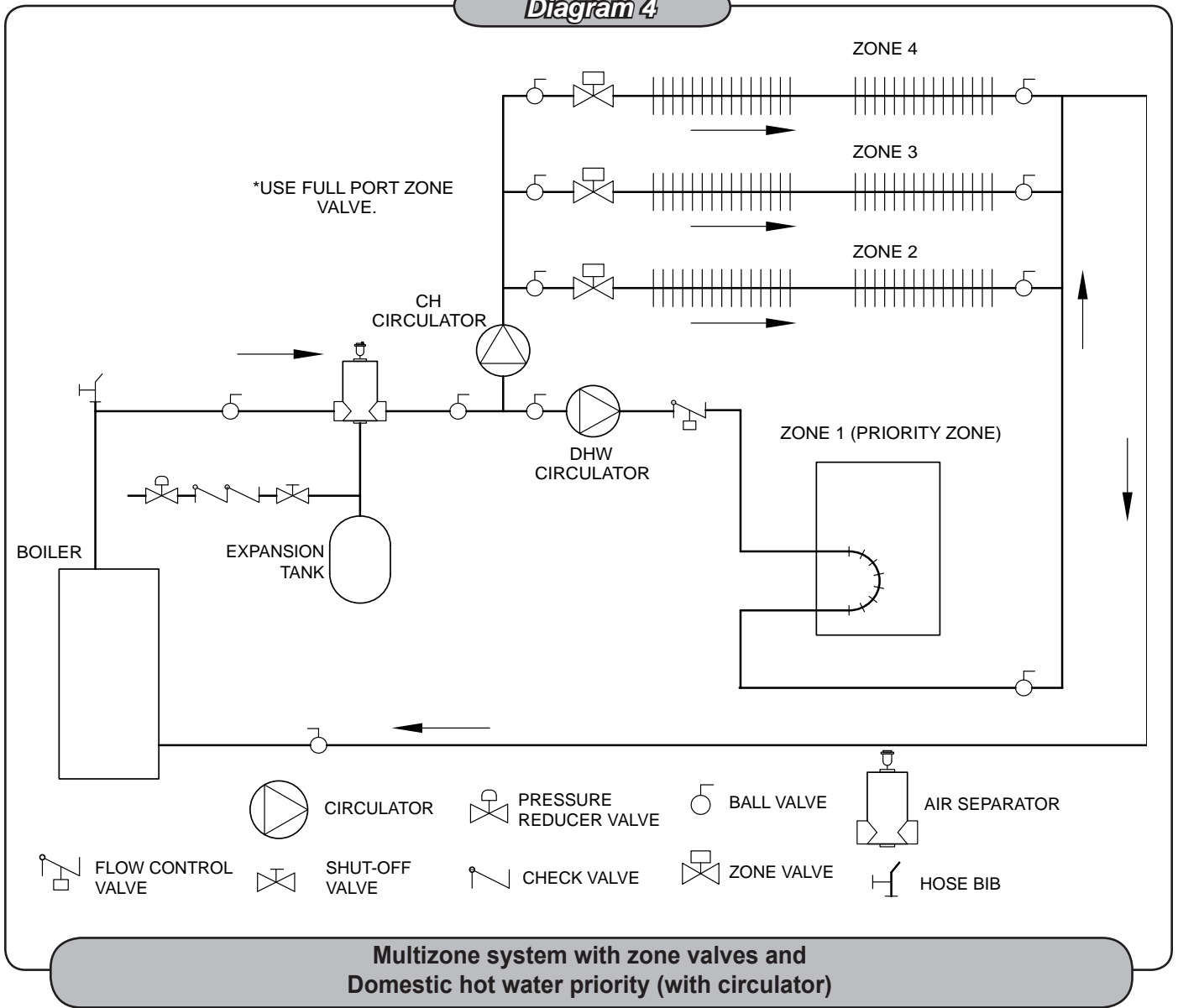

PIPING DIAGRAMS

Diagram 5

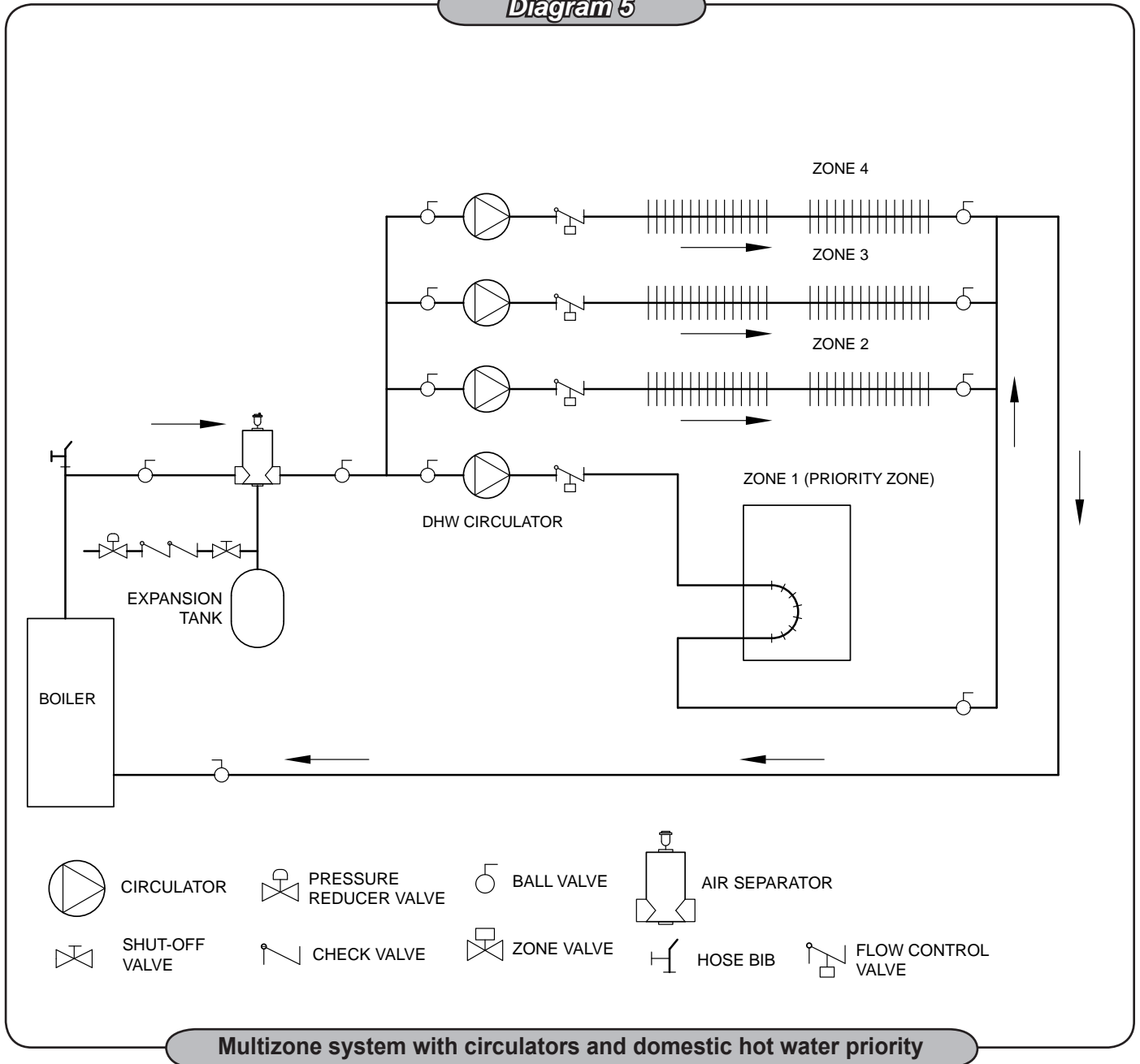

PIPING DIAGRAMS

Diagram 6

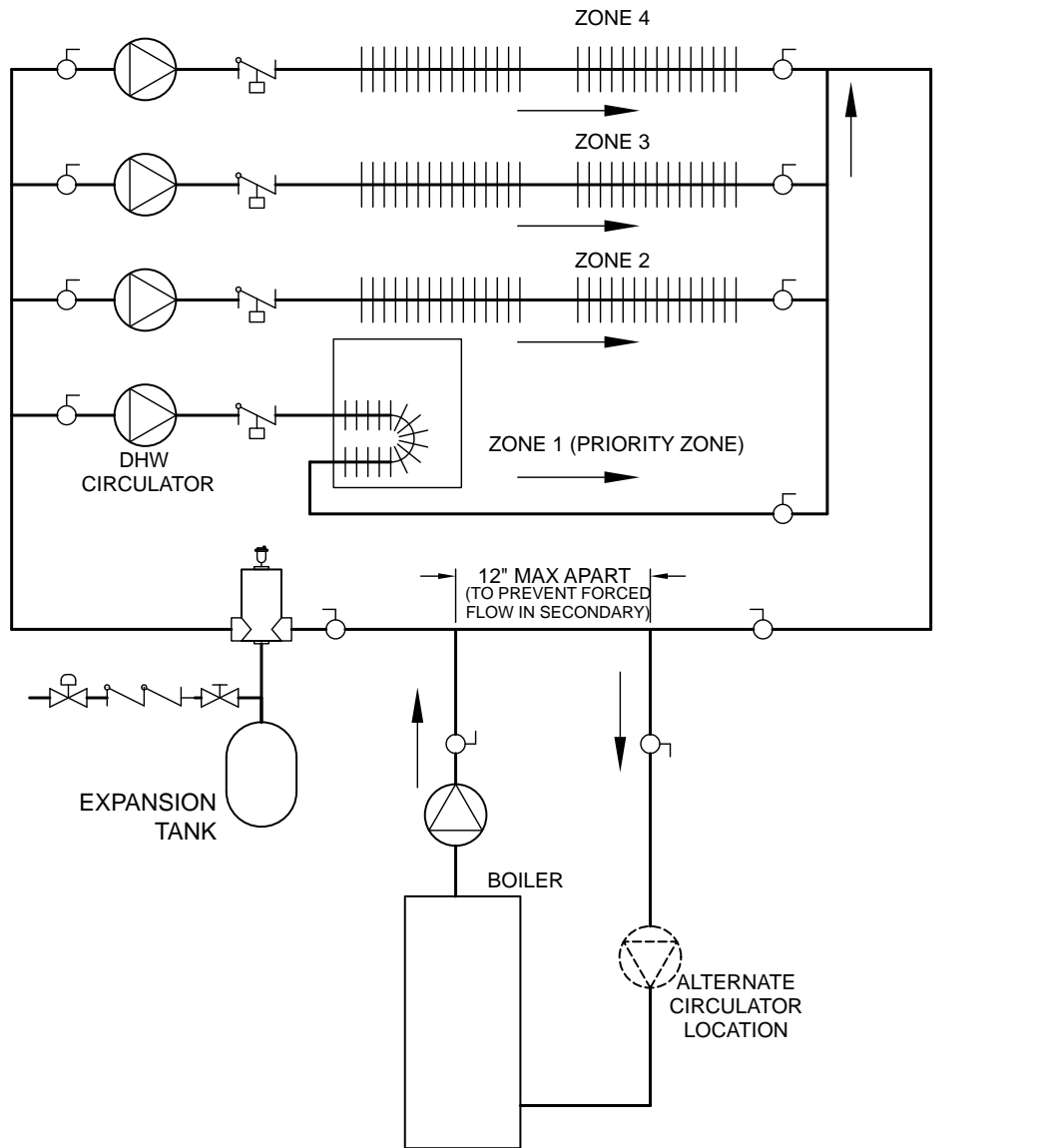

 FLOW CONTROL VALVE

 CIRCULATOR

 SHUT-OFF VALVE

 PRESSURE REDUCER VALVE

 CHECK VALVE

 BALL VALVE

 ZONE VALVE

 AIR SEPARATOR

 HOSE BIB

Primary/secondary piping with circulators and domestic hot water

PIPING DIAGRAMS

Diagram 7

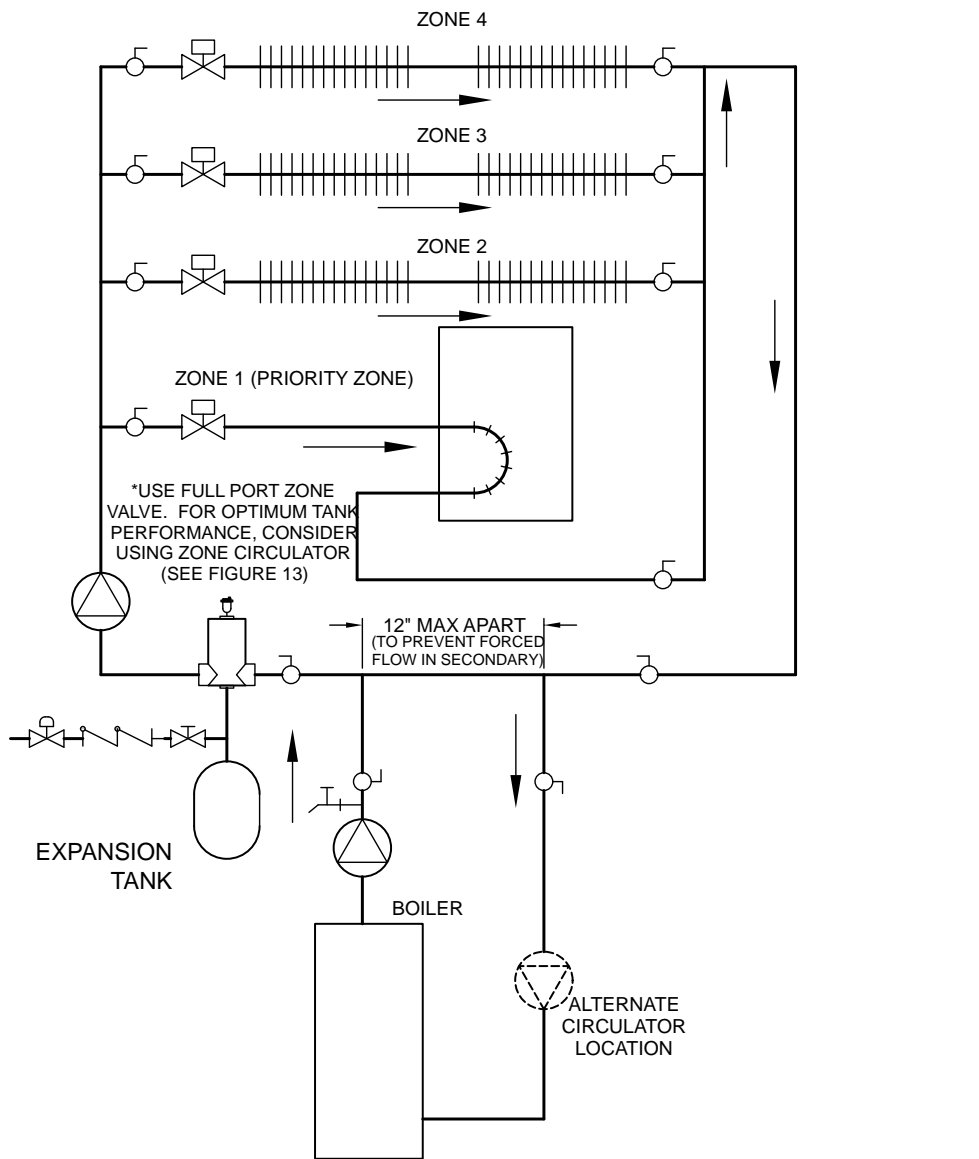

 FLOW CONTROL VALVE

 CIRCULATOR

 SHUT-OFF VALVE

 PRESSURE REDUCER VALVE

 CHECK VALVE

 BALL VALVE

 ZONE VALVE

 AIR SEPARATOR







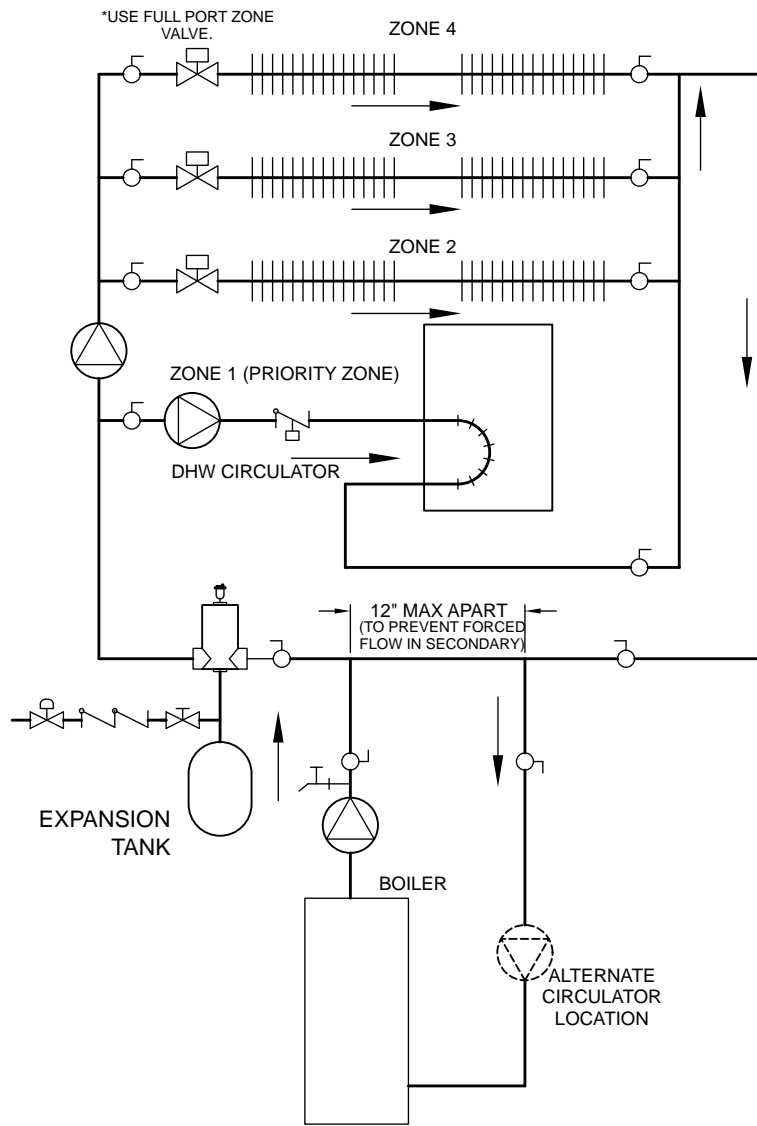

 HOSE BIB

Primary/secondary multizone system piping with Zone valves and domestic hot water (with zone valve)

PIPING DIAGRAMS

Diagram 8

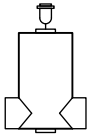

-  FLOW CONTROL VALVE
-  CIRCULATOR
-  SHUT-OFF VALVE
-  PRESSURE REDUCER VALVE
-  CHECK VALVE
-  BALL VALVE
-  ZONE VALVE
-  AIR SEPARATOR
-  HOSE BIB

**Primary/secondary piping with zone valves
And domestic hot water (with circulator)**

PIPING DIAGRAMS

Diagram 9

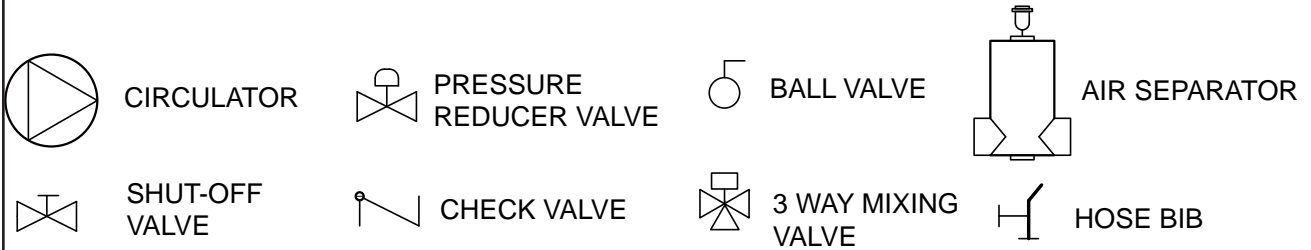
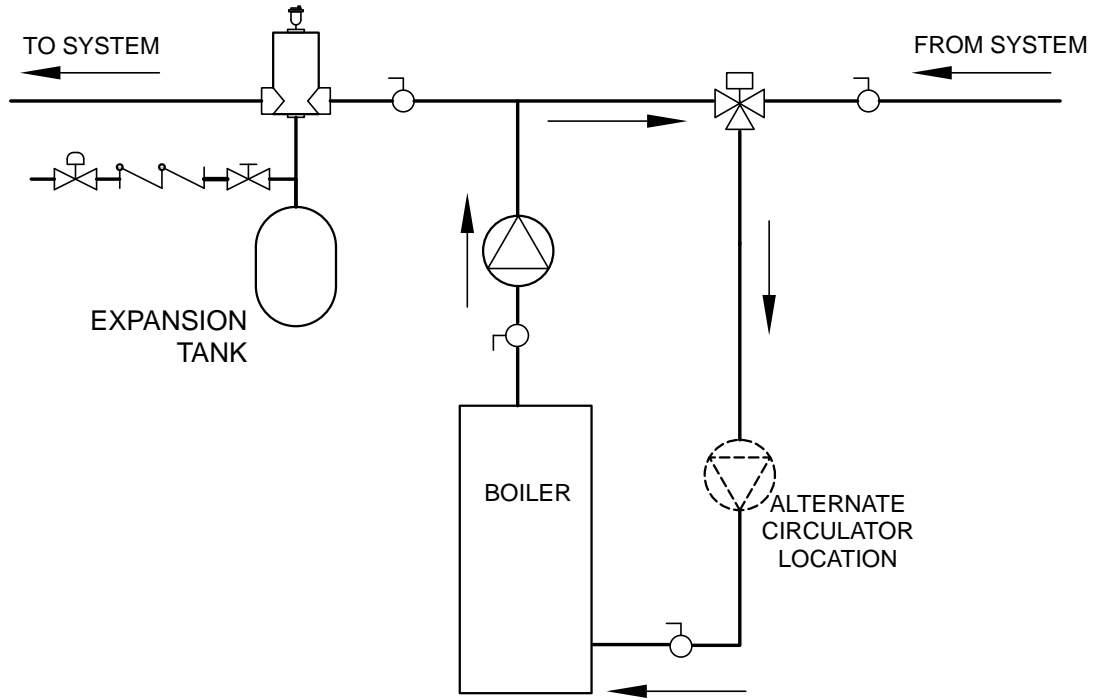

Bypass piping (automatic mixing valve)

PIPING DIAGRAMS

Diagram 10

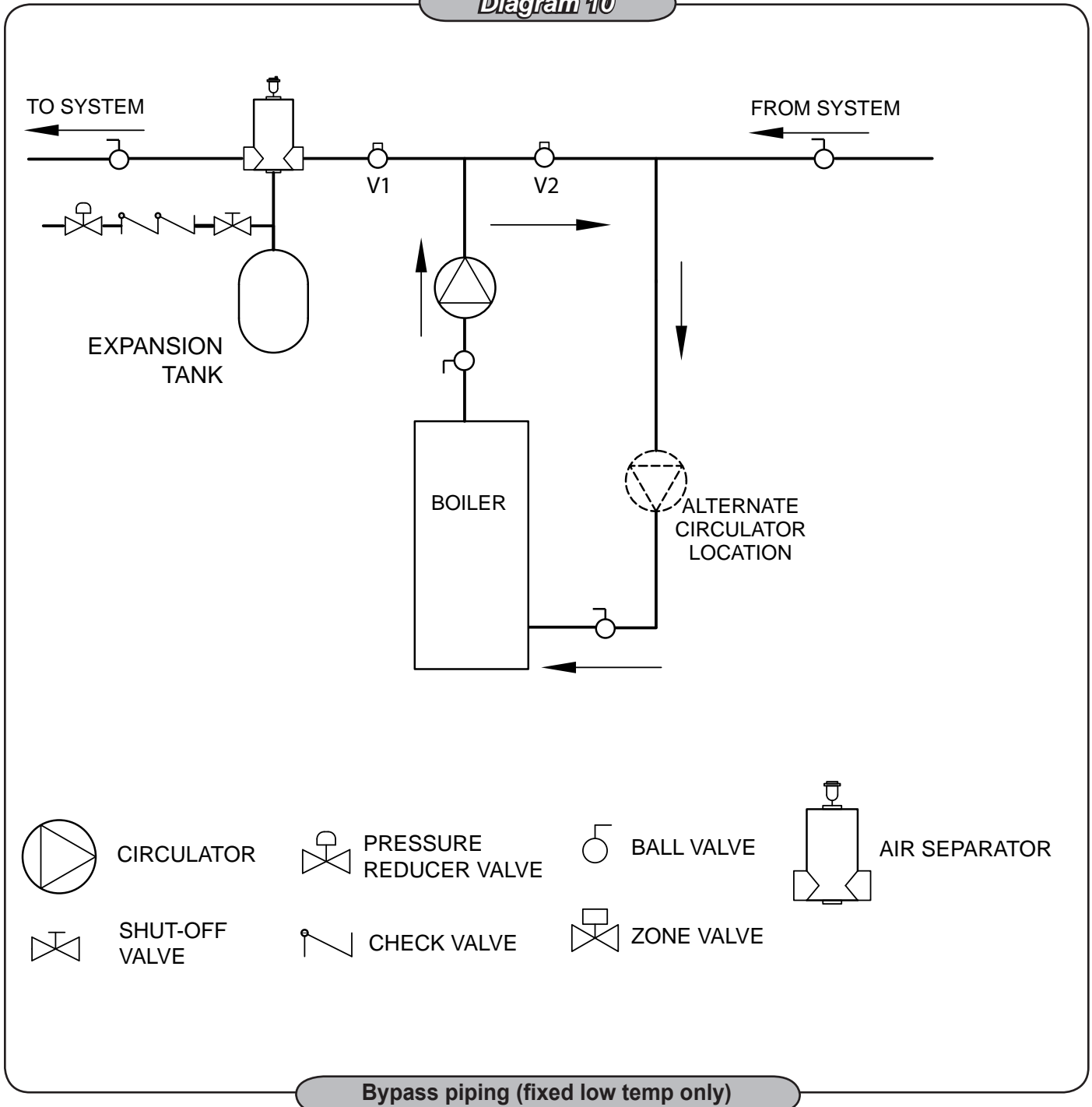

Adjust the two throttling valves to maintain at least 130°F - 140°F in the boiler return.

Diagram 11

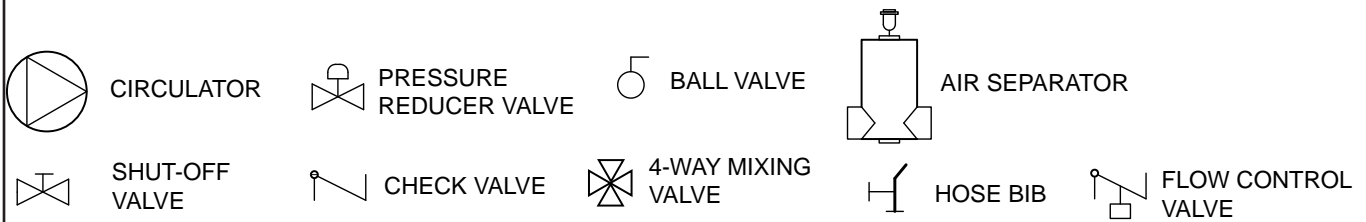
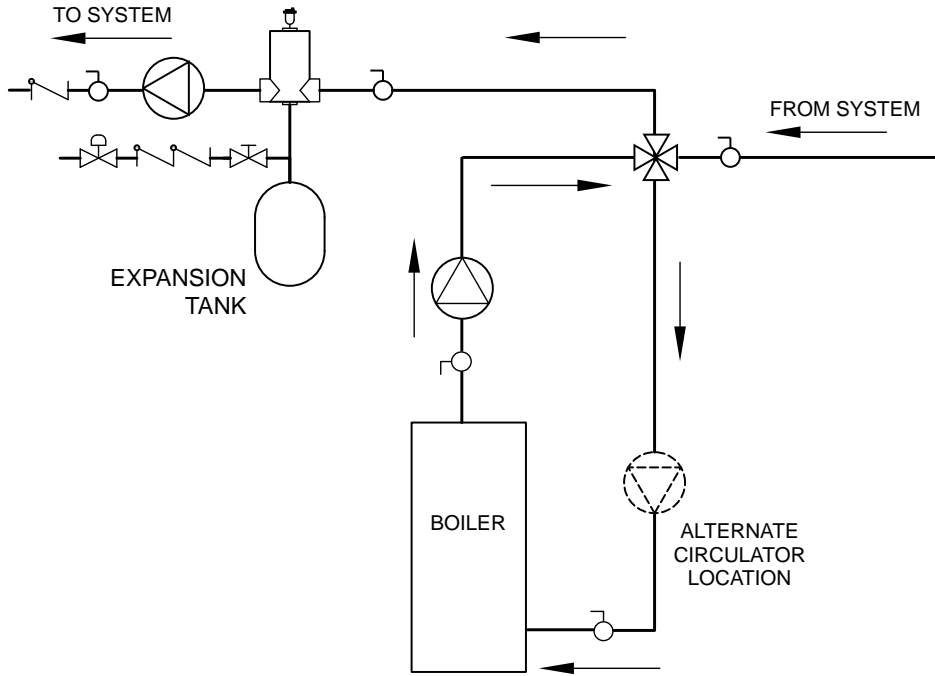

Bypass piping (4-way valve option with circulator on supply side)

Diagram 12

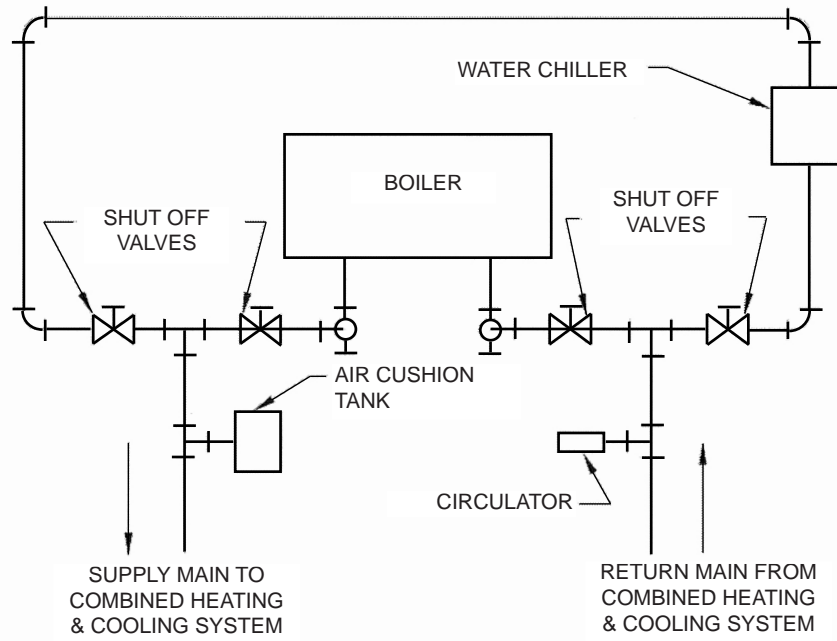

Recommended Piping for Combination Heating and Cooling (Refrigeration) System

Connect Oil Lines To Boiler

1. Use flexible oil lines so the burner swing door can be opened without disconnecting the oil supply piping.
2. A supply line fuel oil filter is required as a minimum for all firing rates but a pleated paper fuel filter is recommended for the firing rates below 1.0 gph to prevent nozzle fouling.
3. Use flared fittings only.
4. When using copper, cast iron fittings cannot be used.
5. Use of a high efficiency micron filter (Garber or equivalent) in addition to a conventional filter is highly recommended.
6. Piping used to connect the oil burner to the oil supply tank shall not be smaller than 3/8" iron pipe or 3/8" OD copper tubing. Copper tubing shall have a .032" minimum wall thickness.

WARNING

Under no circumstances can copper with sweat style connectors be used

NOTICE

Do not use compression fittings. Oil piping must be absolutely air tight or leaks or loss of prime may result. Bleed line and fuel unit completely. Refer to your local jurisdictions regarding any special considerations for fuel supply requirements. In addition, refer to NFPA 31 (U.S.) or CSA B139 (Canada)

NOTICE

Some jurisdictions require the use of a fusible shutoff valve at the tank and/or the burner. In addition, some jurisdictions require the use of a fusible electrical interlock with the burner circuit. Check your local codes for special requirements.

Figure #14

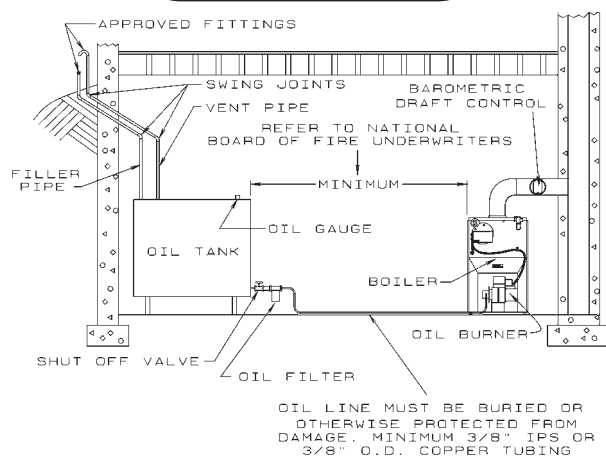

Single pipe oil line

Single Oil Pipelines

1. Standard burners are delivered as single-stage , single pipe installation (with the bypass plug removed.)
2. The single-stage fuel unit may be installed single-pipe with gravity feed or lift. Maximum allowable lift is 8 feet. See **Figure #14**.
3. Fuel Oil Line Deaerator- On many occasions a leaky oil delivery line can introduce air into the fuel oil supply system. This often creates a rough starting condition and can create a burner lockout state. In addition to fixing the leak, a fuel line deaerator can be installed to eliminate air. The single line from the fuel tank is connected to the deaerator. The burner pump must be connected to the deaerator as a two pipe system, typically requiring the installation of the bypass plug. Follow the oil pump manufacturer's recommendations for conversion to a two pipe system.

Figure #15

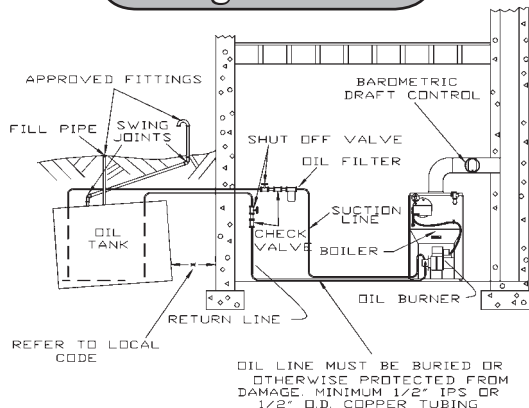

Two pipe oil lines

FUEL OIL PIPING

**TABLE 5: TWO STAGE UNITS, TWO PIPE SYSTEMS
(SEE FIGURE #15)**

LIFT "H"	Maximum Length of Tubing "R"	
	3/8" O.D. Tubing (3 GPH)	1/2" O.D. Tubing (3 GPH)
0	93 FT.	100 FT.
2	85 FT.	100 FT.
4	77 FT.	100 FT.
6	69 FT.	100 FT.
8	60 FT.	100 FT.
10	52 FT.	100 FT.
12	44 FT.	100 FT.
14	36 FT.	100 FT.
16	27 FT.	100 FT.
18	---	76 FT.

ANTIFREEZE IN THE SYSTEM

Antifreeze added to boilers must be nontoxic, and must be of a type specifically intended for use in closed hydronic heating systems. Under no circumstances should automotive antifreeze be used. Antifreeze used in any boiler may reduce capacity by 10% or more and increase fuel consumption. Refer to **Table 6 & Table 7**.

**TABLE 6:
BOILER WATER VOLUMES**

Number of Boiler Section	Total Volume (Gallons)
4	3.6
5	4.3
6	5.1
7	5.9

TABLE 7: PIPING WATER VOLUMES

PIPE SIZE	COPPER PIPE FACTOR	STEEL PIPE FACTOR
1/2"	82.5	63.5
3/4"	40.0	36.0
1"	23.3	22.2
1 1/4"	15.3	12.8
1 1/2"	10.8	9.5
2"	6.2	5.8

Divide total length of piping in feet by appropriate factor in table to determine volume in gallons.

ELECTRICAL CONNECTIONS

⚠ DANGER

Positively assure all electrical connections are not powered before attempting installation or service of electrical components or connections of the boiler to building. Lock out all electrical boxes with padlock once power is turned off.

⚠ WARNING

Failure to properly wire electrical connections to the boiler may result in serious physical harm. Electrical power may be from more than one source. Make sure all power is off before attempting any electrical work. Each boiler must be protected with a properly sized fused disconnect. Never “jump out” or make inoperative any safety or operating controls.

Figure #17

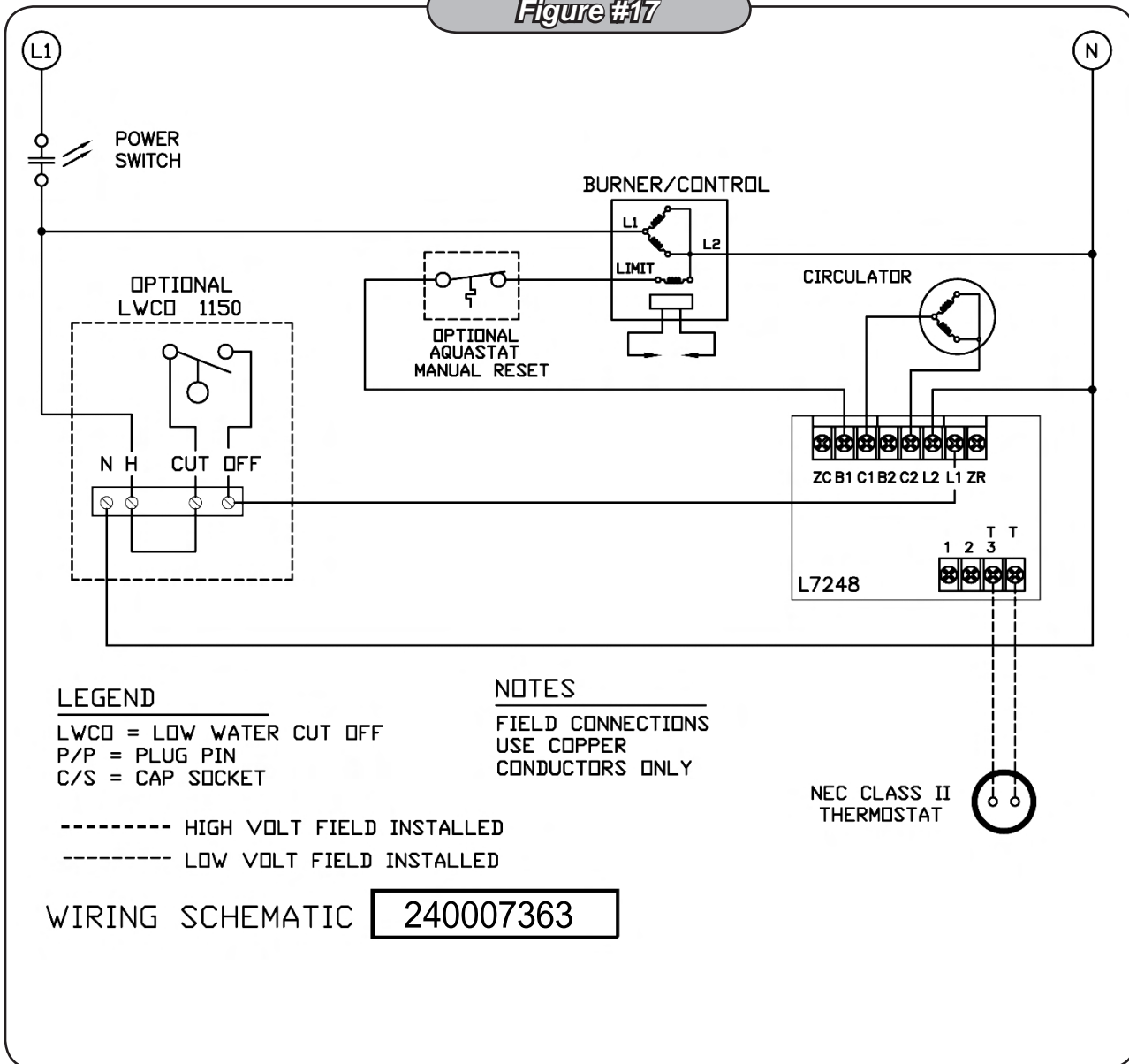

LEGEND

LWCO = LOW WATER CUT OFF
 P/P = PLUG PIN
 C/S = CAP SOCKET

----- HIGH VOLT FIELD INSTALLED
 ----- LOW VOLT FIELD INSTALLED

NOTES

FIELD CONNECTIONS
 USE COPPER
 CONDUCTORS ONLY

NEC CLASS II
 THERMOSTAT

WIRING SCHEMATIC 240007363

Figure #18

ECR WIRING DIAGRAM REVISION: A 02/06/08 pf P/N: 240007363

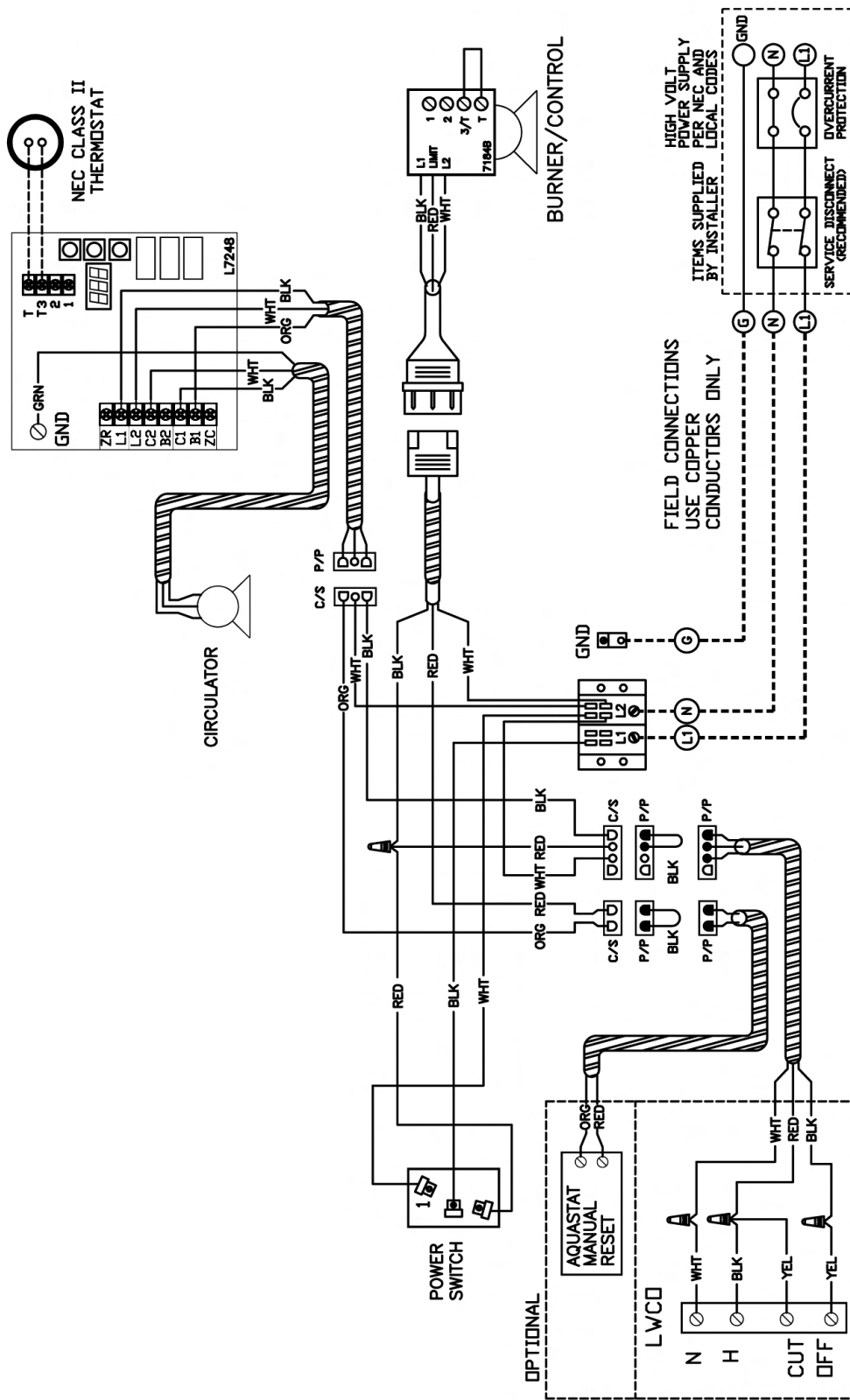

Wiring Diagram - All Models (optional equipment shown)

CHIMNEY AND CHIMNEY CONNECTIONS

For oil fired boilers with connections to vents or chimneys, vent installations shall be in accordance with applicable provisions of NFPA31 INSTALLATION OF OIL BURNING EQUIPMENT, latest revision, (U.S.) or CSA B139 (Canada) and applicable provisions of local building codes.

NOTICE

Fresh air (ventilation) is important to proper venting. Ventilation and venting are two parts of the same system. Inadequate ventilation will result in inadequate venting. Always be sure to have enough ventilation to ensure proper venting.

TABLE 8: RECOMMENDED MINIMUM CHIMNEY SIZES

FIRING RATE (gph)	CHIMNEY HEIGHT (ft)	NOMINAL CHIMNEY	ROUND LINER INSIDE	SQUARE LINER INSIDE
0.60 -1.30	15	8" x 8"	6"	6 ¾" x 6 ¾"
1.31 -1.80	15	8" x 8"	7"	6 ¾" x 6 ¾"
1.81 -2.00	20	8" x 8"	8"	6 ¾" x 6 ¾"

For elevations above 2,000 feet above sea level, add 3 feet to the chimney heights.

CHIMNEY VENTING

- Chimney venting is an important part of a safe and efficient oil fired appliance system. Requirements of NFPA31 – Standard for the Installation of Oil-Burning Equipment and NFPA 211 – Standard for Chimneys, Fireplaces, Vents, and Solid Fuel-Burning Appliances for installations in the United States and the requirements of CSA B139 – Installation Code for Oil-burning Equipment. (Installations in Canada) must be met.
- Ensure that there is sufficient draft during the entire heating season to allow for the safe evacuation of flue gasses.
- The boiler can be vented into a fireclay tile-lined masonry chimney constructed from type L vent or a factory built chimney that complies with the type HT requirements of UL103. See **Figure#20** for recommended installation.
- Chimney Inspection – Prior to the installation of any new or replacement fuel burning equipment the chimney shall be inspected by a qualified installer. The chimney shall be examined by a qualified person in accordance with the requirements of NFPA 211, Standard for Chimneys, Fireplaces, Vents, and Solid Fuel Burning Appliances or CSA B139.
 - Loose Mortar – Loose mortar could be an indication of prior history of condensing flue gases upon the inside walls of the chimney. Colder climates are more susceptible to this condition. Under no circumstances shall a chimney of this condition be used until it meets the requirements of NFPA 211 or CSA B139.
 - Unlined Chimney – Under no circumstances shall a chimney constructed of brick only be used. Only approved clay liners or listed chimney lining systems shall be used as specified in NFPA 31 or CSA B139
 - Abandoned Openings – Openings through the chimney wall that are no longer used shall be sealed in accordance to NFPA 211. Often abandoned openings are improperly sealed and usually covered by a gypsum wall covering.
 - Clean Chimney – Chimney shall be free of all loose debris.
- Install draft regulator at least 18" above breach. At least 18" of straight run up stream of regulator will ensure proper operation.
- Draft Regulator – the draft regulator supplied with the boiler must be used with this appliance. No other draft regulator shall be used. Refer to **Figure#10**.

WARNING

De-rating the appliance may cause condensation on the interior walls of the chimney and the boiler.

CHIMNEY AND CHIMNEY CONNECTIONS

VENT PIPE

1. A Vent pipe is used to connect the boiler to the chimney. The vent pipe should be kept as short as possible. The horizontal length of the vent pipe should not be greater than 10 feet.
2. Type L Vent pipe – a type L vent or other suitable material shall be used for a vent pipe if the flue temperature is less than 570° F.
3. Attach vent pipe and flue adaptor ring with three screws. Pre-drill cast iron flue collar to prevent cracking.
4. The 4,5 & 6 section boilers have a sheet metal flue collar spacer included in the accessory carton.
5. Canadian versions have a vent spill switch kit included.

DANGER

The chimney and connector shall be inspected annually for signs of debris and corrosion. Loose mortar at the base of the chimney may be a sign of condensate damage to the chimney. A chimney professional shall be contacted immediately to examine the damage and recommend a solution. Long term operation while in this condition may cause a venting failure and force flue gases into the living space. If the chimney is to be re-lined, use the recommendations in NFPA31, Appendix E or CSA B139.

DANGER

Any signs of condensate seepage at the base of the chimney shall be inspected immediately. The discoloration may be a sign of chimney damage and must be remedied immediately.

DRAFT

1. The natural draft generated through a chimney is dependent on several factors including, chimney height, temperature of flue gases, cross section area of chimney, chimney wall insulation value, dilution air and total volume of flue gases. Make sure that the boiler has been running for at least 5 minutes before measuring the draft.
2. Minimum Draft at Breech – The draft induced by a chimney must create at least a pressure of 0 (zero) inches water column (INWC) at the breach. The pressure at the breach cannot be positive since this could create a condition that allows flue gas by-products to escape from the draft regulator. Draft is to be measured up stream of the draft regulator. (See the **Burner Specifications** section at the rear of this manual for more details.)

CHIMNEY AND CHIMNEY CONNECTIONS

Figure #19

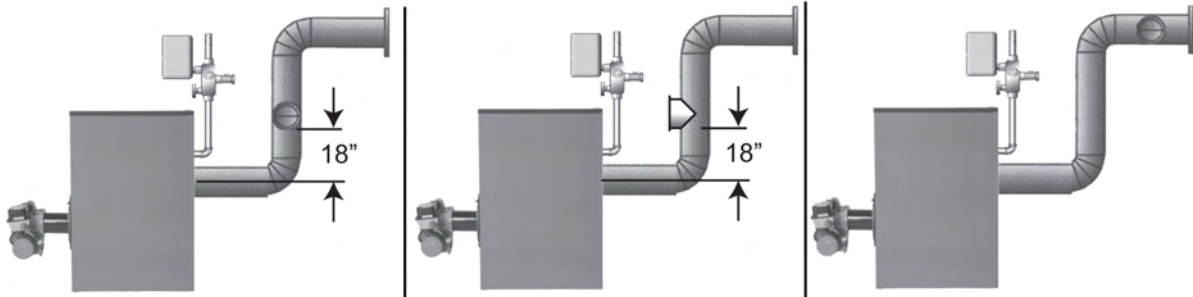

Proper draft vent locations

Figure #20

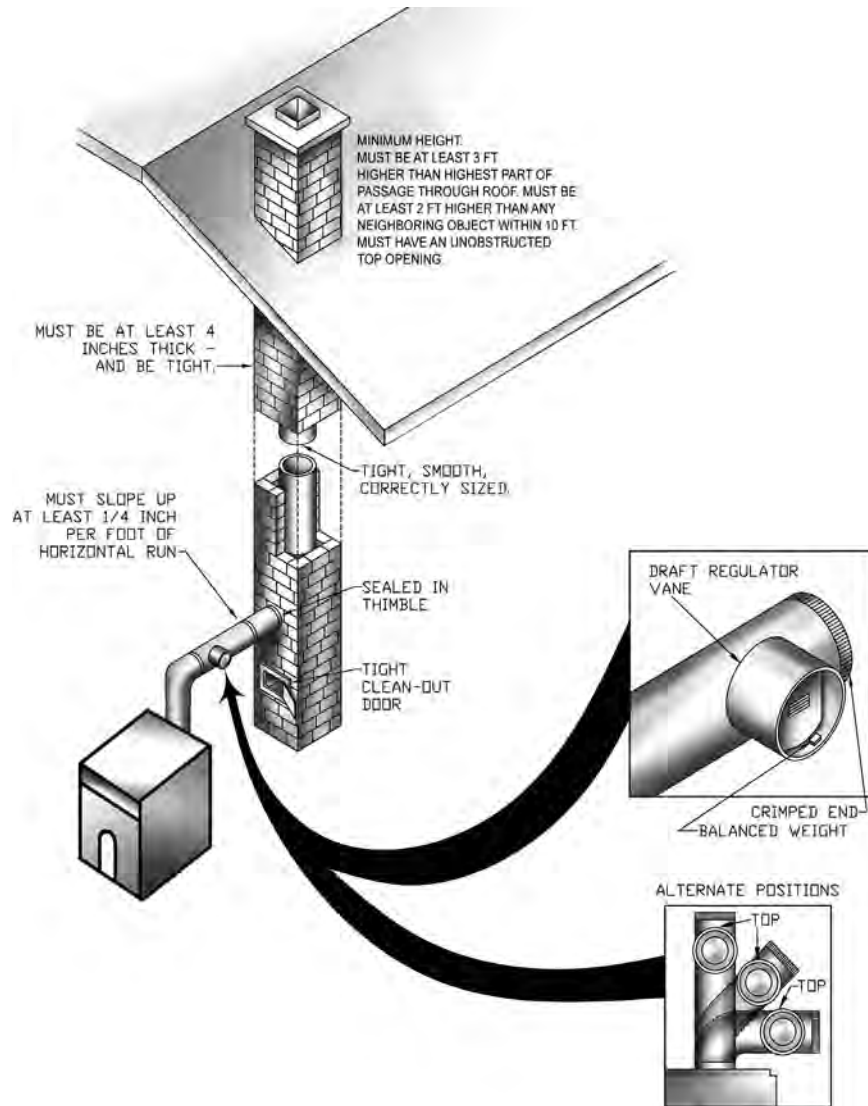

Typical Chimney Locations

CHIMNEY AND CHIMNEY CONNECTIONS

3. Overfire pressure- Measure pressure in 1/4" NPT test port. The 3-pass boilers have higher pressure drop than a single pass. **Table 8A** shows the expected pressure drop between the overfire and breech. Add together. (IE draft= -0.05 INWC breech = 0.05, total pressure drop = 0.10 INWC) See **Figure #21**.

Table 8A:

Pressure drop between overfire & breech

Sections	Baffle In	Baffle Out
4	0.03-0.05	0.03-0.05
5	0.05-0.08	0.05-0.08
6	0.09-0.16	0.09-0.16
7	N/A	0.07-0.16

STACK TEMPERATURE

- The higher the stack temperature, the greater the amount of draft that can be generated. A lower stack temperature not only reduces the amount of draft that can be created but it also increases the possibility that the flue gases could condense in the chimney connector or stack.
- NFPA 31 and CSA B139 have information to help the installer make an appropriate choice of venting materials. In some cases, a chimney may have to be lined to create sufficient draft. In other cases, the chimney may have to be lined to prevent the corrosion of a masonry chimney. Consult with a chimney specialist knowledgeable on the requirements for chimney requirements in your area.
- Baffles – The efficiency of the boiler is based on the insertion of flue baffles supplied with 4, 5 & 6 section units. The baffles are installed in the 3rd pass (two inner flueways). Refer to the **ASSEMBLING THE BOILER** section for baffle installation. Remove the baffles to increase the stack temperature.

! WARNING

Remove the baffles if there are any signs of condensation in the chimney or chimney connector. Removing baffles may not address condensation.

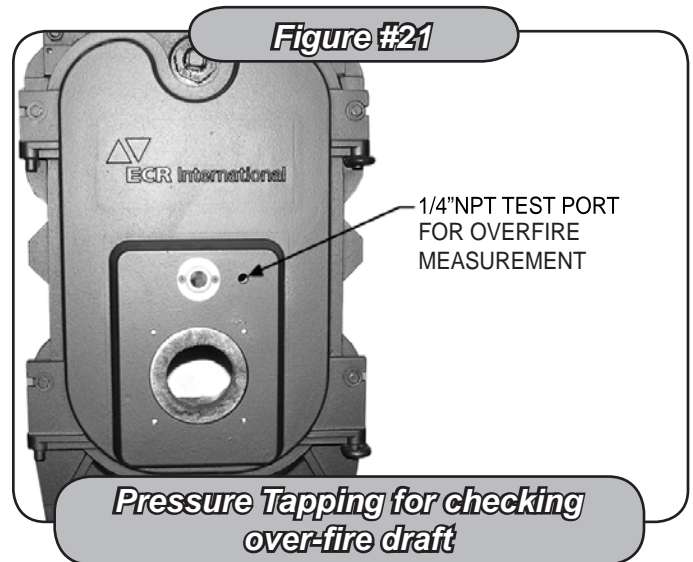

! WARNING

All boilers equipped with burner swing door have a potential hazard which can cause severe property damage, personal injury or loss of life if ignored. Before opening swing door, turn off service switch to boiler to prevent accidental firing of burner outside the combustion chamber. Be sure to tighten swing door fastener completely when service is completed. In addition, the burner power cord will have to be disconnected from the wire harness in the front jacket. Completely read, understand and follow all instructions in this manual before attempting to start up boiler.

1. ALWAYS INSPECT INSTALLATION BEFORE STARTING BURNER

- A. Verify that the venting, water piping, oil piping, and electrical system are installed properly. Refer to installation Instructions contained in this manual.
- B. Confirm all electrical, water and oil supplies are turned off at the source and that the vent is clear from obstructions.

2. FILL HEATING SYSTEM WITH WATER

NOTICE

It is important to properly remove the oil and dirt from the water system. Failure to clean the system can result in clogged air vents, circulator damage and seized zone valves.

CLEAN HEATING SYSTEM if boiler water is dirty. Refer to Maintenance and Service Instructions Section of this manual for proper cleaning instructions for water boilers. Fill entire heating system with water and vent air from system. Use the following procedure on the series loop or multi- zoned system installed as per **PIPING DIAGRAMS**, to remove air from system when filling:

- A. Close full port ball valve in boiler system piping.
- B. Isolate all zones by closing zone valves or shut-off valves in supply and return of each zone(s).
- C. Attach a hose to vertical purge valve in boiler system supply piping up steam from the full port ball valve. (NOTE – Terminate hose in five gallon bucket at as suitable floor drain or outdoor area).
- D. Starting with one zone at a time, open zone valve or shut-off valve in boiler supply and return piping.
- E. Open purge valve.
- F. Open shut-off valve in cold water supply piping located between the air scoop and expansion tank.
- G. When zone valve is completely purged of air, close zone valve or shut-off valve. Open zone valve to

the next zone to be purged. Repeat this step until all zones have been purged. At completion, open all zone valves.

- H. Close purge valve, continue filling the system until the pressure gauge reads 12 psi. Close shut- off valve in cold water supply piping.

! WARNING

The maximum operating pressure of this boiler is posted on the ASME Data Label located on the front lower leg of the boiler. Never exceed this pressure. Do not plug relief valve.

- I. Open full port valve in boiler system piping.
- J. Remove hose from purge valve.
- K. Confirm that the boiler and system have no water leaks. Jacket and insulation may be installed after the boiler is piped and leak tested.
- L. It may be necessary to clean the air vent assembly after a few days of operation.

3. CHECK CONTROLS, WIRING AND BURNER. Be sure that all connections are tight and burner is rigid, that all electrical connections have been completed and fuses installed, and that oil tank is filled and oil lines have been tested.

4. ADJUST AQUASTAT CONTROL SETTINGS. Set burner service switch turned to "ON" and room thermostat set to 10° below room temperature.

- A. On the L7248A, the overall range of the High limit is from 180°F to 220°F (82 C to 104 C). Later models may have greater range.
- B. Set the High Limit (HL) on the L7248A Aquastat Control at 180°F. This temperature setting may be varied to suit requirements of installation. Differential is fixed at 15°F.

l. Adjusting the Aquastat settings:

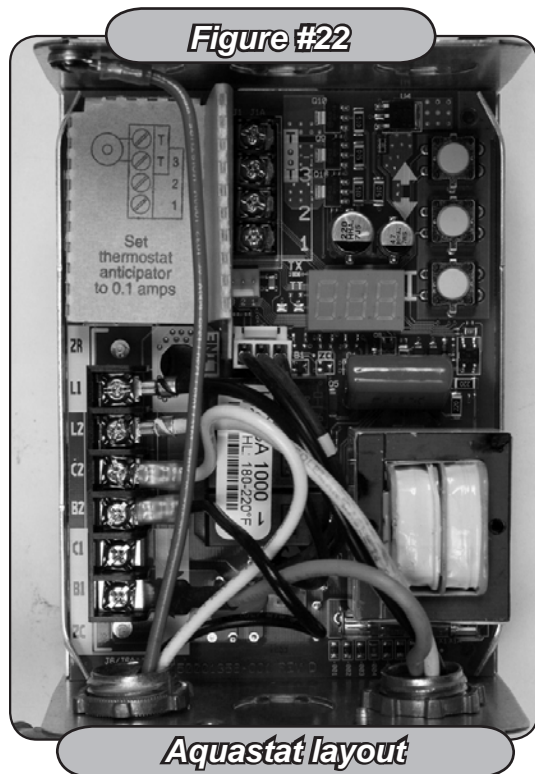

Figure #22

Aquastat layout

- To discourage unauthorized changing of Aquastat settings, a procedure to enter the adjustment mode is required. To enter the adjustment mode, press the UP, DOWN, and I buttons (see **Figure #22**) simultaneously for three (3) seconds. Press the 'I' button until the feature requiring adjustment is displayed:

High limit
°F -- °C

- Then press the UP and/or DOWN buttons to move the set point to the desired value. After 70 seconds without any button inputs, the control will automatically return to the READ mode.

II. Display:

In the RUN mode, the Aquastat will flash "bt" (boiler temp.) followed by the water temperature (i.e., 220), followed by °F or °C. To read boiler settings, press the "I" key to read the parameter of interest. For example, press I and HL (High Limit) is displayed, followed by a three-digit number, i.e., 220, followed by °F or °C. See **Table 9** for Display Readout Definitions.

After approximately 60 seconds without any key pressed, the display will enter a dim display mode. To return to the bright display mode, simply press any key.

TABLE 9: AQUASTAT DISPLAY

TEXT	DESCRIPTION	DISPLAY
bt	Boiler Temperature	b t
HL	High Limit	H L
err	Error Code	E r r
f	Degrees Fahrenheit	° F
c	Degrees Celsius	° C

Control Operating Characteristics

The L7248A can be in any three (3) operational states: Normal, High Limit and Error. The controller moves back and forth from High-Limit to Normal state as part of normal operation. The controller will enter the Error state when there is an abnormal condition. The operating states are:

- Normal: Boiler temperature has dropped below the high limit setting (minus the differential) and has not exceeded the high limit setting.
- High-Limit: Boiler temperature has risen above the high limit setting and has not dropped below the high limit setting (minus the differential).
- Error: The controller has detected an error condition (e.g., open sensor) and has shut down the burner output. The controller continues to monitor the system and automatically restarts if the error condition clears. See **Table 10**.

TABLE 10: ERROR CODES

Error Code	Cause / Action
Err1	Sensor fault; check sensor.
Err2	ECOM fault; check EnviraCOM wiring.
Err3	Hardware fault; replace control.

- The operating sequence for L7248A is described next and shown in **Table 11**.

OPERATING THE BOILER - SYSTEM START-UP

The switching action in the L7248A control has one setting, the high limit. The switching relay is controlled by the low voltage room thermostat. On a call for heat, the relay contacts close to complete the line voltage circulator circuit and also the burner circuit if the boiler water temperature is below the high limit setting. The high limit switch shuts off the burner if boiler water temperature exceeds the high limit setting. The circulator will continue to operate as long as the thermostat is calling for heat. The high limit automatically resets after the water temperature drops below the set point minus the differential.

**Table 11: L7248A Controller
Operating Sequence**

Action	System Response
Thermostat calls for heat.	Circulator starts. Boiler temperature is checked. Burner starts.
Boiler exceeds the high limit.	Burner is turned off. Burner restarts when the water temperature drops below the high limit setting minus the differential.
Thermostat is satisfied.	Circulator and burner turned off. Burner (AFG) post-purge is 15
Error Condition	If an error condition is detected, all outputs are shut down. Burner is off. Control continues to function and restarts when error is corrected. During the error check sequence, the system checks for drift in the sensor and corrosion in the connections.

1. ADJUST OIL BURNER BEFORE STARTING. (AFG)

- A. Refer to burner manufacturer's manual for details.
- B. Check burner air band, air shutter and head setting (if equipped), readjust if necessary, see **Burner Settings** section of this manual.
- C. Open all oil line valves.
- D. Attach a plastic hose to fuel pump vent fitting and provide a pan to catch the oil.

2. START OIL BURNER

- A. Open vent fitting on fuel pump. (See **Pump Priming Cycle**, 4.B.II)
- B. Press red reset button on front of oil primary cover, hold for 30 seconds and release to reset primary control, if required.

- C. Turn on burner service switch and allow burner to run until oil flows from vent fitting in a SOLID stream without air bubbles for approximately 10 seconds.
- D. Close vent fitting and burner flame should start immediately after pre-purge is completed. Pre-purge prevents burner flame until 15 seconds has elapsed after initial power is applied to burner. During pre-purge the motor and igniter will operate but the oil valve will remain closed. (Refer to Oil Primary Control Instructions.)
- E. Adjust oil pressure.
 - I. When checking a fuel unit's operating pressure, a reliable pressure gauge may be installed in either the bleeder port or the nozzle port.
 - II. Locate oil pressure adjusting screw and turn screw to obtain proper pump pressure, refer to **Burner Settings** section of this manual.
 - III. To check the cut-off pressure, deadhead a reliable pressure gauge onto the copper connector tube attached to the nozzle port. Run the burner for a short period of time. Shut the burner off. The pressure should drop and hold.
 - IV. Remove the gauge and install bleeder port and/or reconnect the nozzle port line.

3. ADJUST OIL BURNER WHILE OPERATING.

- A. Adjust Draft Regulator for a breach draft of -0.5 (preferred) to 0 inches water column after chimney has reached operating temperature and while burner is running. (At least five minutes) See **Burner Settings** section of this manual for details.
- B. Readjust the air band on burner while the breach draft is -0.5 to 0 inches water column (WC). Use a smoke tester and adjust air for minimum smoke (not to exceed a trace) with a minimum of excess air. Make final check using suitable instrumentation to obtain a CO₂ of 11.5 to 13%. These settings will assure a safe and efficient operating condition. If the flame appears stringy instead of solid fire, try another nozzle of the same type. Flame should be solid and compact. After all adjustments are made, recheck for a draft in the breach. See **Burner Settings** section of this manual.
- C. Re-adjust the head setting only if necessary.
- D. Turn off burner and remove pressure gauge. Install gauge port/bleeder plug and tighten. Start burner again.

OPERATING THE BOILER - SYSTEM START-UP

⚠ WARNING

Do not loosen or remove any oil line fittings while burner is in operation.

- E. **FLAME FAILURE:** The boiler controls operate the burner automatically. If for unknown reasons the burner ceases to fire and the reset button on the primary control has tripped, the burner has experienced ignition failure.

⚠ WARNING

Do not attempt to start the burner when oil has accumulated in the combustion chamber or when the unit is full of vapor, or is hot.

⚠ WARNING

The operation of all boiler controls must be checked, before installation of the boiler is completed.

4. TEST CONTROLS (R7184P)

- A. Check thermostat operation. Raise and lower thermostat setting as required to start and stop burner.
- B. Verify primary control features using procedures outlined in instructions furnished with control or instructions as follows:
 - I. The R7184P (Beckett HW) is a microprocessor-based control. The indicator light provides diagnostic information for lockout, recycling and patented Cad Cell status. There is a manual reset button to exit the Lockout Mode and enter the idle Mode.
 - II. **Pump Priming Cycle:** To facilitate purging air from the oil lines and filters, the R7184 can be placed in a purge routine by pressing and releasing the reset button during the safety check, delayed valve-on, ignition or carry-over periods.
 - III. **Limited Recycle:** This feature limits the number of recycle trials (for each call for heat) to a maximum of three trials. If the flame is lost three times and does not successfully satisfy a call for heat, the R7184 locks out.
 - IV. **Limited Reset (Restricted Mode):** In order to limit the accumulation of unburned oil in the combustion area, the control can only be reset three times. The reset count returns to zero each time a call is successfully completed.
 - V. To reset from Restricted Mode: Press and hold the reset button for 30 seconds. When the LED flashes twice, the device has reset.
 - VI. T-T Jumper: All models have pre-installed T-T jumper. Do not remove jumper.
 - VII. Diagnostic LED: The indicator light on oil primary control R7184P provides lockout, recycle and cad cell indications as follows:
 - Flashing 1/2 second on, 1/2 second off: system is locked out or in Restricted Mode.
 - Flashing 2 seconds on, 2 seconds off: control is in Recycle Mode.
 - On: cad cell is sensing flame.
 - Off: cad cell is not sensing flame.
 - VIII. Cad Cell Resistance Check: For proper operation it is important that the cad cell resistance is below 1600 ohms. During a normal call for heat, once the control has entered the Run Mode, press and release the reset button. Indicator light will flash 1 to 4 flashes. See Table below for equivalent cad cell resistance.

TABLE 12: CAD CELL Resistance When Sensing Flame

Flashes	Resistance in ohms
1	Less than 400
2	More than 400, less than 800
3	More than 800, less than 1600
4	More than 1600, less than 5000

⚠ CAUTION

Due to the potential hazard of line voltage, only a trained, experienced service technician should perform the following safety checks. This control contains no field serviceable parts. Do not attempt to take it apart. Replace entire control if operation is not as described.

5. CHECK OIL PRIMARY CONTROLS.

A. PRELIMINARY STEPS

- I. Check wiring connections and power supply.
- II. Make sure power is on to the controls.
- III. Make sure limit control is closed.
- IV. Check contacts between igniter and the electrodes.
- V. Check the oil pump pressure.
- VI. Check the piping to the oil tank.
- VII. Check the oil nozzle, oil supply, and oil filter.

B. CHECK SAFETY FEATURES - SAFE START

- I. Place a jumper across cad cell terminals.
- II. Follow procedure to turn on burner. Burner must not start, indicator light turns on and control remains in idle Mode.
- III. Remove jumper.

C. SIMULATE IGNITION OR FLAME FAILURE:

- I. Follow procedure to turn on burner.
- II. Close hand valve in oil supply line.
- III. Failure occurs, device enters Recycle Mode. Indicator light flashes 2 seconds on, 2 seconds off.
- IV. Device tries to restart system after approximately 60 seconds.
- V. After third Recycle Mode trial, safety switch locks out within safety switch timing indicated on label and control enters Restricted Mode. Indicator light flashes 1/2 second on, 1/2 Second off. Ignition and motor stop and oil valves closes.
- VI. To reset from Restricted Mode: Press and hold the reset button for 30 seconds. When the LED flashes twice, the device has reset.

D. Cad Cell Check : see *Figure #23*.

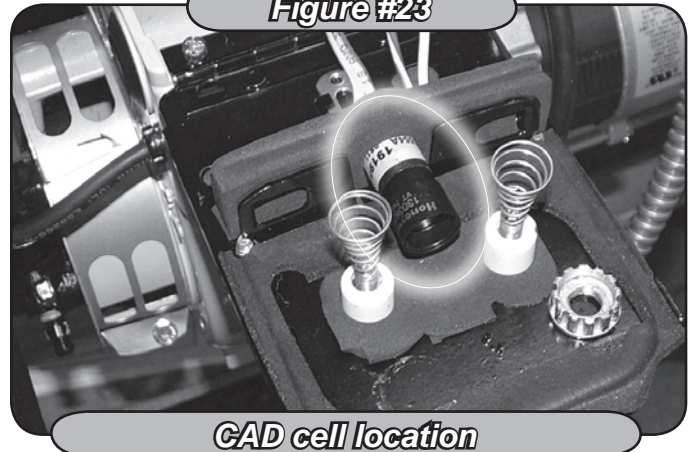

- I. Perform cad cell resistance check as outlined in control feature. If resistance is below 1600 OHMS and burner runs beyond safety cut-out time, cad cell is good.
- II. If safety switch shuts down burner and resistance is above 1600 OHMS, turn on power to the boiler. Access cad cell under igniter, clean face of cad cell and see that cell is securely in socket. Check gasket around perimeter of igniter lid for proper seal. If gasket is missing or damaged, replace gasket. Room light can affect cad cell resistance. Reset safety switch.
- III. Turn off power. If burner starts and runs beyond safety switch cut-off time, cell is good. If not, install new cell.
- E. Power Failure Check: After flame is established, turn the power off to the control / burner. The burner should shut down safely. When power is restored, a normal ignition sequence should be started.

6. CHECK HIGH TEMPERATURE LIMIT CONTROL-

Jumper Thermostat Terminals. Allow burner to operate until shut down by limit. Installation is not considered complete until this check has been made.

⚠ WARNING

Jumper must be removed after this check!

7. IF CONTROLS DO NOT MEET REQUIREMENTS replace control and repeat checkout procedures.



CAUTION

Do not run boiler unattended until the following procedure is completed.

8. NOZZLES AND ELECTRODES: Use the proper size, spray angle, and spray pattern nozzle. Refer to the recommended nozzle selection charts at the end of this manual. To install a nozzle, remove the nozzle line electrode assembly, if necessary remove the retention ring assembly, and then install and tighten the nozzle. Be careful not to damage the electrode insulators or bend the electrode tips. After installing the nozzle, reassemble the nozzle line electrode assembly and set the electrode tip spacing. The electrode tip spacing may need to be set prior to reassembling the nozzle line electrode assembly. Refer to the figures on the following pages for setting the electrode tip spacing on Beckett.

9. FINAL BURNER ADJUSTMENTS: Final burner adjustments must be made using combustion test instruments. Initial settings for the burner are shown at the back of this manual.

- A. Set the burner accordingly. Check the draft breech to verify that it is between 0.00" WC and -0.05" WC, or otherwise adjust the draft to -0.05" WC (or less than zero.) After operating 10 minutes to warm up the boiler, use the combustion test equipment to take a smoke reading in the flue pipe between the boiler and the draft regulator. The smoke reading should be zero to a trace (Shell Bacharach Scale). At times a new boiler requires more than 10 minutes to burn clean due to the oil film on the new heat exchanger. If the smoke reading is zero, gradually close the burner's air adjustment to obtain a smoke reading showing a trace smoke reading. Once the smoke reading is a trace, measure the CO₂ and as an insurance margin increase the air to sufficiently reduce the CO₂ by 1/2% to 1%.
- B. If a clean fire cannot be obtained, it will be necessary to verify the burner head alignment. If the fire continues to be smoky, replace the nozzle.
- C. Once the burner is completely adjusted, the burner should be started and stopped several times to assure good operation with no fluttering or rumbling.

Verify that there are no oil leaks and then record the nozzle size, oil pressure, combustion readings, and air settings on a tag or label that can be attached to the burner or, boiler.

10. CHECK OPTIONAL LOW WATER CUT OFF CONTROL AND OPTIONAL MANUAL RESET TEMPERATURE LIMIT. These are optional kits. Please see instructions for installation, startup check out and maintenance. *Figure #23A* shows where these optional kits are plugged into the control panel.

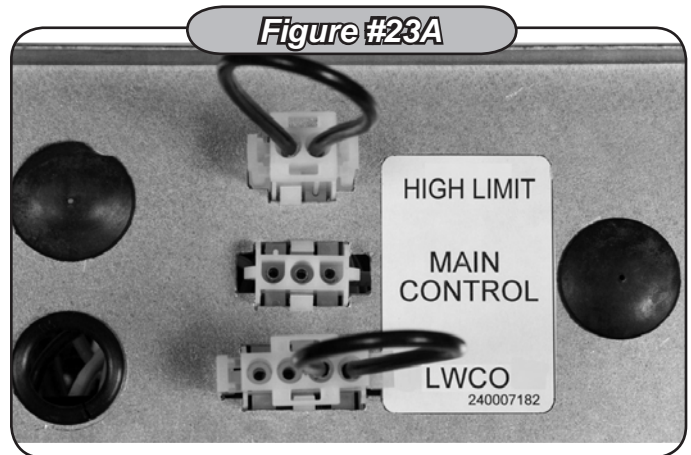

11. CHECK THERMOSTAT OPERATION: The thermostat location has an important effect on the operation of the boiler system. Be sure to follow the instructions included with your thermostat. Typically, the thermostat is located about five feet above the floor on an inside wall. The thermostat should be located to sense average room temperature, so avoid the following:

TABLE 13: THERMOSTAT LOCATIONS TO AVOID

DEAD SPOTS	HOT SPOTS	COLD SPOTS
Behind doors	Concealed pipes	Concealed pipes or ducts
	Fireplace	
	TV sets	Stairwell drafts
Corners & alcoves	Radios	Door drafts
	Lamps	Unheated room on other side of wall
	Direct sunlight	
	Kitchens	

Make certain: once the room temperature reaches the selected temperature setting, the thermostat should turn the boiler's burner off, and once the room temperature falls a few degrees the boiler starts operating again.

This page intentionally left blank.

OIL BURNER, NOZZLE, & AIR SETTINGS

TABLE 14: BURNER SETTINGS

BURNER	BOILER SECTIONS	HEAD	STATIC PLATE	INSERT DEPTH	FIRING RATE (GPH)	PUMP PRESSURE (PSIG)	NOZZLE RATE	AIR BAND	AIR SHUTTER	"Z" OR AIR HEAD SETTING
BECKETT AFG	4	L2	3.375 U	2.675	0.75	140	0.65 X 60B	0	7	N/A
	5	L2	3.375 U	2.675	1	140	0.85 X 60B	2	10	N/A
	6	V1	2.75 M	2.675	1.30	140	1.10 X 60AS	1	10	0
	7	V1	2.75 M	2.675	1.65	175	1.25 X 45 AS	4	10	2
Timings (fixed)		R7184P1080		See next page for nozzle brands.						
Pre-purge		15 seconds								
Post-Purge		15 seconds								

NOTE: All burners use an insertion depth of 2 5/8" and fired at a breech draft of -0.05 to 0.00 inches W.C. The burner settings provided are intended for initial start up only. Final adjustment must be made using combustion test instruments.

Figure #24

Beckett AFG Burner Electrode Adjustments Variable (V1, L1) Heads

Boiler Model	Dimension "N" (Electrode to nozzle)	Dimension "H" (Head to nozzle)
All	1/16"	7/32" - 9/32"

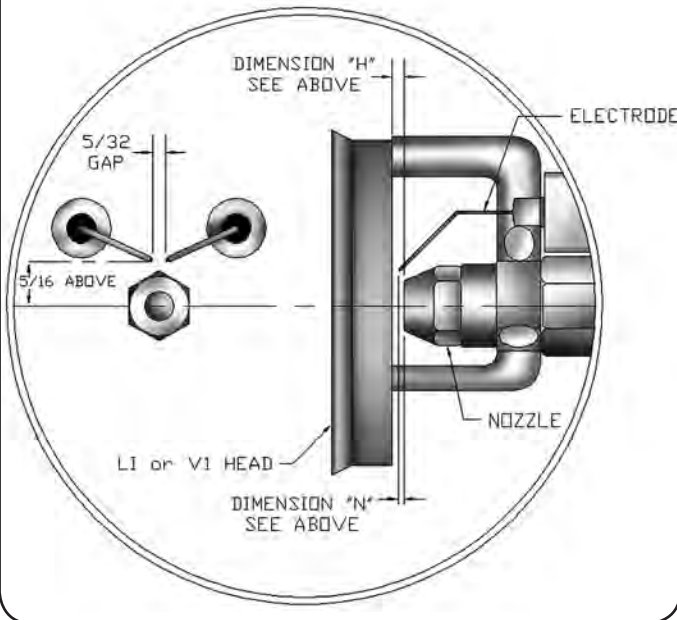
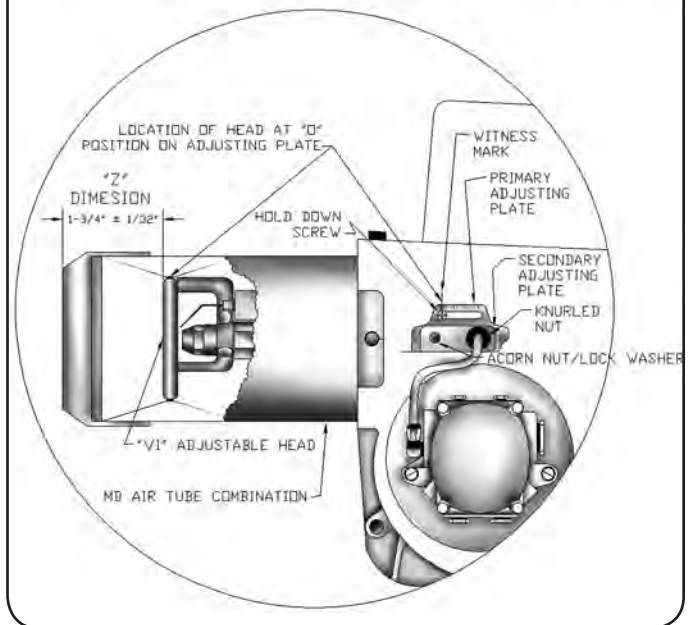

Figure #25

Beckett AFG Variable (V1) Head Adjustments and Settings

Dimension "Z" For L1, V1 Heads

1 3/4"



OIL BURNER, NOZZLE & AIR SETTINGS

TABLE 15: BURNER SPECIFICATION FOR TRI-FIRE OIL FIRED WATER BOILER

For use only with the following oil burner part numbers:

BURNER MAKE	BOILER MODEL	BURNER PART #	PUMP PRESSURE	DELAVAN	HAGO	DANFOSS
Beckett AFG	75	240007232	140 PSIG	0.65 X 60 B	0.65 X 60 B	N/A
	100	240007233	140 PSIG	0.85 X 60 B	0.85 X 60 B	N/A
	130	240007234	140 PSIG	N/A	1.10 x 60 B	1.10 X 60 AS
	165	240007235	175 PSIG	N/A	N/A	1.25 X 45 AS

Certified for use with "L" type vent.

ANNUALLY: To assure trouble free operation, it is recommended that the flue passages, combustion chamber area (target wall, fire door insulation) burner adjustment, operation of the controls, and boiler seals (fire door gasket or silicone seal, cast iron sectional seals, flue collector) be checked once each year by a competent Service Technician. **Before the start of each heating season** (or whenever the system has been shut down for extended periods of time) recheck the whole system for water, oil, and vent piping leaks. Replace or patch any leaks or seals that are faulty.

VENT PIPE: Visually inspect the entire venting system once a month for any signs of leakage, deterioration, or soot build up. If the vent pipe shows any signs of leaking or deterioration, replace it immediately. If it shows any signs of soot build up, clean the vent pipe and have the burner settings and combustion checked by a competent professional.

RELIEF VALVE: This valve should open automatically when the system pressure exceeds the pressure rating (usually 30 psi) of the relief valve. Should the valve ever fail to open under this condition, shut down the system. Drain the system until system pressure is reduced below the relief valve pressure rating. Then contact a competent Service Technician to replace the valve and inspect the heating system and determine the cause, as this problem may indicate an equipment malfunction. The relief valve should be tested bimonthly during the heating season. Prior to testing, make certain a discharge pipe is properly connected to the valve outlet and arranged so as to contain and safely dispose of boiler discharge. Hold the trip lever fully open for at least five seconds in order to flush free any sediment that may lodge on the valve seat. Then permit the valve to snap shut. Refer to the valve manufacturer's instructions packaged with the valve for more details.

CONVENTIONAL EXPANSION TANK: As noted in the **"EQUIPMENT AND ACCESSORIES"** section.

DIAPHRAGM EXPANSION TANK: As noted in the **"EQUIPMENT AND ACCESSORIES"** section.

WATER SYSTEM: If the system is to remain out of service during freezing weather, always drain it completely (water left in the system will freeze and crack the pipes and/or boiler).

OIL BURNER MAINTENANCE: For the Beckett AFG, the following preventative maintenance items should be performed annually, preferably prior to the heating season.

1. **Fuel Filter** This should be replaced so as to prevent contaminated fuel from reaching the nozzle. A partially blocked fuel filter can cause premature failure of the fuel pump.
2. **Fuel Pump Unit** Replace pump screen and clean pump unit to maintain fuel delivery to the nozzle.
3. **Ignition Electrodes** Clean and adjust as per manufacturer's recommendations, so as to maintain reliable ignition of oil.
4. **Nozzle** Replace so as to maintain safe and reliable combustion efficiency. Always replace with the exact nozzle as required in the charts in the back of this manual.
5. **Fan and Blower Housing** These must be kept clean, free of dirt, lint and oil so as to maintain the proper amount of air the fuel requires to burn.
6. **Check the burner settings and adjust as needed.**

NOTE: *If any component parts must be replaced, always use parts recommended by the burner manufacturer.*

MAINTENANCE OF OPTIONAL LOW WATER CUT OFF

DANGER

Assure that the boiler is at zero pressure before removing the relief valve or any probe. Open the safety valve to relieve all internal pressure prior to proceeding. Safety valve discharge piping must be piped such that the potential for burns is eliminated.

WARNING

Probe type low water cut-off devices require annual inspection and maintenance.

Although these devices are solid state in their operation, the probe is exposed to possible contamination in the boiler water and subject to fouling.



DANGER

Do not install valve between boiler and controls manifold. This would isolate safety and controls from the boiler. A shut off valve may be installed after the manifold to facilitate LWCO probe removal.

It is important to physically remove the probe from the LWCO tapping annually and inspect that probe for accumulation of scale or sediment. Follow these steps to inspect, clean and / or replace the probe:

1. Turn off electric service to the boiler controls.
2. Drain boiler water to a level below the tapping for the probe.
3. Remove the low water cut-off control from the probe.
4. Unscrew the probe from the LWCO tapping.
5. Inspect that portion of the probe that is exposed to the water for a scale or sediment buildup.
6. Light deposits may be removed by wiping the probe with a damp cloth. Wiping the probe with a cloth soaked in vinegar will remove more tenacious lime deposits.
7. Clean the pipe threads of the probe to remove old, hardened pipe dope and other foreign matter.
8. Apply a moderate amount of good quality pipe dope to the pipe threads on the probe, leaving the two end threads bare. **Do not use PTFE (Teflon) tape.**
9. Screw the probe into the LWCO tapping.
10. Mount the low water cut-off control on the probe.
11. Reconnect the control to probe wiring.
12. Fill the system with water and purge.
13. Add boiler water treatment compound as needed.
14. Restore electric service to the boiler.
15. Fire burner to bring the water in the boiler to a boil to drive off free oxygen.
16. **WARNING – BEFORE RETURNING BOILER TO SERVICE:** Follow the low water cut-off check out procedure in the **Boiler Start-Up** section.

BOILER AND SYSTEM CLEANING INSTRUCTIONS FOR TROUBLE FREE OPERATION

1. In a hot water heating system, the boiler and entire system (other than the expansion tank) must be full of water for satisfactory operation. Water should be added to the system until the boiler pressure gauge registers 12 psi. To insure that the system is full, water should come out of all air vents when opened.
2. **Boiling Out of Boiler and System.** The oil and grease which accumulate in a new hot water boiler can be washed out in the following manner:
 - A. Ideally, shut off valves have been installed between the boiler return manifold and the rest of the system, to minimize the amount of system draining.
 - B. Drain the boiler to a level below the relief valve tapping.
 - C. Remove relief valve using extreme care to avoid damaging it.
 - D. Add an appropriate amount of recommended boil out compound.
 - E. Replace relief valve.
 - F. Fill the entire system with water and purge.
 - G. Start firing the boiler.
 - H. Circulate the water through the entire system.
 - I. Vent the system, including the radiation.
 - J. Allow boiler water to reach operating temperature, if possible.
 - K. Continue to circulate the water for a few hours.
 - L. Stop firing the boiler.
 - M. Drain the system in a manner and to a location that hot water can be discharged with safety.
 - N. Remove plugs from all available returns and wash the water side of the boiler as thoroughly as possible, using a high-pressure water stream.
 - O. Refill the system with fresh water.
3. Add Appropriate Boiler water treatment compounds as recommended by your qualified water treatment company.
4. **Testing the pH / Alkalinity** After boiler and system have been cleaned and refilled as previously described, test the pH of the water in the system. This can easily be done with a pH test kit. The pH should be higher than 7 but lower than 11. Add appropriate water treatment chemicals, if necessary, to bring the pH within the specified range. With this lower level of protection, care must be exercised to eliminate all of the free oxygen in the system.
5. Boiler is now ready to be put into service.

MAINTENANCE

C) FREQUENT WATER ADDITION

Although unusual for a water boiler, frequent water additions are a sign of a leaky system. Excessive amounts of make up water supplied to the boiler can significantly shorten the life of the boiler. The amount of water varies with the contamination level of the water. Repair the leak and consult with your water treatment specialist for recommendations.

D) ATTENTION TO BOILER WHILE NOT IN OPERATION

1. Always keep the manual fuel supply valve shut off if the burner is shut down for an extended period of time.
2. To recondition the heating system in the fall season after a prolonged shut down, follow the instructions outlined in **System Start Up**.

NOTICE

If Boiler is not used during winter time, it must be fully drained to prevent freeze damage.

WARNING

This boiler contains controls which may cause the boiler to shut down and not restart without service. If damage due to frozen pipes is a possibility, the heating system should not be left unattended in cold weather; or appropriate safeguards and alarms should be installed on the heating system to prevent damage if the boiler is inoperative.

NOTICE

IMPORTANT OPERATING AND MAINTENANCE REQUIREMENTS:

Keep your boiler and the area around it clean. Never burn refuse or any material other than the specified fuel in your boiler. Have your boiler checked each year by a qualified technician.

OIL BOILER / BURNER CLEANING INSTRUCTIONS

WARNING

All boiler cleaning must be completed with burner service switch turned off. Boilers equipped with burner swing door have a potential hazard which can cause severe property damage, personal injury or loss of life if ignored. Before opening swing door, turn off service switch to boiler to prevent accidental firing of burner outside the combustion chamber. Disconnect the burner plug. Be sure to tighten swing door fastener completely and in a manner that will not strip the threads when service is completed.

1. Clean the flueways. (See *Figure #20*).
 - A. Shut off power to the burner.
 - B. For access to the combustion chamber remove the bolts. If boiler is equipped with flexible fuel line(s), swing door open.
 - C. Remove the vent connector.
 - D. Remove the liners & baffles (if equipped) from the flue passages. The baffles are installed in the 3rd pass (two inner flue ways.)
 - E. Clean the 3rd Pass – Insert a 2" Dia. x 42" long wire or fiber bristle brush into each of the two 3rd passes. Using long strokes, push the brush all the way through the boiler until the brush has exited the smoke box opening. Pull the brush all the way forward until it has exited the front of the boiler. Continue this operation for the entire height of the flue way until clean. Repeat the operation for the other 3rd pass flue way.

OIL BOILER / BURNER CLEANING INSTRUCTIONS

- F. Clean the 2nd Pass – Insert a wire or fiber bristle brush into each of the two 2nd passes. Using long strokes, push the brush all the way through the boiler until the brush hits the back wall of the reversing chamber. Pull the brush all the way forward until it has exited the front of the boiler. Continue this operation for the entire height of the flue way until clean. Repeat the operation for the other 2nd pass flue way.
 - G. Clean passage from combustion chamber to 2nd pass.
 - H. Vacuum the loose debris in the bottom of the combustion chamber and smoke box.
2. Clean the combustion chamber and baffles. Use a wire or fiber bristle brush to clean the surfaces of the combustion chamber and baffles. Vacuum all of the loose debris in the bottom of the combustion chamber.
3. After cleaning: Vacuum all remaining debris as necessary. Inspect burner swing door insulation, and rope gasket for signs of damage. If damaged, replace as needed.
4. Re-assemble the boiler.
- A. Insert the liner and baffles (if equipped) into the correct flue way. The baffles are installed in the 3rd pass. (Two inner flue ways)
 - B. Inspect the chimney and clean if necessary.
 - C. Clean and re-attach the vent connector onto the rear of the boiler with three screws.
- D. Tighten swing door hardware to provide adequate seal to rope gasket around perimeter of door. Use an alternating tightening method from non-hinged side to hinged side cap screws to pull door tight equally.

NOTICE

When securing burner swing door make sure door is drawn-in equally on both sides. Do not overtighten the door bolts. The rope gasket will provide sufficient seal when the door is snugged into place.

CAUTION

Do not start the burner unless the burner swing door and vent connector are secured in place.

WARNING

The boiler must be connected to an approved chimney in good condition. Serious property damage could result if the boiler is connected to a dirty or inadequate chimney. The interior of the chimney flue must be inspected and cleaned before the start of the heating season and should be inspected periodically throughout the heating season for any obstructions. A clean and unobstructed chimney flue is necessary to allow noxious fumes that could cause injury or loss of life to vent safely and will contribute toward maintaining the boiler's efficiency.

OIL BOILER / BURNER CLEANING INSTRUCTIONS

Figure #26

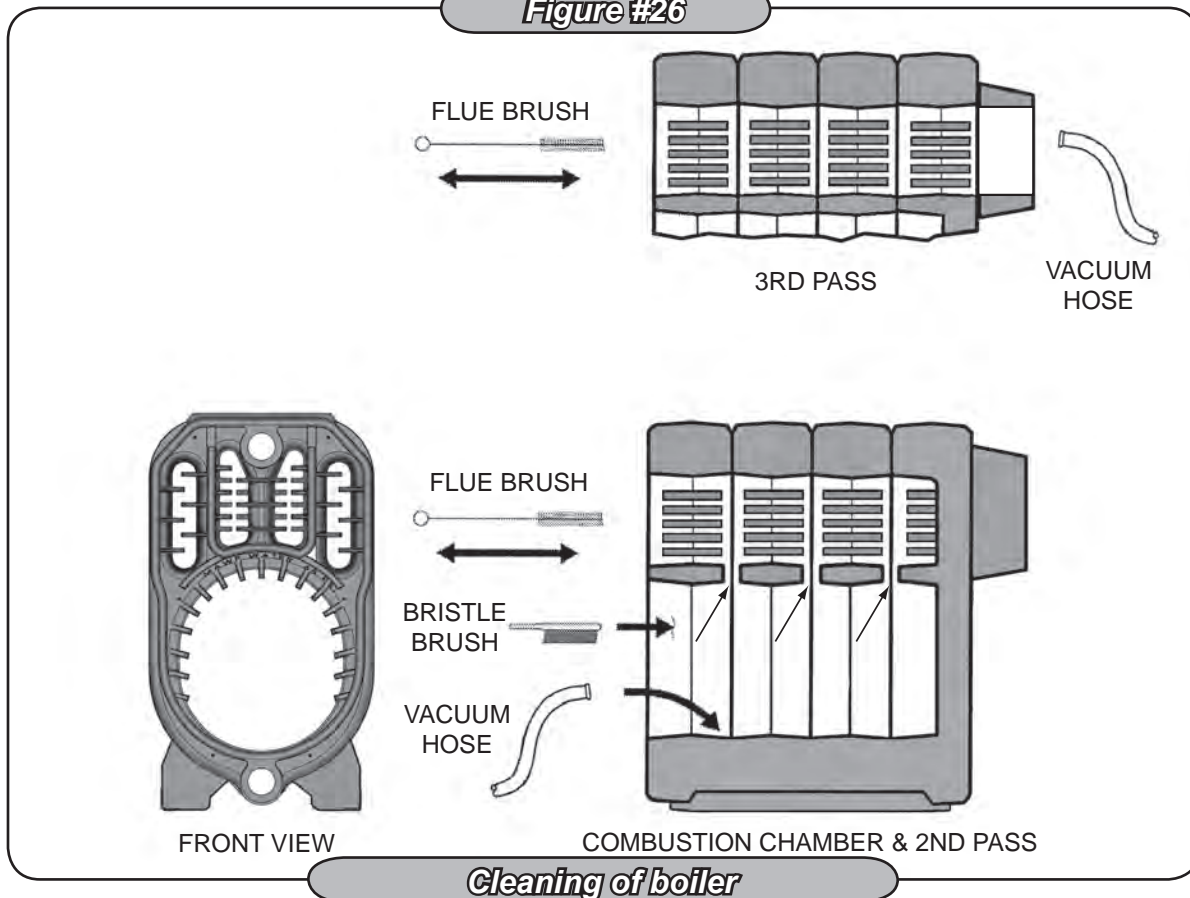

OIL BURNER CLEANING

These are general instructions for cleaning an oil burner. For specifics, consult the burner manufacturer's instructions.

⚠ DANGER

Make sure all electrical power to the boiler burner and the fuel supply to the burner are turned off.

NOTICE

Replace the oil nozzle with the exact same size and type recommended for use on this boiler. See label on side of boiler.

TROUBLESHOOTING

1. COMBUSTION

- A. Nozzles- Not all manufacturers' nozzles perform the same. **Table 15** in the **Burner Settings** section shows the nozzles that passed rigorous testing in our laboratory.
- B. Fuel leaks - Any fuel leak between the pump and the nozzle will be detrimental to good combustion results. Look for wet surfaces in the air tube, under the ignitor, and around the air inlet. Any such leaks should be repaired as they may cause erratic burning of the fuel and in the extreme case may become a fire hazard.
- C. Dirt - A fuel filter is required to prevent clogging the nozzle or nozzle strainer and produce a poor spray pattern from the nozzle.
- D. Water - Water in the fuel in large amounts will stall the fuel pump. Water in the fuel in smaller amounts will cause excessive wear on the pump, but more importantly water doesn't burn. It chills the flame and causes smoke and unburned fuel to pass out of the combustion chamber and clog the flue ways of the boiler.
- E. Cold Oil - If the oil temperature approaching the fuel pump is 40°F or cooler, poor combustion or delayed ignition may result. An outside fuel tank that is above grade or has fuel lines in a shallow bury may be the cause.
- F. High Altitude Installation - Air openings must be increased at higher altitudes. Use combustion analyzer and set to 11.5% for an initial setting.
- G. Start up noise - Late ignition is the cause of start up noises. If it occurs recheck for electrode settings, flame shape, air or water in the fuel lines.
- H. Shut-down noise - Post Purge timed 15 seconds should eliminate shut-down noise.

2. OIL PRIMARY CONTROL

- A. Burner (control) will not come on.
 - I. No power to control.
 - II. Control is in lockout or restricted mode. Press reset button for 30 seconds to exit lockout. If control has recycled three times within the same call for heat, it will enter into restricted mode. To reset from restricted mode, refer to page 41 for more details.
 - III. CAD Cell seeing light.
 - IV. CAD assembly defective.

- B. Burner (control) will light, then shut down after a short time, then restart after one (1) minute.
 - I. CAD cell is defective.
 - II. Air leaking into oil line causing flame out.
 - III. Defective nozzle causing flame to be erratic.
 - IV. Excessive airflow or draft causing flame to leave burner head.
 - V. Excessive back pressure causing erratic flame.
- C. Control locks out after trial for Ignition. (TFI)
 - I. No oil to burner.
 - II. Shortened electrodes
 - III. Clogged nozzles.
 - IV. Airflow too high.
 - V. Ignitor module defective.
 - VI. CAD cell defective.
 - VII. Oil valve stuck open or closed.

NOTICE

To isolate fuel problems: disconnect the fuel system and fire out of an auxiliary container of clean, fresh, warm #2 fuel oil from another source. If the burner runs successfully when drawing out the container then the problem is in the fuel or fuel lines.

NOTICE

If flame is not established within 15 seconds of oil valve actuation (known as Trial For Ignition or TFI) lockout will occur. Lockout is indicated by a steady on red LED located on the oil primary control.

NOTICE

Lockout without retries will occur if the flame is lost three times during one call for heat. This is indicated by a steady on red and amber LED'S

TROUBLESHOOTING

You may avoid inconvenience and service calls by checking these points before you call for service:

IF YOUR SYSTEM IS NOT HEATING OR NOT GIVING ENOUGH HEAT . . .	
<i>POSSIBLE CAUSE</i>	<i>WHAT TO DO</i>
Thermostat is not set correctly	Reset thermostat
Burner is not operating properly	Contact your service technician.
No electric power to boiler	Check over-current protection. Check to be sure electric power supply circuit is "ON". There may be as many as 3 safety shut-off switches installed. Look for a red plate which may be on the service switch.
Controls out of adjustment	Reset according to instructions.
Circulating pump not running	Check over-current protection. Check relay operation. Check power to circulator.
Poor electrical contact	Check all control terminals and wire joints.
Chimney flue is blocked	Have the chimney professionally cleaned.
RELIEF VALVE LEAKING . . .	
<i>POSSIBLE CAUSE</i>	<i>WHAT TO DO</i>
Corrosion and/or deposits on seat.	Open valve manually. Allow water to run and clear valve seat.
Water logged expansion tank	Drain tank, follow instructions to provide air buffer.
<i>HAVE YOUR SERVICE TECHNICIAN CHECK ANY PROBLEM YOU ARE UNABLE TO CORRECT.</i>	

SERVICE RECORD

Company Address & Phone #																													
Company Name & Tech Initials																													
Service Performed																													
Date																													

For technical assistance with this product call toll free 1-800-325-5479
ECR International
PO Box 4729
Utica, NY 13504-4729
www.ecrinternational.com